

ANEXO I: MODELOS CONCEPTUALES

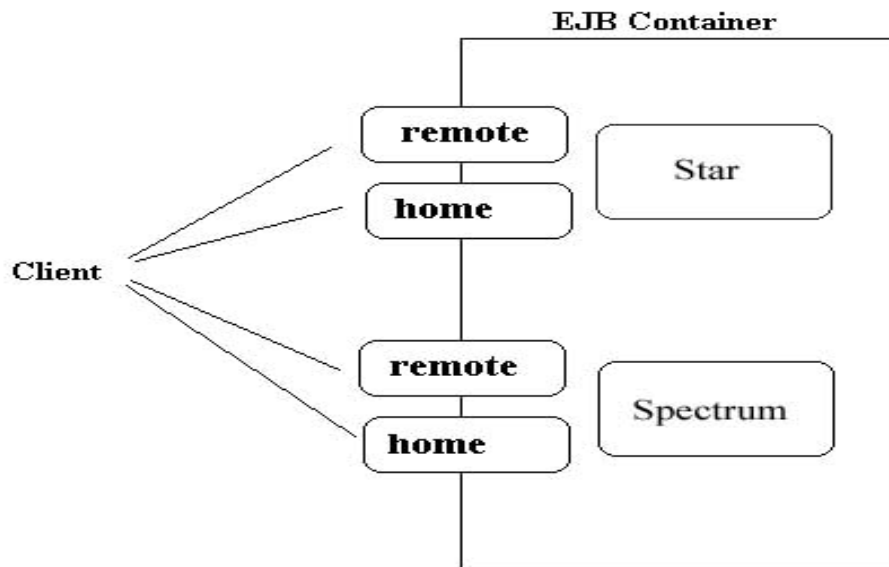

Vista conceptual de la arquitectura EJB

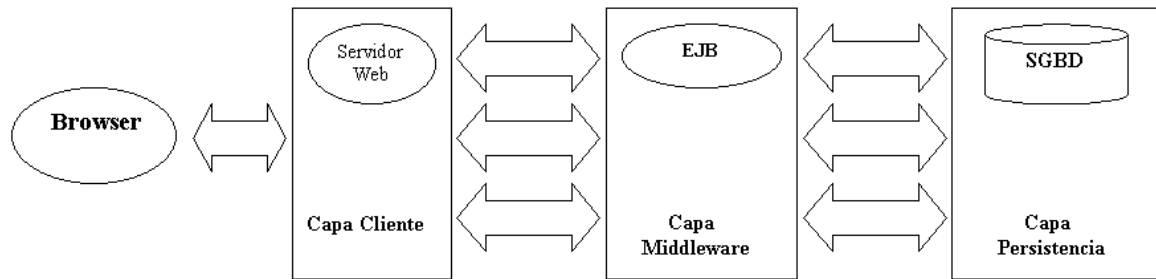

Visión global de la aplicación para explotación de BD espectral

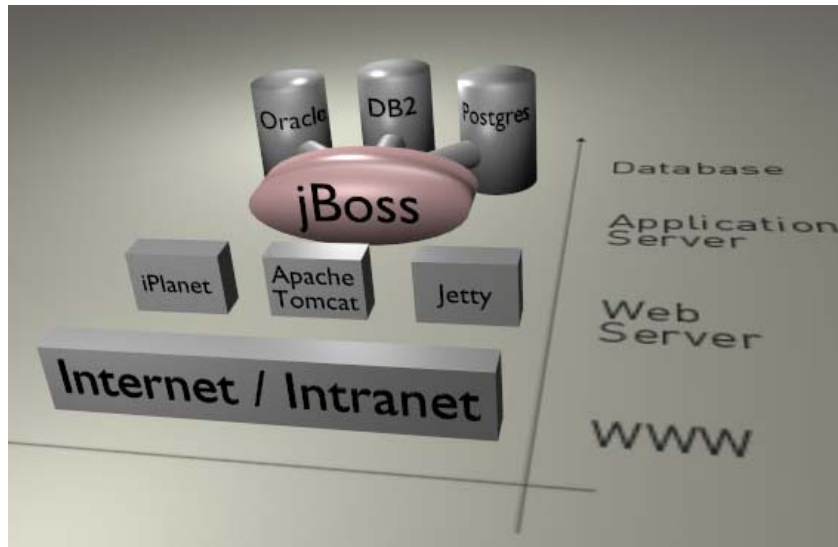

Visión general del sistema. Integración con Jboss

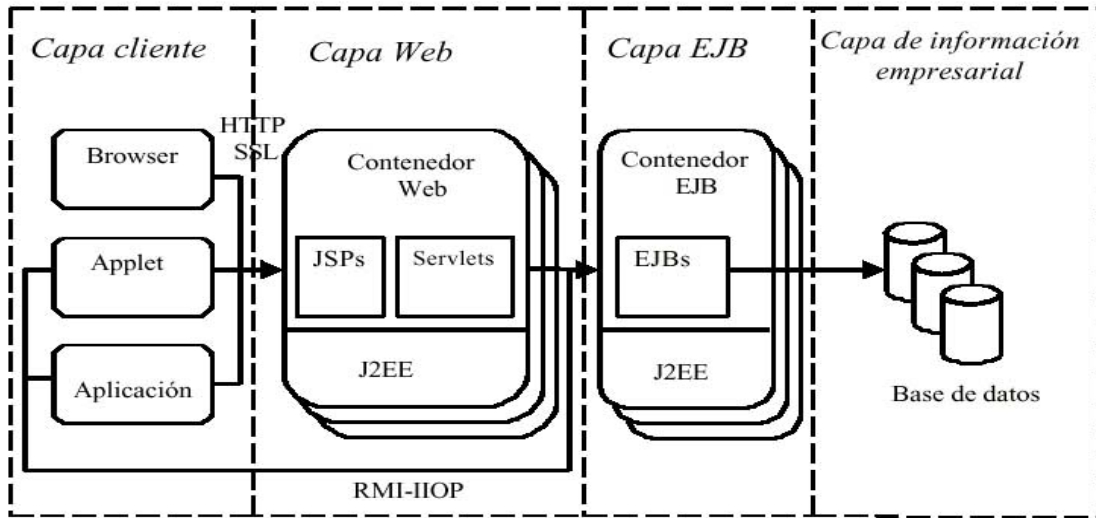

Arquitectura global del sistema

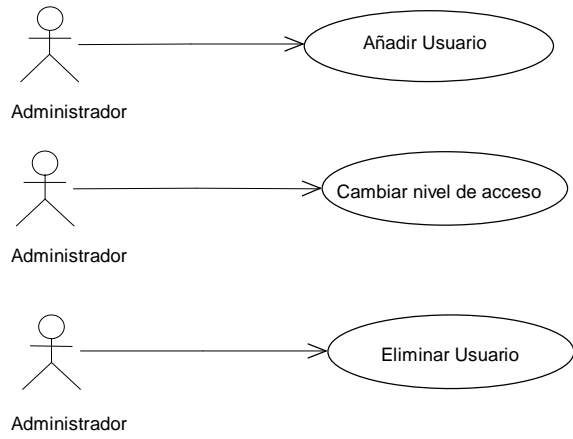

Casos de uso sobre tareas administrativas

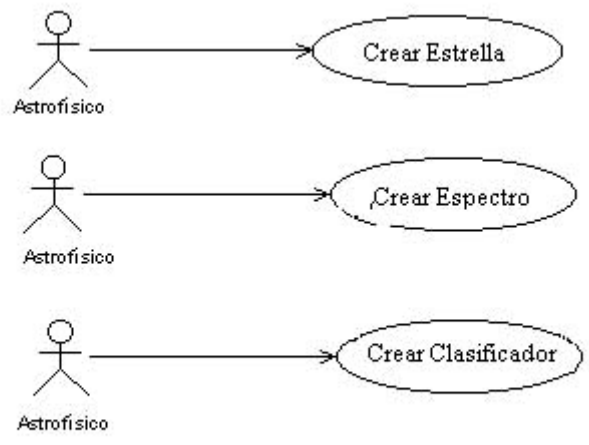

Casos de uso relacionados con la introducción de datos

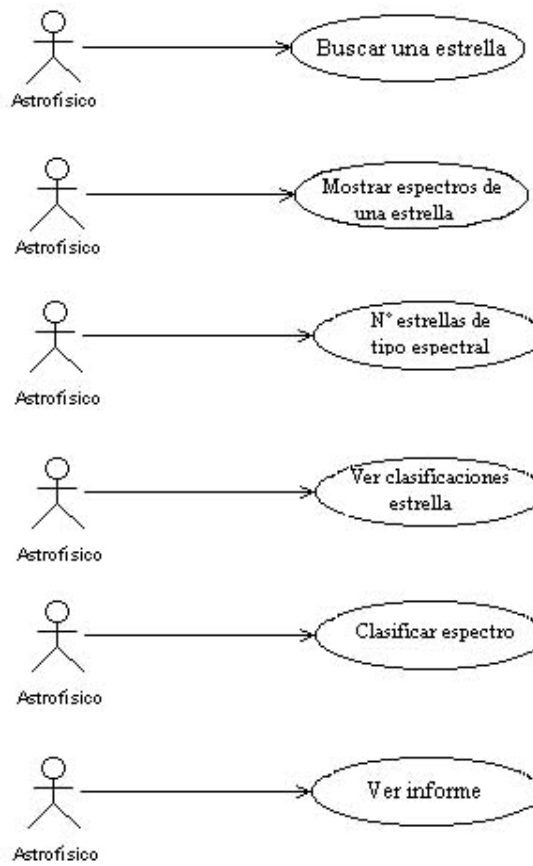

Casos de uso relacionados con la consulta de información

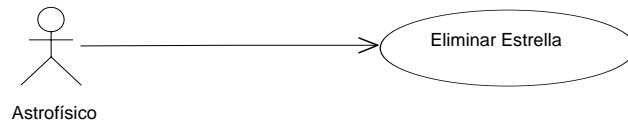
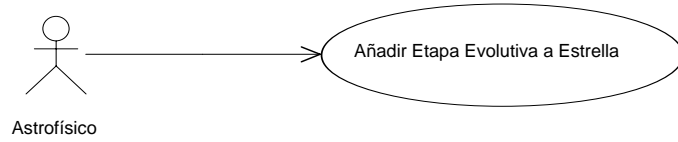
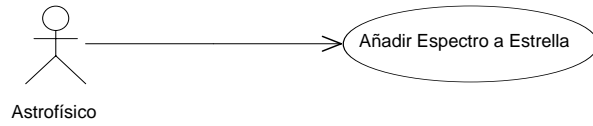
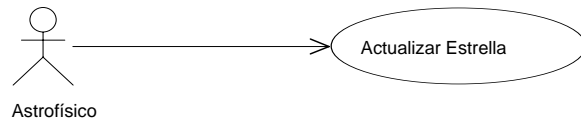
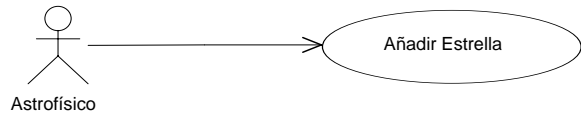

Casos de uso sobre una estrella

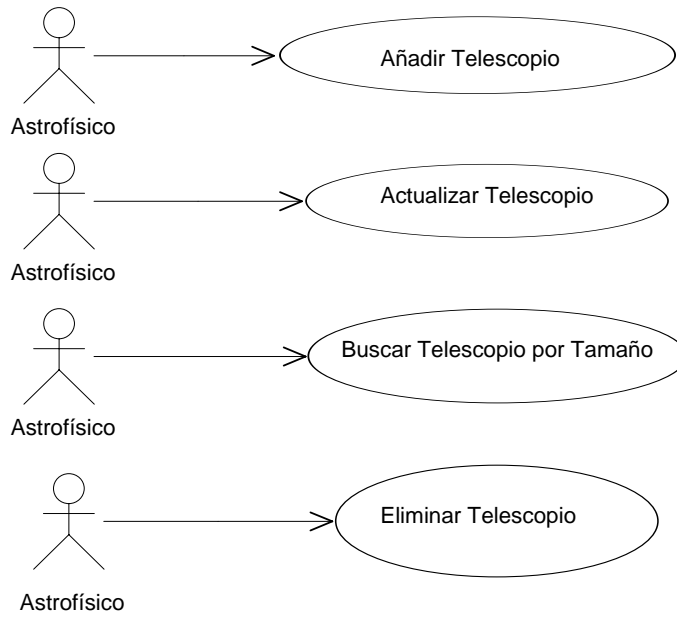

Casos de uso sobre un telescopio



Diagrama de clases de los interfaces Home y Remote



Diagrama de clases para la clase SpectrumBean

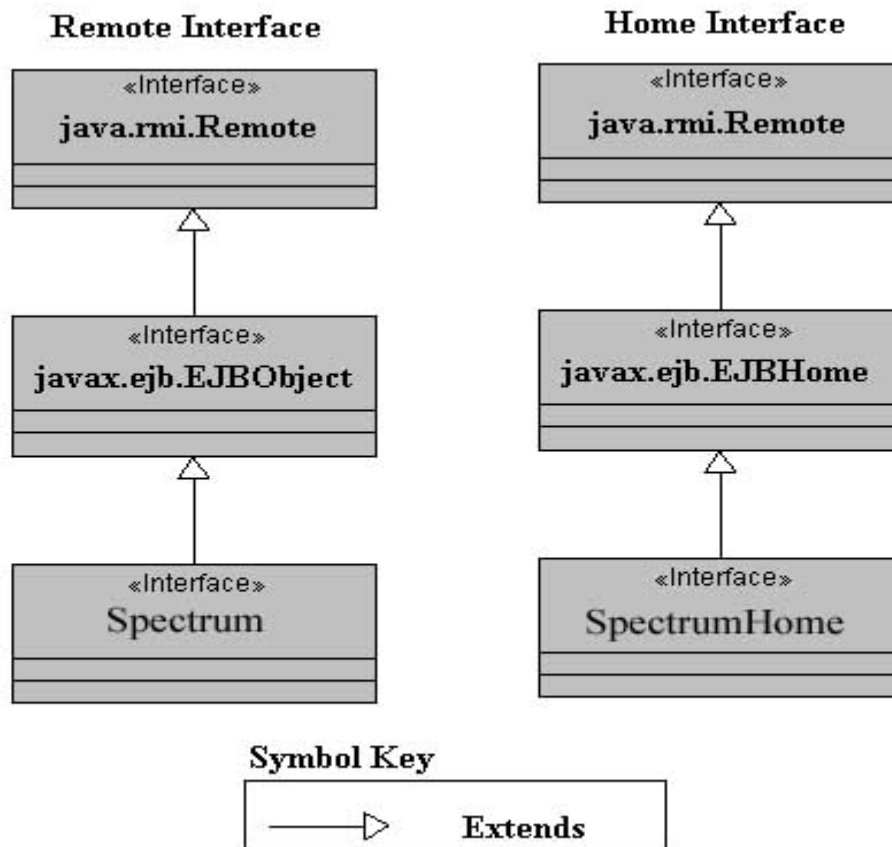

Diagrama de objetos general del módulo de análisis espectral

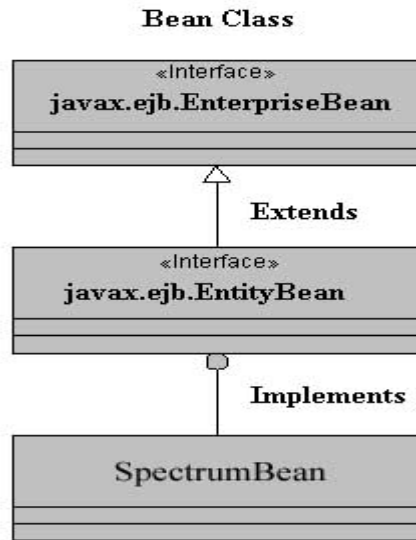

Diagrama de clases StarTypeDTO

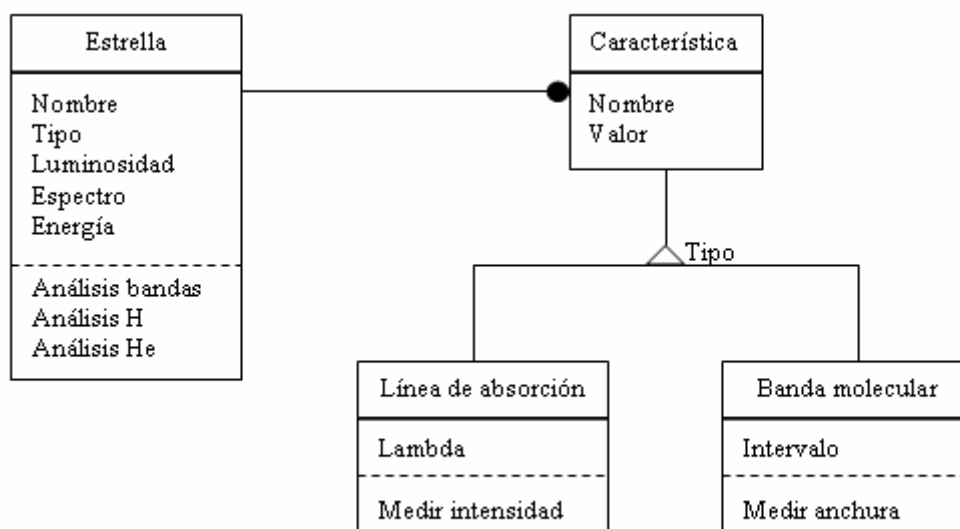

Diagrama de clases Classifier Search

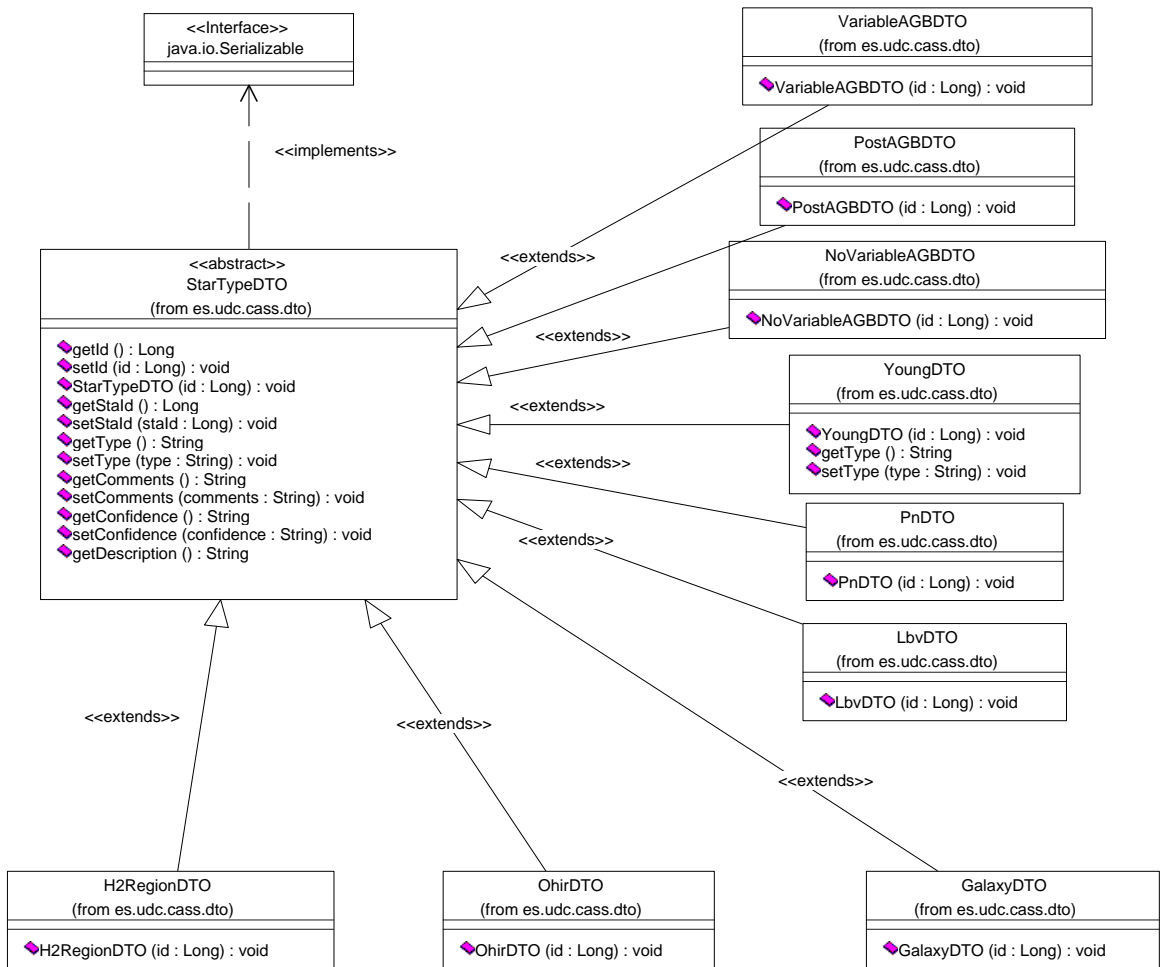

Diagrama de clases de la capa entidad del bean Star

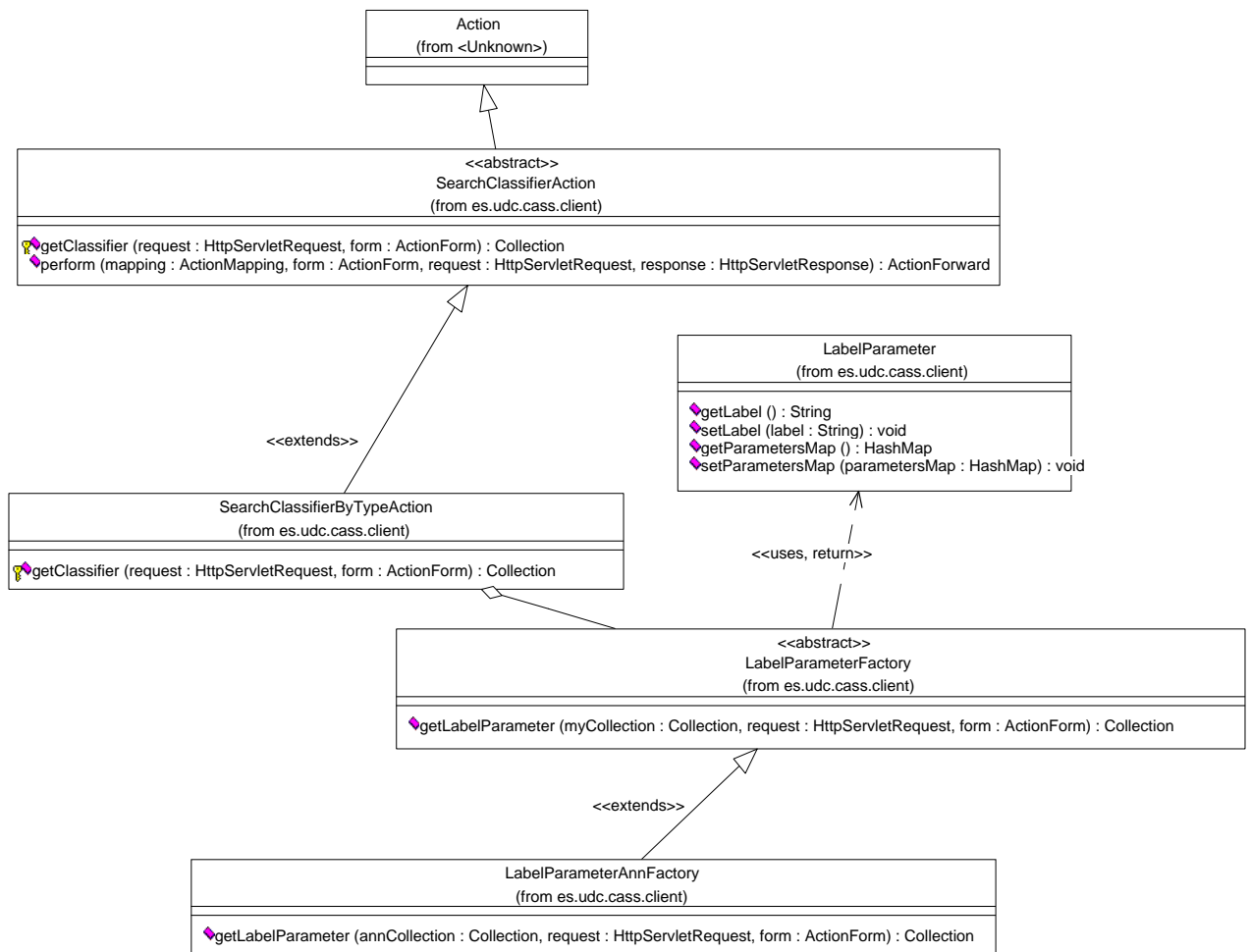

Diagrama de clases del patrón JDBC for Reading

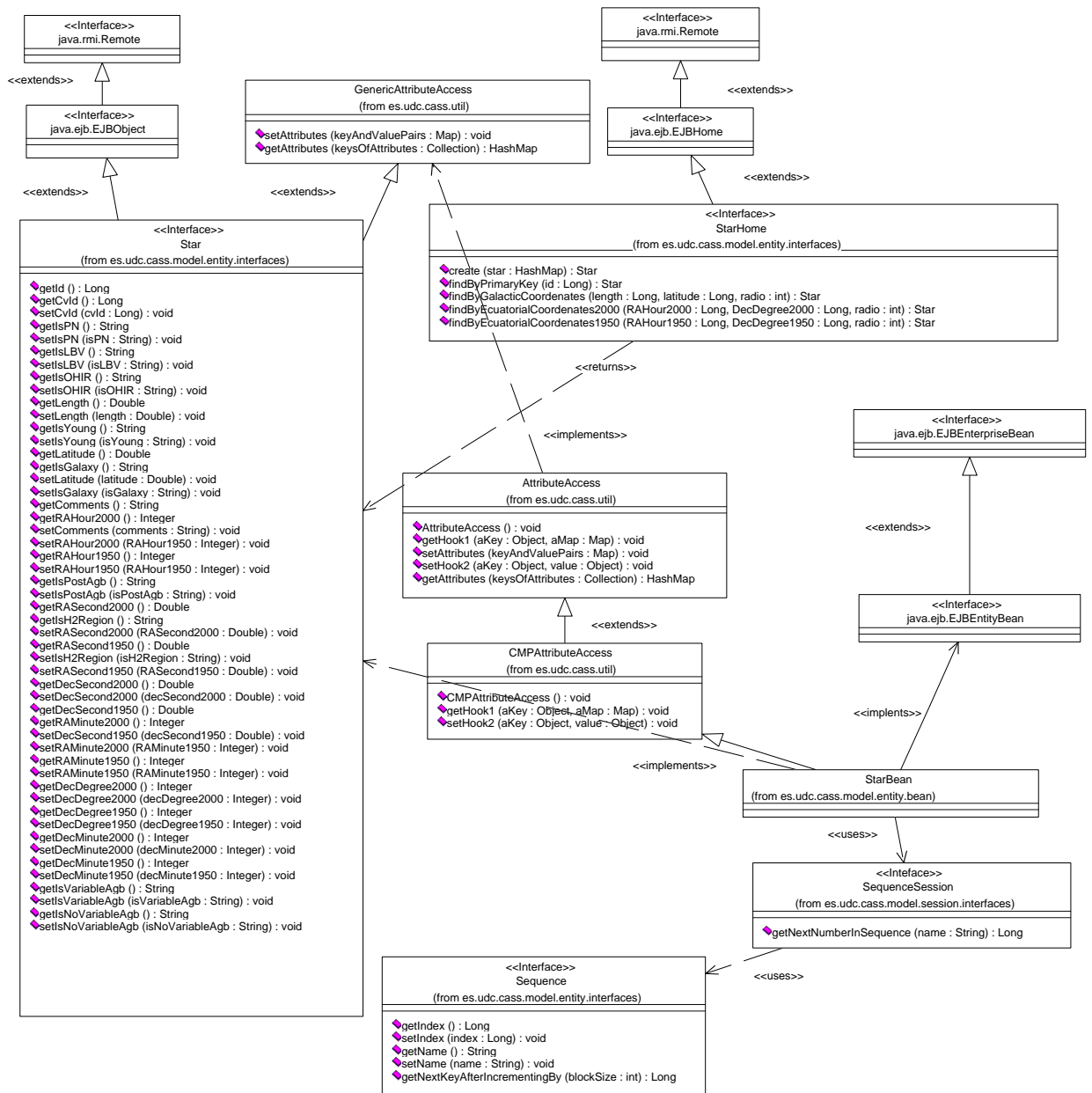

Diagrama de clases Entity Layer Telescope

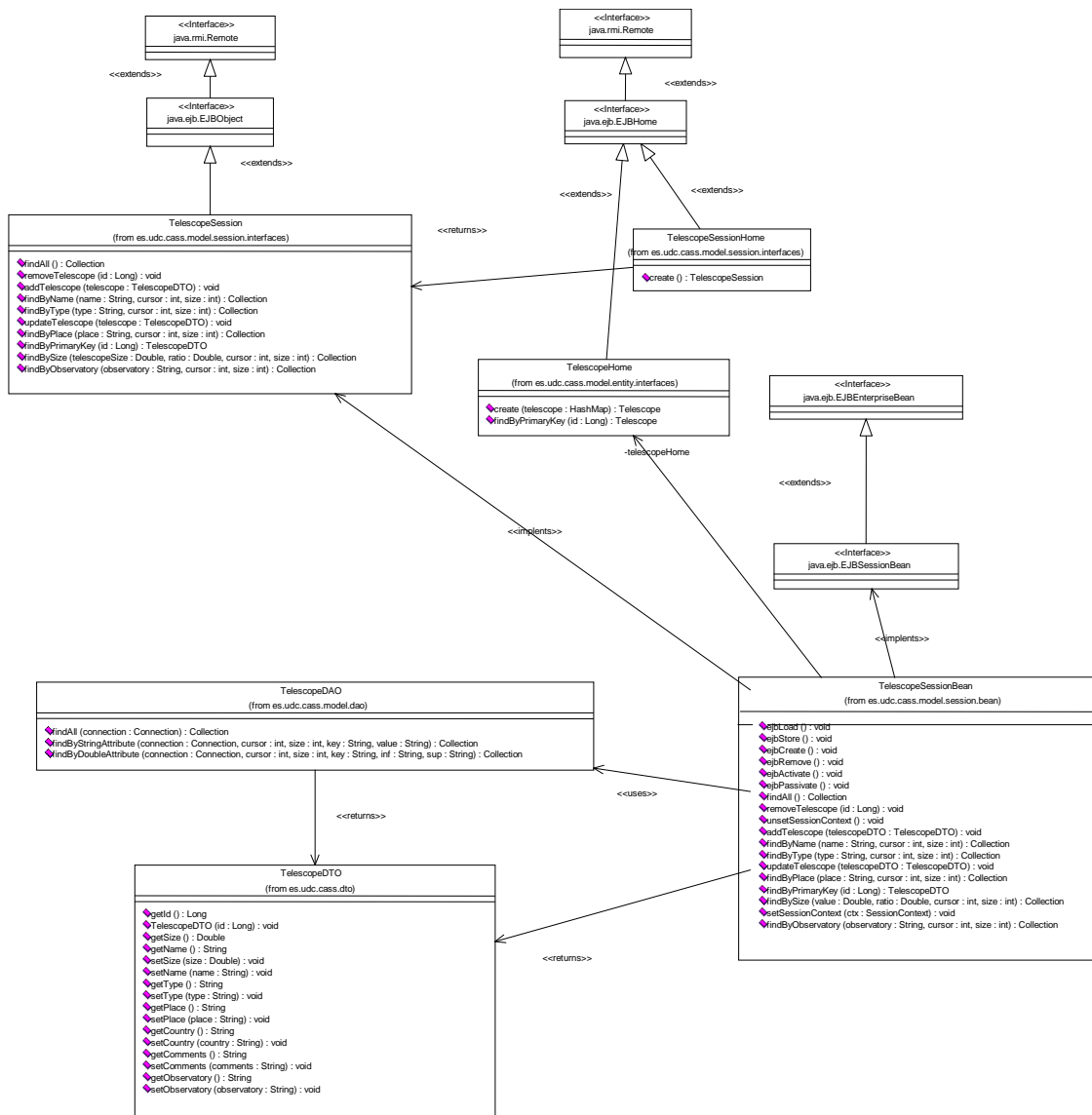

Diagrama de clases de la estrategia de generación de claves

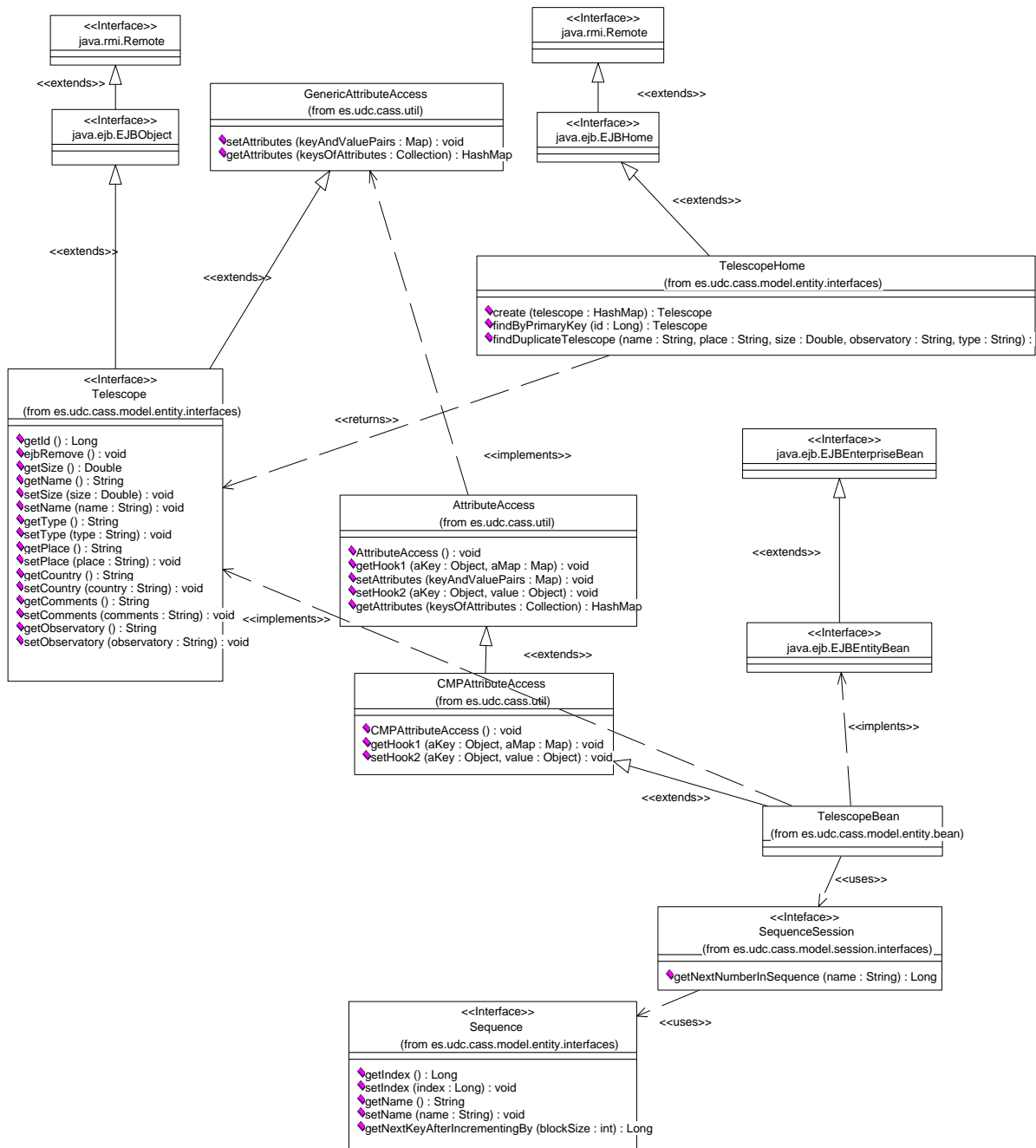

NOTAS

- ¹ Misma entidad: PERSONA
- ² Misma entidad: REFERENC

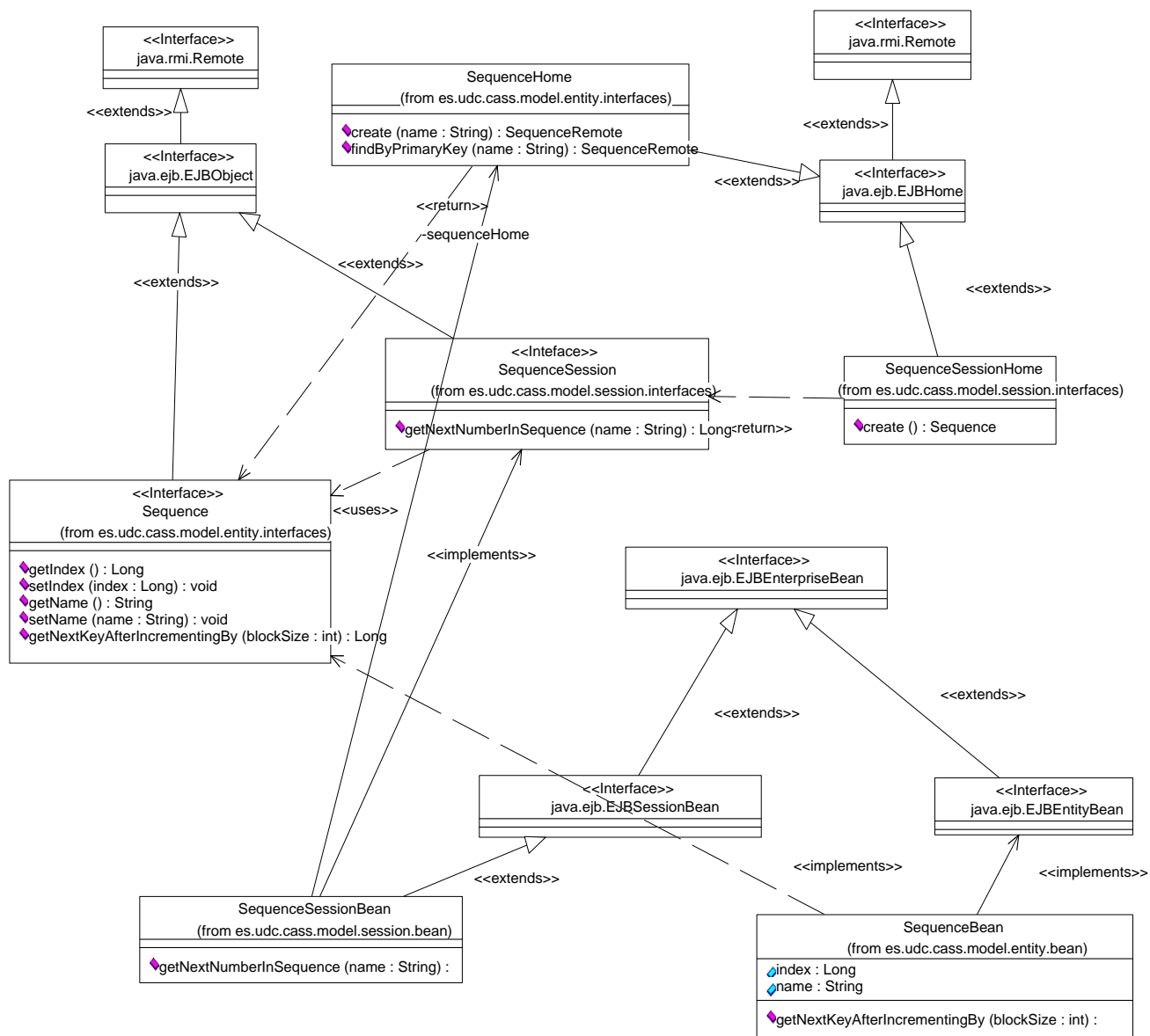
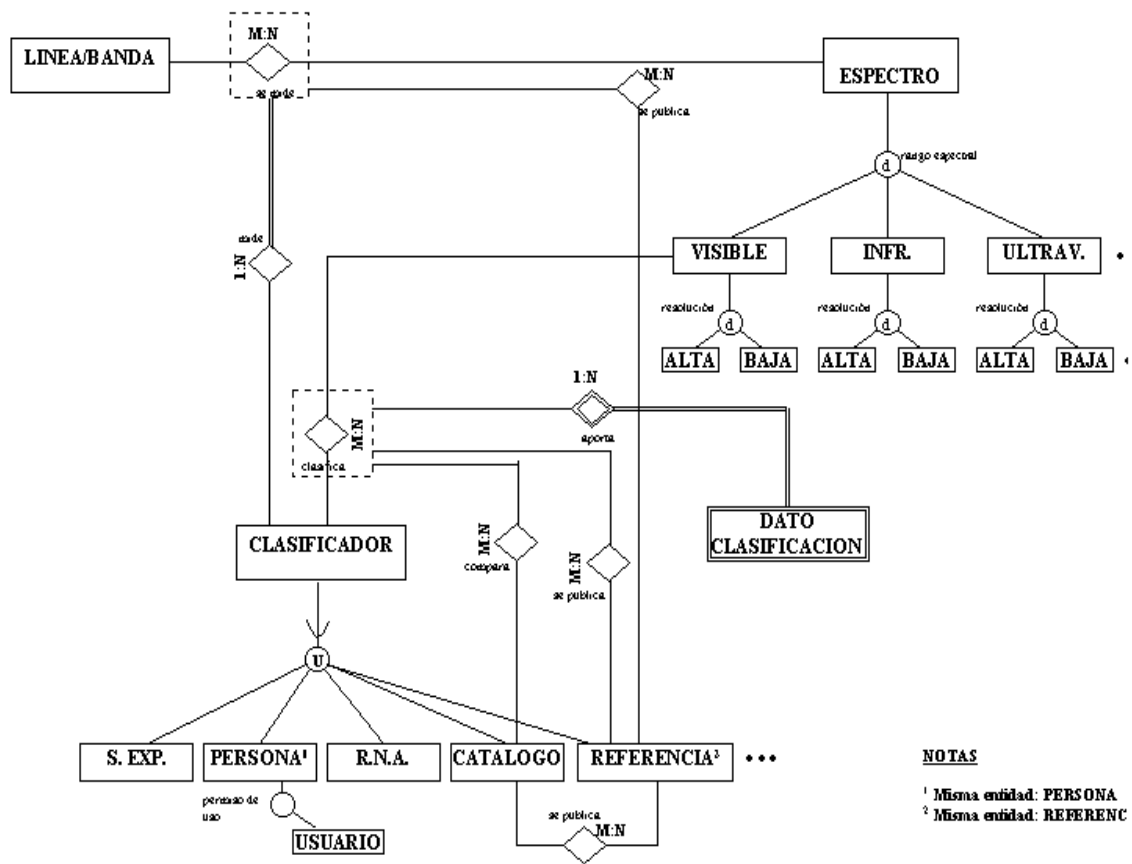
Diagrama Entidad/Relación parcial de la base de datos