



escolauniversitaria
POLITÉCNICA

UNIVERSIDADE DA CORUÑA 

TITLE	A COLLECTIVE REVIEW OF RENEWABLE ENERGY STORAGE TECHNOLOGIES (STUDY OF NEW ENERGY STORAGE SYSTEMS FOR OPTIMUM USE)
MASTER	ENERGY EFFICIENCY AND EXPLOITATION
SUBJECT	FINAL MASTER THESIS (TFM)
STUDENT	SOMAYA SALAMAH
SUPERVISOR	JOSE LUIS CALVO ROLLE & JOSE LUIS CASTELEIRO ROCA
DATE	SEPTEMBER 2019

INDEX TABLES

CONTENTS

ABBREVIATION	5
ACKNOWLEDGMENT	6
ABSTRACT	7
OBJECTIVES AND MOTIVATIONS	8
1. INTRODUCTION	9
1.1. Why Energy Storage.....	10
1.2. How is Energy Stored	10
2. HYDROGEN	11
2.1. Obtaining hydrogen	12
2.1.1 Electrolysis	12
3. HYDROGEN ENERGY STORAGE	13
3.1. Physical- based method	14
3.1.1. Liquid Hydrogen	14
3.1.2. Compressed Hydrogen.....	14
3.1.3 Combined (Hybrid) Hydrogen	15
3.2. Transporting Hydrogen	15
3.2.1 Restrictions	16
4. HYDROGEN APPLICATION	16
4.1. Hydrogen in transportation	17
4.1.1. Aircraft	17
4.1.2. marine	17
4.1.3. Trains.....	17
4.1.4. Buses	17
4.1.5. Cars.....	17
4.1.6. Industrial material handling	18
4.2. Electricity generation	19
4.3. Hydrogen Fuel Cells Advantages and drawbacks.....	19
5. THERMAL ENERGY	20
6. THERMAL ENERGY STORAGE (TES)	20
6.1. TES Benefits.....	21
6.2. Types of TES	21
6.3. Characteristics of storage system	22
6.4. TES Techniques	22
6.4.1 Brick Storage Heater (Electric Storage Heater).....	23
6.4.2 Liquid Nitrogen Storage	24
6.4.3 Molten Salt Energy Storage	27
6.4.4 Seasonal Thermal Energy Storage.....	29
6.4.5 Aquifers Thermal Energy Storage Systems	30
6.5. Thermal Energy Storage obstacles.....	31

7. COMPRESSED AIR ENERGY STORAGE (CAES)	31
7.1. Step by Step	31
7.2. Current Installation of the technology.....	32
7.3. Storage locations.....	32
7.4. Reasons for CAES application	32
7.5. The Future of CAES Technology	32
8. HIGH-SPEED FLYWHEEL	33
8.1. Applications.....	33
8.2. Advantages and Disadvantages of Flywheel Electrical energy storage	34
8.3. Future of Flywheel Technology.....	34
9. PUMPED HYDROELECTRIC ENERGY STORAGE	35
9.1. Reasons behind pumped Hydro Storage	35
9.2. Pumped Hydro- Storage discussion	36
9.3. Example of applied Pumped hydroelectric energy storage.....	36
10. RAIL ENERGY STORAGE	36
10.1. Technology behind the application.....	37
11. SOLID ELECTROCHEMICAL BATTERIES	38
11.1. Work process	38
11.2. Comparison between regular batteries and Solid State batteries (SSB)	39
11.3. Application of SSB	39
11.4. The Future Application of SSB.....	39
12. FLOW BATTERIES ENERGY STORAGE	40
12.1. Flow batteries Discussion.....	40
12.2. Redox Flow Battery	41
13.2.1 Advantages.....	41
13.2.2 Applications of Technology	41
13. SUPERCONDUCTING MAGNETIC ENERGY STORAGE (SMES)	41
13.1. Advantages of SMES.....	42
13.2. Purpose and Applicability	42
13.3. SMES Project Example	43
14. RISK ASSESSMENT OF ENERGY STORAGE	44
15. ENERGY STORAGE MARKET	45
15.1. Reasons behind the growth	45
15.2.1 VEHICLE-TO-GRID (V2G).....	45
15.2.1.1 V2G Application	46
15.2.1.2 Electric Car is the connection.....	47
15.2.2 V2H Applications	47
16. CONCLUSION	49
17. REFERENCES	50

LIST OF FIGURES

Figure 1. The Element of Hydrogen	11
Figure 2. An illustration of the electrolyzing process [12].	12

Figure 3. Simplified graphic of the nature of hydrogen storage methods.....	13
Figure 4. BMW Prototype 2011 Modular Super-insulated Pressure Vessel (Type III)[19]	15
Figure 5. Summarize the roles of hydrogen in reducing carbon pollution in some of the biggest sectors.16	
Figure 6. Real installation of both H2 Storage and the Application of it on Vehicles in Ciudad Real- Spain.	18
Figure 7. Presents the main components to produce AC or DC electricity.	19
Figure 8. The definition behind the physics of thermal energy [31].	20
Figure 9. Shows the influence TES has on improving Economy and energy management [33].....	21
Figure 10. Compiles the types of thermal energy storage.....	21
Figure 11. A common example of concentrated solar power generation system.[32]	22
Figure 12. System Schematic of ESH.....	23
Figure 13. System description of Liquid Nitrogen as a means of storing backup electricity	25
Figure 14. Transportation routes and methods of Liquid Nitrogen.....	26
Figure 15. Components of a Nitrogen powered car.	26
Figure 16. The liquid nitrogen powered Vehicle LN2000 – the car that runs on air.....	27
Figure 17. Concentrated Solar Power System with Molten Salt Energy Storage. Source: Jay Smith	28
Figure 18. The Navajo Generating Station incorporating Molten salt techniques in Southwestern Nevada, USA.....	29
Figure 19. Construction of Seasonal Heat Storage in Munich,5700 m3, 2007.....	29
Figure 20. ATEs throughout the year.....	30
Figure 21. A schematic of the Richard Stockton College aquifer system. New Jersey-USA	30
Figure 22. CAES Technology of power production. Source: Jay Smith.	31
Figure 23. Flywheel power storage technology	33
Figure 24. NASA G2 Flywheel.....	34
Figure 25. Pumped Hydroelectric Energy Storage	35
Figure 26. Genex Power’s Kidston pumped hydro storage located in North Queensland, Australia.....	36
Figure 27. RES project demonstration in Tehachapi, California	37
Figure 28. Rail Energy Storage Technology.....	38
Figure 29. Illustration of a conventional battery & a solid-state battery	39
Figure 30. The futuristic Solid State batteries with breakthrough development technology for energy storage.	40
Figure 31. Flow batteries illustration. Source: Jay Smith.....	40
Figure 32. Redox Flow Batteries. Lancaster, NY.	41
Figure 33. Superconducting Magnetic Energy Storage (SMES) Schematic design.	42
Figure 34. One of the world’s largest SMES magnetic storage tanks in Kameyama, Japan.	44
Figure 35. V2G Diagram of the application of the technology. Source: Jay Smith	46
Figure 36. Nissan Car with the demonstration of the technology V2G in Germany. Source: Nissan.....	46
Figure 37. V2G and V2H illustration.....	47
Figure 38. The V2H Technology applied [76].	48

[LIST OF TABLES](#)

Table 1. Demonstrates the efficiency of diesel powered vehicles and when converted to hydrogen[10].14	
Table 2. Pros and Cons of the technology.	34
Table 3. Indicates the technology Status belonging to SMES. Source: www.epri.com,2002	43

ABBREVIATION

Co2: Carbon Dioxide

H2O: Water

CH4: Methane

ICE: Internal Combustion Engines

TES: Thermal Energy Storage

ESH: Electrical Storage Heater

LN: Liquid Nitrogen

Cyro: Cryogenic

N2: Nitrogen

ATES: Aquifers Thermal Energy Storage

CAES: Compressed Air Energy Storage

V2G: Vehicle-to-Grid

V2H: Vehicle-to-Home

SSB: Solid-State-Battery

CNH2: Centro Nacional de Hidrógeno

PQ: Power Quality

HRS: Hydrogen Refueling Station

UPS: Uninterruptible Power Supply

RES: Rail Energy Storage

SMES: Superconducting Magnetic Energy storage

ACKNOWLEDGMENT

This humble work is a master thesis that was only achieved through extensive research and studies and the help and support of many people worthy of mentioning. I am very grateful for every single one of them. For both my parents (my precious mother and my beloved father) for the constant prayers and cheering through tough times where the lights were barely there until the sun shined on me, I thank them from the bottom of my heart. My sweet Sister (Arwa) and my lovely brothers (the close ones and the faraway ones) for their unimaginable encouragement and beliefs. My friends for the constant laughs and for making me feel at home even with a language barrier they taught me that love and compassion have no language and no limits. My far away people in a different land with different time zone staying up late to inspire me with their love you are always in my heart. My teachers and professors for the kindness and knowledge. To my two special supervisors for their patience and incredible support, Prof Jose Luis Calvo Rolle & Prof Jose Luis Casteleiro Roca. The journey has only just begun.

In this research you will find attached all the resources you need to acquire further knowledge in this vast topic. We are merely scratching the surface.

Por otro lado, me gustaría agradecer a todos por haber estado presentes durante este año de estudios. Gracias por las experiencias y por su amabilidad. Me gustaría agradecer a los chicos y chicas del máster, fue un placer conocerlos. En especial a mis amigas Rocío, Sonia, Noemi y María para una amistad de por vida.

ABSTRACT

The world of sustainable energy is evolving. Governments, industries, companies and even individually, everyone has been seeking the improvement and development of energy efficiency all around us. There has been so much evolution in the renewable energy sector, some energies more than other and some countries better than its neighboring. In this study we are going to focus on the energy storage part of the efficiency equation as a way for enhancing sustainability another step of the way. We are going to discuss the purpose and objective of such storages and the futuristic development along with their advantages and drawbacks, that could add efficiency and quality of life to our environment. We started with the Hydrogen part of storage in particular. Since the number one derivative of transportation energy is oil, and it is bound to run out. The focus has shifted to hydrogen as an alternative for oil. Hydrogen has been known for a long time now for having the characteristics that would give us matching if not better energy-wise results of a traditional energy, yet less harmful and more sustainable. Then we merge into Thermal energy storage the second largest part of the research, as how many technologies were developed as a part of this energy storage. Later on, the research takes into account further energy storage technologies and gives a review regarding each and every technology over 10 technologies explaining how they affect the development of the renewable energy in terms of enhancement and further goals achieving strikes towards a better environment and a better quality of life.

OBJECTIVES AND MOTIVATIONS

The aim from this review is to compile as much information regarding the energy storage technologies starting with hydrogen energy storage. Hydrogen is becoming rapidly the center of attention worldwide. The advantages that this element carries is largely growing by day. We try to pinpoint the exact transitioning that is occurring at the moment in the renewable energy era towards cleaner and more effective resources. We also try to explain the obstacles that we still face, and what the future has in store for hydrogenic storage technologies. We move forward from that to next chapter of energy storage technologies to thermal energy storage. Where we try to form a round understanding of such technologies and the different uses for it. Later chapters go into details with other more different technologies and try to give a collective review on them. This review humbly outlines the important information for anyone interested in the field of energy or simply any reader seeking a simpler guide towards understanding the history, the present and the future of such delicate yet powerful topic of energy storage technologies.

1. INTRODUCTION

Energy Storage is basically the produced energy captured at a certain time and then released for usage on a different time. This energy is saved in some sort of a device whether it be a batter or an accumulator. Those devices can save energy in the wide range of forms including electricity, elevated temperature, chemical, kinetic, gravitational potential and radiation. The purpose of energy storage is basically to transform un-storable energy into storable ones, such transformation is called energy storage technologies.

There are long term energy storages and short term energy storages technologies. Hydroelectric dams are a reservoir for energy storage as a gravitational potential energy mostly famous for being in both forms.

Obviously the most commonly used form of energy storages are the rechargeable batteries, they consist of chemical energy that has been prepared for producing electricity for demanded usage. Then there are the typical ones such as ice tank storages, where they store ice at night that is frozen for cooling during the day.

Since the world existed, human life has depended on energy in various ways. And the moment electricity was discovered it changed the way the world runs, and human technology began to evolve. The dependency we have on electricity and such technologies have become crucial in my opinion, and the world seems as it would collapse without it. The problem with that is the mis habits that the human life has been practicing obtaining energy is also dooming the world. Burning fossil fuels in order to produce electricity has been the number one source of energy technology for as long as we know it, this in itself has caused a tremendous amount of environmental damages that require immediate action. From air pollution, rising in CO₂ levels of emissions to global warming the atmosphere seems on the verge of imminent danger.

However, these concerns were met with disagreeing voices that weren't so keenly open to new reforms. With that being said, the intense rising of temperature and constant pollution has driven the balance off to the concerned association, and action were quickly performed. Renewable energies has surfaced, and the world began to breathe the new fresh air of possible sustainability without dependency of fossil fuel or carbon generating materials. From that point on, new technologies arises every now and then not only to generate electricity and energy but also to store what is left off as extra energy instead of being wasted.

As a result of this development, off grid electricity has become the epidemic sighting and the commonly used by capturing the electricity produced from renewable energies and even nonrenewable sources and using the energy storage technology to store those energies to be used at another time when needed. This allows consumers the chance to use energy while staying off the grid which gives them a complete control over the amount of energy consumption.

Combining energy storage with renewable energy can be extremely beneficial. Take for solar energy and wind energy for example, these two can be very unpredictable and vary depending on the weather, so consistency in their case is not a possible. But, with energy storage you can fix this equation by balancing out the days where you cannot depend on productive production of such energies. By that, we would have solved multiple issues. This would evidently include the reduction of CO₂ levels and the control over the energy consumption among other benefits.

1.1. Why Energy Storage

As previously mentioned, electricity grid depends on the power supply and the demand where they have to be somehow equal at all moment, the supply has to undergo continuous changing in order to be able to predict any changes that might occur in the demand, whether its human activity related, weather related or maintenance required. With energy storage in play, it takes the responsibility of controlling and balancing-out those inconsistencies to help the grid sustain a reliable system.

Energy storage are quite important especially when the demand is further from the electrical grid. When you are around a source of electricity that produces a certain necessity for your such as light, this electricity is generated from the grid; though if you are away from any source of electricity you may rely on a portable-battery powered light source. The same concept applies on buildings when its closer to the grid it is easily supplied with electricity but when its farther, energy storage ensures the stability in supply [1].

There much more benefits for energy storages than just consumption [2]:

- Environmental benefit: reduction of Carbon footprint by using renewable energy.
- Economic benefit: increasing wind and solar power value.
- Security: efficient performance grids that are uneasily disrupted.
- Employment: creation of new field of jobs in many sectors to support the technologies.

1.2. How is Energy Stored

We established that energy storage can provide stability, economic flourishing and environmental advancement. The next step is to explain how we store energy. There are various way to do so, such as [3]:

- **Batteries:** large batteries are able to store energy for when demanded. Batteries use lead acid, lithium iron for their technologies.
- **Flywheels:** a rotor, in a rotational kinetic energy, that spins when energy is needed a generator from which electricity is produced.
- **Compressed air:** it is the use of electricity to compress air underground caverns. The compressed air is released when electricity is needed, the expansion of the turbine generator will produce the electricity.
- **Thermal Energy Storage:** it is the use of storing changed temperature to be used later when needed such as heating and cooling.
- **Pumped hydroelectric:** through the use of gravitational potential energy by pumping water up into a reservoir, the water released from elevated position to lower position into a turbine it generates electricity.
- **Hydrogen:** is considered a zero carbon fuel. It can literally be used as gas fuel to power engine, motors and vehicles.

There are more technologies everyday being discovered, some are being considered and others are being developed at the moment. The work of energy storage technologies is never done it is constantly improving.

2. HYDROGEN

Since we can't depend on fossil fuel forever, humanity has to find a different sustainable carrier that can fulfill the needs and requirements for mobile activities efficiently. Appropriately, hydrogen is the only known energy carrier that can be produced in an enormous amount in fairly considerable time span [4].

It is remarkably efficient and clean; we can produce hydrogen through renewable energies such as solar energy and wind from water through electrolysis. This is a closed cycle production; the hydrogen returns back to water through combustion.

Hydrogen has been around for centuries; it has been used in countless materials and purposes. It is used in batteries, switchable mirrors, sensors it is also in chemical engineering [5]. The current and most demanded use for hydrogen is an alternative energy fuel. Using renewable energy to produce hydrogen through electrolysis. When renewable energy resources production become momentarily unreliable, the hydrogen stored is used to produce electricity [6]. According to Cavendish, hydrogen is 7 times up to 11 times lighter than the density of air. He was the first to measure that and then went to call hydrogen "inflammable air". With his calculation, eyes were drawn towards hydrogen for its specific and unique features that makes it more capable of being an alternative to traditional fuel. After that discovery was made public a man by the name of Alexander Cesar Charles, took full advantage of that discovery and performed his own experiment. On the 27th of August Charles released his first trial of a hydrogen balloon, only to become 3 months later the first man to have flown in a hydrogen balloon [5]. From that moment onward, complete focus was given to hydrogen above all, in order to take full advantage of it.

Unfortunately, not all attempts were met with successful results, such as Charles'. Multiple tragedies happened not so long after that experiments that resulted in two fatalities, after the balloon ignited. But that didn't stop the rapid interest in hydrogen, as buoyant gas for about 150 years, until the tragedy of 1937 explosion that ended the use of hydrogen in air applications [5].

Nowadays, fuel cells and hydrogen are considered as one of the primary solutions for our century. It will be put to use in transportation industry which will significantly lead to mass reduction in pollution and environmental defects [7]. However, to completely transition from fossil fuel and carbon-based to hydrogen-based system is not as simple as it may seems. This requires intensive and full resources kind of focus to achieve such transition. It will be faced with many challenges and obstacles, scientifically and economically. Regardless, with consistency and devotion to implement the technology for a better clean energy, this can be done. The attention is concentrated now on carbon-based elements for their availability, easy-to process, stability and their flexibility to turn their fundamental anatomical features to match the demand of a certain application. Porous carbons lead the search with their dominance in the energy field of applications. Along the benefits and advantages, it includes the low density. The most currently exploited class of porous carbons are activated carbons, they are the most absorbent of materials but recently they have been used as a hydrogen storage materials [8].

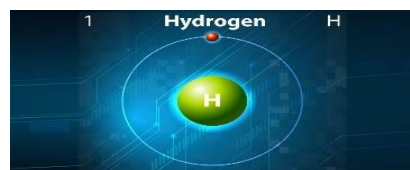

Figure 1. The Element of Hydrogen.

2.1. Obtaining hydrogen

For a century now, hydrogen has been commercialized and been processed in multiple goods. Ammonia has been developed in the 5th year of the 20th century through hydrogen and a mix of nitrogen in the air. The uses for ammonia varies between cleaning products, liquid fertilizer and insect repellent. Later on, it has been involved in a lot of explosives. Hydrogen has been known to be used for the hydrogenation of fats and oils, methanol production, rocket fuel and the production of hydraulic acid among other things [9].

In order to produce hydrogen, two sources will be needed a hydrogen one and an energy one. In today's world natural gas is the cheapest form of a hydrogen source, it is a combination of energy and hydrogen source. But it only contains 50% chemical energy as a hydrogenic result. Another way of obtaining hydrogen is through oil but that is the worst case of energy efficiency. If it's obtained from fossil fuel, there will always be carbon dioxide along with greenhouse gas discharge [10].

Hydrogen commonly found in combination of other elements. Combined with oxygen it forms water represented as (H₂O) and combined with carbon forms methane (CH₄). In order to obtain the purest form of hydrogen, it should be detached from its element companion [11].

There are three common processes for the production of hydrogen:

- The gasification of charcoal: charcoal is made up of water and carbon. When heated at an extreme level of heat up to 1500 °C, it would result in a combustion of gas which then renovate into hydrogen and carbon monoxide.
- Methane- reforming: the most commonly used in the hydrogenic production processes using natural gas. The reforming of methane under high temperature steam. This causes the methane to break and the atoms to separate. When repeatedly done twice, they result in the production of hydrogen and carbon dioxide. Costs around € 1.5 per kg
- Electrolysis: passing a current through water causes it to split (H₂O) into hydrogen (H₂) and oxygen (O₂). This is a cheap method compared to obtaining hydrogen through fossil fuel. Yet, it is still 4 times more expensive than producing hydrogen through steam methane [11].

2.1.1 Electrolysis

To simply put it, electrolysis is the use of electricity on water leading it to split into oxygen and hydrogen. The process happens in a contained unit called the electrolyzer. The units vary in sizes depending on the amount needed. They can be directly connected to renewable energy sources or any non-pollutant-emitting source of electricity generation [12].

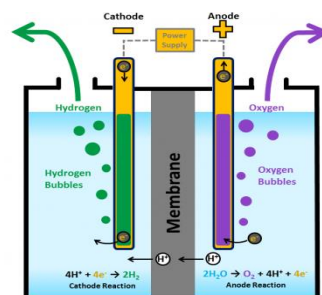

Figure 2. An illustration of the electrolyzing process [12].

3. HYDROGEN ENERGY STORAGE

Hydrogen has the advantage of being able to produce it through renewable energy and for being able to store it at a large quantity over long period of time. This will cause a huge transition in the energy sector along with the business one. The main part of human life quality is the transportation sector. It is what most focus on. With hydrogen abilities in the picture, there is a possibility we can achieve that [13]. With achieving energy storage and combining them with the battery systems we may able to perfect the optimum vehicle. Hydrogen is capable of providing a great volume of energy storage, while batteries would allow the system to reach maximum power needs and work as a buffer between the load changes and fuel cell over a long period of time [14].

Unfortunately, it is not easy to store hydrogen for the lack of energy density. It is considered to be the lightest element. It is 3,2 less dense than natural gas. In order to be able to use hydrogen in transportation it has to become denser since it is 2700 times less than gasoline [11]. similarly, to be able to store hydrogen, and for better handling the density must be increased unquestionably.

Currently there are new technologies being tested and tried for storing hydrogen. Regardless, the commonly known method revolve around two basic ones, the Physical storage and the Material storage. They have been tried at length and extensively. The physical methods consist of Liquid Hydrogen, Compressed hydrogen and combined hydrogen. The new materials that are being tested at the moment are grouped in the materialistic section [14].

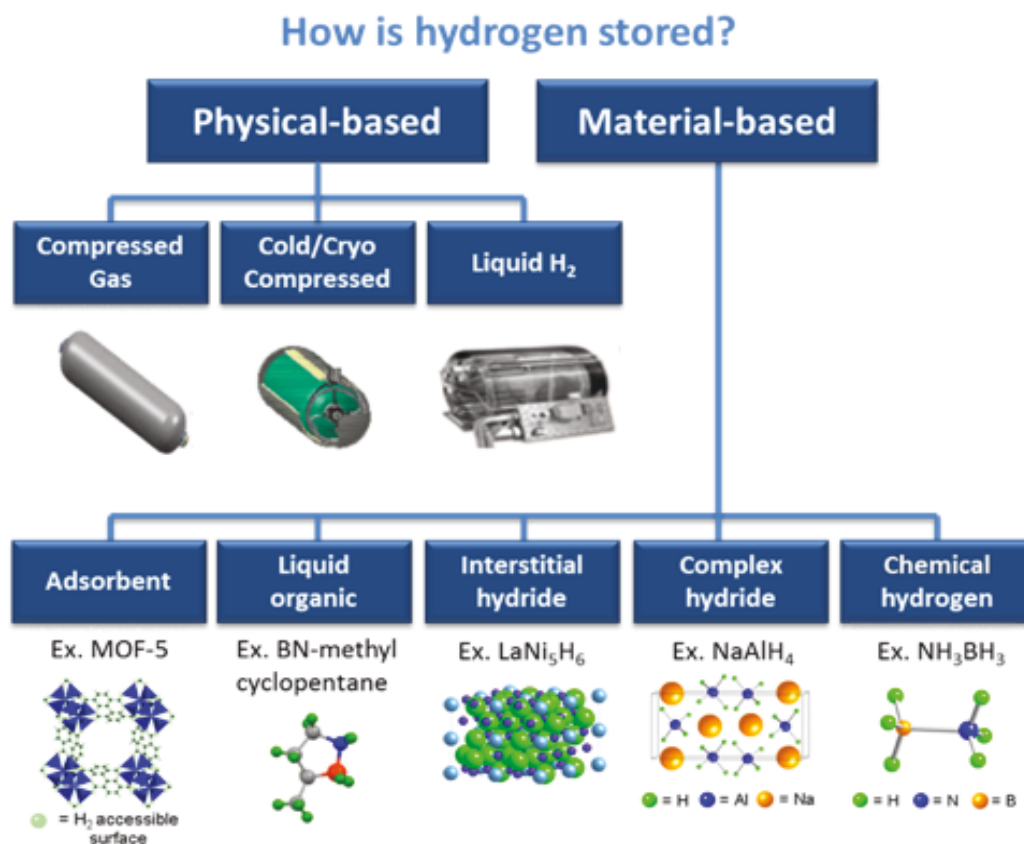

Figure 3. Simplified graphic of the nature of hydrogen storage methods.

3.1. Physical- based method

3.1.1. Liquid Hydrogen

When hydrogen is the liquid state(cryogenic), its volume is increased up to 3 times more than gasoline even for the same amount of energy. When hydrogen is in a liquefied form the tanks are much lighter. Unfortunately, there are energy losses during the liquification process that could reach up to 30%. The only thing colder than liquid hydrogen is liquid helium [10]. This is an advantage, since liquid hydrogen is easily stored in a light weighted tank. The description of a liquid hydrogenic tank is like a flask or a thermos made out of 2 layers within these layers of tanks is a vacuum. The inside tank has to be backed without transporting any heat.

The demand on liquid hydrogen is quite popular these days for the common application for it as known in chip industries. The problem with liquifying hydrogen is that it necessitate for liquification at $-253\text{ }^{\circ}\text{C}$, and that requires specific machinery that are quite costly. During the storage process of liquid hydrogen, heat must be avoided at all cost, by insulating the tanks to avoid heat caused by conducting or radiation that would lead to evaporation [14].

3.1.2. Compressed Hydrogen

Contradictory to the liquid hydrogen storage, compressed hydrogen is in the form of gas. Along with being under high pressure. This more commonly used due to the compatibility on automotive systems, since gaseous hydrogen is known for extreme refueling, superior inertness characteristics, and shallow impact on the infrastructure [15]. Hydrogen compressed gas to about 800 bars around 6 tons, for each square inch. This kind of impractical and boarder line risky to try and contain that amount of pressure in a tank that is lightweight. This could easily lead to a disastrous explosion when a tank pressure failure is released abruptly [16]. it's quite the illogical situation when the steel tank of compressed hydrogen weighs as much as the vehicle it supposed to power. There is a solution currently being processed, using carbon fiber tanks to store high pressure hydrogen. It has been known that carbon fiber is a lightweight material that is effective and is being used currently in aircrafts. The problem is they are quite costly [9].

	weight of fuel	weight of steel tank	weight of carbon fiber tank	volume of tank contents	volume of tank
typical 18 wheel truck (diesel)	1175 lb	(small)	NA	22.5 feet ³	24.0 feet ³
typical sedan (gasoline)	108 lb	(small)	NA	2.25 feet ³	2.5 feet ³
truck converted to ICE hydrogen	313 lb	31,300 lb	6,960 lb	67.5 feet ³	157 feet ³
sedan converted to hydrogen fuel cell	17.4 lb	1740 lb	387 lb	4 feet ³	9 feet ³

Table 1. Demonstrates the efficiency of diesel powered vehicles and when converted to hydrogen [10].

The first diesel truck carries out two separate 90 gallons tanks. It achieves 35% efficiency at a regular speed. The gasoline sedan carries 18 gallon tank. Efficiency of 25%. When converted to hydrogen process, the internal combustion engines on the truck converted results in an efficiency of 35%. Using fuel cell on the sedan results in a 45% efficiency [10].

3.1.3 Combined (Hybrid) Hydrogen

As we explained the compressed hydrogen process and the cryogenic process separately, they can actually be merged together in one combined process [17]. This method is already out and operational. The results of compressing cooled hydrogen lead to the improvement and advancement of the hydrogen storage. The benefit of this method is the combination of cryogenic hydrogen compressed, gives it a higher density contradictory to compressed hydrogen separately. Nevertheless, this process is energy draining [18].

3.1.3.1 BMW Cryo-Compressed Hydrogen Storage development

BMW is currently working on developing the hybrid hydrogen technology into its vehicles. Prototype2011 has went under testing for operating pressure, vent pressure, refueling time, system volume, system weight and H2 Loss [19].

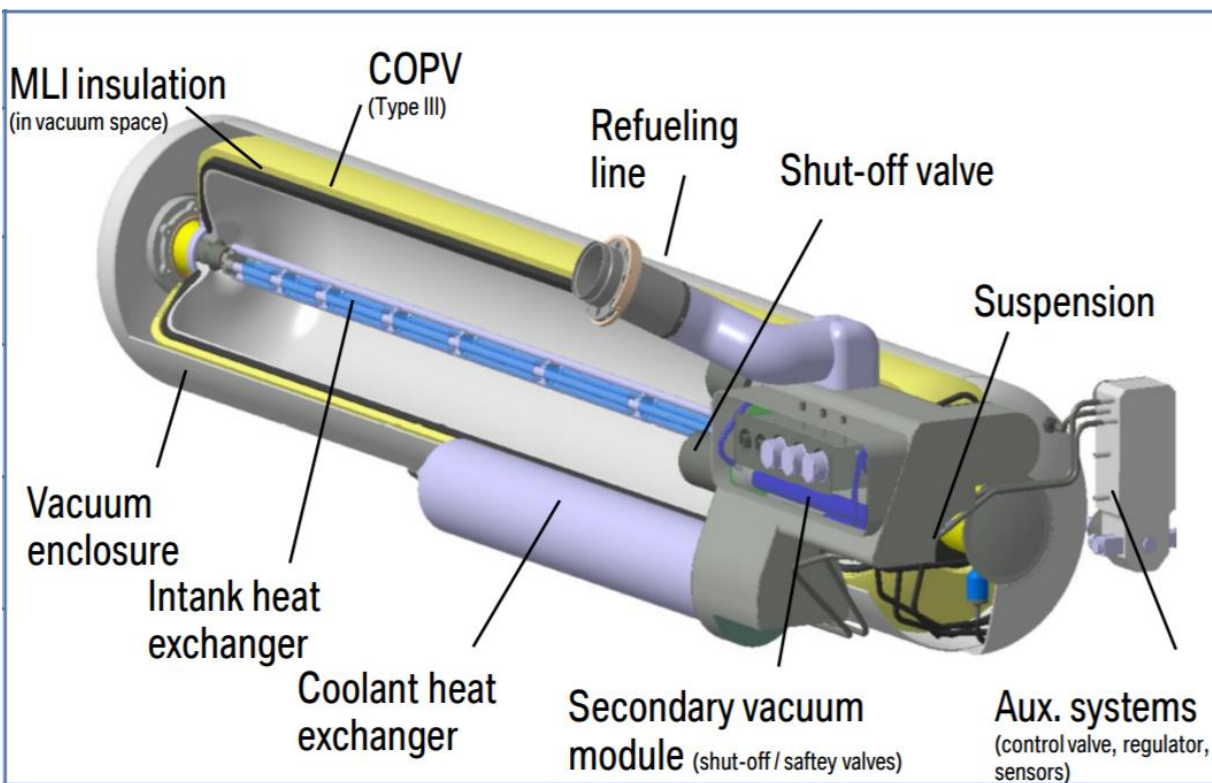

Figure 4. BMW Prototype 2011 Modular Super-insulated Pressure Vessel (Type III) [19].

3.2. Transporting Hydrogen

At the moment hydrogen is being transported from the point of beginning of production to the step of use through pipelines. Either on the road through trucks carrying cryogenic liquified tanks of hydrogen, trailers of gaseous tubes, or large work boats. Later on, they can be stored at the facilities in specified cylinders.

When it comes to fuel cell it is distributed almost the same as you would with gasoline. Where the responsible drivers of a vehicle would park into a station assigned for filling, which then they proceed to hook the distributor to the vehicle, fill it up, unhook, proceed to compensate to a full tank. This whole process takes almost as much as refueling gasoline, a little under 5 mins [20].

3.2.1 Restrictions

There are a couple of challenges that restricts hydrogen delivery from becoming fashionably available everywhere. The cost of delivery takes a toll on the distribution process, losses in energy efficiency, hydrogen impurities, and hydrogen losses and leakage [20].

Convincing the developers and shareholders in the economic sector into investing in the hydrogen delivery foundation is a huge obstacle. This is going to be a long road towards education and achieving desired results along with excessive and intensive constant development and search for new technologies. It is fair to mention, that the delivery of hydrogen varies from region to another, it depends on the area, the demand and how developed the market is [21].

4. HYDROGEN APPLICATION

Since the discovery of hydrogen, the element has been used for many reasons. It has been popular later on for commercial uses rather than just scientific experiments or researches. This would entail [22]:

- Rocket fuel along with Fuel production
- Balloons (it is highly flammable)
- Production of ammonia

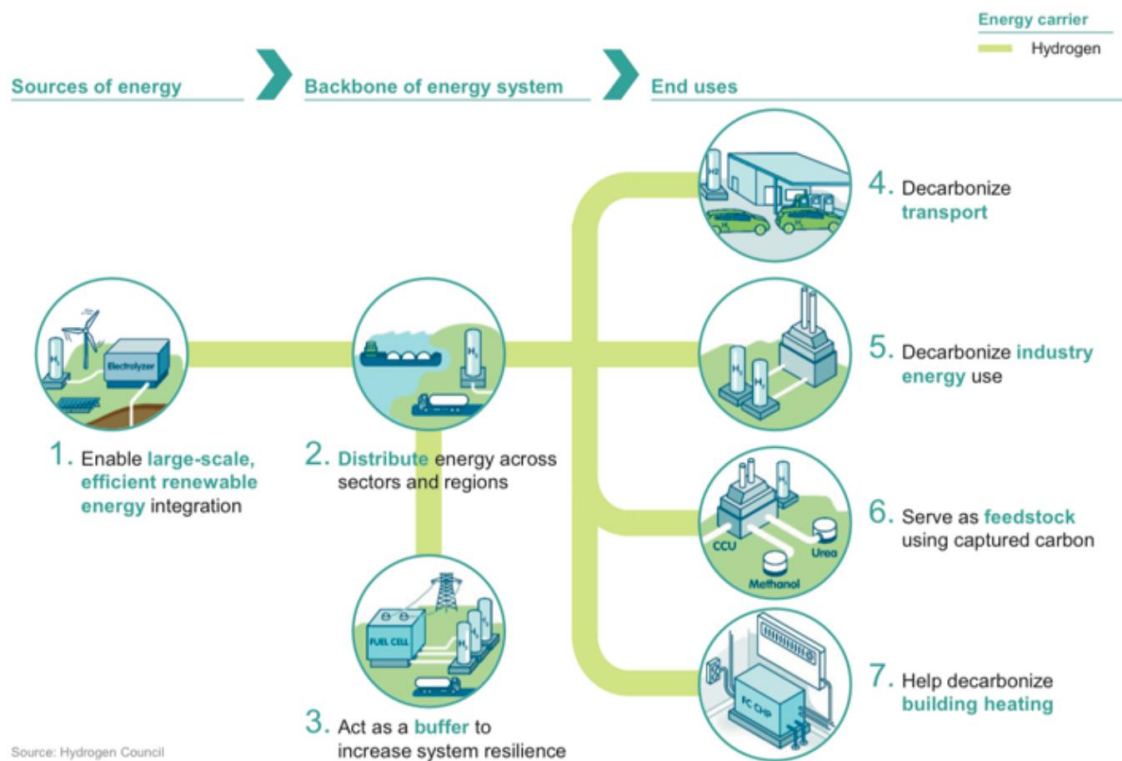

Figure 5. Summarize the roles of hydrogen in reducing carbon pollution in some of the biggest sectors.

Hydrogen is being used for as a material based and as an energy based. The material based include the production ammonia through the combination hydrogen and nitrogen. Ammonia is the number one product that goes into making fertilizers. Hydrogen is also present in a lot of industrial productions such as production of flat glass, electronic industries, metal blend and cleaning applications [23].

4.1. Hydrogen in transportation

The main attraction lately have been on the transportation sector and how we can improve making it an efficient, anti-pollutant, greenhouse gas non-emitting and a way to decarbonize the sector. Since the early appearances of hydrogen on the laboratory tables, it struck as a valid candidate to replace the traditional and harmful carbon-based fuel. We can produce a clean hydrogen fuel through a renewable energy source with the electrolysis process. With this process we have the benefit of producing a zero Co2 emitting fuel for vehicles. This has higher efficiency than internal combustion engines (ICE) producing fuel cell.

4.1.1. Aircraft

Since hydrogen fuel cells have been functional in space travel for a while now, it has been considered for civil aircraft. With the same concept of fuel cell supplying electricity to the civil aircraft as a supplementary power unit. The future study now is trying to develop the concept on commercial aircrafts [24].

4.1.2. marine

currently testing fuel cell to be the main provider of energy for the ship power supply. This is still on trial bases an hasn't been permitted for public use yet. However, it is being tried on small ferries.

4.1.3. Trains

Rail vehicles that are powered by hydrogen or fuel cell have the absolute advantage over traditional rail vehicles being a zero- greenhouse gas emitting and the considerable low cost of construction and maintenance in comparison with the diesel fueled rail vehicles.

4.1.4. Buses

Nations worldwide are depending on public transports; buses carry out the majority of these transportations and therefore the highest percentage of carbon dioxide emitting comes from buses. The development of hydrogen powered buses is not a new development, though the main focus currently is the fuel cell electric buses. It is currently being commercialized and promoted as the new image of clean energy. The Electric buses are at all time state of the art technology powered with smart technical systems. The drawback to this is the very expensive cost of such vehicles at around of 1 million Euro. However this price is expected to drop and continuously so in the near future with more projects coming to light.[24]

4.1.5. Cars

The only two type of cars that are zero-emitting are the battery powered electric vehicles and the hydrogen fuel cell powered cars. At the moment, many automobile manufacturing companies are working on a full series of cars to be released for commercial use competing against conventional vehicles. Unfortunately, the price is still the main issue for this kind of development although it is predicted to fall extensively.

4.1.5.1 Hydrogen Vehicles Real Applications

Currently in Spain there is an organization called Centro Nacional de Hidrogeno (CNH2), responsible for manufacturing hydrogen fuel cell for vehicles and refueling stations (HRS) and hydrogen storage tanks.

The HRS that are provided by the CNH2 organization have been developed through an integrated system of the production of hydrogen from renewable energies, along with the electricity produced from photovoltaic solar energy.

Their process consist of transforming the electricity obtained from renewable energy into hydrogen through an electrolyzer and later stored in hydrogen storage specification bottles. For the application in the HRS, different pressure are assigned for hydrogen storage systems.

For instance, the hydrogen dispenser would take a pressured hydrogen of about 350 bar that is released through a WEH TK17 nozzle. This HR Stations have the capacity of refueling 2 vehicles in a day with a time break of 30 minutes between charges [25].



Figure 6. Real installation of both H2 Storage and the Application of it on Vehicles in Ciudad Real- Spain.

4.1.6. Industrial material handling

Material handling vehicles entail airport towing trucks and forklifts, they are used indoors. With fuel cell applied these vehicles are absolutely almost noise free and definitely zero- emission. The reason behind the popularity of fuel cell powered material handling vehicles over the batter powered is the easiness in refueling instead of recharging and replacing the batteries. This takes a lot less time and for more shifts to be achieved with no stopping/ wasted time. There are even special deals that can be obtained for large scale manufacturers that are willing to buy a whole fleet, the cost can be reduced.

4.2. Electricity generation

Hydrogen can be a source to produce electricity in the form of fuel cells, with the combination of hydrogen and oxygen extracted from the air to release electricity, water, and heat. The best thing about it, is that it requires no fossil fuel for production nor release greenhouse gases.

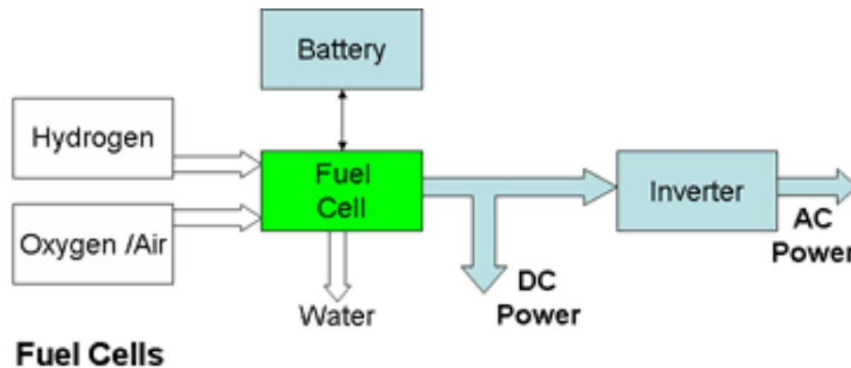

Figure 7. Presents the main components to produce AC or DC electricity.

From the illustration you can see that it may seem like a quite simple procedure, but it is not exactly so. There are a lot of obstacles that have not been yet solved. Fuel cell are clean, produced from renewable energy, and sustainable but they are far from cheap. However, that seems to be a major goal and the next step on the development.

It is also necessary to mention, that fuel cells are not capable of storing energy as in batteries, they only supply electricity as long as the active chemicals run through the electrodes [26]. Fuel cells are much more efficient than a fossil fuels powered power plant such as a thermal one up to 60%, in addition to, little to nothing heat and great-value electricity.

4.3. Hydrogen Fuel Cells Advantages and drawbacks

The advantages of Hydrogen fuel Cells are widely known, here are a few of them [27]:

- Reduction in emission and pollution.
- Highly reliable.
- Reduction of dependency on unsustainable fossil fuel.
- Great-level of energy efficiency [28].
- Flexibility of Energy.
- Safe to use.
- Renewable.

The disadvantages of fuel cells consist of [29]:

- Very Costly.
- Hard to store.
- Very flammable.
- Hard to replace widely used gasoline.

5. THERMAL ENERGY

The definition of thermal energy is the energy conducted from one body to another as the result of the change in temperature between the bodies. There are multiple ways to obtain thermal energy whether from the sun (solar energy) or the heat waste of industrial processes.

Since the new era of clean energy begun, industries have been searching for every new development they could find that would improve on the ones we already have. Even though solar energy is now the world's energy top priority, it is not as efficient since the amount of heat being wasted. From that sense came the thermal energy storage technology as a way to minimize heat waste and maximize efficiency [30].

In this chapter we are going to focus on thermal energy technologies and to simply explain and outline the different categories that resides within this storage technology.

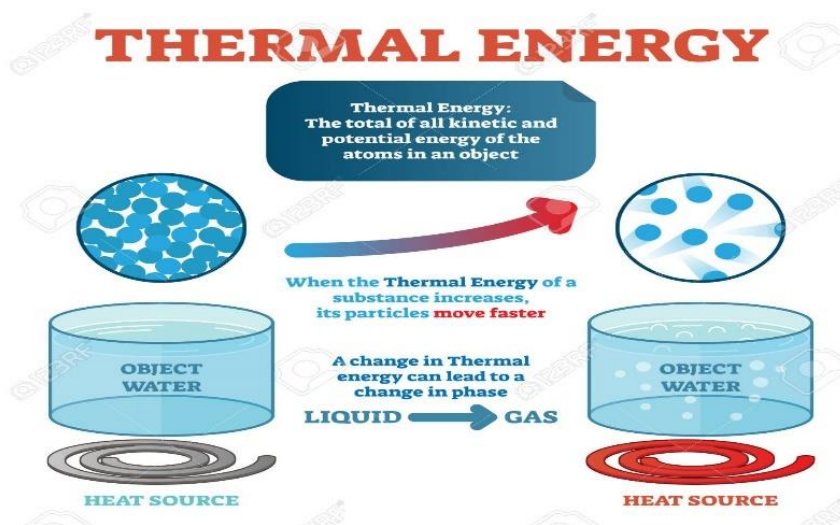

Figure 8. The definition behind the physics of thermal energy [31].

6. THERMAL ENERGY STORAGE (TES)

This is a technology where the thermal energy from the heat and cooling of what could be called a storage medium is stored for a later use at a different time for the same purpose of cooling and heating in addition to energy generation. This kind of thermal storage is commonly used in domestic and non-domestic buildings along with industrial processes. The biggest focus when it comes to TES are the technologies that minimize heat waste and demand yet maximize the heat outcome from solar energy sources [32].

These technologies offer so much to the economics of a society, starting from the reduction of capital costs along with procedures and the cost of maintenance for heat and cooling. By providing average demand instead of cycling demand [33]. It is fair to mention the TES can advance energy efficiency and radically reduce greenhouse gas emission and carbon footprint. TES enhance the increase in the demand management which leads to reduction in costs of life cycle and a steady energy cost providing a potential acceleration in development of time of usage billing and rates.

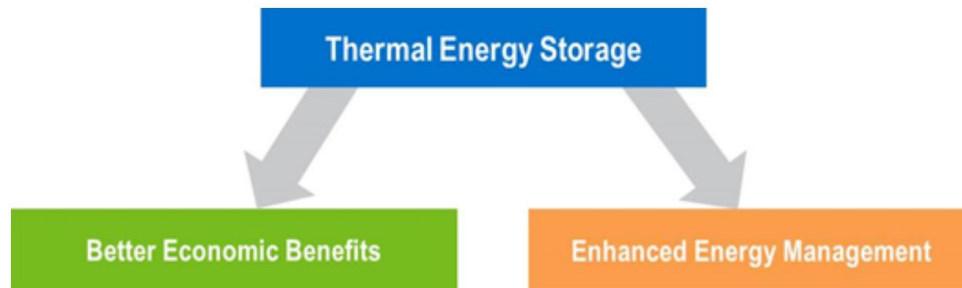

Figure 9. Shows the influence TES has on improving Economy and energy management [33].

TES can improve a system's balance, cohesion and conduct and issues a response by solving any shortcomings between supply and demand, or the inconstancy in temperature of the system. Furthermore, it enhances authenticity, accuracy, sensibility and sustainability of sources of heating and cooling while simultaneously working as an accessory to a battery storage.

6.1. TES Benefits

- It is Cost efficient
- Reduction in operation rates.
- Grid relief.
- Highly capable to recover almost 99% of the stored cooling.
- Fixes the mishaps between demand and supply of energy.
- Enhances system consistency.
- Cost reduction of generation [34].

6.2. Types of TES

There are a 2 main types of thermal energy storage, thermal one which consist of (Sensible heat and Latent heat) and chemical thermal energy storage.

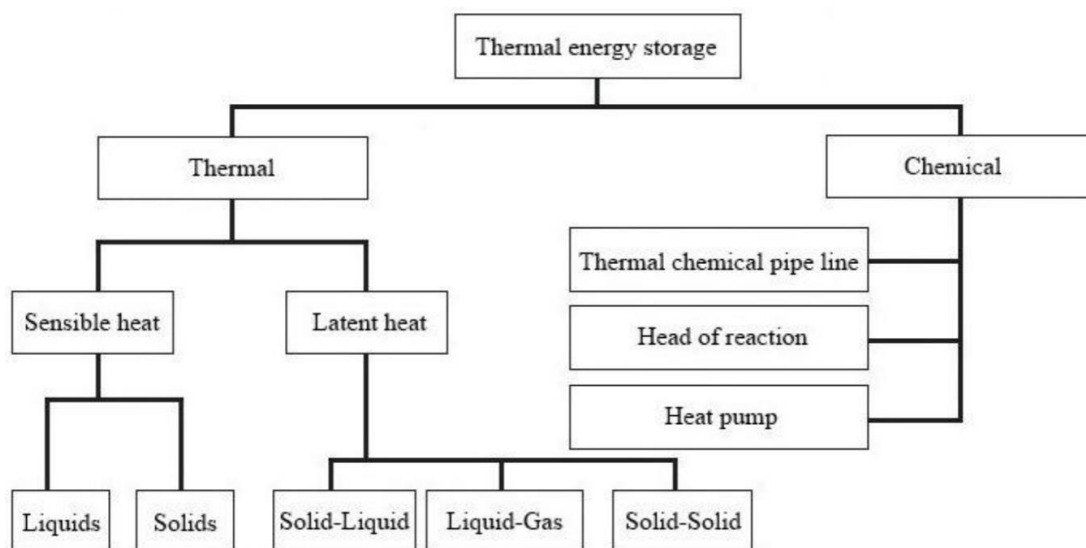

Figure 10. Compiles the types of thermal energy storage.

- 1- Sensible Heat TES: includes borehole, aquifers, electric Storage heaters EST, tanks TTES
- 2- Latent: can offer higher energy densities. Simple, cheap and reliable. Uses phase changing materials PCM (Gas-Liquid, Solid- Gas, Solid-Liquid, Solid-Solid).
- 3- Chemical: uses reaction material to store large high density amount of energy.

6.3. Characteristics of storage system

There are many characteristics that shapes the type of energy storage and describes it the best possible way, among those characteristics are [32]:

- The energy that is stored in the thermal storage system is defined by Capacity. This included the size and the medium of such system.
- How fast the charging and discharging of the energy stored is defined by Power.
- Energy loss that occur during the storage of the energy is defined by the ration Efficiency.
- The time period where energy is stored in the system is defined by Storage Period.
- The time required for charging and discharging is represented by chare /discharge time.
- The capital cost of operations of storage and maintenance of equipment is defined by Cost.

An example of a system that utilizes cooling and heating through the 3 applications of thermal energy storage is using the concentrated solar power. This system combines TTES and EST, PCM. Below is a common example of concentrated solar power where mounted mirrors positioned at a heat collector that would supply steam outcome into a thermal power generation system.

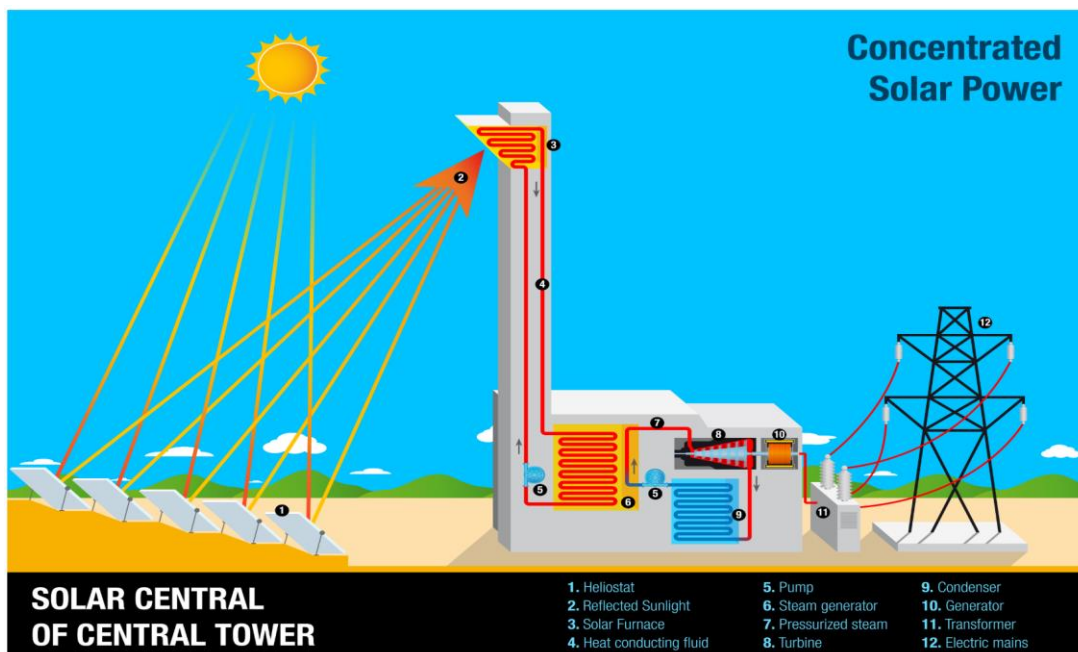

Figure 11. A common example of concentrated solar power generation system [32].

6.4. TES Techniques

There are many thermal energy storage technologies that are quite popular and widely commercialized, some have more benefits than drawbacks and others are still being developed for better outcomes. Here are some examples regarding the primary types of TES [35].

6.4.1 Brick Storage Heater (Electric Storage Heater)

Complete basic electric heater with the exception of being able to store thermal energy amid the night when the level of electricity demand at a low cost and discharges the heat during the day as demanded, therefor called a heat bank. They are usually collected out of clay blocks or ceramic components, and either of water containers or wall made out of concrete. In addition to that iron oxide fillings in the blocks which is known as a heat storage medium. The storage medium can be heated in by switching it on in order to start storing energy through an electric heating element entrenched in the materials.

The heat resulting from storing is released non-stop, and the transfer process can be accelerated through mechanical fans, which most heat storage come outfitted with them, and their purpose is to move and pass air through the heater [36].

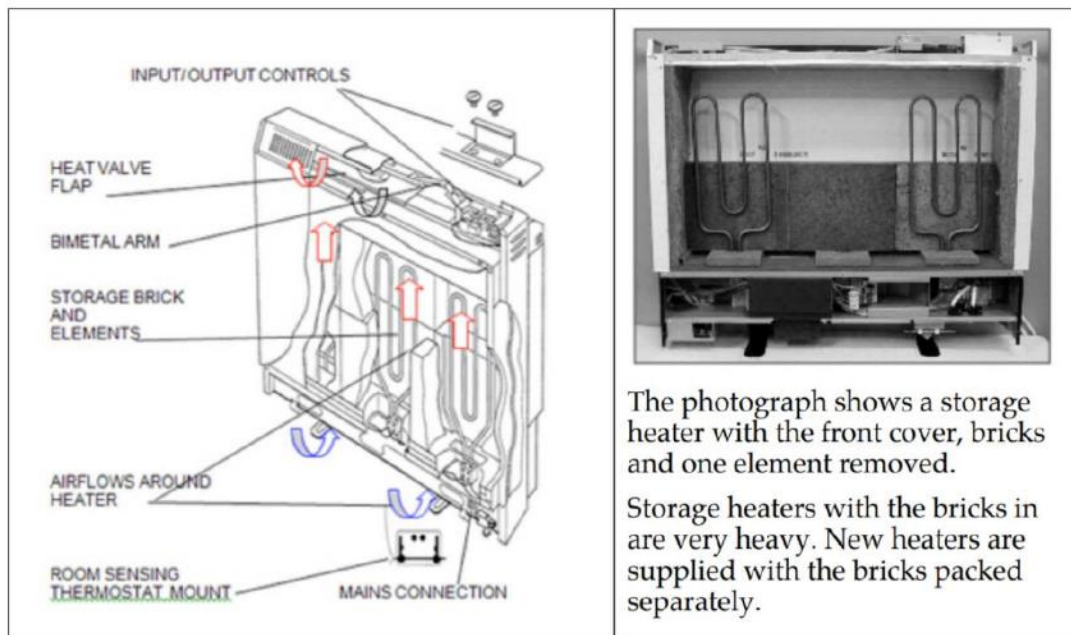

Figure 12. System Schematic of ESH.

6.4.1.1 Storage heater application

Storage heaters have two controllers: the first is input controller (charge controller) this one controls the extent of heat stored, the second is output controller (draught controller) this controls the heat discharge rate. These controllers can be controlled by the consumer or automatically once they are set up to the desired temprature through a thermostat [37].

6.4.1.2 Upsides of ESH

- They are cheaper on the long run than oil based heating systems.
- Allows houses that are based in areas with no natural gas to no pay more on heating electricity bill during the day.
- Installation is much easier than the conventional heaters.
- Almost nothing to zero cost of maintenance.

6.4.1.3 Downsides of ESH

- Heat waste during the night while charging, the room might be warm but that is because of the heat wasted.
- The heat stored overnight will be discharged the next day whether it is needed or not.
- Confusing buttons with no clear instruction for use.
- Due to the materials used to build this type of EHS, they might be very heavy and not easy to move.

6.4.2 Liquid Nitrogen Storage

Liquid nitrogen in a liquid state, at an extreme low temperature is colorless and is stored in specified tanks. Liquid nitrogen is produced by cryogenic or Stirling engine cooler, which liquifies the component of Nitrogen. these coolers can be powered through mechanical work such as wind turbines or hydro power or electricity. It is then stored in insulated vacuum flasks containers such as a thermos. The purpose of these containers is to insulate the liquid from heat completely, any heat in the surrounding environment will cause the liquid to boil and causes it to convert into gaseous state, which means loss of liquid nitrogen storage.

Liquid nitrogen is used as a coolant for air conditioners, refrigerators and electrical cooling such as chips and electric boards in the computer. The basic process is that the consumption of it is boiling the liquid and therefor returning it into the atmosphere as a nitrogen. The production of liquid nitrogen is an accelerated process. Refrigerating plants currently produce over few tons per day of liquid nitrogen, and the excess of this production is used in the production of Liquid Oxygen.

Liquid nitrogen vehicles are supposedly just as Electric cars with the exception of liquid nitrogen being used to store the energy rather than the batteries, although a lot of people have their doubts regarding that comparison [38].

6.4.2.1 Obtaining Liquid Nitrogen

The regular state of nitrogen is normally gaseous, it is hard to distinguish it in the air as it has no distinctive colors or smells, and it is not poisonous. The liquid state on the other hand is extremely poisonous to any living tissues it comes in contact with. To produce liquid nitrogen, it requires air followed by 4 steps of process:

1- Air compression

Since nitrogen is a very cold element, it also has the specificity of its molecules being very far apart, that when they are put under air compression it forces the molecules to be very close and in contact with one another, which causes it to heat up very fast with a high temperature.

2- Cooling

After compression, the gas is then left to cool down and as it does so, it expands. It absorbs the temperature surrounding it. The gas is compressed over and over again until the liquid is produced.

3- Freezing

A cryocooler is a device that can also be used to produce liquid nitrogen under normal atmospheric pressure with no compression. The nitrogen gas is shoved into a container flask and then cooled by the cryocooler until liquid nitrogen is produced.

4- Handling the liquid

Nitrogen in a liquid state has a very low boiling point, it expands at regular room temperature, which might lead to explosions and eventually it being poisonous. Therefore, it should be contained in specific containers or flasks that are equipped to contain and transport liquid nitrogen. There are also gloves made specifically to be worn when handling liquid nitrogen called cryo gloves.

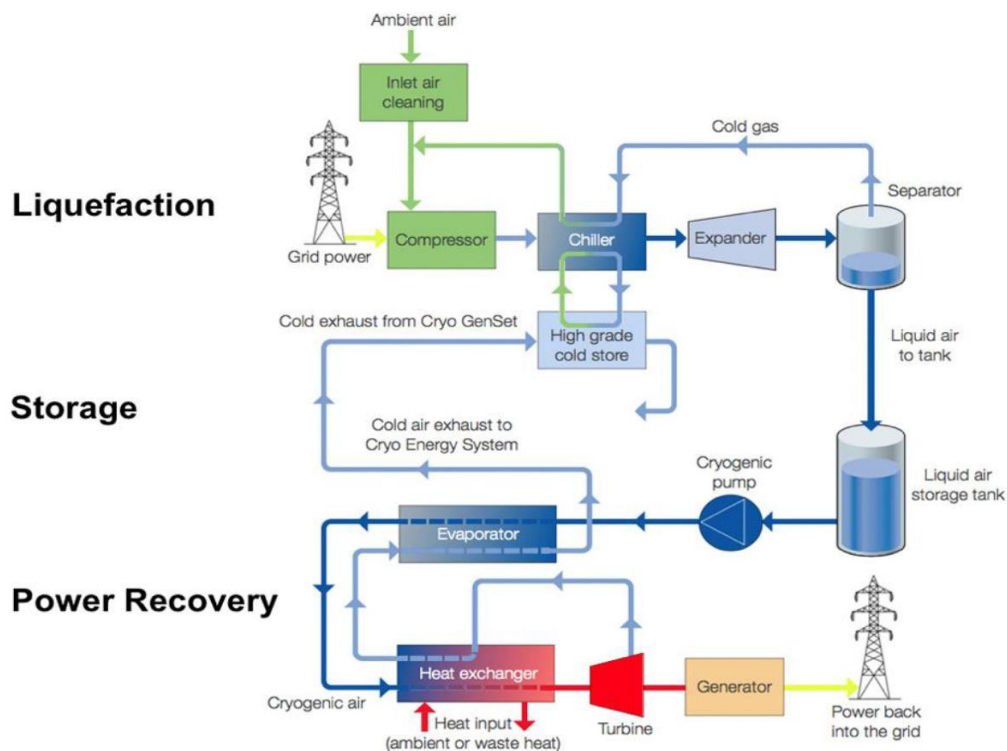

Figure 13. System description of Liquid Nitrogen as a means of storing backup electricity.

6.4.2.2 Tanks Specifications and Transportation

In order to place liquid nitrogen in containers, they need to have certain specifications and safer standards to be met to avoid catastrophic consequences caused by the wrong material used for the pressure-relief of the tank. Materials that are acceptable and preferable combined or each on its own are [39]:

- Steel (Cheap, Strong)
- Carbon Fiber (Strong, Light)
- Kevlar (Heat resistant, High Strength, Steel replacement)
- Aluminum (Reactive, Low density).

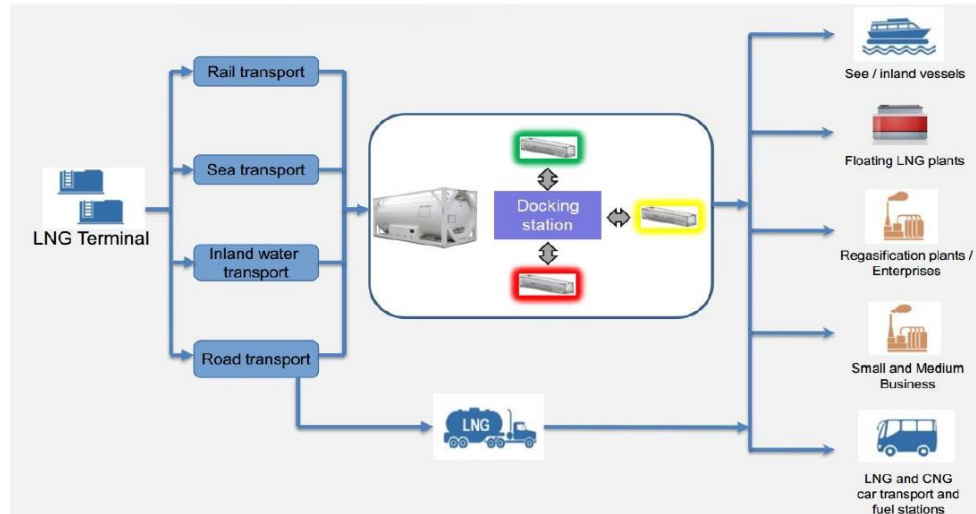

Figure 14. Transportation routes and methods of Liquid Nitrogen.

6.4.2.3 Liquid Nitrogen Vehicles

It is a vehicle powered by cryogenic fluid, aka liquid nitrogen. by using a very cold substance to fire up the engine with useful energy. The engine would contain a pressurized tank about 24 gallons to store the LN. pressurant bottles of N₂ gas a substitute pump. The gas later on pushes the LN out of the tank (flask). Using atmospheric heat, a primary heat exchanger heats LN₂ to create N₂ gas, and that gas is then heated under pressure to near atmospheric temp. a secondary heat exchanger, heats the LN₂ that is coming out of the pressurized tank taking heat from the exhaust [40].

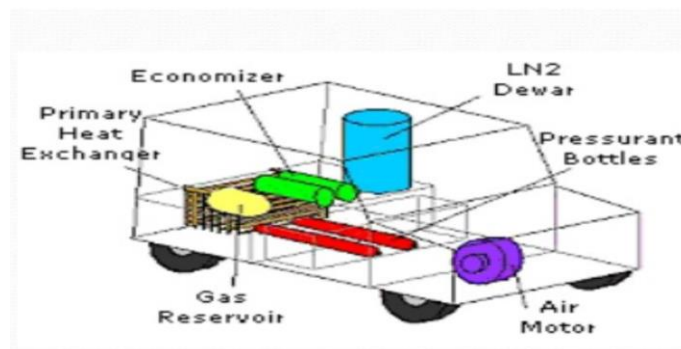

Figure 15. Components of a Nitrogen powered car.

6.4.2.3.1 Real Application of Liquid Nitrogen Vehicles (Cryocar)

The LN2000 aka cool car is a Liquid Nitrogen powered vehicle that was first developed by Abe Hertzberg at the university of Washington (seen in the picture below with one of his students) with the LN2000 that they developed and published it as the car that runs on air. It has a 7 hours power engine, with maximum speed of 40 Km/h. LN2000 could travel 127.58 km with about 90 Liters of LN tank at a speed of 32Kmph [41].



Figure 16. The liquid nitrogen powered Vehicle LN2000 – the car that runs on air.

6.4.2.3.1.1 Advantages of LN2000 after trials

- This car is not toxic, corrosive or Combustible it is simply cold.
- Refilling the tank takes only about 10-15 mins.
- Zero- greenhouse gas emitting.
- No concerning of mis-disposal of the battery.

6.4.2.3.1.2 Disadvantages of LN2000 after trials

- Since the N₂ is a very cold cryo-material passing through the heat exchanger tubes, it results in moisture condensing on top of the tubes thus obstructing the flow of the air.
- Safety issues concerns. What if the LN leaks off it could prove to be fatal and destructive?

6.4.2.4 Benefits of LN powered Vehicles in General

- Reduction of pollution caused by millions of cars all over the planet.
- No need for transportation of fuel since it is powered by the grid. This is also a reduction of cost.
- Low maintenance cost.
- Unlike batteries, liquid nitrogen tanks can be recycled or safely disposed of with no repercussions.
- The time it takes to recharge batteries, is a lot more than refilling a tank.

6.4.2.5 Challenges of LN powered Vehicles

- The losses and inefficiency that occur during the liquification process.
- Any type of energy conversion has limitation and losses
- The unavailability of liquid nitrogen refilling stations for the public use [42].

6.4.3 Molten Salt Energy Storage

It is a sensible heat storage technology, can be used as both a thermal energy storage and a heat transferring fluid [43]. Molten salt based systems have the ability to maintain a reduced sized installation in comparison to other conventional storage systems.

The technology works primarily as a concentrated solar power generation system with mounted mirror on the ground focused on the tower, when the sun hits the mirror it deflects the concentrated solar on to the receiver tower, inside it is the molted salt mainly gathering all the heat to then reroute it a thermal tank for storage [44]. After the electricity is generated, the same hot molten salt is then rerouted to a steam generator. It is also used to generate stem at a high pressure, this steam is used to power a traditional steam turbine. At the end the molten salt is recycled again by sending it to the cold thermal storage tank.

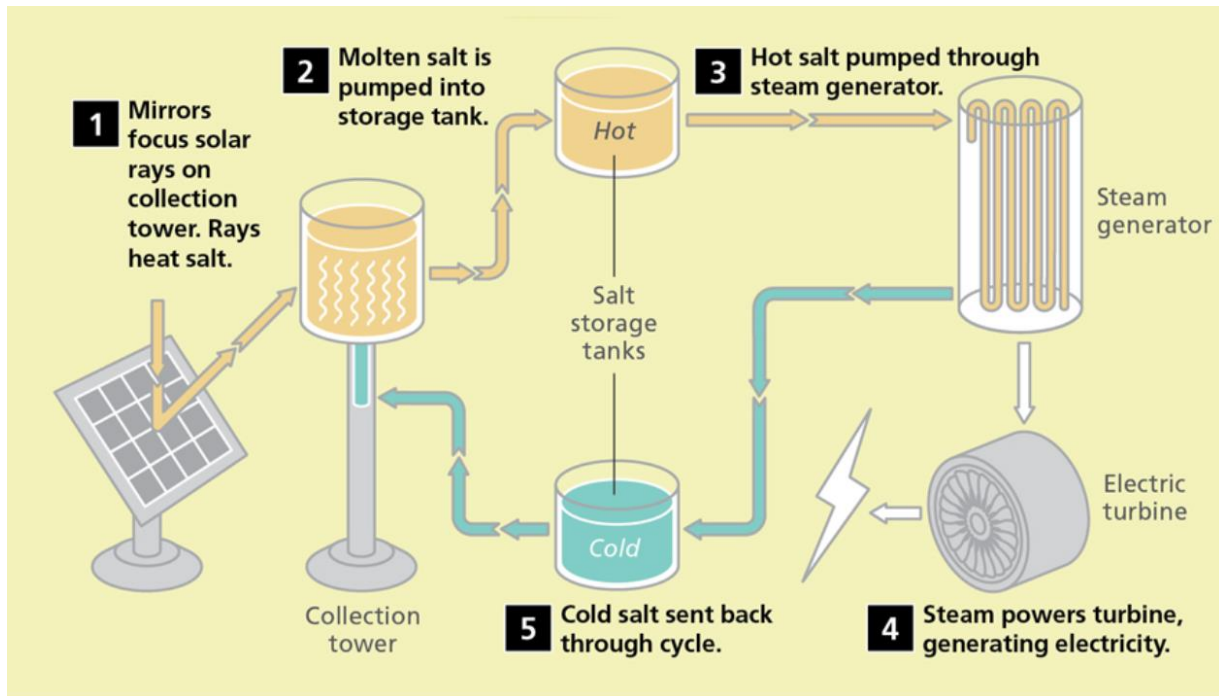

Figure 17. Concentrated Solar Power System with Molten Salt Energy Storage. Source: Jay Smith.

6.4.3.1 Benefits of Molten Salt Energy Storage

- Combined solar thermal power plant with molten salt energy storage can easily operate non-stop whether it is off grid or on grid.
- It has the lowest cost of all other energy storage systems.
- It is a more secure and reliable transmission system.
- Produces twice the amount produced by any other solar technology.

6.4.3.2 Example of Molten Salt Energy Storage

In the year 2017, the Navajo Generating Station was set to be shut down in the year 2019, and officials responsible for it were considering multiple buyers to prevent that from happening. Later that year the U.S. Interior Secretary held a meeting with a company called NantWorks to discuss the possibility of converting the coal-powered plant into a highly concentrated solar plant including the new technology molten salt, a technique which ended up saving the Facility. It is a 110 MW Solar energy power plant. With an electricity production enough to power 75,000 homes in addition to storing energy using the molten salt techniques [45].



Figure 18. The Navajo Generating Station incorporating Molten salt techniques in Southwestern Nevada, USA.

6.4.4 Seasonal Thermal Energy Storage

Seasonal storage is the heat and cold combined over a period of time it could take months, or multiple seasons. By storing heat during the summer and reusing it during the winter to warm up or using ice and cold during winter seasons to cool down during the hot summer seasons, hence the name Seasonal comes from. Seasonal thermal storage are mostly allocated underground which help with energy loss reduction. The medium used for storage are natural geologic such as sand, earth, solid rocks or aquifers [46].



Figure 19. Construction of Seasonal Heat Storage in Munich, 5700 m^3 , 2007.

6.4.5 Aquifers Thermal Energy Storage Systems

Open Systems where ground water would be pumped into the aquifers to be heated up. When hot water is needed it is withdrawn from the aquifers and after it gets cold it is pumped into cold wells.

At the moment, aquifers TES are currently being used to store cold energy during the winter to be used later for cooling during the summer. Usually, the cold stored water is used immediately for cooling. Nevertheless, when there is a pump involved, they can use it for heating as well. The graph below shows the aquifer system [47].

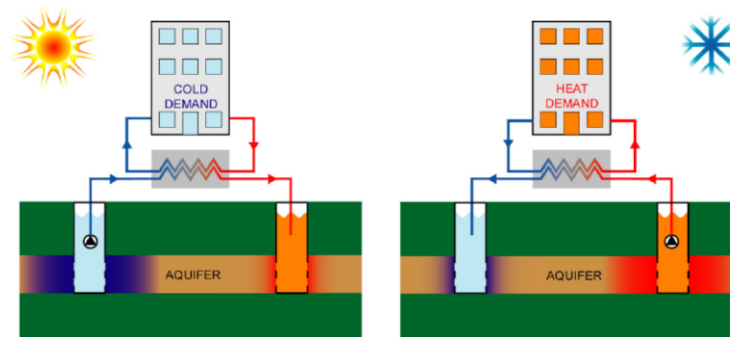

Figure 20. ATES throughout the year.

6.4.5.1 Example of current Aquifer TES installation

- Richard Stockton College- New Jersey, USA

The Project was installed in 2008, equipped with aquifer thermal energy storage. Consisting of 6 wells, aquifers with a depth of (100-200ft), it is used for cooling with about 800 ton of thermal capacity.[48]

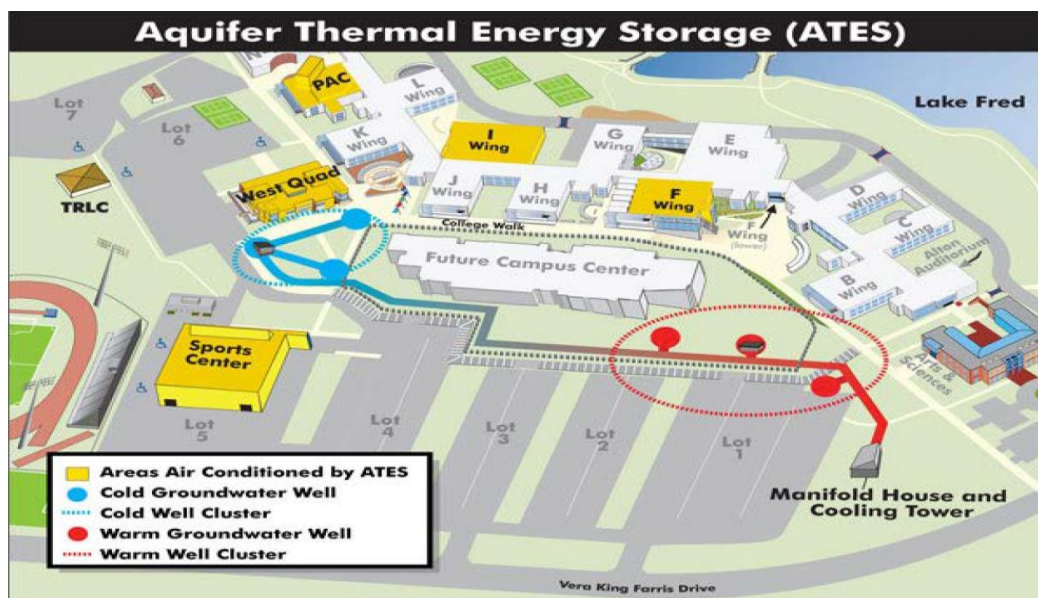

Figure 21. A schematic of the Richard Stockton College aquifer system. New Jersey-USA.

6.5. Thermal Energy Storage obstacles

- Thermal Power Plants cause a lot of exhaust gas that are harmful.
- There are additional costs
- Infrastructure rebuild and change requirements
- Energy Losses [49].

7. COMPRESSED AIR ENERGY STORAGE (CAES)

They are known to be as powerful as pumped hydro power plants, with a lot of similarities such as storage capacity, the output and the applications. The difference is rather than CAES pumping water from a low to a high reservoir, CAES rotating air is compressed in underground storage called cavern, under pressure. When the needed electricity is demanded, the stored air under pressure is heated up and then expanded, therefor generating power.

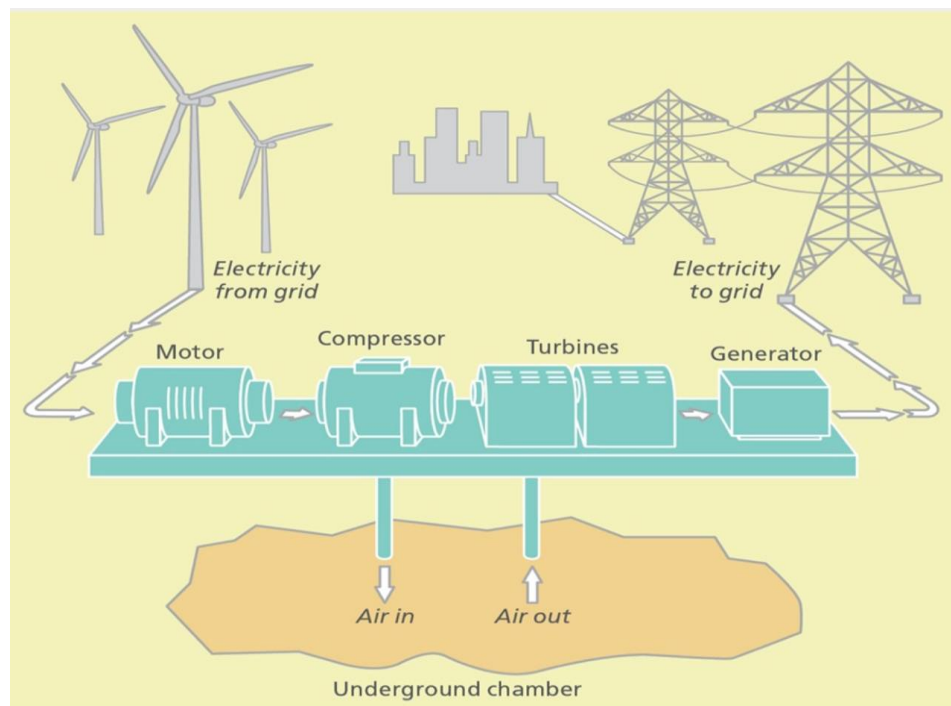

Figure 22. CAES Technology of power production. Source: Jay Smith.

The purpose of CAES technology is when demand is low on energy, the use of motors or engines powered by electricity or even natural gas can be used to compress air and inject it underground in a salt dome in a large empty but controlled space. Later on, that compressed air is heated and expanded to push back a turbine to generated electricity.

7.1. Step by Step

- ✓ The excess electricity or off peak power is used to compress the air.
- ✓ That air is pumped into the underground.
- ✓ When demand is high on electricity, the stored air is then used to run a turbine generator.
- ✓ The electricity produced is then delivered back again to the grid.

7.2. Current Installation of the technology

Since 2012, there are 3 counted large scale facilities for CAES around the world. These there all use the underground cavern energy storage techniques.

- In 1978, Huntorf, Germany was the first facility using this technology. It takes about 2 hours to release all the energy stored from the air and has a capacity of 290 MW [50].
- The second facility for CAES is McIntosh, Alabama completed in 1991. Has a capacity of around 110 MW. This facility can generate electricity at about 26 hour intermissions [50].
- The third CAES facility was developed in 2012, in Gaines, Texas. With the largest capacity of the 3 facilities at about 500 MW [51].
- Currently, there is a world's first CAES facility that is under construction since approval in 2013, that does not require additional fuels for the production of demanded heat. This facility hopes to convert and store energy with an efficiency of 70% or higher [52].

7.3. Storage locations

This kind of technology requires large spaces due to the low density of the storage. The best location for CAES are synthetically formed salt domes in very deep underground salt construction. The reason why this technology opts for salt caverns for the unique features that they offer. They have zero losses of pressure, highly flexible, there are absolutely no reaction caused by the salt rocks in the dome or the oxygen surroundings. In the case these salt caverns are nowhere to be found or constructed then the next best thing are the aquifers, but this is only possible after several tests have to be conducted to determine if the oxygen would react to rocks or with any organism that might be in the aquifer rock composition. Otherwise, this would completely ruin the storage and cause it to leak and tear [53].

7.4. Reasons for CAES application

- Price Fixing and trading
- Balancing the supply and demand on electricity
- Improving functioning efficiency
- Greater use of renewable energy in power generation.

CAES has been used in many cities all over the world it has been considered as an alternative for the hydro power plants. It is comparatively cheap, plus it involves only natural materials with no toxicity. The only downside is that it requires a salt dome (cavern) or any similar space.

7.5. The Future of CAES Technology

Currently in the UK, a professor at the university of Nottingham, Seamus Garvey is researching the use of energy bags residing in the deep ocean in order to accomplish the task done by the natural cavities that are used today. The idea is to have the deep water do the work by working as a pressure vessel, however, the energy remains the same no matter how stocked these energy bags become. The professor speculates with this technology the energy storage cost per unit would center around £1-£10/KWh, which comparatively cheaper than other commonly used technologies. It is predicted that with this technology applied, by the year 2020 the UK would be able to store 200GWh of electricity, which would help the grid become more independent from conventional energy sources and dependent on renewable energy

sources. With this CAES technology the UK is 1 step closer to achieving goals towards their green energy storage targets [54].

8. HIGH-SPEED FLYWHEEL

Flywheels are mechanical devices that are made specifically to store rotational energy, it has the ability to resist changes in analytical speed by movement of inertia. The electric energy is stored in a form of kinetic energy. The rotational motion (rotor) is the kinetic energy in this case. This technology is only a short-term energy storage as a back-up energy when required due to the fluctuation or loss in power. The movement of the inertia permits the rotor to keep on spinning frictionless rotations, therefor resulting in kinetic energy generating electricity from then. In the case of low demand, the electricity is centered towards the rotor that leads to an acceleration in the rotation motion of the cylinder inside the vacuum airtight case. When the demand of electricity is high, that kinetic energy is turned back to electricity [55].

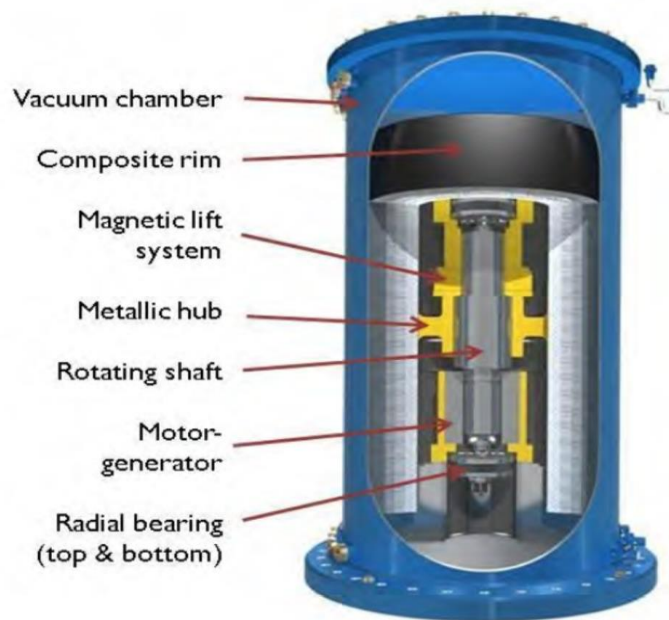

Figure 23. Flywheel power storage technology.

Flywheel are best known for applications of high power, lower energy that necessitate many cycles. Flywheel feature high density of energy and a serious endurance which permits them to repeatedly cycled without any effect on their performance. Not to mention their rapid response rates, they are capable of charging fully and discharging in a matter of seconds or even less.

8.1. Applications

Flywheel are notably fitted for many applications, entailing system reliability, long term backup, power quality and space regulations. They can also be implemented in hybrid-vehicles that tend to start and stop frequently [55].

The best thing about flywheels is the response time is immediate for energy charging needs. The only con is that it is a very short term energy storage with only storage limit of about 15 minutes only just enough for short quick bursts.

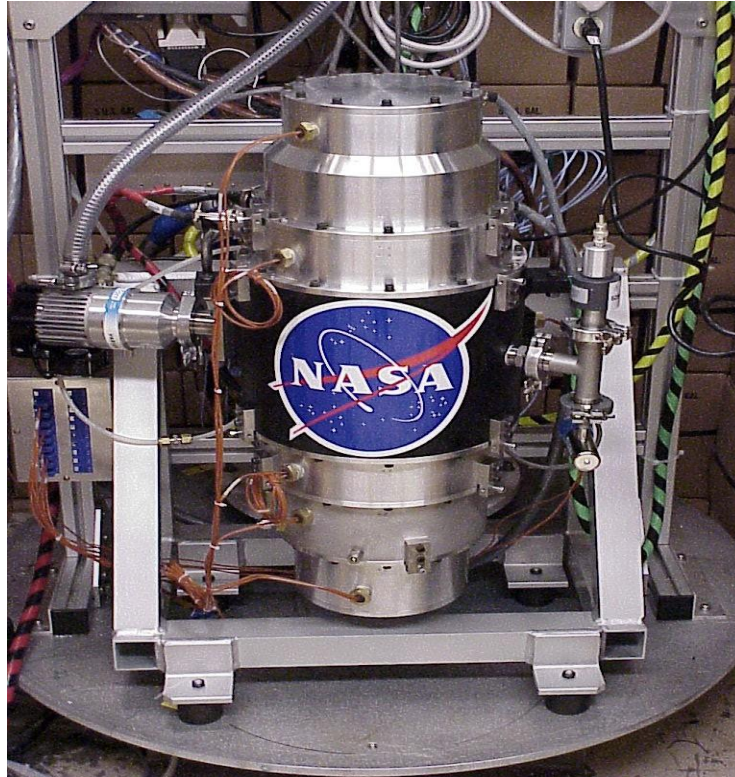

Figure 24. NASA G2 Flywheel.

8.2. Advantages and Disadvantages of Flywheel Electrical energy storage

Advantages	Disadvantages
Power and energy are nearly independent	Complexity of durable and low loss bearings
Fast power response	Mechanical stress and fatigue limits
Potentially high specific energy	Material limits at around 700M/sec tip speed
High cycle and calendar life	Potentially hazardous failure modes
Relatively high round-trip efficiency	Relatively high parasitic and intrinsic losses
Short recharge time	Short discharge times

Table 2. Pros and Cons of the technology.

8.3. Future of Flywheel Technology

There are new products being developed every day for this growing technology and due to shining advantages, that it promises. Therefore, there are new applications being proposed now with the flywheel technology incorporated in it as the storage medium. These applications include among them voltage regulation, inrush control and stabilization for microturbine and wind generation. However, the most demanded and sought out application nationally and internationally regarding this technology is power quality (PQ).

Currently, flywheel is being commercialized as reliable, safe, environmentally pro and an alternative for batteries and power conditioning tools due to the high-cycle life and uninterrupted power supplies, which will lead the industry and the sector to a grand improvement [56].

9. PUMPED HYDROELECTRIC ENERGY STORAGE

Pumped hydro storage technology consist of two water reservoir the lower reservoir pumps water into the upper water reservoir. When energy is required the water in the upper reservoir is released to push through the turbines and therefor generating electricity. Pumped hydro is quite popular and used massively in the energy storage industry, at around 95% of that stored energy comes from pumped hydro [57].

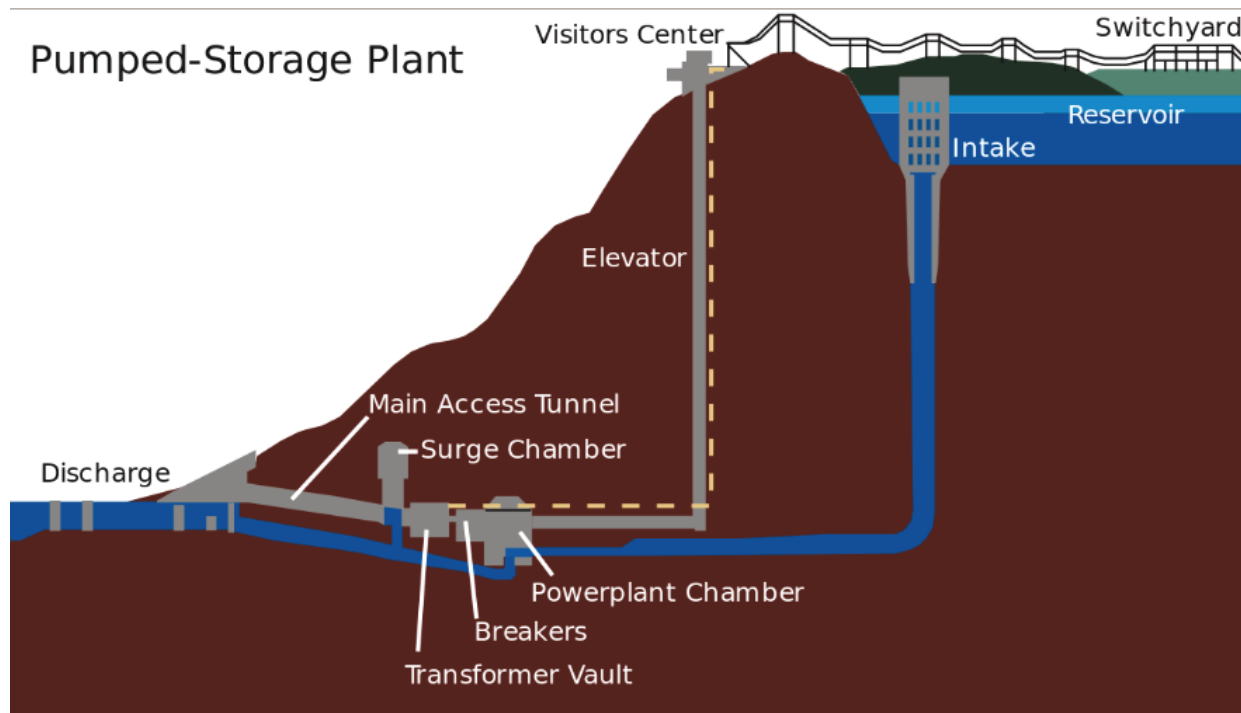

Figure 25. Pumped Hydroelectric Energy Storage.

9.1. Reasons behind pumped Hydro Storage

This technology has the ability to establish stability, balancing energy, high capacity of storage, and grid frequency control. It also has very fast response to very high load changes in a matter of seconds. Currently, a pump hydro storage can normally store hydraulic reserves storage up to 6-20 hours. The next working step is to increase the size of the plant and the number of units. When increasing the value of the hydroelectric pumped storage, we can concentrate it and configure it to match the highest of demand. During the testing and application of pumped hydro the result showed that the technology has a very high speed response to frequency anomaly just as fast as the conventional hydro plant, therefore it enables it an extra stability and balance to the system and grid [58].

9.2. Pumped Hydro- Storage discussion

The typical lifespan of a pumped hydro storage can last up to 50 years. The great news is that currently it has been discovered by scientists over 530,000 location all over the world that is suited for pumped hydro energy storage technology, that is able to store energy sufficient for the entire planet. So far, these locations have only been allocated by an algorithm, which means on ground tests and research have to be done. But it is only fair to mention that it was previously known that there are not any more suitable location for the pumped hydro storage technology and that it wouldn't be enough to store energy for the whole planet in case of high energy demand, but according to this discovery this proves otherwise. With this number of locations the estimation for potential energy storage would peak around 22 million GWh [59]. A single pumped hydro can store about 10,000 MWh of energy in a reservoir of a size of 1Km diameter into 25m deep, this installation can last for about 50 years minimum.

9.3. Example of applied Pumped hydroelectric energy storage

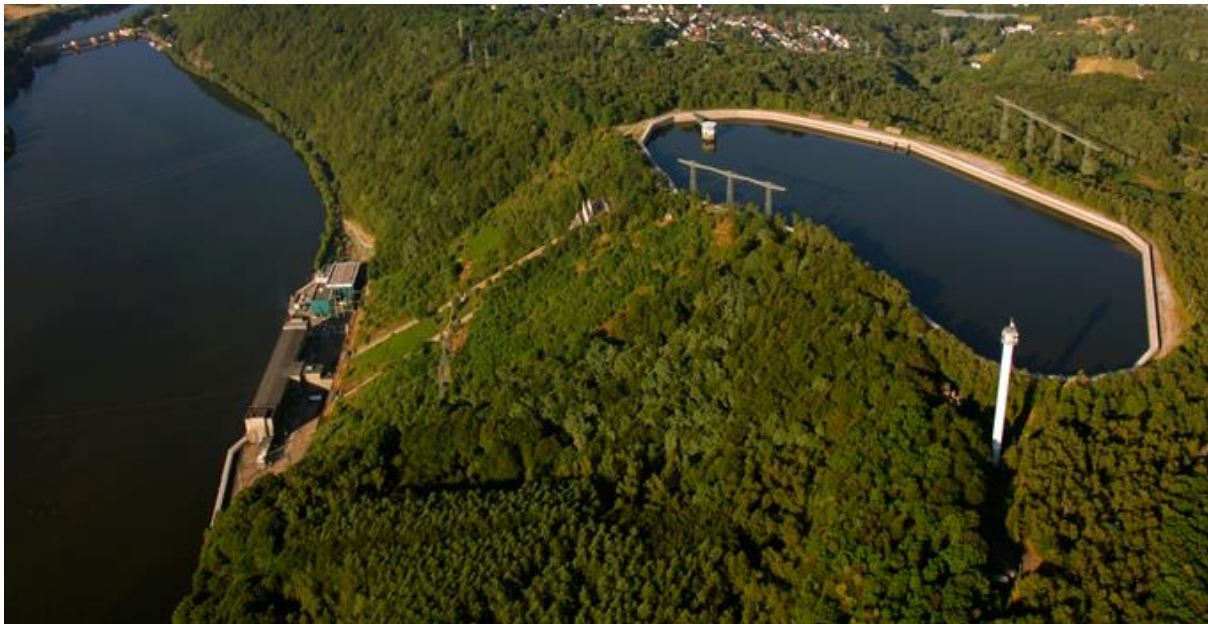

Figure 26. Genex Power's Kidston pumped hydro storage located in North Queensland, Australia.

There are only 3 hydro projects in Australia even though the amount of success that comes from this technology. There are available sites but none have yet been poached [60].

10. RAIL ENERGY STORAGE

The principle of this technology is simply dependent on the gravitational pull, using something that is always to provide something that we must have. Since we have a slight instability with wind and solar energy, for the unpredictability of the weather or the constant changes, the constant search for new clean technologies to store energy is a non-stop. Lately, scientists have figured a way to use gravity into our advantage in the field of energy storage. Now as we discussed earlier flywheels, hydroelectric and later on batteries as means of energy storage, the search continue for something as reliable but even cheaper.

The solution to that came in the vision of old used up trains, to run them up and down from a height. The idea is to harness whatever power along with the kinetic energy that comes from this technology into

utilizing it and adding it to the grid to be used as and when demanded. This technology is completely green, it's based on the use of other renewable energy resources to generate energy enough to power this technology into generating even more energy.

For instance, when a wind or solar farm is generating excess energy than demanded, this energy is directed to a close by facility where the Rail technology can be powered and performed with that extra energy. In the case of low energy production, and high demand on the grid, the energy produced by the railway cars is transported back to feed the grid [61]. The figures below demonstrates the technology applied in the California deserts where it requires empty grounds for the rails to go around uninterrupted and the latter explains the schematic of the technology.



Figure 27. RES project demonstration in Tehachapi, California.

10.1. Technology behind the application

The idea is derived from the pumped hydro technology using the water from one lower reservoir into another higher reservoir. The same concept is used with the exception of water being the pipes and the dam being the rails. The rail cars are rolled back to the bottom of a hill, with the use of excess renewable wind energy they are pushed to the top of the hill, to generate energy the train cars filled with rocks and dirt are rolled down hill and with that creating electricity through the kinetic energy and the braking of the rolling down train cars creates the excess energy we seek to send to the grid.

This technology is considered valuable for the lack of usage of water or fossil fuels or any emitting materials, no chemicals, no environmentally risky materials. completely clean. It also does not require high-tech materials to be applied, it is literally pushing rocks and dirt up and down a hill. Not to mention that building a loop of railroad tracks is much simpler and cheaper than maintaining a big farm battery. The site can easily be cleaned and restored in a matter of months not years.

The efficiency rate of this technology scores at about 80% rate, which translates to that the rolled down train cars can produce an output of 80% of the energy that was given to the cars in order to get them up the hill. It is fair to mention that pumped hydroelectric has an efficiency of a 60 %, which means that this technology is way better. Although batteries have a higher efficiency over time their capacity degrades.

The pros: this technology is capable of bursting big amounts of energy rapidly. It has been tested and proven to work efficiently, currently there are plans for the construction and development of rails that would store 50 -MW of energy in Nevada and it is connected to the California grid.

The cons: it requires a lot of space and empty areas to set up the rails plus the hill, so it would only be applicable in remote areas.

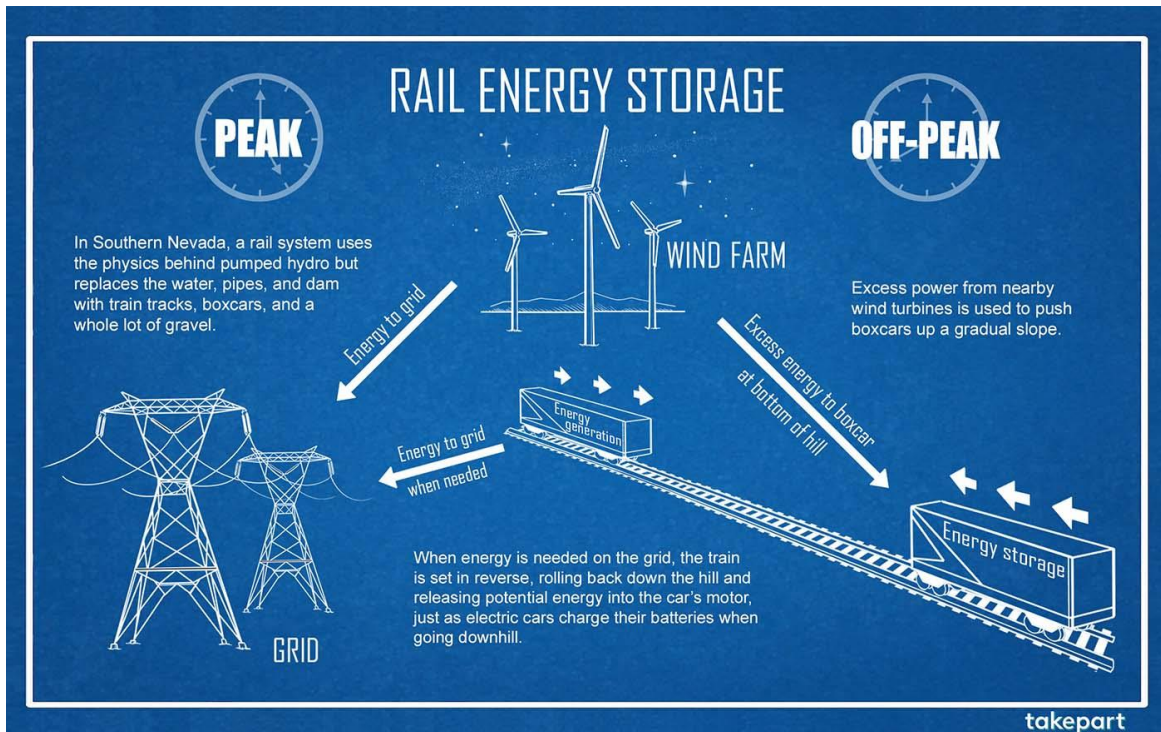

Figure 28. Rail Energy Storage Technology.

11. SOLID ELECTROCHEMICAL BATTERIES

The first battery was developed in 1800, and from then the field of energy storage and electrochemistry started to shine. Battery is basically a device that consists of stored chemical energy that is converted into electricity through one or more electrochemical cells. Each one of these cells has a positive terminal and a negative one. The positive side is the cathode and the negative is the anode. Current flows out of the battery through electrolytes since they permit ions to pass between terminals and electrodes. Therefore a battery can perform what is required.

Nowadays, science and technology have allowed batteries to develop and improve to the point that they are being so reliable for our daily needs and most important devices' needs. The price has fallen down radically than before, and continuous improvement are scheduled. Current development even showed more advances in the technology and we have seen different technologies coming to light, such as the electrochemical capacitors that are rechargeable instantly and the same time, with unlimited and functioning lifespan [62].

11.1. Work process

As we have established, batteries have 3 parts: Cathode, anode, electrolyte. The battery is able to work when the charged ions travel to the anode from the cathode by passing within the electrolyte. This is a result of a chemical reaction between the battery's components which conveys electrons. That would later lead to a positive build up on the cathode that would immediately attract the anode's negative

electrons. The constant movement of electrons from anode to cathode cause the generation of power to the connected device

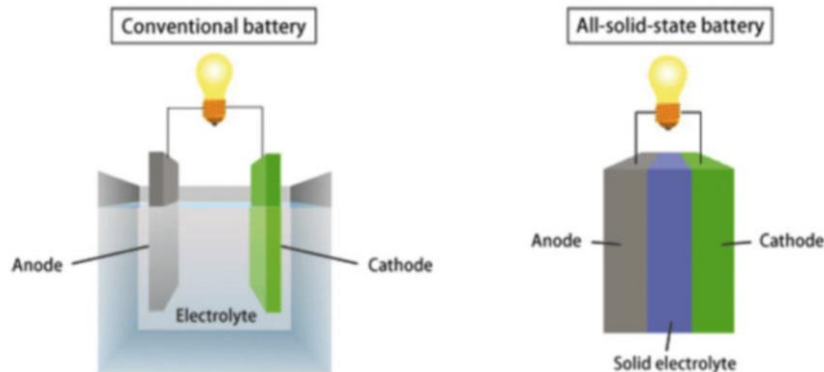

Figure 29. Illustration of a conventional battery & a solid-state battery.

11.2. Comparison between regular batteries and Solid State batteries (SSB)

The difference between a solid-state battery (SSB) and a lithium-ion is that the latter uses liquid electrolyte, meanwhile SS batteries use solid electrolyte. This change happened to improve the performance and the quality of the battery. With that advancement, SS Batteries are so well equipped for our needs, they have a lower environmental impact, weigh less, unlike regular batteries they are a less fire hazard, in addition to have more power to offer.

Unfortunately, there is a downside, these batteries are cost effective, and manufacturer are still trying to figure out a way to make it cheaper. Fortunately, with the scale of advancement the field of batteries are going, we should expect to hear great news regarding these issues soon enough.

11.3. Application of SSB

By using SSB you can improve and extend the life of any device you are using. They even work best on electrical cars; the manufacturers of electric cars find it very appealing including Tesla where they focus on the battery then move out to the rest of the car. It is considered to be the most important part of the electric vehicle and center of the project. The analysts and scientists predict that the not so long from now the world will witness a transformation in the transportation industry, especially when the they fix the distance between each charging station and increase the availability and widespread [63].

11.4. The Future Application of SSB

There is a new solid state battery that is taking the world by a storm, the battery was developed by a team of professors and engineers working in the University of Texas, the products has no toxic liquidity that is normally shown in previous generation of batteries. The batter is also long lasting, rechargeable and applicable for mobiles, energy storage and electric cars.

Their aim was to develop an innovation that is cheaper, with a longer lifespan. The battery is in a solid state lacking any liquid contents which makes it higher density therefore, it can mean that an electric car would be able to drive it for more mileage [64].



Figure 30. The futuristic Solid State batteries with breakthrough development technology for energy storage.

12. FLOW BATTERIES ENERGY STORAGE

They are very similar in functionality with the SSB, though they have exceptionally bigger capacity to store more energy. The reason they are capable of doing so is due to the big tanks that is attached to the chamber where all the electrochemical reactions take place. These tanks are responsible of holding the charged liquids. Each tank is holding charged liquid from each terminal positive and negative.

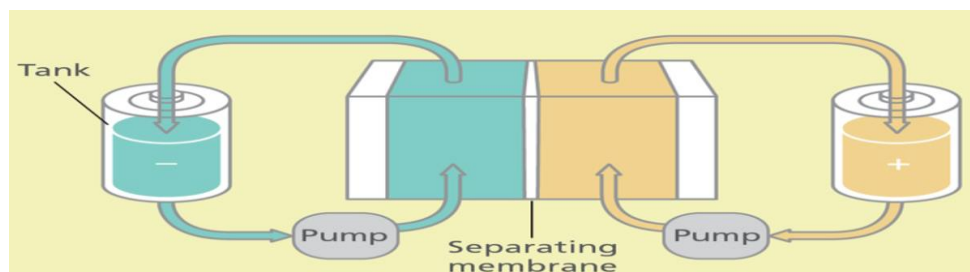

Figure 31. Flow batteries illustration. Source: Jay Smith.

12.1. Flow batteries Discussion

Flow batteries have many advantages to its peers, they are abnormally fast with instant recharge through the replacement of liquid electrolyte, while at the same time retrieving the used material towards reenergizing. In addition to that, enormous quantity of electricity can be released promptly. The unfortunate downfall of this is that it requires space to be able to store those big tanks filled with liquid. There is quite the risk of resulting in pollution caused by any of these tanks leaking, also this technology can be deemed unreliable at times [65].

12.2. Redox Flow Battery

Rechargeable batteries where the tanks (electrolyte) holding dissolved electroactive categories flows within an electrochemical during charge converts the electricity into chemical energy. The energy stored in the tank until demanded when it is pumped back during discharge where the energy is converted back from chemical into electrical [66].



Figure 32. Redox Flow Batteries. Lancaster, NY.

13.2.1 Advantages

- Highly efficient conversion between the chemical and electrical energy.
- Very Quick Response time, and long lifespan.
- High capacity for energy storage up to hundreds of MWh.

13.2.2 Applications of Technology

- Can be used to store energy achieved from renewable resources, to be supplied later during low generation.
- Able to provide power when main power supply fails.
- capability of stabilizing frequency and Voltage support.
- Storing energy during low demand and providing it during high demand.

13. SUPERCONDUCTING MAGNETIC ENERGY STORAGE (SMES)

SMES is a technology based on storing electricity obtained from the grid inside the coil's magnetic field which consist of zero to nothing energy loss superconducting wire. Since this technology stores electricity directly from the grid it allows a rapid delivery of highly efficient high power [67]. SMES is considered to be a device that is grid-enabling which stores and releases considerable amount of power instantly. This system has the capability of discharging high quantities of power within a small portion of a cycle to recover the loss or drop in the power line. Critical placement of short bursts of energy can have a tremendous effect in maintaining reliability of the grid and stability more so now than ever before due to the constant rising in implementation of renewable energy resources and the recurring jamming of the power lines [68].

A regular SMES typically subsists of two parts; cryostat superconducting coil and power switching conditioning equipment system. These parts have no motion which indicates higher reliability. When the coil is charged, the magnetic energy could be stored flawlessly indefinitely.

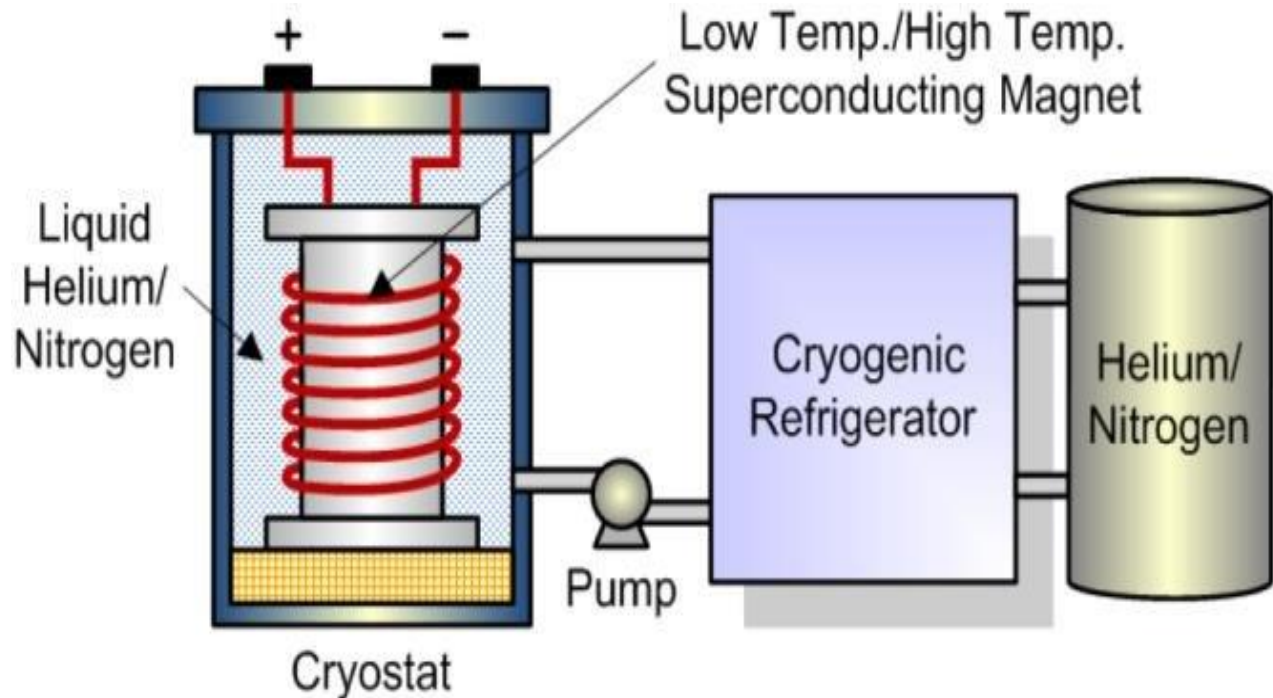

Figure 33. Superconducting Magnetic Energy Storage (SMES) Schematic design.

13.1. Advantages of SMES

- Improves the performance and capacity of transmission line.
- Everlasting cycling capability.
- 100% recovery rate of energy.
- Enhances leveling of loads between transmission line and renewable energy resources and the network of distribution.
- Environmentally friendly free from impacts unlike chemical energy in batteries SMES doesn't depend on chemical reaction therefore it does not contain acids or produce toxins as a result.

13.2. Purpose and Applicability

SMES units can be applied both short-term in a manner of seconds or long-term as in hours storages by helping to level the load on the grid that is being fueled by renewable energy sources. SMES exceeds the efficiency requirements by achieving 85%, therefore SMES can be used to for either or both energy storage and dynamic rectification due to the flash instant response of the Super coil [69].

Application	Micro SMES for power quality	Distributed SMES for system stability	SMES for load levelling
Status	Commercial: several units installed	Demonstration	Theoretical
Lessons learned	Critical issues in terms of the power output and response time.	Additional information is required.	Long-term development and societal commitment is required for large systems that cost over a billion dollars and take more than ten years to complete.
Major development trends	American Superconductor has several units in the field at this time.	American Superconductor is prepared to deliver additional units and is actively searching for customers	None
Unresolved issues	Costs of SMES units	Cost effectiveness of this application compared to other solutions.	Costs, and costs compared to other load leveling technologies

Table 3. Indicates the technology Status belonging to SMES. Source: www.epri.com,2002

13.3. SMES Project Example

In any large scale project requiring constant availability of electricity delivered in a sufficient short period of time is a challenge. Designed power will be around tens of gigawatts to be delivered in just a few seconds, with a maximum value of about 100 GW in just a manner of seconds. These values are not represented today and cannot be provided by conventional power plants. The solution sparked with superconducting magnetic energy storage. The principle was, in a cyclic-shaped superconductor, through a superconductivity flows an electric current to be stored without losses. It was determined the efficiency of SMES is one of the highest in the energy storage tanks that any other technology can provide, almost 95% of the input energy is retrieved back to the grid and any losses occur is due to the conversion of AC/DC current loads [70].

One of the world's largest SMES commercially used with 10 MW magnetic storage tanks is installed in a Sharp LCD TV factory in Kameyama, Japan. It is generally used for storing energy that is obtained by solar cells energy, which is used in the factory as one of the energy sources. Since, SMES does not store energy in chemical reaction, rather in a magnetic field which allows it to have high efficiency, for instance significantly higher than pumped hydro storage. In addition to that, it has the capability of unlimited storage and the amount of charge and discharge plus the flexibility to construct and cheap prices makes it a very promising storage technology [71].



Figure 34. One of the world's largest SMES magnetic storage tanks in Kameyama, Japan.

14. RISK ASSESSMENT OF ENERGY STORAGE

When planning to develop an energy storage system there are some risks that need to be assessed and taken into account:

- **Construction Liabilities:** for development of large scale projects, the risk of construction has to be considered and the possibilities of wrong outcome. The connection between solar farms to the batteries and to the grid. The space and time frame of work has to fit on a timely schedule. Although things might not work efficiently from the get-go but there is always room for improvement, which is why future changes has to be taken into account during the construction phase.
- **Planning Liabilities:** energy storage varies in size, shapes and outcome. When planning, always keep in mind that rules and regulation change from zone to zone, state and countries. They are different from one another and safety hazards as well. Some building materials are prohibited in one area and allowed in the next. Planning require vast knowledge of everything related to the project whether it be little or big.
- **Technology Liabilities:** any new technology is bound to fail at first. However, that does not make it a failure just simply imperfect. Energy storage technologies require patience and trials, it doesn't always come from the first time, but eventually it does work wonderfully.
- **In-charge liabilities:** there are a lot of territorial issues that appear during the development of an energy storage system. It is a huge deal and that's why a lot of hands are involved, and ownership and leadership go head to head at some point which causes a halt to the work and may cause delay or worse cancellation of the project. Before the start of work, a lot of roles have to marked and highlighted for a better flow of work [72].

15. ENERGY STORAGE MARKET

Although, the market seem to have challenges and obstacles on its way, but it doesn't seem to be affected badly at all. In fact, the market seems to be booming. There is a noticeable growth that is being recorded at the moment and it looks explosive. There are new developments rapidly arising and the costs are dropping at about 74% and are expected to keep dropping steadily 8% each year even through the coming 2020s.

The investment rate is expected to rise up to \$620 billion by the year 2040. The top countries are china and the states and some other 7 countries. The market is expecting enormous increase in growth at about 9 times by 2022 its actual size currently. This include increasing in jobs at a humungous rate of 235% from 1 year between 2015 and 2016 due to energy storage and at 859% increase of jobs by the year 2022 [73].

15.1. Reasons behind the growth

Since organizations such as Tesla, Lockheed Martin and GE are dominating the industry, they have poured hundreds of millions of dollars into research, development, cheaper costs and commercialization.

As a result of that, the costs have dropped rapidly that it convinced so many other companies and in different sectors to make the switch towards renewable energy combined with energy storage since it is way cheaper than building a natural gas power plant.

The most noticeable price drop occurred between 2014 and 2015, where the prices of lithium-ion storages fell down 29%, only to fall 26% the next year, and continued to fall additional 12%. It is now firmly predicted to fall down to 36% by the year 2022 [73].

15.2 Current Development of novel technologies

15.2.1 VEHICLE-TO-GRID (V2G)

Normally, most electric car drive for an hour and then stand still for about 23 hours of the day. What if this time where to be used in a productive manner. By using the car temporarily as a stationary storage. The idea is to use the energy stored in the electric car by returning it back to the grid when the demand on energy is high without taking away from the car any of its advantages, better yet lower the maintenance and purchasing cost. The vision behind V2G does not stop there it actually evolve to Vehicle-to-Home (V2H), by supplying your home with power and earning money doing so.

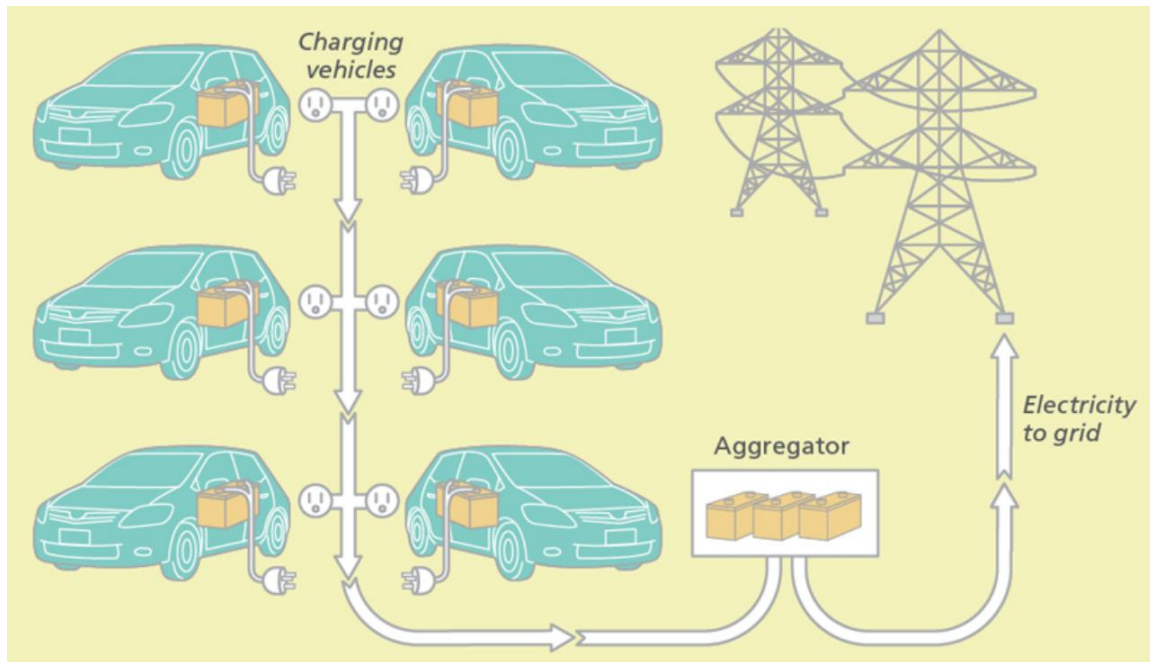

Figure 35. V2G Diagram of the application of the technology. Source: Jay Smith.

15.2.1.1 V2G Application

The battery capacity in an electric car allows it to have the versatility to supply a grid or a home when in demand without coming close to draining it. According to the Mobility house technology they have tested out the electric car on supplying power to a coffee maker for over 50 employees, where one charge of that electric car supplied 1 thousand cup of coffee and that barely put a dent on that car's battery [74].



Figure 36. Nissan Car with the demonstration of the technology V2G in Germany. Source: Nissan.

Nissan in Germany has already published the technology out for distribution for this year and the next one and has already sold over 370,000 vehicles. The vehicle is called EV and it has a 40-KWh battery that works as well as a power station feeding energy back to the grid. During the time where the car is idle for many hours during the day, it can be connected to the grid and used to provide extra services to the grid [75].

15.2.1.2 Electric Car is the connection

With this technology electric cars become the center of all things, in a manner of speaking. Let's say, when we have extra energy that exceeds the demand, then we have electricity that is cheap. Whatever energy we obtain whether it is from the wind or the water or the sun can be stored in the electric car's battery with a very low price, when you charge it at the station. When the demand happens to become higher, the energy in the car can then be returned to the grid for a profit. This technology is evolving by day, soon enough there will be a deterministic time for how long the car is going to be available to storage and when is it needed to be fully charged for long trips. The pros for this technology is that you can use it anywhere as long as there is a plug outlet. The car owners will receive payment for the energy they deposit to the grid with whatever company they choose for the technology with a net measuring policy. The cons from this is that the continuous charging and discharging would cause the car batteries to wear out eventually. Supplying power to the grid could take a toll on the batteries and draining them, which means the owner would have to recharge it before using it.

15.2.2 V2H Applications

Recent complaints from renewable energy homeowners regarding supplying solar power to the grid for low cost yet, having to buy it back for a higher price rose to the surface and became quite deafening. But electric car companies have heard the call including the mobility house and they have announced their solution for this issue. Their approach was focused on storing the energy to be used later on your own demands. Since the capacity on modern electric cars are way more sufficient that we expect, they can easily supply a single household with electricity for many days. And that is basically the simple yet great idea behind V2H technologies [74].

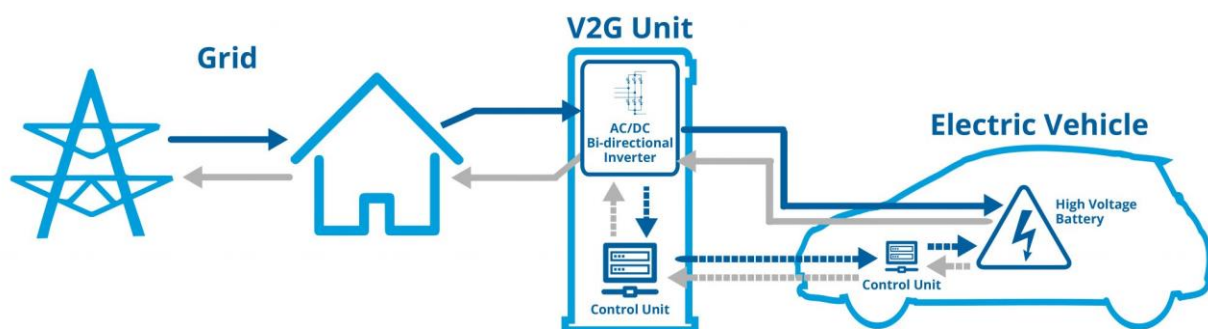

Figure 37. V2G and V2H illustration.



Figure 38. The V2H Technology applied [76].

16. CONCLUSION

The revolution of clean renewable energy has started not long ago. We have been racing the clock since the latest developments regarding the situation of our planet. It is true that natural gas, oil and coal have been around for millenniums, they are very powerful and almost every power derived device is dependent on them. But they are not going to last forever, in fact, we have exploited massive amount of that in last one and a half century. Not to mention the lousy effect it left on the atmosphere from burning all that fossil fuel. The fact the world's energy consumption is actually increasing annually should give us enough motivation to put an end to unclean era on energy.

Recently, researchers have found incredible facts that shows how the world is filled with resources and materials enough to make a drastic switch and a change in the way we approach energy. Renewable energy resources are almost everywhere, from wind energy, to hydro, biomass and solar energies the world took its first leap towards improving the current status of our planet. Technologies were developed and perfected, tests were made, and studies were done, and a new chapter was written. Unfortunately, it was not all rainbow and sunshine, struggles and challenges were met some we overcome, and others are yet being researched.

With that being said, it was time to take another leap for a brighter, cleaner and emission free future. The next chapter was to foolproof a flawless energy generation system fully independent and functioning with backups that match the fluctuating needs of the grid. The energy storage system technologies was the futuristic move that we all have been waiting for. Not only do we get pure clean energy, but we also get to store the excess of that energy to be used at a later time when we need it. Technologies were coming from each sector and industry to be implemented and tested, there were major successes that were an eye opener of what the future holds. With more studies focused on this section of the energy generation world we could achieve what was once though impossible. A fully functioning world with 100% technologies, devices, machines and vehicles that are powered with clean energy and zero greenhouse gas emitting. This goal can only be reached via energy storage technologies, where you can always have enough energy.

17. REFERENCES

1. Scientists, U.o.C. *How Energy Storage Works* Union of Concerned Scientists 2015 [cited 2015 20/ February].
2. LOVELESS, M. *Energy Storage: The Key to a Reliable, Clean Electricity Supply*. 2012 [cited 2012 February 22].
3. Agency, T.U.E.P. *Energy Storage Energy and the Environment* 2018.
4. Hirscher, M., ed. *Handbook of Hydrogen Storage: New Materials for future Energy Storage*. 2009, WILEY-VCH. 352.
5. Andreas Zuttel, A.B., Louis Schlapbach, *Hydrogen as a Future Energy Carrier* 2008: WILEY-VCH.
6. Kodjo Agbossou, M.K., Jean Hamelin, Tapan K. BOse *Performance of a stand-Alone Renewable Energy System Based on Energy Storage as Hydrogen* 2004. 19.
7. P.P. Edwards, V.L.K., W.I.F. David, N.P. Brandon *Hydrogen and fuel cels: Towards a sustainable energy future*, in *Energy Policy*. 2008.
8. Marta Sevilla, R.M., *Energy storage applications of activated carbons: supercapacitors and hydrogen storage*. *Energy & Environmental Science*, 2014(4).
9. Energy, U.S.D.o., *Hydrogen Storage "Think Tank"*. 2003.
10. life, p.f. *Hydrogen for transport and the B&E report*. Available from: <https://planetforlife.com/h2/h2swiss.html>.
11. energies, p. *Hydrogen production*. 2015; Available from: <https://www.planete-energies.com/en/medias/close/hydrogen-production>.
12. Energy, O.o.E.E.R. *Hydrogen Production: Electrolysis*. hydrogen production processes; Available from: <https://www.energy.gov/eere/fuelcells/hydrogen-production-electrolysis>.
13. Center, F.S.E. *Hydrogen Basics- Storage*. 2015; Available from: <http://www.fsec.ucf.edu/en/consumer/hydrogen/basics/storage.htm>.
14. Europe, H. *Hydrogen Storage Technologies*; Available from: <https://hydrogeneurope.eu/hydrogen-storage>.
15. Hanane Dagdiugui, A.O., *Hydrogen Storage and Distribution: Implementation Scenarios* 2018.
16. Andrei V. Tchouvelev, N.P.N.J., *Regulatory Framework, Safety Aspects, and Social Acceptance of Hydrogen Energy Technologies*. 2019.
17. Zainul Abidin, K.R.K., *Single and Polystorage Technologies for Renewable-Based Hybrid Energy Systems*. 2019.
18. Program, U.S.D.o.E.H., *Technical Assessment: Cryo-Compressed Hydrogen Storage for Vehicular Applications*. 2006.
19. Dr. Klaas Kunze, D.O.K., *Cryo-Compressed Hydrogen Storage*. Cryogenic Cluster day, 2012.
20. Energy, O.o.E.E.R. *Hydrogen Delivery Fuel Cell Technologies office*.
21. A., Z., *Hydrogen storage methods*. 2004.
22. Elements, W. *Hydrogen Uses*. 2019.
23. Products, A. *Hydrogen Basics*. Available from: <http://www.airproducts.com/Industries/Energy/Power/Power-Generation/hydrogen-basics.aspx>.
24. Europe, H. *Hydrogen Applications* Available from: <https://hydrogeneurope.eu/hydrogen-applications>.
25. Hidrogeno, C.N.d. *Hydrogen Refueling Station* Available from: <https://www.cnh2.es/en/cnh2/hidrogena/>.
26. Electropaedia. *Battery and Energy Technology*. Energy Storage.
27. Coalition, C.H.-F.C. *Hydrogen and Fuel Cell Benefits* Available from: <http://chfcc.org/resources/hydrogen-fuel-cell-benefits/>.

28. Working, F.o. *18 Advantages and Disadvantages of Hydrogen Fuel Cells*. Available from: <https://futureofworking.com/10-advantages-and-disadvantages-of-hydrogen-fuel-cells/>.
29. Garage, G. *11 Big Advantages and Disadvantages of Hydrogen Fuel cells*. Available from: <https://greengarageblog.org/11-big-advantages-and-disadvantages-of-hydrogen-fuel-cells>.
30. Somaya Salamah, S.S., Gerardo Lage, *Thermal Energy Storage*. 2019. p. 29.
31. 123RF. *Thermal energy physics definition, example with water and kinetic energy moving particles generating heat*. Available from: https://www.123rf.com/photo_101078914_stock-vector-thermal-energy-physics-definition-example-with-water-and-kinetic-energy-moving-particles-generating-.html.
32. Ioan Sarbu, C.S., *A Comprehensive Revie of Thermal Energy Storage*. 2018.
33. *Benefits of Thermal Energy Storage*, in Nexant 2018.
34. Silvetti, B., *4 Benefits of Thermal Energy Storage*, in *Buildings*.
35. Davis, P.R., *Monitoring and controlling of thermal energy storage systems*. 2015.
36. Nguan H. Steven Tay, F.B., *High Temprature Thermal Storage Systems Using Phase Change Materials* 2018.
37. L.Wagner, *Overview of Energy Storage Technologies* 2014: Elsevier, Boston
38. J.Franz, C.A.O., A. Carlos, *Cryogenic Heat Engines Made Using Electrocaloric Capacitors*. American Physical Society 2001.
39. Werley, B.L., *Fire Hazards in Oxygen Systems*. 1991.
40. Knowlen, C.M., A.T.; Bruckner,A. P.; Hertzberg, A., *High efficiency Energy COntersion Systems for Liquid Nitrogen Automobiles*. 1998.
41. Kapoor, A., *CRYOCAR*. 2014.
42. Reyes, D.R., *Edward Liquid nitrogen Engine*. 2013.
43. Reserve, S. *Molten Salt Energy Storage*. Available from: <https://www.solarreserve.com/en/technology/molten-salt-energy-storage.html>.
44. Way, J. *Storing the Sun: Molten Salt Provides Highly Efficient Thermal Storage*. 2008.
45. HEINSIUS, R. *Could Cutting Edge Solar Energy Storage Technology Save the Navajo Generating Station?* 2017; Available from: <https://www.knau.org/post/could-cutting-edge-solar-energy-storage-technology-save-navajo-generating-station>.
46. Sheikh Khaleduzzaman Shah, L.A., *Seasonal thermal energy storage system for cold climate zones: A review of recent developments*. 2018.
47. ecovat. *Seasonal Thermal Energy Storage*. Available from: <https://www.ecovat.eu/seasonal-thermal-energy-storage/?lang=en>.
48. Kroposki, B., *Seasonal Energy Storage*.
49. Siegel, R., *The Pros and Cons of Energy Storage Systems*. Feb 23, 2013.
50. Futures, A.I.T., *Energy Storage: Making intermittent Power Dispachable*. 2011.
51. Global, R., *ADELE – Adiabatic compressed-air energy storage (CAES) for electricity supply*. 2013.
52. J.St. John, G.M., *Texas to Host 317 NW of Compressed Air Energy Storage*. 2013.
53. Association, E.S. *Compressed Air Energy Storage (CAES)*. Available from: <http://energystorage.org/compressed-air-energy-storage-caes>.
54. Greenage, T., *Compressed air Energy Storage*
55. Association, E.S. *FLywheels*. Available from: <http://energystorage.org/energy-storage/technologies/flywheels>.
56. Wiki, C. *Energy Storage: Flywheel*. Available from: <https://www.climatetechwiki.org/technology/jiqweb-es-fw>.
57. Niall Fitzgerald, P.L., *Pumped-hydro energy storage: potential for transformation from single dams*. 2012.

58. Association, E.S. *Pumped Hydroelectric Storage*. Available from: <http://energystorage.org/energy-storage/technologies/pumped-hydroelectric-storage>.
59. Nield, D., *Huge Global Study Just Smashed One of The Last Major Arguments Against Renewables* Science alert, 2019.
60. West, N. *IS PUMPED STORAGE HYDRO THE KEY TO INCREASING RENEWABLES IN AUSTRALIA?* November 16, 2016; Available from: <https://www.entura.com.au/is-pumped-storage-hydro-the-key-to-increasing-renewables-in-australia/>.
61. Mcdonald, G., *Rail Energy Storage Harnesses the Power of Gravity All the Livelong Day*. Seeker 2017.
62. Association, E.S. *Solid State Batteries*. Available from: <http://energystorage.org/energy-storage/storage-technology-comparisons/solid-state-batteries>.
63. Fox, A. *How Do SOLid State Batteries Work?* how things work 2018.
64. Polat, E. *This New Solid-State Battery Can Change the Energy Storage Industry*. March 4, 2017.
65. Lydersen, K., *9 ways to store energy on the grid*, in *Discover* 2015.
66. Electrosynthesis Company, I. *Energy Storage*. Available from: <https://electrosynthesis.com/energy-storage/>.
67. Alliance, E.E.E.R., *Superconducting Magnetic Energy Storage (SMES)*.
68. SuperPower. *Superconducting Magnetic Energy Storage (SMES)*. 2014; Available from: <http://www.superpower-inc.com/content/superconducting-magnetic-energy-storage-smes>.
69. Dvorak, P., *Say hello to SMES: Superconducting magnetic energy storage system*. WindPower engineering development August 4, 2017.
70. Patil, N., *Global Superconducting Magnetic Energy Storage (SMES) Systems Market Analysis 2019-2026 – Super Power Inc, American Superconductor Corporation, Bruker Energy & Supercon Technologies*. TIMES, April 8, 2019.
71. Bunta, J.K., *StarTram - revolution in orbit transport?* October 23, 2011.
72. Currie, S., *Energy Storage Projects a global overview of trends and developments*. Project Finance International, 2016(April 2016).
73. Fund, E.D. *Energy Storage market booms, with more growth to come*. Available from: <https://www.edf.org/energy/energy-storage>.
74. House, T.M. *Vehicle-to- Grid*. Available from: https://www.mobilityhouse.com/int_en/vehicle-to-grid.
75. Sieg, M., *V2G Frequency Control Launched in Germany*, in *pv magazine*. October 24, 2018.
76. University of DelWare, K.B.R. *Driving Clean Energy Forward*. June 25, 2019; Available from: <https://www.udel.edu/udaily/2019/june/vehicle-to-grid-integration-becomes-law/>.