



UNIVERSIDADE DA CORUÑA



Escola Politécnica Superior

**TRABAJO FIN DE GRADO  
CURSO 2017/18**

---

*Buque PSV. Buque de suministro a plataformas de 5000  
TPM*

---

**Grado en Ingeniería Naval Oceánica**

**CUADERNO 4  
Cálculos de arquitectura naval**

**Sandra Allegue García**

**PROYECTO 18-02**

**GRADO EN INGENIERÍA NAVAL Y OCEÁNICA**  
**TRABAJO DE FIN DE GRADO**

*CURSO 2.017-2018*

**PROYECTO NÚMERO 18-02**

**TIPO DE BUQUE:** Buque PSV (Platform Vessel Supply). Buque de suministro a plataformas.

**CLASIFICACIÓN, COTA Y REGLAMENTOS DE APLICACIÓN:** DNV GL, SOLAS, MARPOL.

**CARACTERÍSTICAS DE LA CARGA:** Carga líquida y seca a granel para suministro a plataformas, 5000 TPM.

**VELOCIDAD Y AUTONOMÍA:** 13 nudos en condiciones de servicio al 85% de MCR y 15% de margen de mar. 6000 millas a la velocidad de servicio

**SISTEMAS Y EQUIPOS DE CARGA / DESCARGA:** Bombas para la carga y descarga de la carga líquida. Dos grúas.

**PROPULSIÓN:** Propulsión diésel-eléctrica. LNG para estancias en puerto

**TRIPULACIÓN Y PASAJE:** 35 personas.

**OTROS EQUIPOS E INSTALACIONES:** Sistema de posicionamiento dinámico con redundancia DP 3. FIFI

Ferrol, 2 Noviembre 2017

**ALUMNO/A: D<sup>a</sup> Sandra Allegue García**

# ÍNDICE

---

|       |  |    |
|-------|--|----|
| 1     | Introducción.....                                      | 5  |
| 2     | Cálculo de hidrostáticas .....                         | 6  |
| 2.1   | Trimado + 0,8 m .....                                  | 7  |
| 2.2   | Trimado 0 m.....                                       | 10 |
| 2.3   | Trimado - 0,8 m .....                                  | 13 |
| 3     | Cálculo de curvas KN .....                             | 16 |
| 3.1   | Trimado + 0,8 m .....                                  | 16 |
| 3.2   | Trimado 0 m.....                                       | 18 |
| 3.3   | Trimado - 0,8 m.....                                   | 19 |
| 4     | Zona estanca y puntos de inundación progresiva .....   | 20 |
| 5     | Compartimentado.....                                   | 21 |
| 5.1   | Compartimentado longitudinal .....                     | 21 |
| 5.1.1 | Separación de cuadernas.....                           | 21 |
| 5.1.2 | Pique de popa .....                                    | 21 |
| 5.1.3 | Espacios de bodega.....                                | 21 |
| 5.1.4 | Cámara de bombas .....                                 | 21 |
| 5.1.5 | Cámara de máquinas.....                                | 21 |
| 5.1.6 | Local del propulsor de proa .....                      | 22 |
| 5.1.7 | Pique de proa .....                                    | 22 |
| 5.2   | Compartimentado transversal.....                       | 23 |
| 5.3   | Compartimentado vertical .....                         | 24 |
| 5.3.1 | Doble fondo .....                                      | 24 |
| 5.3.2 | Cubiertas.....   | 24 |
| 5.4   | Resumen del compartimentado .....                      | 24 |
| 6     | Tanques y capacidades .....                            | 26 |
| 6.1   | Consumos.....  | 26 |
| 6.1.1 | Combustible.....                                       | 26 |
| 6.1.2 | Diesel oíl de uso diario .....                         | 26 |
| 6.1.3 | Diesel oíl de sedimentación.....                       | 26 |
| 6.1.4 | Aceite de lubricación.....                             | 27 |
| 6.1.5 | Agua técnica .....                                     | 27 |
| 6.1.6 | Aguas negras/grises.....                               | 27 |
| 6.1.7 | Agua potable.....                                      | 28 |
| 6.1.8 | Aceite usado y lodos (residuos de hidrocarburos) ..... | 29 |
| 6.2   | tanques de lastre .....                                | 30 |

|  |  |    |
|--|--|----|
| 6.3  | Tanques de cemento .....   | 30 |
| 6.4  | Tanques de barro de perforación y residuos de hidrocarburos .....  | 31 |
| 6.5  | Tanques de metanol y xileno.....                                   | 31 |
| 6.6  | Tanques de productos especiales y base oíl.....                    | 31 |
| 6.7  | Tabla resumen de capacidades.....                                  | 32 |
| 6.8  | Listado de tanques y comprobación de capacidades. carga útil ..... | 32 |
| ANEXO 1: Zona estanca y puntos de inundación progresiva..... |  | 37 |
| ANEXO 2: Compartimentado.....                                |  | 38 |
| ANEXO 3: Planos de tanques.....                              |  | 39 |
| ANEXO 4: Calibraciones de tanques.....                       |  | 40 |

## 1 INTRODUCCIÓN

---

En este cuaderno se determinarán todos los cálculos de la Arquitectura Naval en los que se incluyen el cálculo de las hidrostáticas, así como las curvas KN, tanques y capacidades del buque y el compartimentado.

En el caso del compartimentado se situarán los mamparos estancos longitudinales, transversales y verticales. Así como la disposición de las cuernas y bulárcamas.

Mediante la aplicación del convenio SOLAS y del reglamento DNV GL, se determinará la posición de cada uno de los espacios del buque, así como la determinación del doble casco, el doble fondo y la altura de las cubiertas.

Se indicará también todas las posiciones de los tanques necesarios para suministro de la plataforma, así como los consumos del propio buque, la zona estanca y las zonas de inundación progresiva del buque.

Con relación a las tablas hidrostáticas, las curvas KN y las calibraciones se obtendrán con el programa Maxsurf, usado anteriormente en el Cuaderno 3.

Las dimensiones principales obtenidas en el Cuaderno 1 son:

|                    |
|--------------------|
| Lpp = 78,58 m      |
| Loa = 85,78 m      |
| B = 19,13 m        |
| T = 6,578 m        |
| D = 8,261 m        |
| BHP = 1985 kW      |
| $\Delta$ = 7.742 t |
| Fn = 0,241         |
| Cb = 0,764         |
| Cm = 0,989         |
| Cp = 0,772         |
| Cf = 0,925         |

## 2 CÁLCULO DE HIDROSTÁTICAS

Para este cálculo se utilizará, como se ha indicado en la introducción del Cuaderno, el programa Maxsurf Stability Enterprise.

Para hacer el cálculo de las tablas se utilizará como criterio el desplazamiento del buque indicando el peso en rosca del buque y el desplazamiento final del buque. En este caso, como se quiere que las hidrostáticas tengan doce columnas se utilizará un desplazamiento un poco superior al indicado, para que no existan columnas intermedias con decimales:

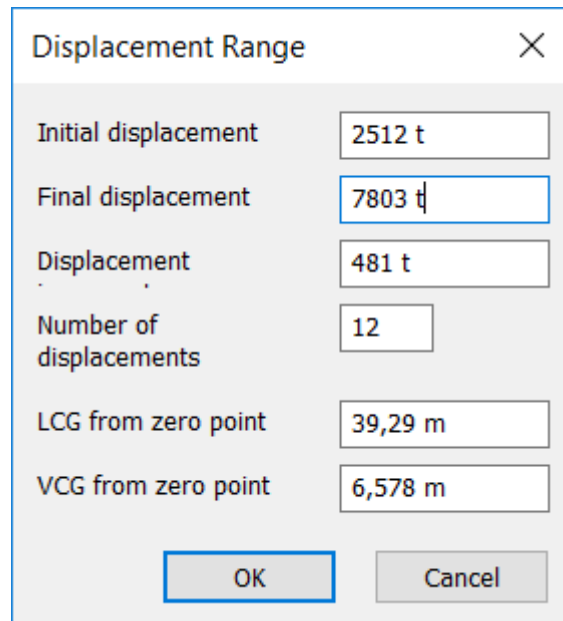

| Field                   | Value   |
|-------------------------|---------|
| Initial displacement    | 2512 t  |
| Final displacement      | 7803 t  |
| Displacement            | 481 t   |
| Number of displacements | 12      |
| LCG from zero point     | 39,29 m |
| VCG from zero point     | 6,578 m |

Además, se dispondrán de varias tablas debido a que el estudio se realizará con diferentes trimados. En este caso se han elegido tres trimados diferentes:

- - 0,8 m,
- 0 m y
- + 0,8 m.

Se han elegido estos valores debido a que es el valor que corresponde al 1 % de la eslora del buque.

Como se verá, los valores no se ajustan exactamente a los obtenidos anteriormente, pero difieren una cantidad que está dentro de unos límites aceptables.

## 2.1 TRIMADO + 0,8 M

| Draft Amidships<br>m             | 2,559    | 2,962    | 3,356    | 3,743    | 4,121    | 4,491    | 4,854    | 5,208    | 5,556    | 5,899    | 6,239    | 6,579    |
|----------------------------------|----------|----------|----------|----------|----------|----------|----------|----------|----------|----------|----------|----------|
| Displacement t                   | 2512     | 2993     | 3474     | 3955     | 4436     | 4917     | 5398     | 5879     | 6360     | 6841     | 7322     | 7803     |
| Heel deg                         | 0,0      | 0,0      | 0,0      | 0,0      | 0,0      | 0,0      | 0,0      | 0,0      | 0,0      | 0,0      | 0,0      | 0,0      |
| Draft at FP m                    | 2,159    | 2,562    | 2,956    | 3,343    | 3,721    | 4,091    | 4,454    | 4,808    | 5,156    | 5,499    | 5,839    | 6,179    |
| Draft at AP m                    | 2,959    | 3,362    | 3,756    | 4,143    | 4,521    | 4,891    | 5,254    | 5,608    | 5,956    | 6,299    | 6,639    | 6,979    |
| Draft at LCF m                   | 2,575    | 2,984    | 3,381    | 3,775    | 4,157    | 4,534    | 4,903    | 5,263    | 5,616    | 5,963    | 6,304    | 6,645    |
| Trim (+ve by stern) m            | 0,800    | 0,800    | 0,800    | 0,800    | 0,800    | 0,800    | 0,800    | 0,800    | 0,800    | 0,800    | 0,800    | 0,800    |
| WL Length m                      | 80,835   | 81,202   | 81,493   | 81,731   | 81,938   | 83,030   | 84,295   | 85,487   | 86,607   | 87,352   | 87,313   | 87,172   |
| Beam max extents on<br>WL m      | 19,123   | 19,127   | 19,130   | 19,131   | 19,132   | 19,132   | 19,132   | 19,131   | 19,131   | 19,131   | 19,131   | 19,132   |
| Wetted Area m <sup>2</sup>       | 1422,426 | 1519,822 | 1604,624 | 1689,851 | 1768,811 | 1861,346 | 1956,082 | 2036,712 | 2115,918 | 2190,208 | 2249,115 | 2309,754 |
| Waterpl. Area m <sup>2</sup>     | 1147,173 | 1179,847 | 1199,781 | 1231,827 | 1251,278 | 1278,480 | 1313,910 | 1337,839 | 1359,994 | 1376,112 | 1378,876 | 1379,848 |
| Prismatic coeff. (Cp)            | 0,632    | 0,652    | 0,668    | 0,682    | 0,696    | 0,708    | 0,719    | 0,730    | 0,740    | 0,750    | 0,759    | 0,768    |
| Block coeff. (Cb)                | 0,558    | 0,584    | 0,606    | 0,625    | 0,642    | 0,657    | 0,671    | 0,684    | 0,697    | 0,709    | 0,719    | 0,729    |
| Max Sect. area coeff.<br>(Cm)    | 0,949    | 0,955    | 0,960    | 0,964    | 0,967    | 0,970    | 0,972    | 0,974    | 0,975    | 0,977    | 0,978    | 0,979    |
| Waterpl. area coeff.<br>(Cwp)    | 0,763    | 0,785    | 0,798    | 0,819    | 0,832    | 0,850    | 0,874    | 0,890    | 0,905    | 0,915    | 0,917    | 0,918    |
| LCB from zero pt.<br>(+ve fwd) m | 37,645   | 37,614   | 37,523   | 37,409   | 37,248   | 37,065   | 36,862   | 36,643   | 36,416   | 36,185   | 35,972   | 35,782   |
| LCF from zero pt.<br>(+ve fwd) m | 37,732   | 37,157   | 36,827   | 36,144   | 35,760   | 35,074   | 34,451   | 33,891   | 33,365   | 32,979   | 32,918   | 32,863   |
| KB m                             | 1,416    | 1,635    | 1,849    | 2,061    | 2,268    | 2,471    | 2,671    | 2,868    | 3,063    | 3,255    | 3,444    | 3,631    |
| KG m                             | 6,578    | 6,578    | 6,578    | 6,578    | 6,578    | 6,578    | 6,578    | 6,578    | 6,578    | 6,578    | 6,578    | 6,578    |
| BMt m                            | 11,829   | 10,300   | 9,120    | 8,283    | 7,559    | 7,017    | 6,555    | 6,162    | 5,819    | 5,509    | 5,188    | 4,897    |
| BML m                            | 166,309  | 151,287  | 136,948  | 129,174  | 120,075  | 115,405  | 110,760  | 106,638  | 102,863  | 98,442   | 92,026   | 85,988   |
| GMt m                            | 6,651    | 5,340    | 4,374    | 3,747    | 3,228    | 2,888    | 2,624    | 2,426    | 2,275    | 2,154    | 2,020    | 1,914    |
| GML m                            | 161,131  | 146,328  | 132,202  | 124,638  | 115,744  | 111,276  | 106,829  | 102,901  | 99,319   | 95,087   | 88,858   | 83,005   |
| KMt m                            | 13,245   | 11,934   | 10,969   | 10,343   | 9,826    | 9,488    | 9,226    | 9,030    | 8,882    | 8,763    | 8,632    | 8,528    |
| KML m                            | 167,717  | 152,915  | 138,790  | 131,228  | 122,337  | 117,870  | 113,425  | 109,501  | 105,921  | 101,692  | 95,465   | 89,615   |

SANDRA ALLEGUE GARCÍA  
CUADERNO 4

| <b>Draft Amidships<br/>m</b>               | <b>2,559</b> | <b>2,962</b> | <b>3,356</b> | <b>3,743</b> | <b>4,121</b> | <b>4,491</b> | <b>4,854</b> | <b>5,208</b> | <b>5,556</b> | <b>5,899</b> | <b>6,239</b> | <b>6,579</b> |
|--|--------------|--------------|--------------|--------------|--------------|--------------|--------------|--------------|--------------|--------------|--------------|--------------|
| Immersion (TPc)<br>tonne/cm                | 11,759       | 12,093       | 12,298       | 12,626       | 12,826       | 13,104       | 13,468       | 13,713       | 13,940       | 14,105       | 14,133       | 14,143       |
| MTc tonne.m                                | 51,509       | 55,734       | 58,446       | 62,732       | 65,340       | 69,629       | 73,385       | 76,986       | 80,386       | 82,781       | 82,797       | 82,424       |
| RM at 1deg =<br>GMt.Disp.sin(1)<br>tonne.m | 291,586      | 278,945      | 265,202      | 258,609      | 249,923      | 247,800      | 247,212      | 248,898      | 252,521      | 257,171      | 258,149      | 260,711      |
| Max deck inclination<br>deg                | 0,5833       | 0,5833       | 0,5833       | 0,5833       | 0,5833       | 0,5833       | 0,5833       | 0,5833       | 0,5833       | 0,5833       | 0,5833       | 0,5833       |
| Trim angle (+ve by<br>stern) deg           | 0,5833       | 0,5833       | 0,5833       | 0,5833       | 0,5833       | 0,5833       | 0,5833       | 0,5833       | 0,5833       | 0,5833       | 0,5833       | 0,5833       |



SANDRA ALLEGUE GARCÍA  
CUADERNO 4

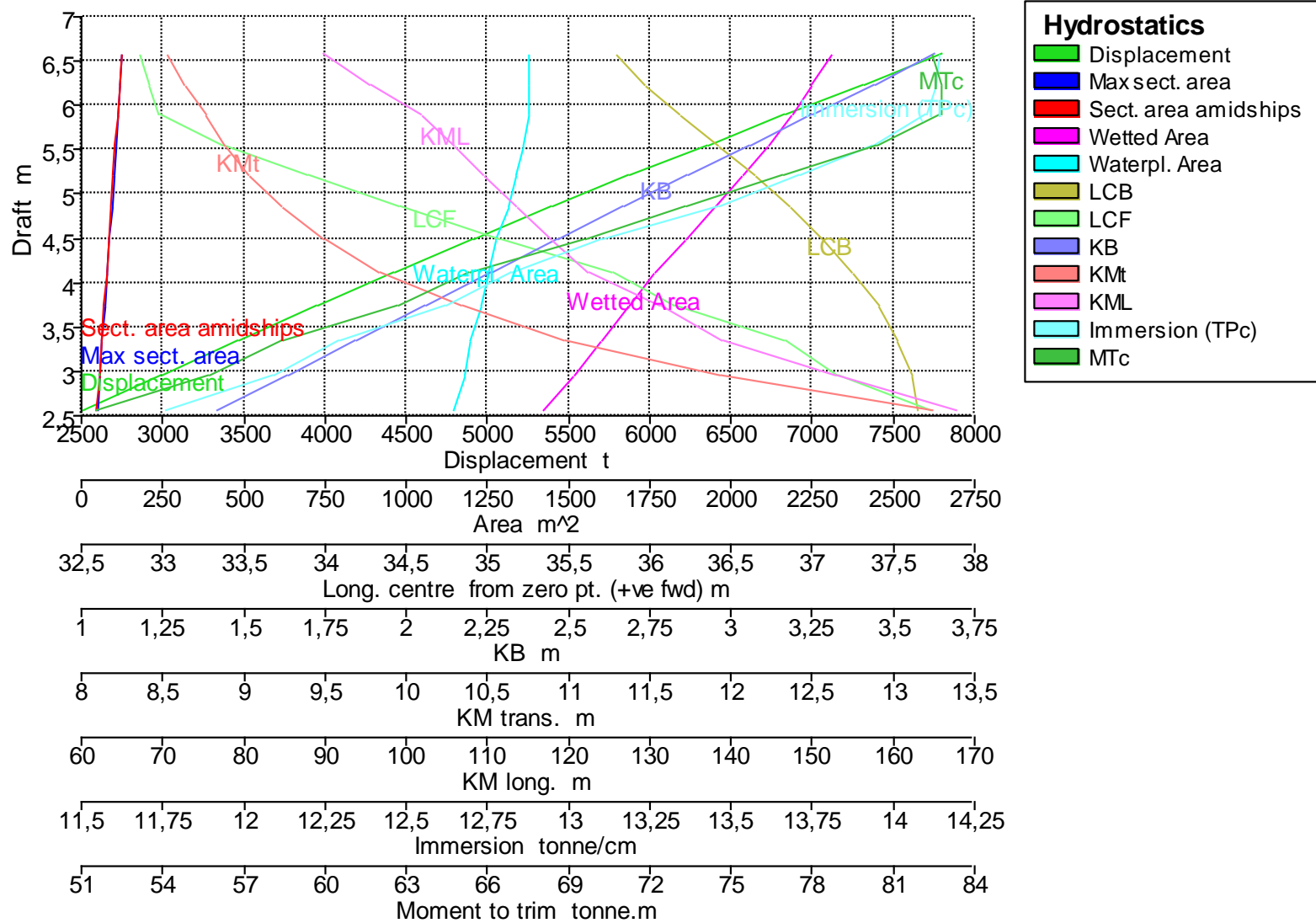

## 2.2 TRIMADO 0 M

| Draft Amidships<br>m             | 2,572    | 2,980    | 3,379    | 3,770    | 4,155    | 4,531    | 4,900    | 5,260    | 5,614    | 5,961    | 6,304    | 6,645    |
|----------------------------------|----------|----------|----------|----------|----------|----------|----------|----------|----------|----------|----------|----------|
| Displacement t                   | 2512     | 2993     | 3474     | 3955     | 4436     | 4917     | 5398     | 5879     | 6360     | 6841     | 7322     | 7803     |
| Heel deg                         | 0,0      | 0,0      | 0,0      | 0,0      | 0,0      | 0,0      | 0,0      | 0,0      | 0,0      | 0,0      | 0,0      | 0,0      |
| Draft at FP m                    | 2,572    | 2,980    | 3,379    | 3,770    | 4,155    | 4,531    | 4,900    | 5,260    | 5,614    | 5,961    | 6,304    | 6,645    |
| Draft at AP m                    | 2,572    | 2,980    | 3,379    | 3,770    | 4,155    | 4,531    | 4,900    | 5,260    | 5,614    | 5,961    | 6,304    | 6,645    |
| Draft at LCF m                   | 2,572    | 2,980    | 3,379    | 3,770    | 4,155    | 4,531    | 4,900    | 5,260    | 5,614    | 5,961    | 6,304    | 6,645    |
| Trim (+ve by stern) m            | 0,000    | 0,000    | 0,000    | 0,000    | 0,000    | 0,000    | 0,000    | 0,000    | 0,000    | 0,000    | 0,000    | 0,000    |
| WL Length m                      | 81,045   | 81,337   | 81,577   | 81,787   | 81,976   | 82,147   | 83,236   | 84,399   | 85,467   | 86,417   | 87,018   | 83,469   |
| Beam max extents on<br>WL m      | 19,121   | 19,127   | 19,129   | 19,131   | 19,132   | 19,132   | 19,132   | 19,131   | 19,131   | 19,131   | 19,131   | 19,129   |
| Wetted Area m <sup>2</sup>       | 1414,407 | 1501,979 | 1598,289 | 1689,501 | 1764,553 | 1847,027 | 1947,501 | 2028,644 | 2107,730 | 2186,195 | 2263,288 | 2326,530 |
| Waterpl. Area m <sup>2</sup>     | 1135,287 | 1156,325 | 1186,580 | 1215,491 | 1237,026 | 1252,633 | 1292,265 | 1316,138 | 1338,601 | 1358,817 | 1374,707 | 1379,622 |
| Prismatic coeff. (Cp)            | 0,659    | 0,674    | 0,687    | 0,699    | 0,710    | 0,720    | 0,730    | 0,740    | 0,749    | 0,758    | 0,766    | 0,774    |
| Block coeff. (Cb)                | 0,624    | 0,643    | 0,659    | 0,673    | 0,686    | 0,698    | 0,709    | 0,720    | 0,730    | 0,740    | 0,749    | 0,757    |
| Max Sect. area coeff.<br>(Cm)    | 0,963    | 0,968    | 0,971    | 0,974    | 0,977    | 0,979    | 0,980    | 0,982    | 0,983    | 0,984    | 0,985    | 0,985    |
| Waterpl. area coeff.<br>(Cwp)    | 0,756    | 0,769    | 0,789    | 0,809    | 0,823    | 0,833    | 0,860    | 0,875    | 0,890    | 0,904    | 0,914    | 0,918    |
| LCB from zero pt.<br>(+ve fwd) m | 39,319   | 39,125   | 38,905   | 38,678   | 38,455   | 38,212   | 37,963   | 37,703   | 37,439   | 37,172   | 36,903   | 36,651   |
| LCF from zero pt.<br>(+ve fwd) m | 38,329   | 37,986   | 37,329   | 36,692   | 36,228   | 35,832   | 35,053   | 34,481   | 33,912   | 33,366   | 32,880   | 32,839   |
| KB m                             | 1,408    | 1,628    | 1,843    | 2,053    | 2,261    | 2,465    | 2,666    | 2,863    | 3,058    | 3,250    | 3,439    | 3,626    |
| KG m                             | 6,578    | 6,578    | 6,578    | 6,578    | 6,578    | 6,578    | 6,578    | 6,578    | 6,578    | 6,578    | 6,578    | 6,578    |
| BMt m                            | 11,619   | 10,046   | 8,971    | 8,120    | 7,441    | 6,865    | 6,438    | 6,056    | 5,729    | 5,437    | 5,181    | 4,921    |
| BML m                            | 162,484  | 143,740  | 133,088  | 124,585  | 116,300  | 108,901  | 105,472  | 101,551  | 97,970   | 94,465   | 90,560   | 85,068   |
| GMt m                            | 6,449    | 5,096    | 4,236    | 3,595    | 3,125    | 2,752    | 2,526    | 2,341    | 2,208    | 2,109    | 2,042    | 1,969    |
| GML m                            | 157,314  | 138,789  | 128,353  | 120,061  | 111,983  | 104,788  | 101,560  | 97,836   | 94,450   | 91,136   | 87,421   | 82,116   |
| KMt m                            | 13,027   | 11,674   | 10,814   | 10,173   | 9,703    | 9,330    | 9,104    | 8,919    | 8,786    | 8,687    | 8,620    | 8,547    |
| KML m                            | 163,892  | 145,367  | 134,931  | 126,639  | 118,561  | 111,366  | 108,138  | 104,414  | 101,028  | 97,714   | 93,999   | 88,694   |

SANDRA ALLEGUE GARCÍA  
CUADERNO 4

| <b>Draft Amidships<br/>m</b>               | <b>2,572</b> | <b>2,980</b> | <b>3,379</b> | <b>3,770</b> | <b>4,155</b> | <b>4,531</b> | <b>4,900</b> | <b>5,260</b> | <b>5,614</b> | <b>5,961</b> | <b>6,304</b> | <b>6,645</b> |
|--|--------------|--------------|--------------|--------------|--------------|--------------|--------------|--------------|--------------|--------------|--------------|--------------|
| Immersion (TPc)<br>tonne/cm                | 11,637       | 11,852       | 12,162       | 12,459       | 12,680       | 12,839       | 13,246       | 13,490       | 13,721       | 13,928       | 14,091       | 14,141       |
| MTc tonne.m                                | 50,289       | 52,863       | 56,745       | 60,428       | 63,217       | 65,569       | 69,766       | 73,196       | 76,444       | 79,342       | 81,458       | 81,542       |
| RM at 1deg =<br>GMt.Disp.sin(1)<br>tonne.m | 282,705      | 266,192      | 256,799      | 248,157      | 241,902      | 236,149      | 237,924      | 240,212      | 245,119      | 251,762      | 260,901      | 268,178      |
| Max deck inclination<br>deg                | 0,0000       | 0,0000       | 0,0000       | 0,0000       | 0,0000       | 0,0000       | 0,0000       | 0,0000       | 0,0000       | 0,0000       | 0,0000       | 0,0000       |
| Trim angle (+ve by<br>stern) deg           | 0,0000       | 0,0000       | 0,0000       | 0,0000       | 0,0000       | 0,0000       | 0,0000       | 0,0000       | 0,0000       | 0,0000       | 0,0000       | 0,0000       |

SANDRA ALLEGUE GARCÍA  
CUADERNO 4

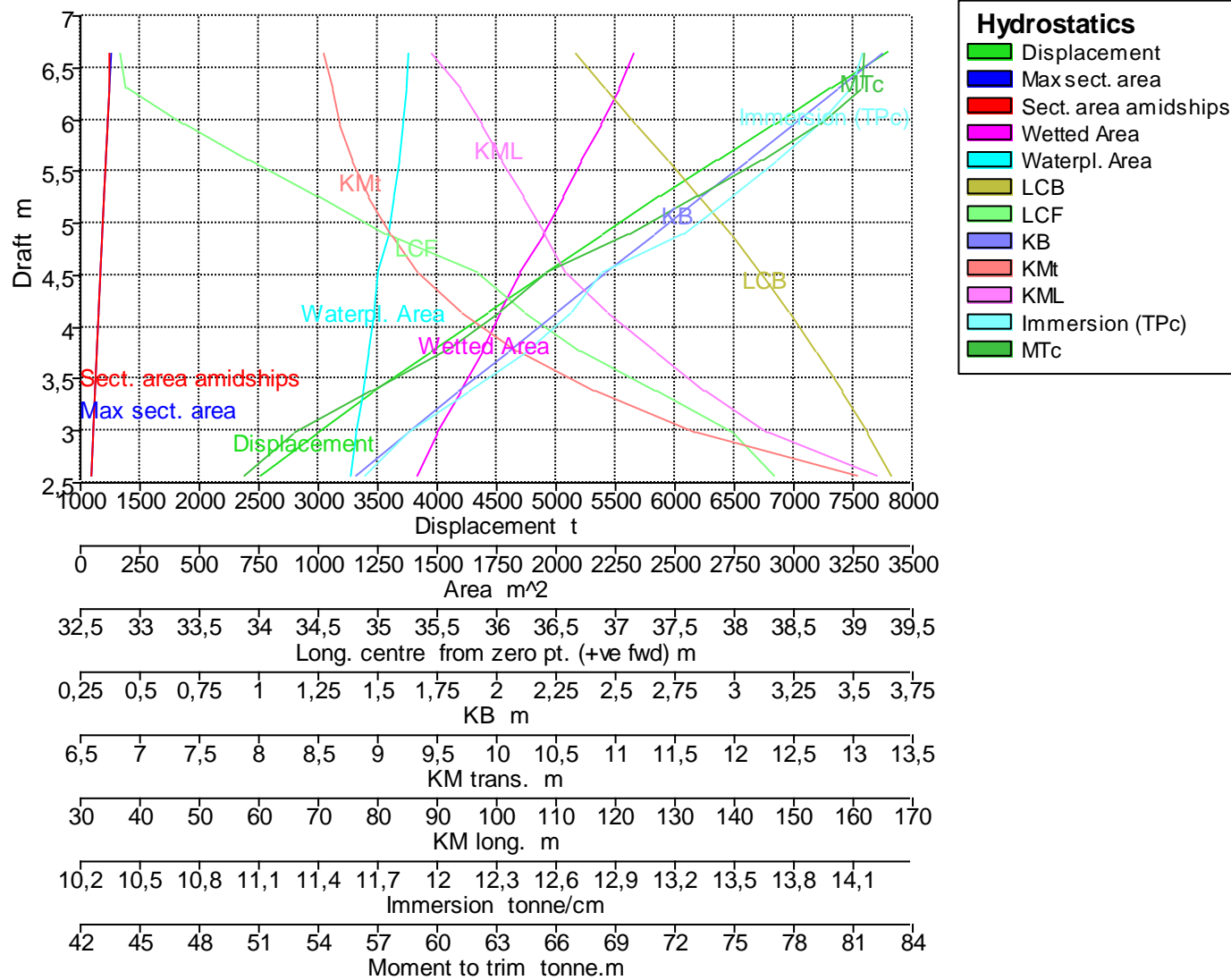

### 2.3 TRIMADO - 0,8 M

| Draft Amidships m             | 2,578    | 2,992    | 3,397    | 3,793    | 4,182    | 4,565    | 4,940    | 5,306    | 5,666    | 6,019    | 6,368    | 6,709    |
|-------------------------------|----------|----------|----------|----------|----------|----------|----------|----------|----------|----------|----------|----------|
| Displacement t                | 2512     | 2993     | 3474     | 3955     | 4436     | 4917     | 5398     | 5879     | 6360     | 6841     | 7322     | 7803     |
| Heel deg                      | 0,0      | 0,0      | 0,0      | 0,0      | 0,0      | 0,0      | 0,0      | 0,0      | 0,0      | 0,0      | 0,0      | 0,0      |
| Draft at FP m                 | 2,978    | 3,392    | 3,797    | 4,193    | 4,582    | 4,965    | 5,340    | 5,706    | 6,066    | 6,419    | 6,768    | 7,109    |
| Draft at AP m                 | 2,178    | 2,592    | 2,997    | 3,393    | 3,782    | 4,165    | 4,540    | 4,906    | 5,266    | 5,619    | 5,968    | 6,309    |
| Draft at LCF m                | 2,575    | 2,984    | 3,382    | 3,774    | 4,155    | 4,534    | 4,902    | 5,263    | 5,616    | 5,963    | 6,308    | 6,647    |
| Trim (+ve by stern) m         | -0,800   | -0,800   | -0,800   | -0,800   | -0,800   | -0,800   | -0,800   | -0,800   | -0,800   | -0,800   | -0,800   | -0,800   |
| WL Length m                   | 81,173   | 81,418   | 81,632   | 81,824   | 81,997   | 82,145   | 82,249   | 83,248   | 84,202   | 84,900   | 82,646   | 83,717   |
| Beam max extents on WL m      | 19,119   | 19,126   | 19,129   | 19,131   | 19,131   | 19,132   | 19,132   | 19,131   | 19,131   | 19,131   | 19,131   | 19,129   |
| Wetted Area m <sup>2</sup>    | 1403,217 | 1490,683 | 1588,409 | 1673,529 | 1766,193 | 1843,289 | 1929,867 | 2019,914 | 2100,684 | 2181,872 | 2262,308 | 2338,020 |
| Waterpl. Area m <sup>2</sup>  | 1119,978 | 1145,208 | 1174,477 | 1191,898 | 1221,451 | 1237,833 | 1264,923 | 1294,312 | 1316,056 | 1335,552 | 1360,761 | 1389,525 |
| Prismatic coeff. (Cp)         | 0,662    | 0,676    | 0,688    | 0,700    | 0,710    | 0,720    | 0,729    | 0,738    | 0,746    | 0,755    | 0,763    | 0,771    |
| Block coeff. (Cb)             | 0,579    | 0,601    | 0,620    | 0,637    | 0,651    | 0,664    | 0,676    | 0,688    | 0,699    | 0,709    | 0,719    | 0,729    |
| Max Sect. area coeff. (Cm)    | 0,961    | 0,967    | 0,970    | 0,974    | 0,976    | 0,978    | 0,980    | 0,981    | 0,983    | 0,983    | 0,984    | 0,985    |
| Waterpl. area coeff. (Cwp)    | 0,745    | 0,762    | 0,781    | 0,793    | 0,812    | 0,823    | 0,841    | 0,861    | 0,875    | 0,888    | 0,905    | 0,924    |
| LCB from zero pt. (+ve fwd) m | 40,943   | 40,580   | 40,240   | 39,915   | 39,600   | 39,310   | 39,012   | 38,710   | 38,409   | 38,107   | 37,806   | 37,527   |
| LCF from zero pt. (+ve fwd) m | 38,938   | 38,472   | 37,797   | 37,404   | 36,695   | 36,259   | 35,555   | 35,025   | 34,417   | 33,782   | 33,363   | 33,224   |
| KB m                          | 1,416    | 1,635    | 1,849    | 2,060    | 2,266    | 2,470    | 2,671    | 2,868    | 3,063    | 3,254    | 3,444    | 3,631    |
| KG m                          | 6,578    | 6,578    | 6,578    | 6,578    | 6,578    | 6,578    | 6,578    | 6,578    | 6,578    | 6,578    | 6,578    | 6,578    |
| BMt m                         | 11,372   | 9,881    | 8,815    | 7,948    | 7,318    | 6,764    | 6,323    | 5,955    | 5,638    | 5,362    | 5,132    | 4,946    |
| BML m                         | 157,266  | 139,664  | 128,988  | 118,060  | 112,155  | 105,146  | 101,256  | 96,441   | 92,792   | 89,133   | 87,449   | 86,854   |
| GMt m                         | 6,193    | 4,925    | 4,077    | 3,424    | 3,003    | 2,656    | 2,419    | 2,251    | 2,131    | 2,051    | 2,013    | 2,017    |
| GML m                         | 152,088  | 134,708  | 124,250  | 113,536  | 107,840  | 101,039  | 97,352   | 92,738   | 89,286   | 85,821   | 84,330   | 83,925   |
| KMt m                         | 12,787   | 11,515   | 10,664   | 10,008   | 9,584    | 9,234    | 8,993    | 8,823    | 8,700    | 8,616    | 8,576    | 8,577    |
| KML m                         | 158,674  | 141,292  | 130,831  | 120,114  | 114,415  | 107,611  | 103,922  | 99,305   | 95,850   | 92,382   | 90,888   | 90,480   |

SANDRA ALLEGUE GARCÍA  
CUADERNO 4

| <b>Draft Amidships<br/>m</b>               | <b>2,578</b> | <b>2,992</b> | <b>3,397</b> | <b>3,793</b> | <b>4,182</b> | <b>4,565</b> | <b>4,940</b> | <b>5,306</b> | <b>5,666</b> | <b>6,019</b> | <b>6,368</b> | <b>6,709</b> |
|--|--------------|--------------|--------------|--------------|--------------|--------------|--------------|--------------|--------------|--------------|--------------|--------------|
| Immersion (TPc)<br>tonne/cm                | 11,480       | 11,738       | 12,038       | 12,217       | 12,520       | 12,688       | 12,965       | 13,267       | 13,490       | 13,689       | 13,948       | 14,243       |
| MTc tonne.m                                | 48,619       | 51,308       | 54,931       | 57,143       | 60,878       | 63,223       | 66,875       | 69,382       | 72,265       | 74,714       | 78,577       | 83,337       |
| RM at 1deg =<br>GMt.Disp.sin(1)<br>tonne.m | 271,508      | 257,250      | 247,176      | 236,325      | 232,506      | 227,950      | 227,860      | 231,000      | 236,575      | 244,861      | 257,257      | 274,676      |
| Max deck inclination<br>deg                | 0,5833       | 0,5833       | 0,5833       | 0,5833       | 0,5833       | 0,5833       | 0,5833       | 0,5833       | 0,5833       | 0,5833       | 0,5833       | 0,5833       |
| Trim angle (+ve by<br>stern) deg           | -0,5833      | -0,5833      | -0,5833      | -0,5833      | -0,5833      | -0,5833      | -0,5833      | -0,5833      | -0,5833      | -0,5833      | -0,5833      | -0,5833      |

SANDRA ALLEGUE GARCÍA  
CUADERNO 4

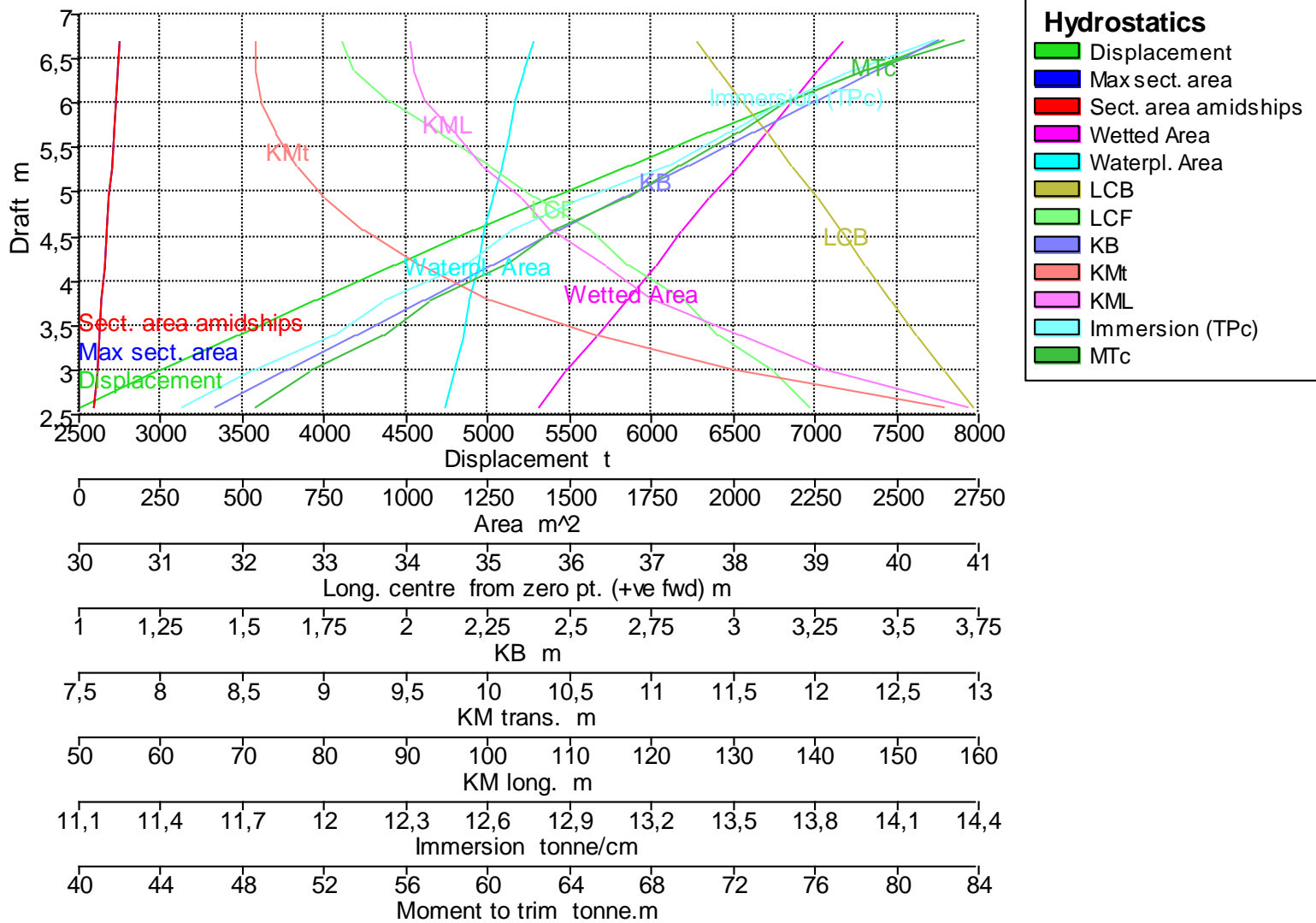

### 3 CÁLCULO DE CURVAS KN

Para el cálculo de las curvas KN se hará lo mismo que en el apartado anterior.

Mediante el programa Maxsurf Stability Enterprise se hará el análisis mediante el desplazamiento del buque y para los trimados anteriormente explicados.

Además, se dispondrán de cinco curvas KN, una cada 10 grados, se ha escogido hasta el valor de 50 grados debido a que es poco probable que un buque sobrepase ese valor.

#### 3.1 TRIMADO + 0,8 m

| Displacement<br>(intact)<br>tonne | Draft<br>Amidshi<br>ps<br>m | Trim<br>(+ve<br>by<br>stern)<br>m | LCG<br>m | TCG<br>m | Assu<br>med<br>VCG<br>m | KN<br>10,0<br>deg.<br>Starb. | KN<br>20,0<br>deg.<br>Starb. | KN<br>30,0<br>deg.<br>Starb. | KN<br>40,0<br>deg.<br>Starb. | KN<br>50,0<br>deg.<br>Starb. |
|-----------------------------------|-----------------------------|-----------------------------------|----------|----------|-------------------------|------------------------------|------------------------------|------------------------------|------------------------------|------------------------------|
| 2512                              | 2,559                       | 0,800                             | 37,630   | 0,000    | 0,000                   | 2,303                        | 4,272                        | 5,466                        | 6,280                        | 6,612                        |
| 2993                              | 2,962                       | 0,800                             | 37,597   | 0,000    | 0,000                   | 2,082                        | 4,015                        | 5,316                        | 6,142                        | 6,499                        |
| 3474                              | 3,356                       | 0,800                             | 37,504   | 0,000    | 0,000                   | 1,923                        | 3,797                        | 5,194                        | 5,987                        | 6,343                        |
| 3955                              | 3,743                       | 0,800                             | 37,388   | 0,000    | 0,000                   | 1,808                        | 3,612                        | 5,065                        | 5,824                        | 6,167                        |
| 4436                              | 4,121                       | 0,800                             | 37,224   | 0,000    | 0,000                   | 1,723                        | 3,460                        | 4,908                        | 5,652                        | 5,993                        |
| 4917                              | 4,491                       | 0,800                             | 37,040   | 0,000    | 0,000                   | 1,661                        | 3,339                        | 4,727                        | 5,467                        | 5,817                        |
| 5398                              | 4,854                       | 0,800                             | 36,835   | 0,000    | 0,000                   | 1,614                        | 3,243                        | 4,528                        | 5,268                        | 5,634                        |
| 5879                              | 5,208                       | 0,800                             | 36,614   | 0,000    | 0,000                   | 1,577                        | 3,145                        | 4,314                        | 5,053                        | 5,441                        |
| 6360                              | 5,556                       | 0,800                             | 36,385   | 0,000    | 0,000                   | 1,549                        | 3,029                        | 4,091                        | 4,825                        | 5,237                        |
| 6841                              | 5,899                       | 0,800                             | 36,152   | 0,000    | 0,000                   | 1,526                        | 2,895                        | 3,866                        | 4,587                        | 5,025                        |
| 7322                              | 6,240                       | 0,800                             | 35,937   | 0,000    | 0,000                   | 1,508                        | 2,747                        | 3,644                        | 4,343                        | 4,806                        |
| 7803                              | 6,580                       | 0,800                             | 35,745   | 0,000    | 0,000                   | 1,484                        | 2,585                        | 3,426                        | 4,098                        | 4,585                        |



SANDRA ALLEGUE GARCÍA  
CUADERNO 4

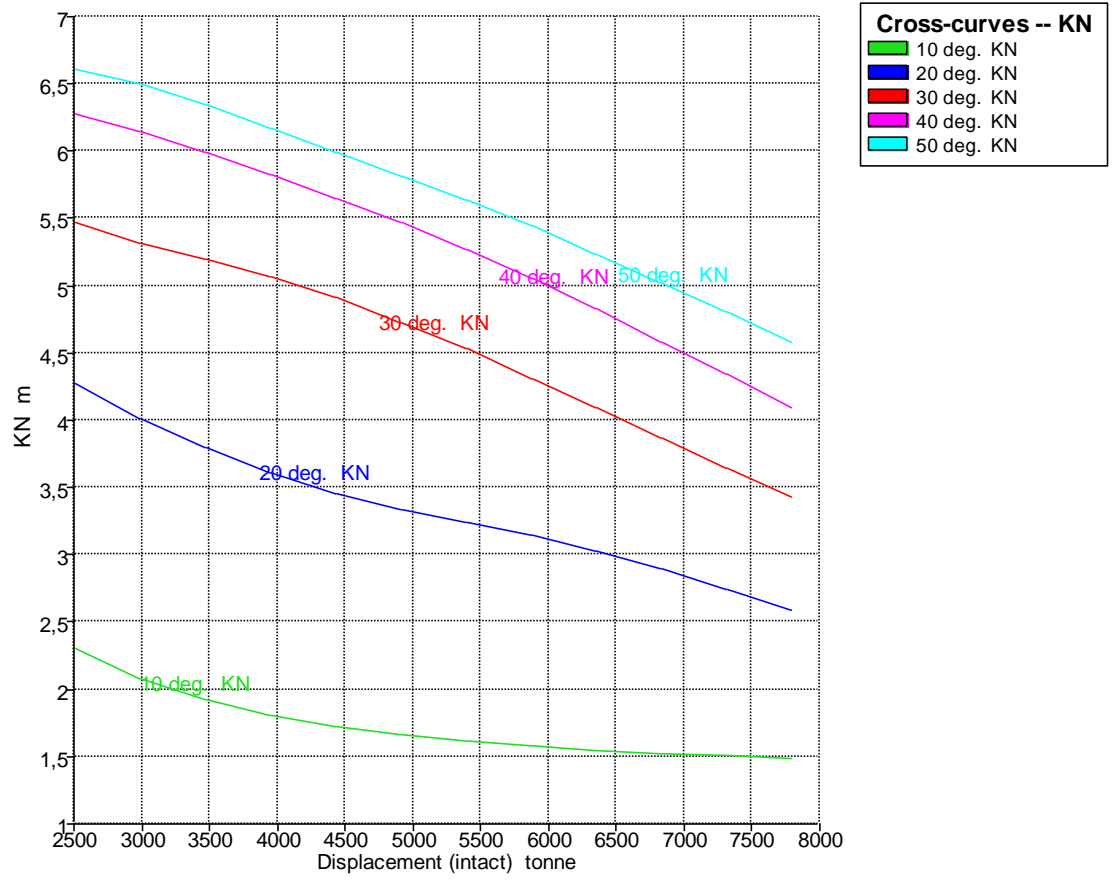

### 3.2 TRIMADO 0 M

| Displacement (intact) tonne | Draft Amidships m | Trim (+ve by stern) m | LCG m  | TCG m | Assumed VCG m | KN 10,0 deg. Starb. | KN 20,0 deg. Starb. | KN 30,0 deg. Starb. | KN 40,0 deg. Starb. | KN 50,0 deg. Starb. |
|-----------------------------|-------------------|-----------------------|--------|-------|---------------|---------------------|---------------------|---------------------|---------------------|---------------------|
| 2512                        | 2,572             | 0,000                 | 39,319 | 0,000 | 0,000         | 2,262               | 4,188               | 5,372               | 6,180               | 6,526               |
| 2993                        | 2,980             | 0,000                 | 39,125 | 0,000 | 0,000         | 2,043               | 3,942               | 5,231               | 6,069               | 6,439               |
| 3474                        | 3,379             | 0,000                 | 38,905 | 0,000 | 0,000         | 1,891               | 3,733               | 5,118               | 5,935               | 6,312               |
| 3955                        | 3,770             | 0,000                 | 38,678 | 0,000 | 0,000         | 1,780               | 3,557               | 5,002               | 5,790               | 6,153               |
| 4436                        | 4,155             | 0,000                 | 38,455 | 0,000 | 0,000         | 1,698               | 3,413               | 4,862               | 5,632               | 5,985               |
| 4917                        | 4,531             | 0,000                 | 38,212 | 0,000 | 0,000         | 1,638               | 3,300               | 4,700               | 5,460               | 5,817               |
| 5398                        | 4,900             | 0,000                 | 37,963 | 0,000 | 0,000         | 1,593               | 3,213               | 4,520               | 5,274               | 5,644               |
| 5879                        | 5,260             | 0,000                 | 37,703 | 0,000 | 0,000         | 1,561               | 3,131               | 4,324               | 5,073               | 5,461               |
| 6360                        | 5,614             | 0,000                 | 37,439 | 0,000 | 0,000         | 1,536               | 3,030               | 4,119               | 4,858               | 5,268               |
| 6841                        | 5,961             | 0,000                 | 37,172 | 0,000 | 0,000         | 1,518               | 2,910               | 3,907               | 4,632               | 5,066               |
| 7322                        | 6,304             | 0,000                 | 36,903 | 0,000 | 0,000         | 1,505               | 2,775               | 3,695               | 4,396               | 4,855               |
| 7803                        | 6,646             | 0,000                 | 36,650 | 0,000 | 0,000         | 1,495               | 2,626               | 3,484               | 4,158               | 4,640               |

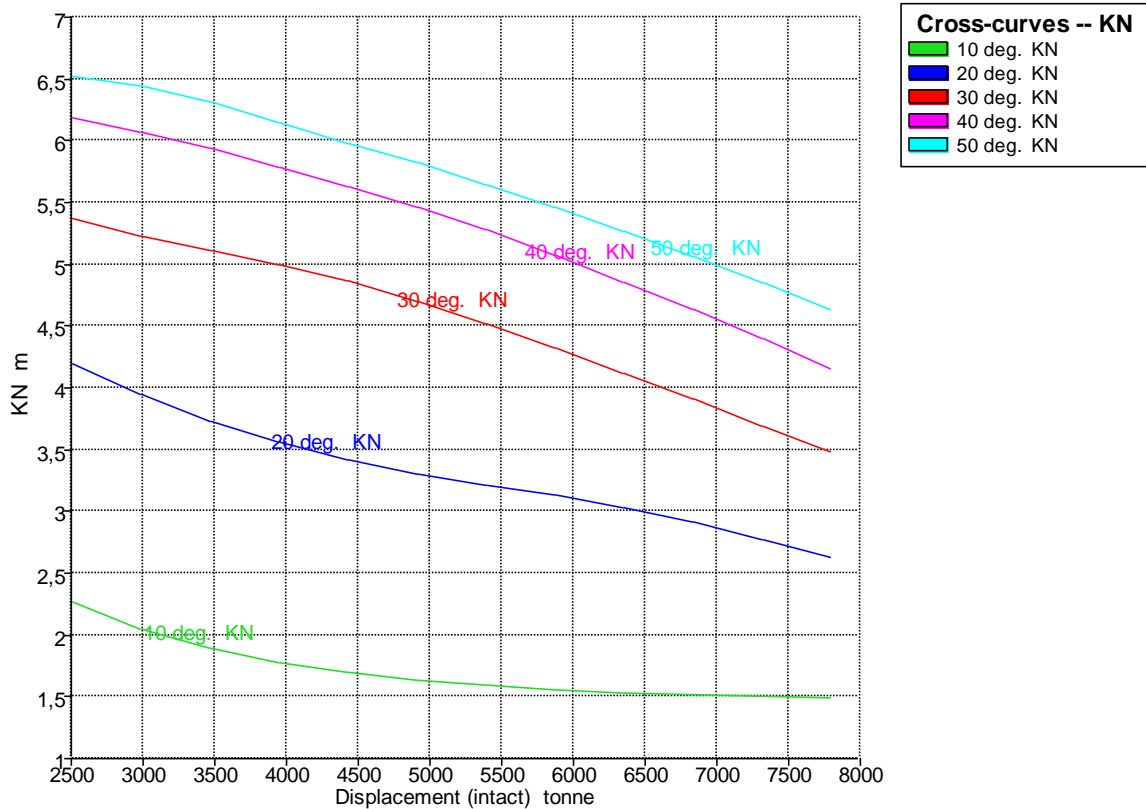

### 3.3 TRIMADO - 0,8 M

| Displacement (intact) tonne | Draft Amidships m | Trim (+ve by stern) m | LCG m  | TCG m | Assumed VCG m | KN 10,0 deg. Starb. | KN 20,0 deg. Starb. | KN 30,0 deg. Starb. | KN 40,0 deg. Starb. | KN 50,0 deg. Starb. |
|-----------------------------|-------------------|-----------------------|--------|-------|---------------|---------------------|---------------------|---------------------|---------------------|---------------------|
| 2512                        | 2,578             | -0,800                | 40,958 | 0,000 | 0,000         | 2,224               | 4,104               | 5,282               | 6,076               | 6,438               |
| 2993                        | 2,992             | -0,800                | 40,596 | 0,000 | 0,000         | 2,011               | 3,871               | 5,152               | 5,993               | 6,374               |
| 3474                        | 3,397             | -0,800                | 40,258 | 0,000 | 0,000         | 1,861               | 3,672               | 5,046               | 5,882               | 6,272               |
| 3955                        | 3,793             | -0,800                | 39,936 | 0,000 | 0,000         | 1,755               | 3,506               | 4,935               | 5,752               | 6,133               |
| 4436                        | 4,182             | -0,800                | 39,624 | 0,000 | 0,000         | 1,676               | 3,371               | 4,811               | 5,607               | 5,975               |
| 4917                        | 4,565             | -0,800                | 39,335 | 0,000 | 0,000         | 1,618               | 3,266               | 4,667               | 5,447               | 5,813               |
| 5398                        | 4,940             | -0,800                | 39,039 | 0,000 | 0,000         | 1,575               | 3,184               | 4,504               | 5,273               | 5,647               |
| 5879                        | 5,306             | -0,800                | 38,740 | 0,000 | 0,000         | 1,545               | 3,108               | 4,327               | 5,084               | 5,474               |
| 6360                        | 5,666             | -0,800                | 38,440 | 0,000 | 0,000         | 1,525               | 3,020               | 4,137               | 4,881               | 5,291               |
| 6841                        | 6,019             | -0,800                | 38,140 | 0,000 | 0,000         | 1,511               | 2,915               | 3,939               | 4,665               | 5,097               |
| 7322                        | 6,368             | -0,800                | 37,841 | 0,000 | 0,000         | 1,502               | 2,794               | 3,737               | 4,440               | 4,895               |
| 7803                        | 6,709             | -0,800                | 37,564 | 0,000 | 0,000         | 1,493               | 2,660               | 3,535               | 4,210               | 4,687               |

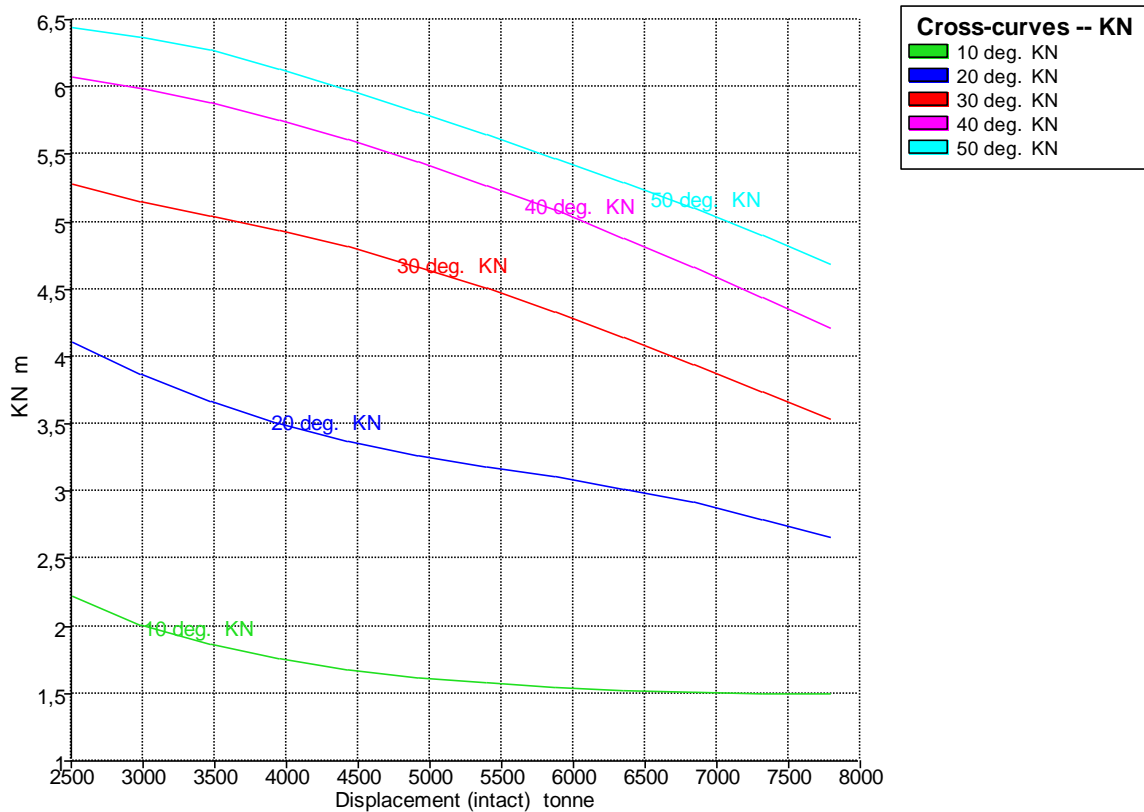

## 4 ZONA ESTANCA Y PUNTOS DE INUNDACIÓN PROGRESIVA

---

Los puntos de inundación progresiva son puntos en la obra muerta del buque y por encima de la cubierta de francobordo en los cuales se puede dar un embarque de agua.

Los puntos de inundación progresiva se encuentran en la cubierta 5 y coinciden con unas puertas no estancas, siendo las coordenadas:

$$x_1 = 61,8 \text{ m}$$

$$y_1 = 2,55 \text{ m}$$

$$z_1 = 13,25 \text{ m}$$

$$x_2 = 63,2 \text{ m}$$

$$y_2 = 3,84 \text{ m}$$

$$z_2 = 13,25 \text{ m}$$

Tanto la zona estanca como los puntos de inundación progresiva del buque proyecto se adjuntan como Anexo 1.

## 5 COMPARTIMENTADO

---

Para hacer todo el compartimentado del buque proyecto se usarán los apuntes de la asignatura de Proyectos del Buque.

### 5.1 COMPARTIMENTADO LONGITUDINAL

#### 5.1.1 Separación de cuadernas

En este apartado se determinará la distancia entre cuadernas a lo largo del buque:

- La separación entre las cuadernas en el pique de proa y en el pique de popa será de 600 mm.
- En el resto del buque la separación entre cuadernas será de 700 mm.

Además, también se expondrá la distribución longitudinal de las bulárcamas:

- Se colocará una bulárcama por tres cuatro cuadernas.

#### 5.1.2 Pique de popa

Para poder colocar el pique de popa se indica que ha de tener una longitud mínima de 4m y una máxima de 7/8 m desde la perpendicular de popa.

Utilizando el buque base y comparándola con los apuntes se utiliza un valor de **7,2 m**.

El pique de popa tendrá 12 cuadernas.

#### 5.1.3 Espacios de bodega

A continuación de pique de popa existirá dos espacios de bodegas, extrapolando desde el buque base se obtiene una longitud de 7,76 m y 14,01 m.

Ajustando las medidas para que coincidan con las cuadernas será de **8,40 m y 14 m**.

En el primer espacio de bodegas habrá 12 cuadernas y en el segundo habrá 20 cuadernas.

#### 5.1.4 Cámara de bombas

El espacio de la cámara de bombas tendrá que tener una longitud mínima de 3 o 4 m. Utilizando el buque base y extrapolando los datos al buque proyecto se observa que tiene una longitud de **19,60 m**.

La cámara de bombas tendrá 28 cuadernas

#### 5.1.5 Cámara de máquinas

La cámara de máquinas se dimensionará, principalmente, a partir de la longitud de los motores principales.

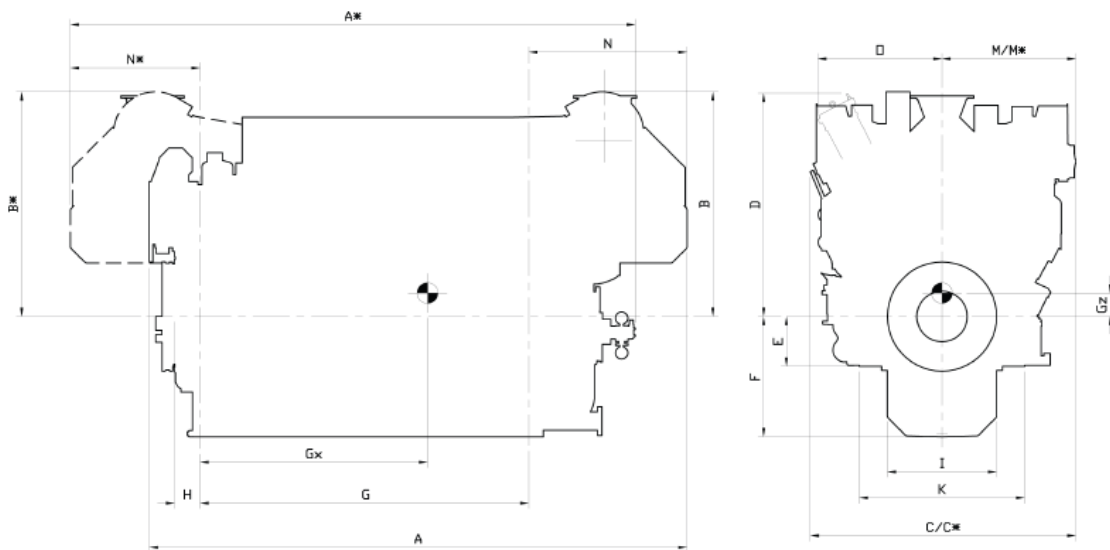

**Fig 1-2 V-engines (DAAE034757b)**

| Engine  | A*   | A    | B*   | B    | C*   | C    | D    | E   | F <sub>wet</sub> | F <sub>dry</sub> | G    |
|---------|------|------|------|------|------|------|------|-----|------------------|------------------|------|
| W 12V26 | 5442 | 5314 | 2034 | 2034 | 2552 | 2602 | 2060 | 460 | 1110             | 800              | 3035 |
| W 16V26 | 6223 | 6025 | 2151 | 2190 | 2489 | 2763 | 2060 | 460 | 1110             | 800              | 3875 |

El motor principal tiene una longitud de 5,314 m. A partir de este valor de le añadirán 6 metros hacia popa y 4 metros por proa, quedando un total de:

$$lcm = 5,314 + 6 + 4 \rightarrow lcm = 15,314 \text{ m}$$

La longitud mínima de la cámara de máquinas será por tanto de 15,314 m.

Por lo que, ajustando las medidas, la longitud de la cámara de máquinas será de **15,40 m**.

La cámara de máquinas tendrá 22 cuadernas.

### 5.1.6 Local del propulsor de proa

La longitud del local del propulsor de proa mínima será de 4 o 5 m o 3 veces el diámetro del propulsor. En proa habrá dos propulsores, por lo que la longitud será de:

$$lpp = 3 \cdot 2 \cdot 1850 = 11100 \text{ mm} \rightarrow lpp = 11,1 \text{ m}$$

Ajustando las medidas se obtienen una longitud de **11,20 m**.

El local del propulsor de proa tendrá 16 cuadernas.

### 5.1.7 Pique de proa

Mediante este apartado se fijará la distancia a la que se ha de situar el mamparo de colisión. Para determinarlo, se utilizará el convenio SOLAS, Capítulo II-1, Parte B, Regla 11:

*“2. Se instalará un mamparo de colisión que será estanco hasta la cubierta de francobordo. Este mamparo estará situado a una distancia a popa de la perpendicular de proa no inferior*

*al 5 por ciento de la eslora del buque o a 10 m si esta segunda magnitud es menor y, salvo cuando la Administración permita otra cosa, dicha distancia no será superior al 8 por ciento de la eslora del buque.”*

Debido a que el buque proyecto consta de un bulbo de proa:

*“3. Cuando cualquiera parte del buque que quede debajo de la flotación se prolongue por delante de la perpendicular de proa, como por ejemplo ocurre con una proa de bulbo, las distancias estipuladas en el párrafo 2 se medirá desde un punto situado:*

*.1 a mitad de dicha prolongación*

*.2 a una distancia igual al 1,5 por ciento de la parte de la eslora del buque que quede por delante de la perpendicular de proa; o*

*.3 a una distancia de 3m por delante de la perpendicular de proa.*

*Se tomará, de estas medidas, la menor.”*

Por lo que primero se calculará la distancia a la que estará situado el mamparo de colisión:

$$\text{Distancia mínima} = 5\% \text{ de } L_{pp} = 0,05 \cdot 78,58 \rightarrow \text{Distancia mínima} = 3,93 \text{ m}$$

Que es menor de 10 m, por lo que se usará esta distancia.

$$\text{Distancia máxima} = 8\% \text{ de } L_{pp} = 0,08 \cdot 78,58 \rightarrow \text{Distancia máxima} = 6,29 \text{ m}$$

Ahora, se procederá a calcular desde donde se debe medir la distancia a la cual colocar el mamparo de colisión:

$$\text{Punto 1} = 0,5 \text{ de la protuberancia} = 0,5 \cdot 4 \rightarrow \text{Punto 1} = 2 \text{ m}$$

$$\text{Punto 2} = 1,5\% \text{ de eslora por delante de la PPr} = 0,015 \cdot 78,58$$

$$\text{Punto 2} = 1,18 \text{ m}$$

$$\text{Punto 3} = 3 \text{ m}$$

El punto escogido sería el 2 ya que es el menor.

Debido a las condiciones del proyecto para la colocación de las cuadernas, si se utiliza este punto el mamparo de proa no coincidirá con una cuaderna, por lo que se toma como punto de medición 1,63 m (a proa de a perpendicular de proa).

Por lo que la posición del mamparo de colisión será de **5,40 m**, medido hacia popa.

El pique de proa tendrá 9 cuadernas.

## **5.2 COMPARTIMENTADO TRANSVERSAL**

El compartimentado transversal define la posición de los mamparos longitudinales a lo largo de la manga del buque. Como no es un buque de pasaje no deber cumplir ningún requerimiento especial, a parte del doble casco.

El doble casco se situará utilizando como guía la *Resolution MSC.235(82). Adoption of de guidelines for the design and construction of Offshore Supply Vessels, 2006* la extensión del doble casco será de 760 mm, esta medida se tomará desde el costado hacia el centro a nivel del calado de verano.

Se tomará esta extensión como distancia mínima, por lo que el doble casco será de **1 m**, para así poder cumplir con los criterios constructivos.

### 5.3 COMPARTIMENTADO VERTICAL

#### 5.3.1 Doble fondo

La altura del doble fondo se determinará mediante la Sociedad de Clasificación DNV·GL en la Pt.3, Ch.2, Section 2.3.

El reglamento define la altura del doble fondo como:

$$hDB = \frac{B}{20}$$

La altura no podrá ser mayor de 2 m y no podrá ser menor de 1,5 m.

Por lo que, la altura mínima del doble fondo será de 0,96 m.

Por lo que la altura del doble fondo será de **1,5 m**.

#### 5.3.2 Cubiertas

Por debajo de la cubierta principal habrá un entrepuente de 3 m de altura que se extiende desde el mamparo a proa del pique de popa hasta el mamparo de popa del pique de proa, discontinuo en la cámara de máquinas para poder albergar al motor.

La cubierta principal tendrá una altura de 2,5 m.

Por encima de la cubierta principal existen tres cubiertas de habitación, dos de ellas de 2,5 m (cubierta A y B) y otra de 3 m (cubierta C). Por último, se encuentra el puente de 2,5 m de altura.

### 5.4 RESUMEN DEL COMPARTIMENTADO

| <b>COMPARTIMENTADO LONGITUDINAL</b> |                     |                               |
|-------------------------------------|---------------------|-------------------------------|
| <i>Espacio</i>                      | <i>Longitud (m)</i> | <i>Extensión en cuadernas</i> |
| Pique de popa                       | 7,2                 | C0 a C12                      |
| Espacio de bodega 1                 | 8,40                | C12 a C24                     |
| Espacio de bodega 2                 | 14                  | C24 a C44                     |
| Cámara de bombas                    | 19,60               | C44 a C72                     |
| Cámara de máquinas                  | 15,40               | C72 a C94                     |
| Local del propulsor de proa         | 11,20               | C94 a C110                    |
| Pique de proa                       | 5,40                | C110 a C119                   |

| <b>COMPARTIMENTADO TRANSVERSAL</b> |                   |
|------------------------------------|-------------------|
| <i>Espacio</i>                     | <i>Altura (m)</i> |
| Doble casco                        | 1                 |



| <b>COMPARTIMENTADO VERTICAL</b> |                          |
|---------------------------------|--------------------------|
| <b><i>Espacio</i></b>           | <b><i>Altura (m)</i></b> |
| Doble fondo (Cubierta 1)        | 1,5                      |
| Entrepunte (Cubierta 2)         | 3                        |
| Cubierta principal (Cubierta 3) | 2,5                      |
| Cubierta A (Cubierta 4)         | 2,5                      |
| Cubierta B (Cubierta 5)         | 2,5                      |
| Cubierta C (Cubierta 6)         | 3                        |
| Puente (Cubierta 7)             | 2,5                      |

Se adjuntan los planos obtenidos como Anexo 2.

## 6 TANQUES Y CAPACIDADES

En este apartado se calcularán todos los tanques y las capacidades necesarias de cada uno siguiendo la normativa correspondiente en cada caso.

### 6.1 CONSUMOS

Aunque se ha hecho una estimación de los consumos requeridos en el Cuaderno 1, se volverán a realizar todos los cálculos necesarios ya que ahora se dispone de más información.

#### 6.1.1 Combustible

El cálculo de combustible se realizará mediante los datos que da el fabricante en el catálogo, que en este caso es Wärtsilä. El buque proyecto consta de un motor diésel para la propulsión del buque y un motor auxiliar LNG cuando el buque se encuentra en puerto.

El motor Diesel es el Wärtsilä W 12V26 de 4008 kW y como motor de puerto se ha elegido el GS12R-MPTK de Mitsubishi de 722 kW.

Como ya se ha expuesto anteriormente el buque, según RPA, consta de posicionamiento dinámico DP3, por lo que tiene una redundancia máxima en caso de falla de los motores para que el buque pueda seguir con todos los procesos. Es decir, si fallan dos motores o los otros dos tienen que dar la suficiente potencia al buque.

Por esto se dimensionan los motores al 50 % ya que es de la forma que más consumen los motores, la otra opción es dimensionar como si solo existieran dos motores al 100 %, pero de esta manera es menos exigente la cantidad de combustible.

$$V_{DO} = \frac{200,9 \text{ g}}{\text{kW} \cdot \text{h}} \cdot 4008 \text{ kW} \cdot \frac{6000 \text{ millas}}{13 \text{ nudos}} \cdot 4 \text{ generadores} \cdot \frac{1 \text{ tn}}{10^6 \text{ g}} \cdot \frac{1 \text{ m}^3}{0,89 \text{ t}} \cdot 0,5 = 836 \text{ m}^3$$

$$V_{LNG} = \frac{7387 \text{ kJ}}{\text{kW} \cdot \text{h}} \cdot 722 \text{ kW} \cdot 5 \text{ días} \cdot 24 \text{ horas} \cdot \frac{\text{kg}}{52.000 \text{ kJ}} \cdot \frac{1 \text{ tn}}{10^3 \text{ kg}} \cdot \frac{1 \text{ m}^3}{0,45 \text{ t}} = 28 \text{ m}^3$$

#### 6.1.2 Diesel oíl de uso diario

El buque dispondrá de dos tanques de uso diario, situado en la cámara de máquinas, para abastecer a los motores generadores directamente.

Para hacer el cálculo del combustible necesario se seguirá la Product Guide del motor en la que indica que tendrá que haber suficiente combustible para abastecer al motor durante 8 horas al 50 % del MCR:

$$V_{DO} = \frac{200,9 \text{ g}}{\text{kW} \cdot \text{h}} \cdot 4008 \text{ kW} \cdot 8 \text{ horas} \cdot 4 \text{ generadores} \cdot \frac{1 \text{ tn}}{10^6 \text{ g}} \cdot \frac{1 \text{ m}^3}{0,89 \text{ t}} \cdot 0,5 = 14,48 \text{ m}^3$$

Esta será la capacidad de tanque, por lo que el volumen total será de 28,96 m<sup>3</sup>.

#### 6.1.3 Diesel oíl de sedimentación

El buque dispondrá de un tanque de sedimentación, situado en la cámara de máquinas, a continuación del tanque de Diesel oíl de uso diario.

Para hacer el cálculo de la capacidad necesaria se seguirá la Product Guide del motor en la que se indica que indica que tiene que almacenar la cantidad para 24 horas estando el motor al 50 % del MCR:

$$V_{DO} = \frac{200,9 \text{ g}}{\text{kW} \cdot \text{h}} \cdot 4008 \text{ kW} \cdot 24 \text{ horas} \cdot 4 \text{ generadores} \cdot \frac{1 \text{ tn}}{10^6 \text{ g}} \cdot \frac{1 \text{ m}^3}{0,89 \text{ t}} \cdot 0,5 = 43,43 \text{ m}^3$$

#### 6.1.4 Aceite de lubricación

El aceite lubricante del motor viene dado por el fabricante del motor.

En el catálogo especifica que se necesitan 0,4 g/kWh de aceite por cada motor, por lo que el aceite total necesario, para 4 motores, será (añadiendo un margen del 10%):

$$V_{AC} = \frac{0,4 \text{ g}}{\text{kW} \cdot \text{h}} \cdot 4008 \text{ kW} \cdot \frac{6000 \text{ millas}}{13 \text{ nudos}} \cdot 4 \text{ generadores} \cdot \frac{1 \text{ tn}}{10^6 \text{ g}} \cdot \frac{1 \text{ m}^3}{0,92 \text{ t}} \cdot 1,1 = 3,54 \text{ m}^3$$

Por otra, parte el fabricante también recomienda que la capacidad del tanque de aceite de lubricación sea de 2,2 m<sup>3</sup> por cada generador, por lo que se usará esta segunda cantidad debido a que es más alta.

Por lo que, la capacidad de los tanques de aceite lubricante debe ser de **9 m<sup>3</sup>**.

#### 6.1.5 Agua técnica

En los buques Supply el agua técnica también incluye el agua de perforación de las plataformas petrolíferas utilizada para lubricar/refrigerar el taladro perforador.

Debido a que el buque debe llevar una cantidad bastante considerable de agua técnica debido a lo expuesto anteriormente se usarán los tanques de lastre para transportar el agua técnica.

Por lo tanto, será la capacidad del agua de lastre lo que delimitará la cantidad de agua técnica que se podrá transportar.

#### 6.1.6 Aguas negras/grises

Para determinar la cantidad de aguas negras y grises almacenadas se utilizará la norma UNE-EN ISO 15749-1:2004, mediante la siguiente tabla se observa que la cantidad de agua de desecho generada:

Tabla 2  
Cantidad mínima de agua de desecho

| Tipo de buque   | Cantidad mínima de agua de desecho por persona y día en litros |                       |                  |                       |
|---|--|-----------------------|------------------|-----------------------|
|   | Planta sin vacío   |                       | Planta con vacío |                       |
|   | Aguas negras   | Aguas negras y grises | Aguas negras     | Aguas negras y grises |
| Buques de pasaje  | 70   | 230                   | 25               | 185                   |
| Buques de alta mar exceptuando los de pasaje  | 70   | 180                   | 25               | 135                   |
| Los buques costeros pueden conservar los valores recomendados por las autoridades responsables.   |  |                       |                  |                       |
| NOTA – Estos valores son los recomendados. Hay que considerar las posibles variaciones debidas a los reglamentos nacionales o a las recomendaciones de las sociedades de clasificación. |  |                       |                  |                       |

Como se indica en el presente reglamento, las aguas grises y negras son aguas que se podrán evacuar, pero antes de esta evacuación serán tratadas debidamente en una planta de tratamiento de aguas residuales.

Por lo tanto, según la tabla, en los buques de alta mar, exceptuando los de pasaje, se aconseja que la cantidad mínima de desecho sea 135 litros por persona y por día.

El cálculo se realizará para un periodo de 3 días, ya que a continuación se procederá a hacer el debido tratamiento y a su expulsión:

$$Vag. grises = 3 \text{ días} \cdot \frac{110 \text{ l}}{\text{día} \cdot \text{persona}} \cdot 35 \text{ personas} \cdot \frac{1 \text{ m}^3}{1000 \text{ l}} = 11,55 \text{ m}^3$$

$$Vag. negras = 3 \text{ días} \cdot \frac{25 \text{ l}}{\text{día} \cdot \text{persona}} \cdot 35 \text{ personas} \cdot \frac{1 \text{ m}^3}{1000 \text{ l}} = 2,63 \text{ m}^3$$

Por lo que el volumen de almacenamiento del tanque será de **14,18 m<sup>3</sup>**.

### 6.1.7 Agua potable

Para el cálculo del agua potable se calculará la cantidad de aguas grises y negras que se generan en total, con la ayuda de la tabla anterior. Esta cantidad será la cantidad mínima que se tendrá de agua dulce:

$$Vag. grises = \frac{6000}{13 \cdot 24} \text{ días} \cdot \frac{110 \text{ l}}{\text{día} \cdot \text{persona}} \cdot 35 \text{ personas} \cdot \frac{1 \text{ m}^3}{1000 \text{ l}} = 74,04 \text{ m}^3$$

$$Vag. negras = \frac{6000}{13 \cdot 24} \text{ días} \cdot \frac{25 \text{ l}}{\text{día} \cdot \text{persona}} \cdot 35 \text{ personas} \cdot \frac{1 \text{ m}^3}{1000 \text{ l}} = 16,83 \text{ m}^3$$

Dando una cantidad total de 90,87 m<sup>3</sup>.

Comparando este cálculo con el cálculo según la norma UNE-EN ISO 15748-2:2002, utilizando la tabla incluida en el Anexo A:

**Tabla A.1**  
Valores guía para el consumo de agua potable en litros por persona/cama y día

| Tipo de buque       |                          | Grupo de personas embarcado | Consumo de agua cuando esté equipado con |                           |
|---------------------|--------------------------|-----------------------------|--|---------------------------|
|                     |                          |                             | sistema de aseos de gravedad             | sistema de aseos de vacío |
| Buque de alta mar   | Carguero                 | Tripulante/cama             | 220 l                                    | 175 l                     |
|                     | Buque de pasaje          | Pasajero/cama               | 270 l                                    | 225 l                     |
|                     | Crucero de lujo          | Pasajero/cama               | –  | 275 l                     |
|                     | Trasbordador con cabinas | Pasajero/cama               | 205 l <sup>a</sup>                       | 160 l <sup>a</sup>        |
|                     |                          | Pasajero sin cama           | 100 l                                    | 55 l                      |
|                     | Trasbordador sin cabinas | Pasajero sin cama           | 150 l                                    | 105 l                     |
| Tripulante sin cama |                          | 100 l                       | 55 l                                     |                           |

Para el cálculo se utilizará el del buque carguero, con sistemas de aseos de vacío, siendo los litros por tripulante/cama de 175 l.

Siguiendo la RPA el buque se proyecta para 35 personas, se aplicará además un margen del 10 %. Por lo tanto, el volumen de agua dulce necesario será de:

$$V_{ag. potable} = \frac{6000}{13 \cdot 24} \text{ días} \cdot \frac{175 \text{ l}}{1 \text{ día}} \cdot \frac{1 \text{ m}^3}{1000 \text{ l}} \cdot 35 \text{ personas} \cdot 1,1 = 129,57 \text{ m}^3$$

Por lo tanto, se usará el valor aproximado de **130 m<sup>3</sup>**, debido a que el segundo cálculo da un valor menos restrictivo por si surge algún tipo de avería o fuga.

### 6.1.8 Aceite usado y lodos (residuos de hidrocarburos)

En este caso, el único aceite usado que hay que almacenar es el que consume el motor para su lubricación. Solo sería necesario si ocurre alguna avería en el sistema, debido a que el sistema de lubricación del motor es un circuito cerrado y su vaciado, normalmente, solo se produce en puerto.

Por lo tanto, para hacer este cálculo se tomará la cantidad anteriormente calculada de 9 m<sup>3</sup> (volumen necesario de aceite para lubricación de todos los motores). Se tendrá en cuenta que no se recuperará todo el volumen de aceite debido a la evaporación de una parte debido a la fricción y a cualquier tipo de pérdida que se pueda producir, por lo que se tendrá en cuenta que se recuperará el 50 % del aceite:

$$V_{ac. usado} = 9 \cdot 0,5 = 4,5 \text{ m}^3$$

Este aceite se almacenará en el tanque de lodos (residuos de hidrocarburos) que se calcula a continuación.

Para hacer el cálculo del almacenamiento de lodos se utilizará el convenio MARPOL, siguiendo la regla 12 del Anexo 1:

#### Regla 12

*Tanques para residuos de hidrocarburos (fangos)*

1 Todos los buques de arqueo igual o superior a 400 estarán provistos de un tanque o tanques de capacidad adecuada, según el tipo de máquinas y la duración del viaje, para recibir los residuos de hidrocarburos (fangos) que no puedan tratarse de otra forma con arreglo a las disposiciones del presente Anexo.

Para calcular la capacidad mínima de los tanques se utilizará la fórmula indicada en la interpretación 16 para buques que no lleven agua de lastre en los tanques de combustible líquido:

$$V_1 = K_1 \cdot C \cdot D$$

Siendo:

K<sub>1</sub>: 0,01 para buques en los que se purifique fueloil pesado destinado a la máquina principal, o 0,005 para los buques en que se utilice Diesel oíl o fueloil pesado que no haya de ser purificado antes de su uso.

Como el buque proyecto usa Diesel oíl se utilizará el valor de 0,005.

C: consumo diario de Diesel oíl (toneladas), 31,37 t/día.

D: duración del viaje entre puertos en los que puedan descargarse fangos en tierra (días). A falta de datos precisos, se utilizará la cifra de 30 días.

El buque proyecto tiene una autonomía de 6000 millas, que corresponde a 19 días.

$$V_1 = 0,005 \cdot 31,37 \cdot 19 = 2,98 \text{ m}^3$$

## 6.2 TANQUES DE LASTRE

Aunque en este cuaderno y en cuadernos posteriores solo se habla de tanques de lastre estos tanques pueden transportar lastre como agua técnica. Como agua técnica se engloba tanto el agua que consume el buque como el agua que se transporta a la plataforma que es usada en el proceso de perforación.

Estos tanques son los que mayor capacidad total tienen ya que debido a las condiciones de carga tan diferentes en las que se puede encontrar el buque hay momentos en los que se hace necesario utilizar una gran cantidad de volumen de lastre, así como hay momentos en los que solo se transporte el agua técnica necesaria para el consumo del buque proyecto o de la plataforma.

En el Cuaderno 5 se analiza y se observa la necesidad de todos los tanques de lastre aquí definidos, el buque contará con 22 tanques de lastre/agua técnica cuyas capacidades se encuentran definidas en el listado de tanques.

## 6.3 TANQUES DE CEMENTO

Estos tanques son los más característicos de este tipo de buques ya que tienen un tipo de forma característica:

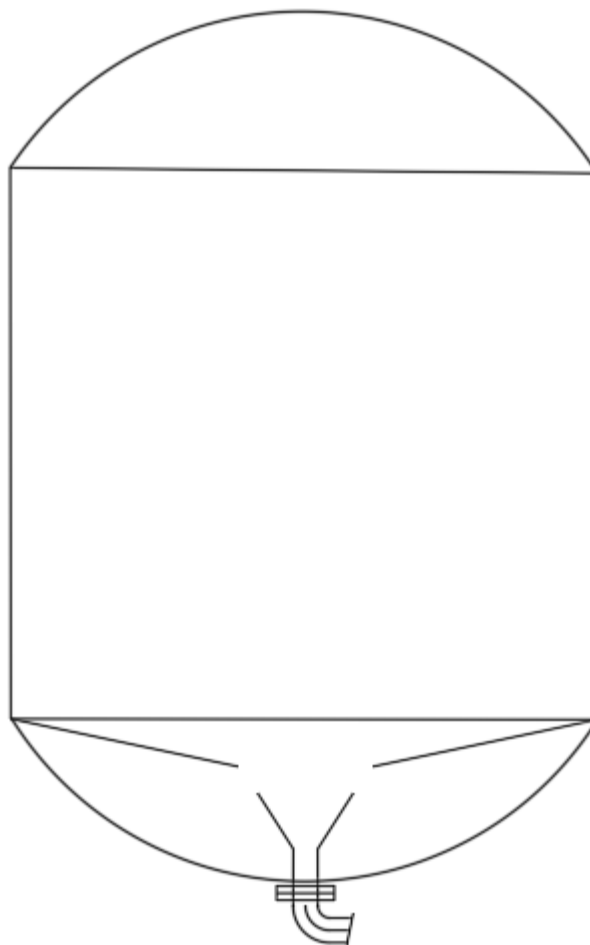

Este cemento es utilizado para revestir las paredes y protegerlas de las filtraciones que puedan existir de agua y gas que se originan durante la perforación.

El buque contará con 3 tanques de cemento con una capacidad total de unos 160 m<sup>3</sup>.

#### **6.4 TANQUES DE BARRO DE PERFORACIÓN Y RESIDUOS DE HIDROCARBUROS**

Esos tanques tienen forma cilíndrica y en ellos se transporta el barro utilizado en el proceso de perforación usado para que no existan desprendimiento mientras se realiza el proceso para poder conseguir el petróleo sin que existan peligro de derrumbe.

Además de alojar este producto, como el buque puede operar en algún momento recogiendo hidrocarburos derramados en el mar (lucha contra la contaminación, estos tanques también servirán para recoger los hidrocarburos y alojarlos hasta la llegada al puerto.

El buque contará con 4 tanques de este tipo con una capacidad total de 380 m<sup>3</sup>.

#### **6.5 TANQUES DE METANOL Y XILENO**

Estos tanques tienen forma paralelepípeda líquidos tóxicos como el metanol y el xileno.

El buque contra con dos tanques de este tipo con una capacidad de 207 m<sup>3</sup>.

#### **6.6 TANQUES DE PRODUCTOS ESPECIALES Y BASE OÍL**

Estos tanques tienen forma paralelepípeda y pueden contener productos diversos que puedan generarse en la plataforma.

El buque contra con dos tanques de este tipo con una capacidad de 207 m<sup>3</sup>.

## 6.7 TABLA RESUMEN DE CAPACIDADES

En este apartado se mostrarán todas las capacidades calculadas hasta este momento:

| Tanque                    | Volumen en m <sup>3</sup> |
|---------------------------|---------------------------|
| Diesel oíl total          | 836                       |
| Diesel oíl uso diario (2) | 28,96                     |
| Diesel oíl sedimentación  | 43,43                     |
| LNG                       | 28                        |
| Aceite de lubricación     | 1,90                      |
| Aguas negras y grises     | 23,63                     |
| Agua potable              | 130                       |
| Aceite usado              | 4,50                      |
| Lodos                     | 2,98                      |

## 6.8 LISTADO DE TANQUES Y COMPROBACIÓN DE CAPACIDADES. CARGA ÚTIL

Una vez finalizados todos los cálculos iniciales se han situado todos los tanques atendiendo a:

1. Capacidades de los consumos.
2. Distribución del buque base *Rem Supporter*.

Se ha decidido hacer la distribución a través de esos criterios ya que el buque proyecto va a tener una distribución similar al buque base, siempre adaptando las medidas a la geometría del presente buque proyecto y haciendo que no interfiera en ningún momento con otros servicios esenciales del buque.

Finalmente, después de haber introducido todos los tanques en el programa Maxsurf se han obtenido las siguientes capacidades:

| Tanque                        | Volumen calculado en m <sup>3</sup> | Volumen real en m <sup>3</sup> |
|-------------------------------|-------------------------------------|--------------------------------|
| Diesel oíl total              | 836                                 | 1.249,94                       |
| Diesel oíl uso diario (2)     | 28,96                               | 29,40                          |
| Diesel oíl sedimentación      | 43,43                               | 43,68                          |
| LNG                           | 28                                  | 36,13                          |
| Aceite de lubricación         | 9                                   | 9,45                           |
| Agua técnica/lastre           | -                                   | 1.916,38                       |
| Cemento                       | -                                   | 157,02                         |
| Barro de perforación          | -                                   | 380,11                         |
| Metanol/xileno                | -                                   | 206,70                         |
| Productos especiales/base oíl | -                                   | 206,70                         |



SANDRA ALLEGUE GARCÍA  
CUADERNO 4

|                       |       |        |
|-----------------------|-------|--------|
| Aguas negras y grises | 14,18 | 16,763 |
| Agua potable          | 130   | 469,29 |
| Aceite usado          | 4,50  | 6,3    |
| Lodos                 | 2,98  | 3,15   |

A continuación, se muestra una lista de todos los tanques del buque proyecto:

| <b>Tanque</b> | <b>Volumen,<br/>m3</b> |
|---------------|------------------------|
| CEM 1 BR      | 52,339                 |
| CEM 1 CE      | 52,339                 |
| CEM 1 ER      | 52,339                 |
| <b>TOTAL</b>  | <b>157,017</b>         |

| <b>Tanque</b> | <b>Volumen,<br/>m3</b> |
|---------------|------------------------|
| MUD 1 BR      | 66,933                 |
| MUD 1 ER      | 66,933                 |
| MUD 2 BR      | 123,122                |
| MUD 2 ER      | 123,122                |
| <b>TOTAL</b>  | <b>380,11</b>          |

| <b>Tanque</b> | <b>Volumen,<br/>m3</b> |
|---------------|------------------------|
| DO/BO 1 BR    | 66,933                 |
| DO/BO 1 ER    | 66,933                 |
| <b>TOTAL</b>  | <b>133,866</b>         |

| <b>Tanque</b> | <b>Volumen,<br/>m3</b> |
|---------------|------------------------|
| MET BR        | 103,35                 |
| MET ER        | 103,35                 |
| <b>TOTAL</b>  | <b>206,7</b>           |

| <b>Tanque</b> | <b>Volumen,<br/>m3</b> |
|---------------|------------------------|
| BO/SP BR      | 103,35                 |
| BO/SP ER      | 103,35                 |
| <b>TOTAL</b>  | <b>206,7</b>           |

| <b>Tanque</b> | <b>Volumen,<br/>m3</b> |
|---------------|------------------------|
| WB 1 BR       | 68,859                 |
| WB 1 ER       | 68,859                 |
| WB 2 BR       | 79,226                 |
| WB 2 ER       | 79,226                 |

SANDRA ALLEGUE GARCÍA  
CUADERNO 4

|                           |         |
|---------------------------|---------|
| WB 3 BR                   | 71,34   |
| WB 3 ER                   | 71,34   |
| WB 4 BR                   | 77,719  |
| WB 4 ER                   | 77,719  |
| WB 5 BR                   | 56,331  |
| WB 5 ER                   | 56,331  |
| WB 6 BR-ER                |         |
| (Total)                   | 121,549 |
| <i>WB 6 BR-ER (Part)</i>  | 39,561  |
| <i>WB 6 BR-ER (Part)</i>  | 81,988  |
| WB 7 BR (Total)           | 87,39   |
| <i>WB 7 BR (Part)</i>     | 5,78    |
| <i>WB 7 BR (Part)</i>     | 38,747  |
| <i>WB 7 BR (Part)</i>     | 5,176   |
| <i>WB 7 BR (Part)</i>     | 37,687  |
| WB 7 ER (Total)           | 104,022 |
| <i>WB 7 ER (Part)</i>     | 42,747  |
| <i>WB 7 ER (Part)</i>     | 23,588  |
| <i>WB 7 ER (Part)</i>     | 37,687  |
| WB 8 BR (Total)           | 49,944  |
| <i>WB 8 BR (Part)</i>     | 15,081  |
| <i>WB 8 BR (Part)</i>     | 34,864  |
| WB 8 ER (Total)           | 49,944  |
| <i>WB 8 ER (Part)</i>     | 15,081  |
| <i>WB 8 ER (Part)</i>     | 34,864  |
| WB 9 BR                   | 43,861  |
| WB 9 ER                   | 43,861  |
| WB 10 BR                  | 46,492  |
| WB 10 ER                  | 46,492  |
| WB 11 BR-ER               |         |
| (Total)                   | 239,112 |
| <i>WB 11 BR-ER (Part)</i> | 34,47   |
| <i>WB 11 BR-ER (Part)</i> | 34,47   |
| <i>WB 11 BR-ER (Part)</i> | 45,539  |
| <i>WB 11 BR-ER (Part)</i> | 45,539  |
| <i>WB 11 BR-ER (Part)</i> | 79,094  |
| WB 12 BR-ER               | 293,228 |
| WB 13 BR-ER               |         |
| (Total)                   | 83,536  |
| <i>WB 13 BR-ER (Part)</i> | 33,205  |
| <i>WB 13 BR-ER (Part)</i> | 25,166  |

SANDRA ALLEGUE GARCÍA  
CUADERNO 4

|                                     |                 |
|-------------------------------------|-----------------|
| <i>WB 13 BR-ER</i><br><i>(Part)</i> | 25,166          |
| <b>TOTAL</b>                        | <b>1916,381</b> |

| <b>Tanque</b>         | <b>Volumen,<br/>m3</b> |
|-----------------------|------------------------|
| FW 1 BR (Total)       | 53,737                 |
| <i>FW 1 BR (Part)</i> | 33,731                 |
| <i>FW 1 BR (Part)</i> | 20,006                 |
| FW 1 ER (Total)       | 41,036                 |
| <i>FW 1 ER (Part)</i> | 21,03                  |
| <i>FW 1 ER (Part)</i> | 20,006                 |
| FW 2 BR (Total)       | 33,477                 |
| <i>FW 2 BR (Part)</i> | 12,6                   |
| <i>FW 2 BR (Part)</i> | 20,877                 |
| FW 2 ER (Total)       | 33,477                 |
| <i>FW 2 ER (Part)</i> | 12,6                   |
| <i>FW 2 ER (Part)</i> | 20,877                 |
| FW 3 BR (Total)       | 33,066                 |
| <i>FW 3 BR (Part)</i> | 23,506                 |
| <i>FW 3 BR (Part)</i> | 9,56                   |
| FW 3 ER (Total)       | 33,066                 |
| <i>FW 3 ER (Part)</i> | 23,506                 |
| <i>FW 3 ER (Part)</i> | 9,56                   |
| FW 4 BR               | 34,742                 |
| FW 4 ER               | 34,742                 |
| FW 5 BR               | 85,973                 |
| FW 5 ER               | 85,973                 |
| <b>TOTAL</b>          | <b>469,289</b>         |

| <b>Tanque</b>         | <b>Volumen,<br/>m3</b> |
|-----------------------|------------------------|
| DO 1 BR               | 157,276                |
| DO 1 ER               | 157,276                |
| DO 2 BR               | 158,696                |
| DO 2 ER               | 158,696                |
| DO 3 BR               | 147,027                |
| DO 3 ER               | 147,027                |
| DO 4 BR (Total)       | 125,433                |
| <i>DO 4 BR (Part)</i> | 79,758                 |
| <i>DO 4 BR (Part)</i> | 45,675                 |
| DO 4 ER (Total)       | 125,433                |
| <i>DO 4 ER (Part)</i> | 79,758                 |
| <i>DO 4 ER (Part)</i> | 45,675                 |
| DO SER 1              | 14,7                   |
| DO SED                | 43,68                  |

SANDRA ALLEGUE GARCÍA  
CUADERNO 4

|              |                 |
|--------------|-----------------|
| DO SER 2     | 14,7            |
| <b>TOTAL</b> | <b>1249,944</b> |

| <b>Tanque</b> | <b>Volumen,<br/>m3</b> |
|---------------|------------------------|
| LUB OIL       | 9,45                   |
| USED OIL      | 6,3                    |
| LODOS         | 3,15                   |
| SEWAGE        | 16,763                 |
| WATER MIST    | 60,529                 |
| HOT WATER     | 20,021                 |
| UREA          | 213,774                |
| DO DRAIN      | 68,731                 |
| LNG           | 36,128                 |

Siendo las abreviaturas:

CEM: cemento

MUD: lodos/salmuera/ORO (residuos de hidrocarburo)

DO/BO: Diesel oíl/aceite base

MET: metanol/xileno

BO/SP: aceite base/productos especiales

WB: agua de lastre

FW; agua potable

LUB OIL: aceite lubricante

BR: babor

ER estribor

Los tanques de Diesel oíl marcados en verde son los que se usarán para el propio consumo del buque, así como los tanques de agua potable marcados en verde también.

En los Anexos 3 y 4 se adjuntan los planos de los tanques, así como las calibraciones de estos.

# **ANEXO 1: ZONA ESTANCA Y PUNTOS DE INUNDACIÓN PROGRESIVA**

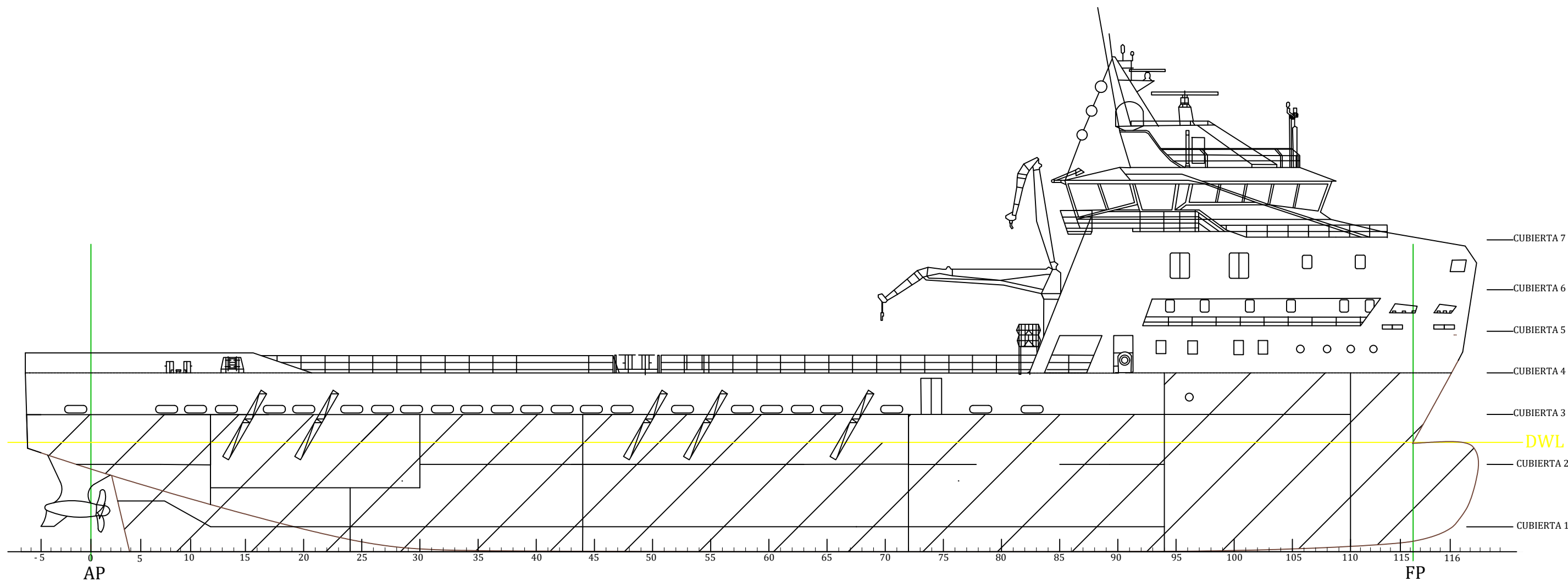

|  |                                      |
|--|--------------------------------------|
|  <b>UNIVERSIDADE DA CORUÑA</b> ESCUELA POLITÉCNICA SUPERIOR<br>GRADO EN INGENIERÍA NAVAL Y OCEÁNICA | TFG Nº: 18-02                        |
| TÍTULO DEL PLANO:<br><b>ZONA ESTANCA</b>   |                                      |
| AUTOR:<br>SANDRA ALLEGUE GARCÍA  | ESCALA: 1:250<br><b>PLANO Nº: 01</b> |

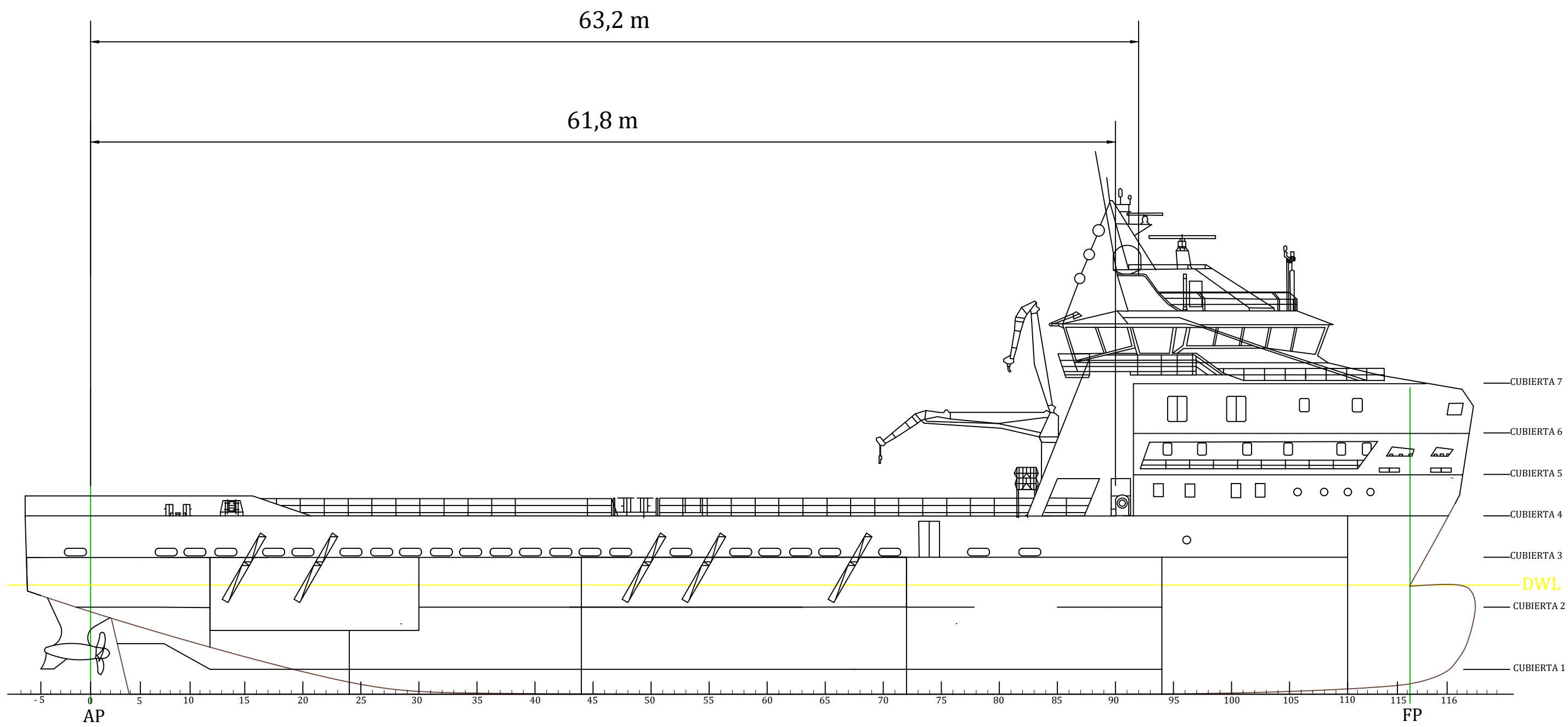



|  |               |
|--|---------------|
|  <b>UNIVERSIDADE DA CORUÑA</b> ESCUELA POLITÉCNICA SUPERIOR<br>GRADO EN INGENIERÍA NAVAL Y OCEÁNICA | TFG Nº: 18-02 |
| TÍTULO DEL PLANO:<br><b>PUNTOS DE INUNDACIÓN PROGRESIVA</b>  |               |
| AUTOR:<br>SANDRA ALLEGUE GARCÍA  | ESCALA: 1:250 |
| PLANO Nº: 02   |               |





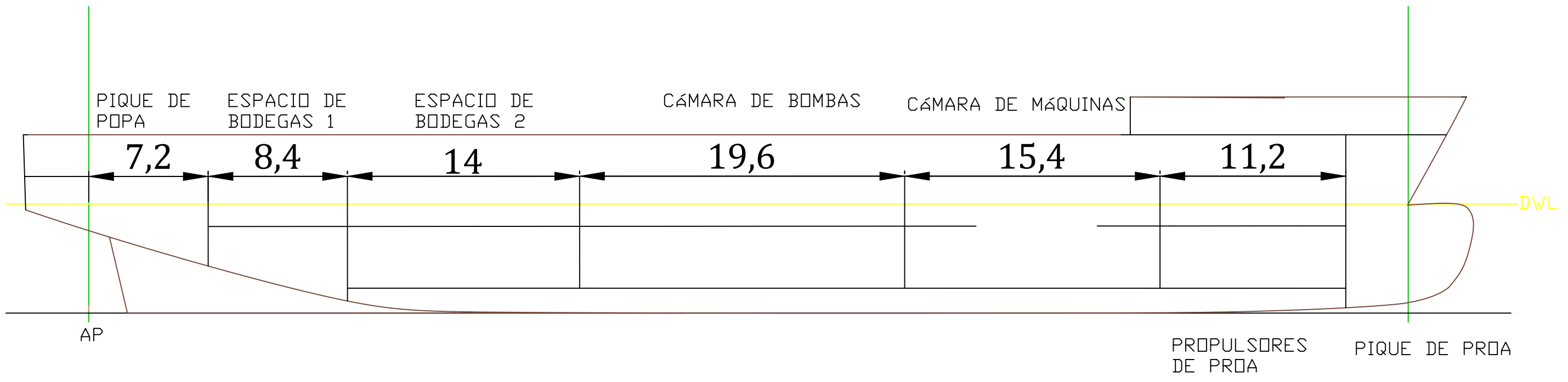

## **ANEXO 2: COMPARTIMENTADO**

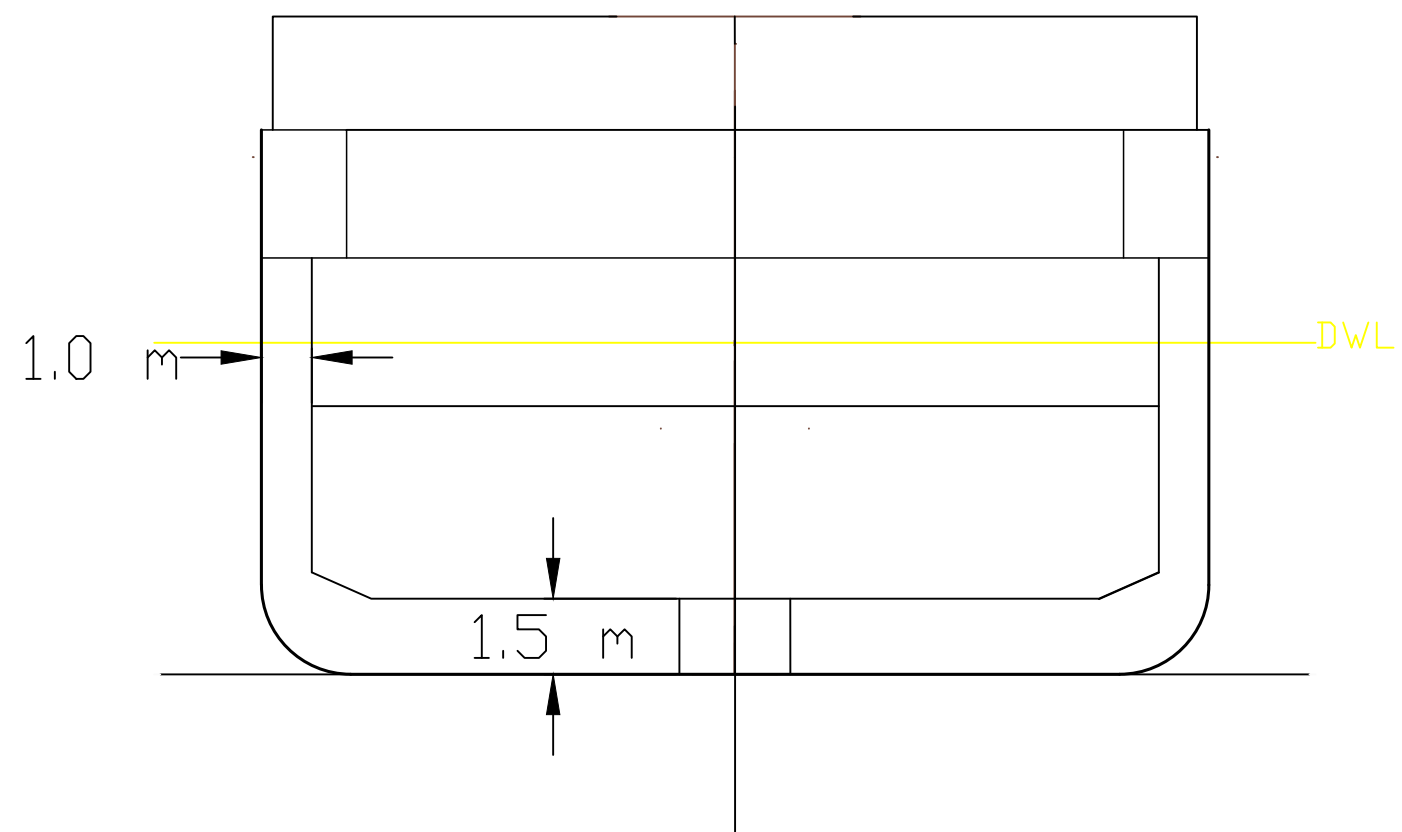

|   |               |
|---|---------------|
|  UNIVERSIDADE DA CORUÑA ESCUELA POLITÉCNICA SUPERIOR<br>GRADO EN INGENIERÍA NAVAL Y OCEÁNICA | TFG Nº: 18-02 |
| TÍTULO DEL PLANO:<br><b>COMPARTIMENTADO LONGITUDINAL</b>  |               |
| AUTOR:<br>SANDRA ALLEGUE GARCÍA   | ESCALA: 1:250 |
| PLANO Nº: 02  |               |



|   |               |
|---|---------------|
|  UNIVERSIDADE DA CORUÑA ESCUELA POLITÉCNICA SUPERIOR<br>GRADO EN INGENIERÍA NAVAL Y OCEÁNICA | TFG Nº: 18-02 |
| TÍTULO DEL PLANO:<br><b>COMPARTIMENTADO TRANSVERSAL</b>   |               |
| AUTOR:<br>SANDRA ALLEGUE GARCÍA   | ESCALA: 1:150 |
| PLANO Nº: 03  |               |

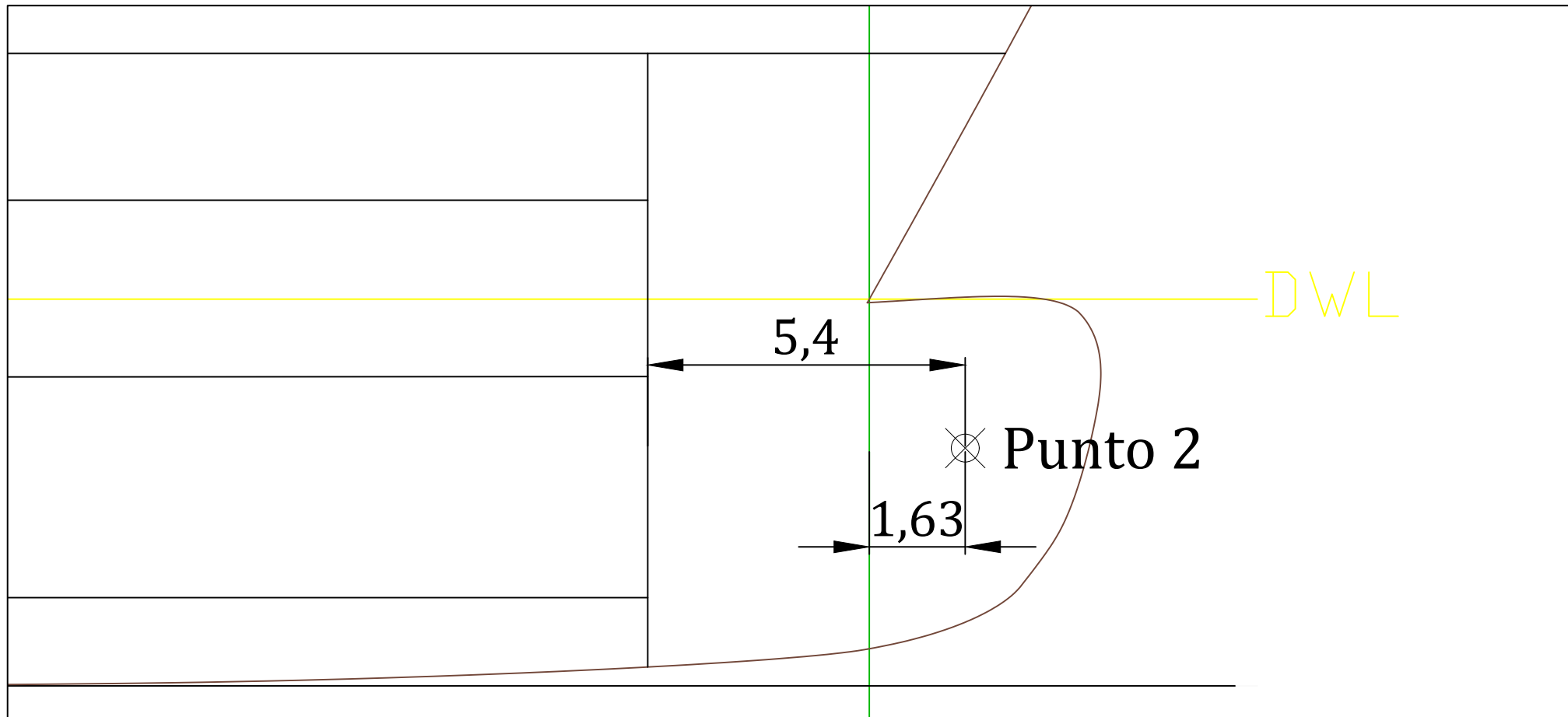

UNIVERSIDADE DA CORUÑA

ESCUELA POLITÉCNICA SUPERIOR

GRADO EN INGENIERÍA NAVAL Y OCEÁNICA

TFG Nº: 18-02

TÍTULO DEL PLANO:

AMPLIACIÓN MAMPARO DE COLISIÓN

AUTOR:

SANDRA ALLEGUE GARCÍA

ESCALA: 1:100

PLANO Nº: 04

## **ANEXO 3: PLANOS DE TANQUES**

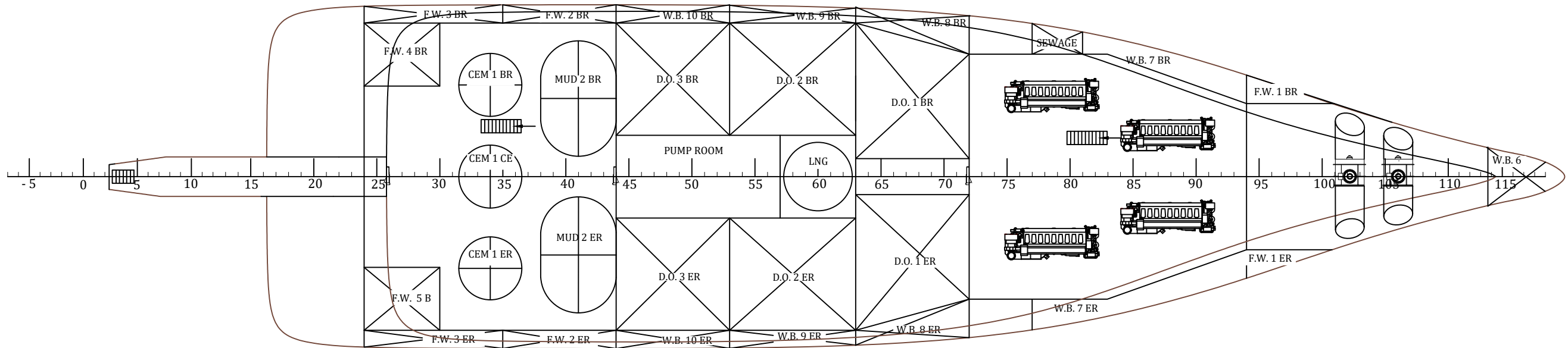
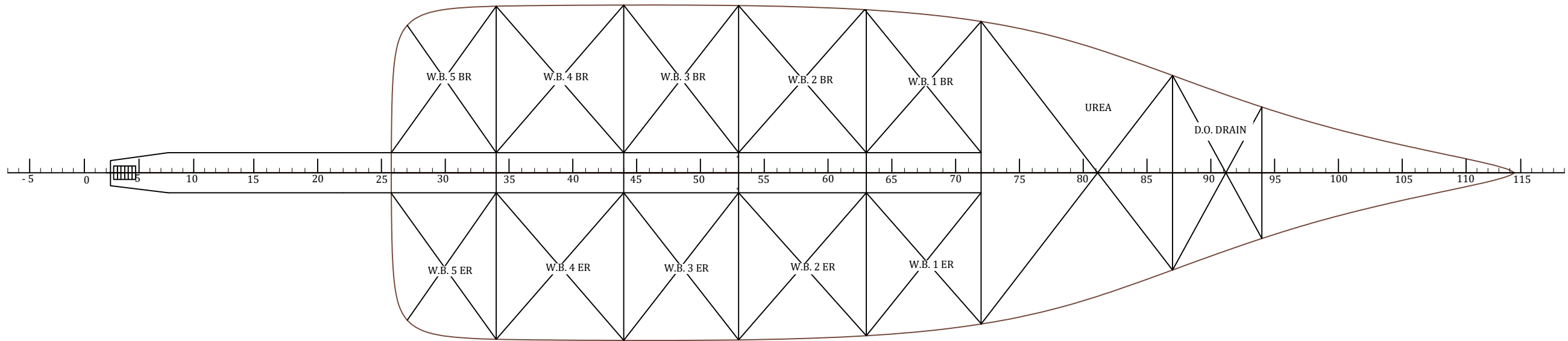

UNIVERSIDADE DA CORUÑA ESCUELA POLITÉCNICA SUPERIOR  
GRADO EN INGENIERÍA NAVAL Y OCEÁNICA

TFG Nº: 18-02

TÍTULO DEL PLANO:

DISPOSICIÓN GENERAL. DOBLE FONDO Y CUBIERTA 1

AUTOR:

SANDRA ALLEGUE GARCÍA

ESCALA: 1:250

PLANO Nº: 02

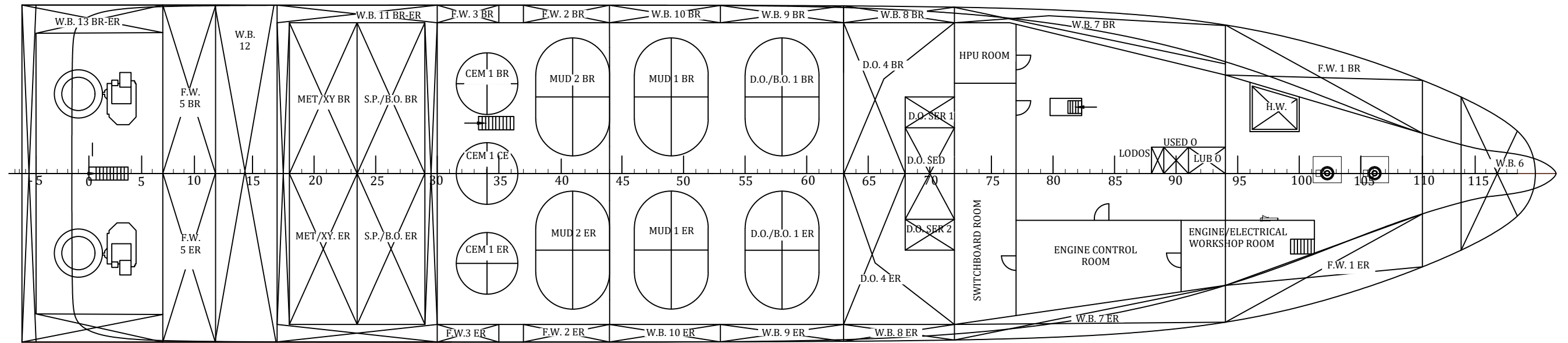

|  |               |
|--|---------------|
|  <b>UNIVERSIDADE DA CORUÑA</b> ESCUELA POLITÉCNICA SUPERIOR<br>GRADO EN INGENIERÍA NAVAL Y OCEÁNICA | TFG Nº: 18-02 |
| TÍTULO DEL PLANO:<br><b>DISPOSICIÓN GENERAL. CUBIERTA 2</b>  |               |
| AUTOR:<br>SANDRA ALLEGUE GARCÍA  | ESCALA: 1:250 |
| <b>PLANO Nº: 03</b>  |               |

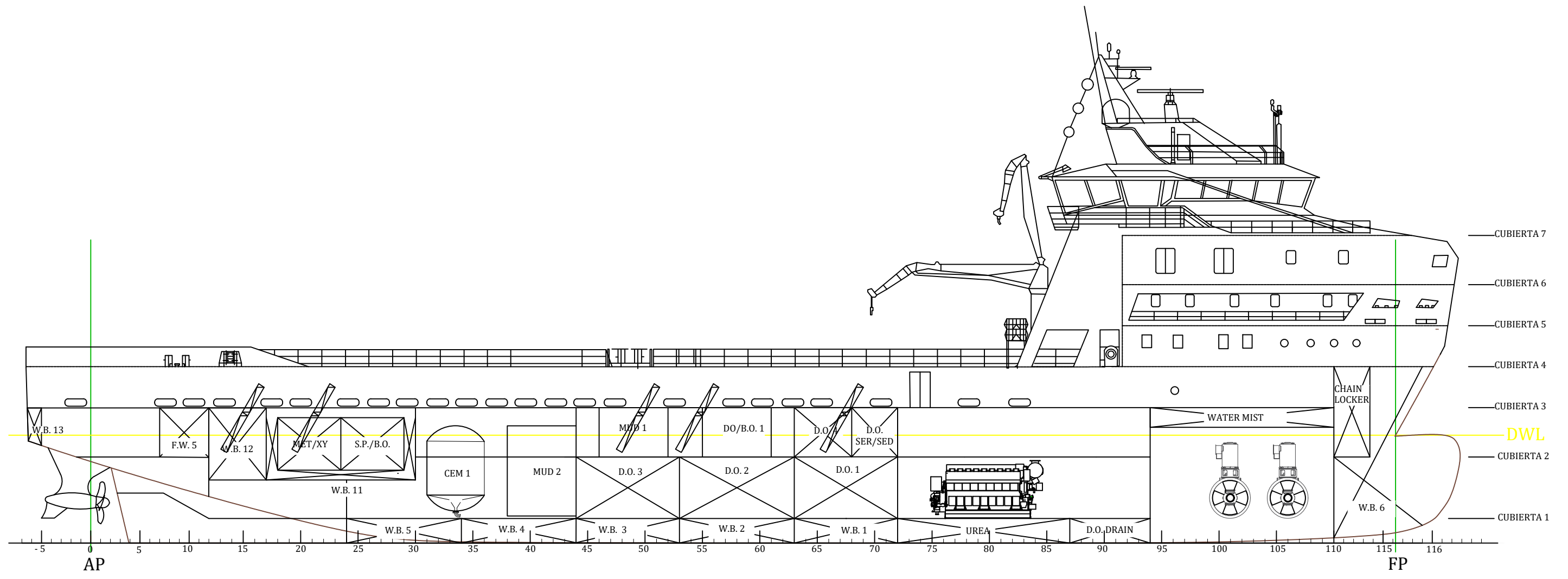

|  |               |
|--|---------------|
|  <b>UNIVERSIDADE DA CORUÑA</b> ESCUELA POLITÉCNICA SUPERIOR<br>GRADO EN INGENIERÍA NAVAL Y OCEÁNICA | TFG Nº: 18-02 |
| TÍTULO DEL PLANO:<br><b>DISPOSICIÓN GENERAL. PERFIL</b>  |               |
| AUTOR:<br>SANDRA ALLEGUE GARCÍA  | ESCALA: 1:250 |
| <b>PLANO Nº: 01</b>  |               |



# **ANEXO 4: CALIBRACIONES DE TANQUES**

# Tank Calibrations - ZAONA ESTANCA

Stability 21.11.00.84, build: 84

## Tank Calibrations - CEM 1 BR

Fluid Type = Cement/Mud Specific gravity = 2,8

Permeability = 100 %

Trim = 0 m (+ve by stern); Heel = 0 deg to starboard

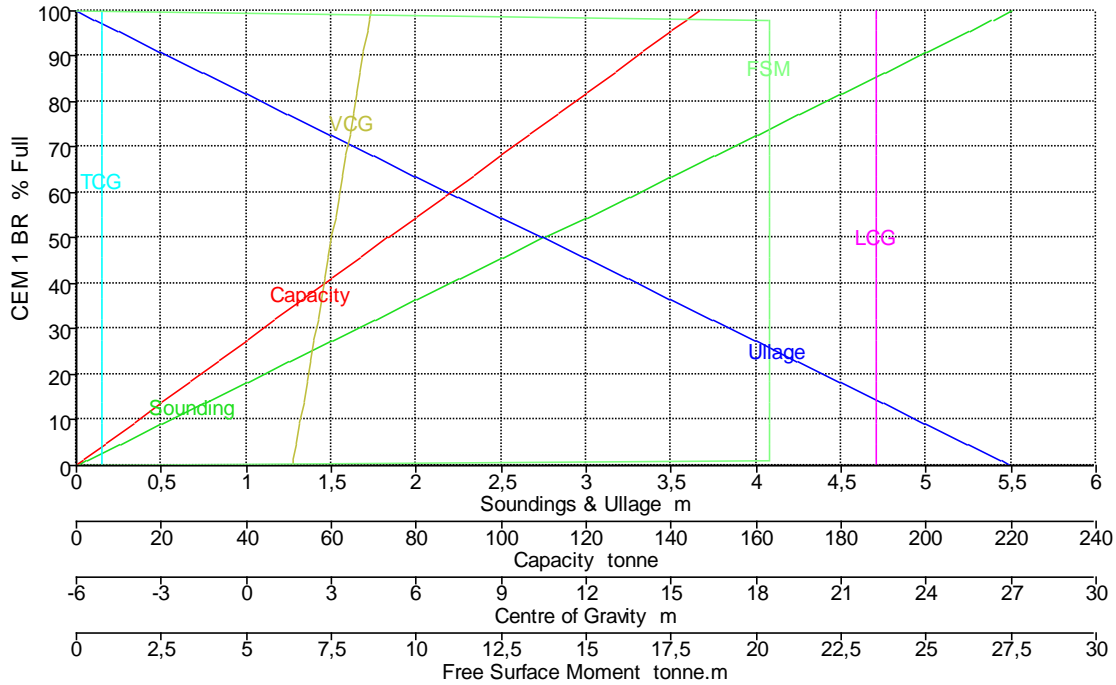

| Tank Name | Sounding m | Ullage m | % Full  | Capacity m <sup>3</sup> | Capacity tonne | LCG m  | TCG m  | VCG m | FSM tonne.m |
|-----------|------------|----------|---------|-------------------------|----------------|--------|--------|-------|-------------|
| CEM 1 BR  | 5,500      | 0,000    | 100,000 | 52,339                  | 146,548        | 22,250 | -5,100 | 4,400 | 0,000       |
|           | 5,390      | 0,110    | 98,000  | 51,292                  | 143,617        | 22,250 | -5,100 | 4,345 | 20,390      |
|           | 5,385      | 0,115    | 97,900  | 51,240                  | 143,471        | 22,250 | -5,100 | 4,342 | 20,390      |
|           | 5,250      | 0,250    | 95,455  | 49,960                  | 139,887        | 22,250 | -5,100 | 4,275 | 20,390      |
|           | 5,000      | 0,500    | 90,909  | 47,581                  | 133,226        | 22,250 | -5,100 | 4,150 | 20,390      |
|           | 4,750      | 0,750    | 86,364  | 45,202                  | 126,565        | 22,250 | -5,100 | 4,025 | 20,390      |
|           | 4,500      | 1,000    | 81,818  | 42,823                  | 119,903        | 22,250 | -5,100 | 3,900 | 20,390      |
|           | 4,250      | 1,250    | 77,273  | 40,444                  | 113,242        | 22,250 | -5,100 | 3,775 | 20,390      |
|           | 4,000      | 1,500    | 72,727  | 38,065                  | 106,581        | 22,250 | -5,100 | 3,650 | 20,390      |
|           | 3,750      | 1,750    | 68,182  | 35,685                  | 99,919         | 22,250 | -5,100 | 3,525 | 20,390      |
|           | 3,500      | 2,000    | 63,636  | 33,306                  | 93,258         | 22,250 | -5,100 | 3,400 | 20,390      |
|           | 3,250      | 2,250    | 59,091  | 30,927                  | 86,597         | 22,250 | -5,100 | 3,275 | 20,390      |
|           | 3,000      | 2,500    | 54,545  | 28,548                  | 79,935         | 22,250 | -5,100 | 3,150 | 20,390      |
|           | 2,750      | 2,750    | 50,000  | 26,169                  | 73,274         | 22,250 | -5,100 | 3,025 | 20,390      |
|           | 2,500      | 3,000    | 45,455  | 23,790                  | 66,613         | 22,250 | -5,100 | 2,900 | 20,390      |
|           | 2,250      | 3,250    | 40,909  | 21,411                  | 59,952         | 22,250 | -5,100 | 2,775 | 20,390      |
|           | 2,000      | 3,500    | 36,364  | 19,032                  | 53,290         | 22,250 | -5,100 | 2,650 | 20,390      |
|           | 1,750      | 3,750    | 31,818  | 16,653                  | 46,629         | 22,250 | -5,100 | 2,525 | 20,390      |
|           | 1,500      | 4,000    | 27,273  | 14,274                  | 39,968         | 22,250 | -5,100 | 2,400 | 20,390      |
|           | 1,250      | 4,250    | 22,727  | 11,895                  | 33,306         | 22,250 | -5,100 | 2,275 | 20,390      |
|           | 1,000      | 4,500    | 18,182  | 9,516                   | 26,645         | 22,250 | -5,100 | 2,150 | 20,390      |
|           | 0,750      | 4,750    | 13,636  | 7,137                   | 19,984         | 22,250 | -5,100 | 2,025 | 20,390      |
|           | 0,500      | 5,000    | 9,091   | 4,758                   | 13,323         | 22,250 | -5,100 | 1,900 | 20,390      |
|           | 0,250      | 5,250    | 4,545   | 2,379                   | 6,661          | 22,250 | -5,100 | 1,775 | 20,390      |
|           | 0,055      | 5,445    | 1,000   | 0,523                   | 1,465          | 22,250 | -5,100 | 1,678 | 20,390      |

| Tank Name | Sounding m | Ullage m | % Full | Capacity m <sup>3</sup> | Capacity tonne | LCG m  | TCG m  | VCG m | FSM tonne.m |
|-----------|------------|----------|--------|-------------------------|----------------|--------|--------|-------|-------------|
|           | 0,000      | 5,500    | 0,000  | 0,000                   | 0,000          | 22,250 | -5,100 | 1,650 | 0,000       |

### Tank Calibrations - CEM 1 CE

Fluid Type = Cement/Mud      Specific gravity = 2,8  
 Permeability = 100 %  
 Trim = 0 m (+ve by stern); Heel = 0 deg to starboard

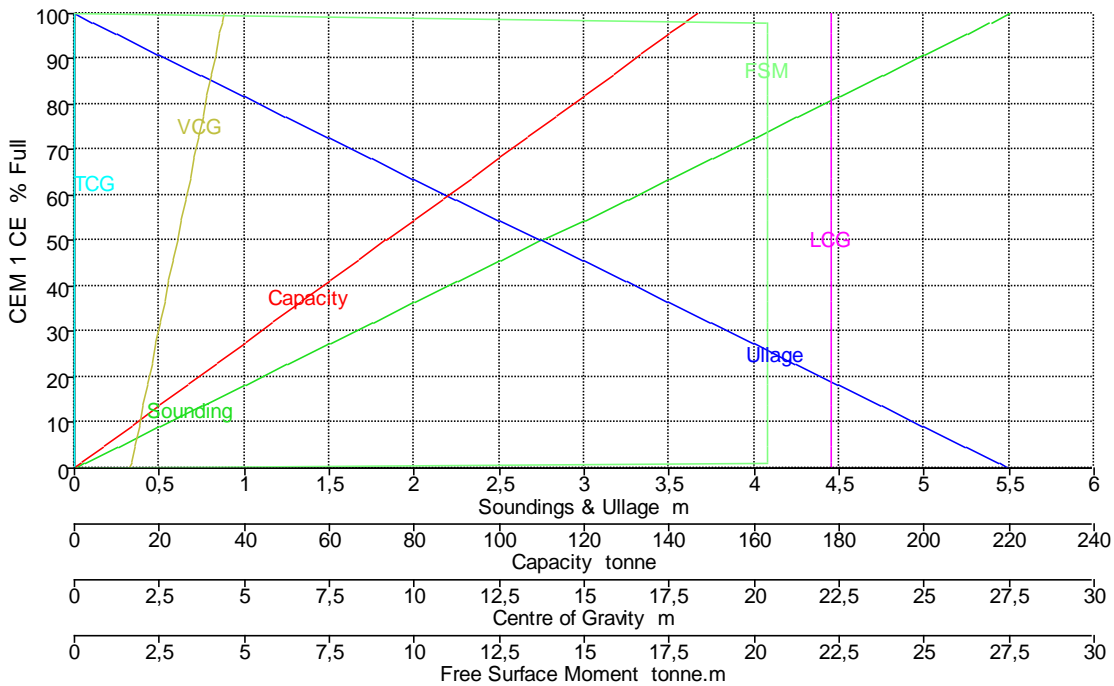

| Tank Name | Sounding m | Ullage m | % Full  | Capacity m <sup>3</sup> | Capacity tonne | LCG m  | TCG m | VCG m | FSM tonne.m |
|-----------|------------|----------|---------|-------------------------|----------------|--------|-------|-------|-------------|
| CEM 1 CE  | 5,500      | 0,000    | 100,000 | 52,339                  | 146,548        | 22,250 | 0,000 | 4,400 | 0,000       |
|           | 5,390      | 0,110    | 98,000  | 51,292                  | 143,617        | 22,250 | 0,000 | 4,345 | 20,390      |
|           | 5,385      | 0,115    | 97,900  | 51,240                  | 143,471        | 22,250 | 0,000 | 4,342 | 20,390      |
|           | 5,250      | 0,250    | 95,455  | 49,960                  | 139,887        | 22,250 | 0,000 | 4,275 | 20,390      |
|           | 5,000      | 0,500    | 90,909  | 47,581                  | 133,226        | 22,250 | 0,000 | 4,150 | 20,390      |
|           | 4,750      | 0,750    | 86,364  | 45,202                  | 126,564        | 22,250 | 0,000 | 4,025 | 20,390      |
|           | 4,500      | 1,000    | 81,818  | 42,823                  | 119,903        | 22,250 | 0,000 | 3,900 | 20,390      |
|           | 4,250      | 1,250    | 77,273  | 40,444                  | 113,242        | 22,250 | 0,000 | 3,775 | 20,390      |
|           | 4,000      | 1,500    | 72,727  | 38,065                  | 106,581        | 22,250 | 0,000 | 3,650 | 20,390      |
|           | 3,750      | 1,750    | 68,182  | 35,685                  | 99,919         | 22,250 | 0,000 | 3,525 | 20,390      |
|           | 3,500      | 2,000    | 63,636  | 33,306                  | 93,258         | 22,250 | 0,000 | 3,400 | 20,390      |
|           | 3,250      | 2,250    | 59,091  | 30,927                  | 86,597         | 22,250 | 0,000 | 3,275 | 20,390      |
|           | 3,000      | 2,500    | 54,545  | 28,548                  | 79,935         | 22,250 | 0,000 | 3,150 | 20,390      |
|           | 2,750      | 2,750    | 50,000  | 26,169                  | 73,274         | 22,250 | 0,000 | 3,025 | 20,390      |
|           | 2,500      | 3,000    | 45,455  | 23,790                  | 66,613         | 22,250 | 0,000 | 2,900 | 20,390      |
|           | 2,250      | 3,250    | 40,909  | 21,411                  | 59,952         | 22,250 | 0,000 | 2,775 | 20,390      |
|           | 2,000      | 3,500    | 36,364  | 19,032                  | 53,290         | 22,250 | 0,000 | 2,650 | 20,390      |
|           | 1,750      | 3,750    | 31,818  | 16,653                  | 46,629         | 22,250 | 0,000 | 2,525 | 20,390      |
|           | 1,500      | 4,000    | 27,273  | 14,274                  | 39,968         | 22,250 | 0,000 | 2,400 | 20,390      |
|           | 1,250      | 4,250    | 22,727  | 11,895                  | 33,306         | 22,250 | 0,000 | 2,275 | 20,390      |
|           | 1,000      | 4,500    | 18,182  | 9,516                   | 26,645         | 22,250 | 0,000 | 2,150 | 20,390      |
|           | 0,750      | 4,750    | 13,636  | 7,137                   | 19,984         | 22,250 | 0,000 | 2,025 | 20,390      |

| Tank Name | Sounding m | Ullage m | % Full | Capacity m <sup>3</sup> | Capacity tonne | LCG m  | TCG m | VCG m | FSM tonne.m |
|-----------|------------|----------|--------|-------------------------|----------------|--------|-------|-------|-------------|
|           | 0,500      | 5,000    | 9,091  | 4,758                   | 13,323         | 22,250 | 0,000 | 1,900 | 20,390      |
|           | 0,250      | 5,250    | 4,545  | 2,379                   | 6,661          | 22,250 | 0,000 | 1,775 | 20,390      |
|           | 0,055      | 5,445    | 1,000  | 0,523                   | 1,465          | 22,250 | 0,000 | 1,678 | 20,390      |
|           | 0,000      | 5,500    | 0,000  | 0,000                   | 0,000          | 22,250 | 0,000 | 1,650 | 0,000       |

### Tank Calibrations - CEM 1 ER

Fluid Type = Cement/Mud      Specific gravity = 2,8

Permeability = 100 %

Trim = 0 m (+ve by stern); Heel = 0 deg to starboard

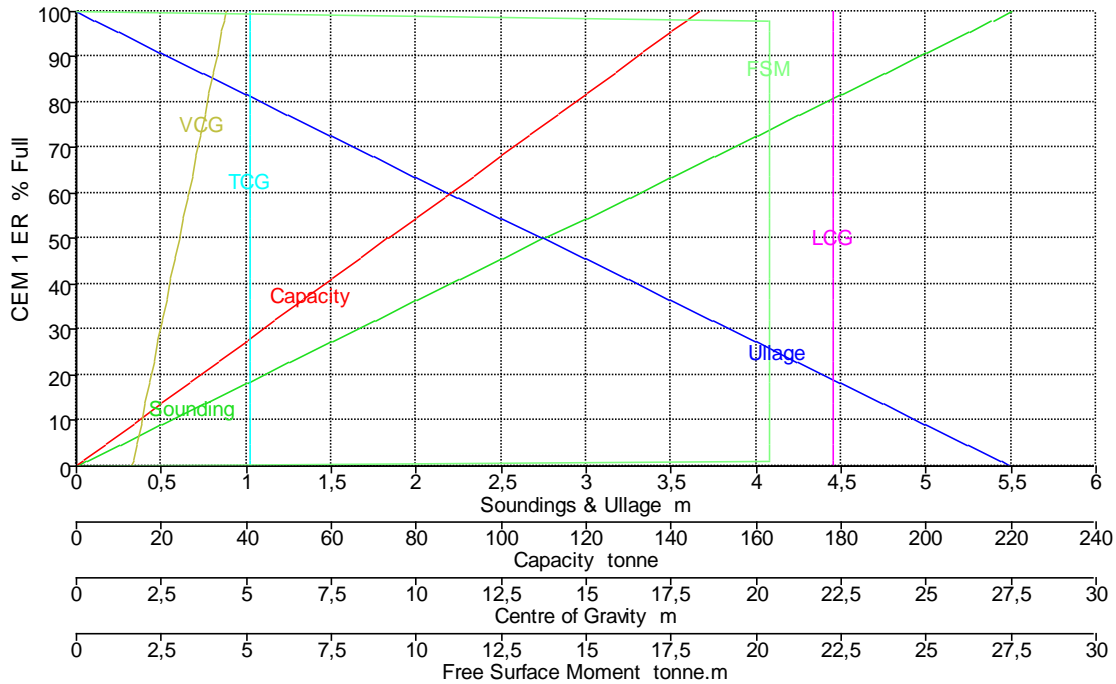

| Tank Name | Sounding m | Ullage m | % Full  | Capacity m <sup>3</sup> | Capacity tonne | LCG m  | TCG m | VCG m | FSM tonne.m |
|-----------|------------|----------|---------|-------------------------|----------------|--------|-------|-------|-------------|
| CEM 1 ER  | 5,500      | 0,000    | 100,000 | 52,339                  | 146,548        | 22,250 | 5,100 | 4,400 | 0,000       |
|           | 5,390      | 0,110    | 98,000  | 51,292                  | 143,617        | 22,250 | 5,100 | 4,345 | 20,390      |
|           | 5,385      | 0,115    | 97,900  | 51,240                  | 143,471        | 22,250 | 5,100 | 4,342 | 20,390      |
|           | 5,250      | 0,250    | 95,455  | 49,960                  | 139,887        | 22,250 | 5,100 | 4,275 | 20,390      |
|           | 5,000      | 0,500    | 90,909  | 47,581                  | 133,226        | 22,250 | 5,100 | 4,150 | 20,390      |
|           | 4,750      | 0,750    | 86,364  | 45,202                  | 126,565        | 22,250 | 5,100 | 4,025 | 20,390      |
|           | 4,500      | 1,000    | 81,818  | 42,823                  | 119,903        | 22,250 | 5,100 | 3,900 | 20,390      |
|           | 4,250      | 1,250    | 77,273  | 40,444                  | 113,242        | 22,250 | 5,100 | 3,775 | 20,390      |
|           | 4,000      | 1,500    | 72,727  | 38,065                  | 106,581        | 22,250 | 5,100 | 3,650 | 20,390      |
|           | 3,750      | 1,750    | 68,182  | 35,685                  | 99,919         | 22,250 | 5,100 | 3,525 | 20,390      |
|           | 3,500      | 2,000    | 63,636  | 33,306                  | 93,258         | 22,250 | 5,100 | 3,400 | 20,390      |
|           | 3,250      | 2,250    | 59,091  | 30,927                  | 86,597         | 22,250 | 5,100 | 3,275 | 20,390      |
|           | 3,000      | 2,500    | 54,545  | 28,548                  | 79,935         | 22,250 | 5,100 | 3,150 | 20,390      |
|           | 2,750      | 2,750    | 50,000  | 26,169                  | 73,274         | 22,250 | 5,100 | 3,025 | 20,390      |
|           | 2,500      | 3,000    | 45,455  | 23,790                  | 66,613         | 22,250 | 5,100 | 2,900 | 20,390      |
|           | 2,250      | 3,250    | 40,909  | 21,411                  | 59,952         | 22,250 | 5,100 | 2,775 | 20,390      |
|           | 2,000      | 3,500    | 36,364  | 19,032                  | 53,290         | 22,250 | 5,100 | 2,650 | 20,390      |
|           | 1,750      | 3,750    | 31,818  | 16,653                  | 46,629         | 22,250 | 5,100 | 2,525 | 20,390      |
|           | 1,500      | 4,000    | 27,273  | 14,274                  | 39,968         | 22,250 | 5,100 | 2,400 | 20,390      |

| Tank Name | Sounding m | Ullage m | % Full | Capacity m <sup>3</sup> | Capacity tonne | LCG m  | TCG m | VCG m | FSM tonne.m |
|-----------|------------|----------|--------|-------------------------|----------------|--------|-------|-------|-------------|
|           | 1,250      | 4,250    | 22,727 | 11,895                  | 33,306         | 22,250 | 5,100 | 2,275 | 20,390      |
|           | 1,000      | 4,500    | 18,182 | 9,516                   | 26,645         | 22,250 | 5,100 | 2,150 | 20,390      |
|           | 0,750      | 4,750    | 13,636 | 7,137                   | 19,984         | 22,250 | 5,100 | 2,025 | 20,390      |
|           | 0,500      | 5,000    | 9,091  | 4,758                   | 13,323         | 22,250 | 5,100 | 1,900 | 20,390      |
|           | 0,250      | 5,250    | 4,545  | 2,379                   | 6,661          | 22,250 | 5,100 | 1,775 | 20,390      |
|           | 0,055      | 5,445    | 1,000  | 0,523                   | 1,465          | 22,250 | 5,100 | 1,678 | 20,390      |
|           | 0,000      | 5,500    | 0,000  | 0,000                   | 0,000          | 22,250 | 5,100 | 1,650 | 0,000       |

### Tank Calibrations - MUD 1 BR

Fluid Type = Cement/Mud      Specific gravity = 2,8

Permeability = 98 %

Trim = 0 m (+ve by stern); Heel = 0 deg to starboard

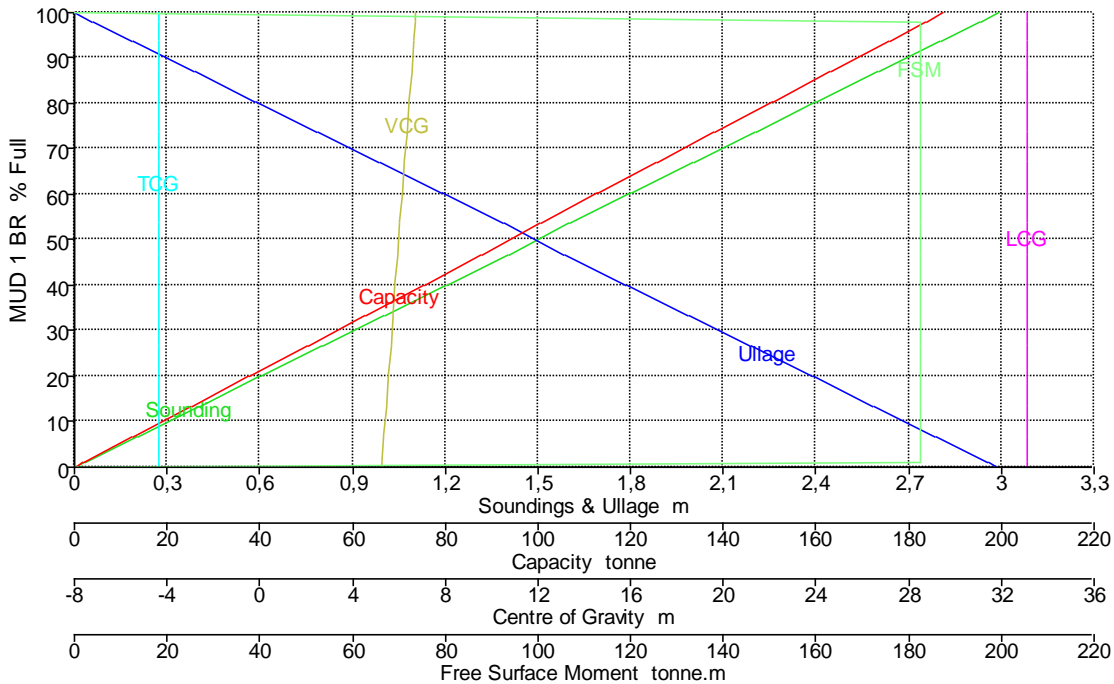

| Tank Name | Sounding m | Ullage m | % Full  | Capacity m <sup>3</sup> | Capacity tonne | LCG m  | TCG m  | VCG m | FSM tonne.m |
|-----------|------------|----------|---------|-------------------------|----------------|--------|--------|-------|-------------|
| MUD 1 BR  | 2,990      | 0,000    | 100,000 | 66,933                  | 187,414        | 33,100 | -4,350 | 6,745 | 0,000       |
|           | 2,930      | 0,060    | 98,000  | 65,595                  | 183,665        | 33,100 | -4,350 | 6,715 | 182,424     |
|           | 2,927      | 0,063    | 97,900  | 65,528                  | 183,478        | 33,100 | -4,350 | 6,714 | 182,424     |
|           | 2,800      | 0,190    | 93,645  | 62,680                  | 175,504        | 33,100 | -4,350 | 6,650 | 182,424     |
|           | 2,600      | 0,390    | 86,957  | 58,203                  | 162,968        | 33,100 | -4,350 | 6,550 | 182,424     |
|           | 2,400      | 0,590    | 80,268  | 53,726                  | 150,432        | 33,100 | -4,350 | 6,450 | 182,424     |
|           | 2,200      | 0,790    | 73,579  | 49,249                  | 137,896        | 33,100 | -4,350 | 6,350 | 182,424     |
|           | 2,000      | 0,990    | 66,890  | 44,772                  | 125,360        | 33,100 | -4,350 | 6,250 | 182,424     |
|           | 1,800      | 1,190    | 60,201  | 40,294                  | 112,824        | 33,100 | -4,350 | 6,150 | 182,424     |
|           | 1,600      | 1,390    | 53,512  | 35,817                  | 100,288        | 33,100 | -4,350 | 6,050 | 182,424     |
|           | 1,400      | 1,590    | 46,823  | 31,340                  | 87,752         | 33,100 | -4,350 | 5,950 | 182,424     |
|           | 1,200      | 1,790    | 40,134  | 26,863                  | 75,216         | 33,100 | -4,350 | 5,850 | 182,424     |
|           | 1,000      | 1,990    | 33,445  | 22,386                  | 62,680         | 33,100 | -4,350 | 5,750 | 182,424     |
|           | 0,800      | 2,190    | 26,756  | 17,909                  | 50,144         | 33,100 | -4,350 | 5,650 | 182,424     |
|           | 0,600      | 2,390    | 20,067  | 13,431                  | 37,608         | 33,100 | -4,350 | 5,550 | 182,424     |
|           | 0,400      | 2,590    | 13,378  | 8,954                   | 25,072         | 33,100 | -4,350 | 5,450 | 182,424     |

| Tank Name | Sounding m | Ullage m | % Full | Capacity m <sup>3</sup> | Capacity tonne | LCG m  | TCG m  | VCG m | FSM tonne.m |
|-----------|------------|----------|--------|-------------------------|----------------|--------|--------|-------|-------------|
|           | 0,200      | 2,790    | 6,689  | 4,477                   | 12,536         | 33,100 | -4,350 | 5,350 | 182,424     |
|           | 0,030      | 2,960    | 1,000  | 0,669                   | 1,874          | 33,100 | -4,350 | 5,265 | 182,424     |
|           | 0,000      | 2,990    | 0,000  | 0,000                   | 0,000          | 33,100 | -4,350 | 5,250 | 0,000       |

### Tank Calibrations - MUD 1 ER

Fluid Type = Cement/Mud      Specific gravity = 2,8  
 Permeability = 98 %  
 Trim = 0 m (+ve by stern); Heel = 0 deg to starboard

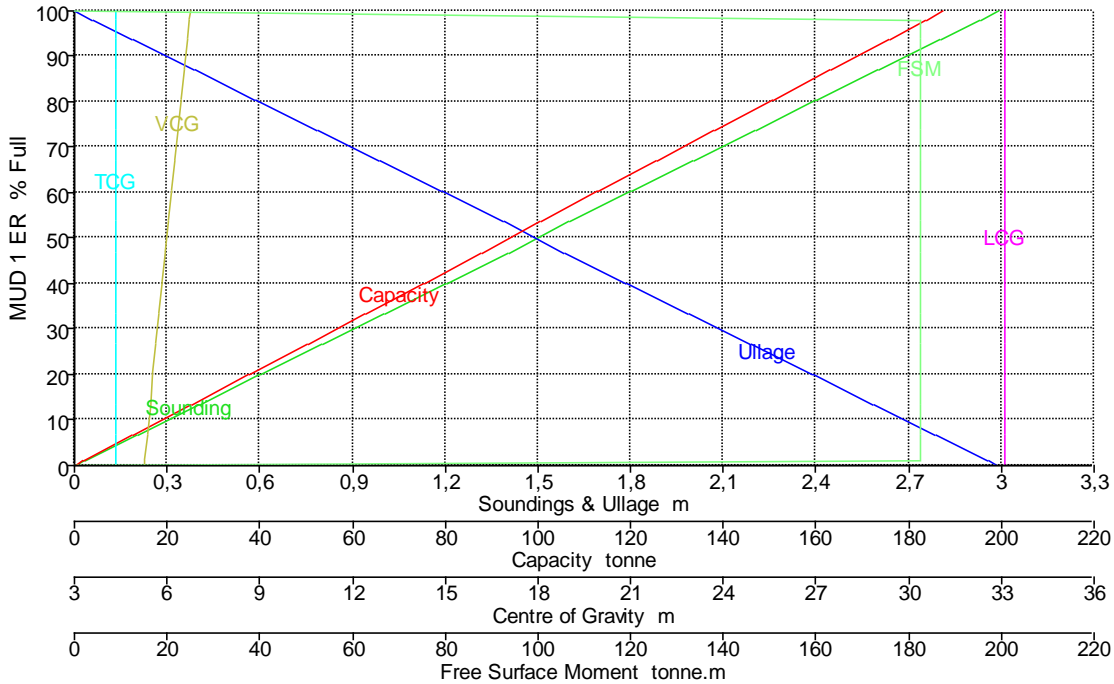

| Tank Name | Sounding m | Ullage m | % Full  | Capacity m <sup>3</sup> | Capacity tonne | LCG m  | TCG m | VCG m | FSM tonne.m |
|-----------|------------|----------|---------|-------------------------|----------------|--------|-------|-------|-------------|
| MUD 1 ER  | 2,990      | 0,000    | 100,000 | 66,933                  | 187,414        | 33,100 | 4,350 | 6,745 | 0,000       |
|           | 2,930      | 0,060    | 98,000  | 65,595                  | 183,665        | 33,100 | 4,350 | 6,715 | 182,424     |
|           | 2,927      | 0,063    | 97,900  | 65,528                  | 183,478        | 33,100 | 4,350 | 6,714 | 182,424     |
|           | 2,800      | 0,190    | 93,645  | 62,680                  | 175,504        | 33,100 | 4,350 | 6,650 | 182,424     |
|           | 2,600      | 0,390    | 86,957  | 58,203                  | 162,968        | 33,100 | 4,350 | 6,550 | 182,424     |
|           | 2,400      | 0,590    | 80,268  | 53,726                  | 150,432        | 33,100 | 4,350 | 6,450 | 182,424     |
|           | 2,200      | 0,790    | 73,579  | 49,249                  | 137,896        | 33,100 | 4,350 | 6,350 | 182,424     |
|           | 2,000      | 0,990    | 66,890  | 44,772                  | 125,360        | 33,100 | 4,350 | 6,250 | 182,424     |
|           | 1,800      | 1,190    | 60,201  | 40,294                  | 112,824        | 33,100 | 4,350 | 6,150 | 182,424     |
|           | 1,600      | 1,390    | 53,512  | 35,817                  | 100,288        | 33,100 | 4,350 | 6,050 | 182,424     |
|           | 1,400      | 1,590    | 46,823  | 31,340                  | 87,752         | 33,100 | 4,350 | 5,950 | 182,424     |
|           | 1,200      | 1,790    | 40,134  | 26,863                  | 75,216         | 33,100 | 4,350 | 5,850 | 182,424     |
|           | 1,000      | 1,990    | 33,445  | 22,386                  | 62,680         | 33,100 | 4,350 | 5,750 | 182,424     |
|           | 0,800      | 2,190    | 26,756  | 17,909                  | 50,144         | 33,100 | 4,350 | 5,650 | 182,424     |
|           | 0,600      | 2,390    | 20,067  | 13,431                  | 37,608         | 33,100 | 4,350 | 5,550 | 182,424     |
|           | 0,400      | 2,590    | 13,378  | 8,954                   | 25,072         | 33,100 | 4,350 | 5,450 | 182,424     |
|           | 0,200      | 2,790    | 6,689   | 4,477                   | 12,536         | 33,100 | 4,350 | 5,350 | 182,424     |
|           | 0,030      | 2,960    | 1,000   | 0,669                   | 1,874          | 33,100 | 4,350 | 5,265 | 182,424     |
|           | 0,000      | 2,990    | 0,000   | 0,000                   | 0,000          | 33,100 | 4,350 | 5,250 | 0,000       |

### Tank Calibrations - MUD 2 BR

Fluid Type = Cement/Mud      Specific gravity = 2,8

Permeability = 98 %

Trim = 0 m (+ve by stern); Heel = 0 deg to starboard

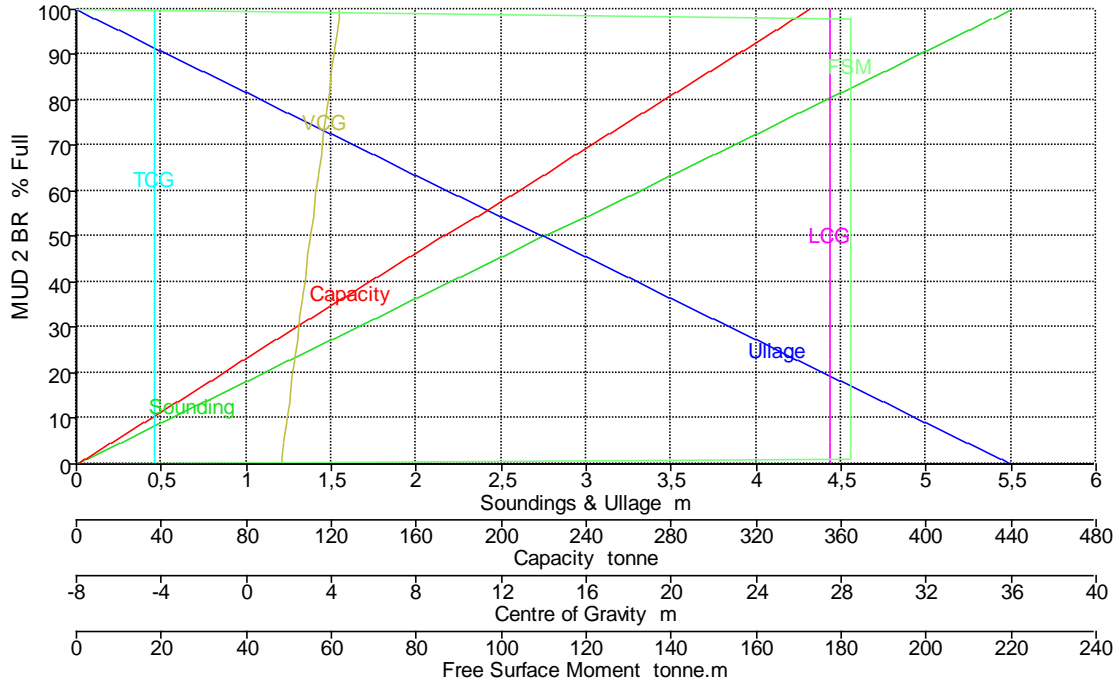

| Tank Name | Sounding m | Ullage m | % Full  | Capacity m <sup>3</sup> | Capacity tonne | LCG m  | TCG m  | VCG m | FSM tonne.m |
|-----------|------------|----------|---------|-------------------------|----------------|--------|--------|-------|-------------|
| MUD 2 BR  | 5,500      | 0,000    | 100,000 | 123,122                 | 344,741        | 27,500 | -4,350 | 4,400 | 0,000       |
|           | 5,390      | 0,110    | 98,000  | 120,659                 | 337,846        | 27,500 | -4,350 | 4,345 | 182,424     |
|           | 5,385      | 0,115    | 97,900  | 120,536                 | 337,501        | 27,500 | -4,350 | 4,342 | 182,424     |
|           | 5,250      | 0,250    | 95,455  | 117,525                 | 329,071        | 27,500 | -4,350 | 4,275 | 182,424     |
|           | 5,000      | 0,500    | 90,909  | 111,929                 | 313,401        | 27,500 | -4,350 | 4,150 | 182,424     |
|           | 4,750      | 0,750    | 86,364  | 106,332                 | 297,731        | 27,500 | -4,350 | 4,025 | 182,424     |
|           | 4,500      | 1,000    | 81,818  | 100,736                 | 282,061        | 27,500 | -4,350 | 3,900 | 182,424     |
|           | 4,250      | 1,250    | 77,273  | 95,140                  | 266,391        | 27,500 | -4,350 | 3,775 | 182,424     |
|           | 4,000      | 1,500    | 72,727  | 89,543                  | 250,721        | 27,500 | -4,350 | 3,650 | 182,424     |
|           | 3,750      | 1,750    | 68,182  | 83,947                  | 235,051        | 27,500 | -4,350 | 3,525 | 182,424     |
|           | 3,500      | 2,000    | 63,636  | 78,350                  | 219,381        | 27,500 | -4,350 | 3,400 | 182,424     |
|           | 3,250      | 2,250    | 59,091  | 72,754                  | 203,711        | 27,500 | -4,350 | 3,275 | 182,424     |
|           | 3,000      | 2,500    | 54,545  | 67,157                  | 188,041        | 27,500 | -4,350 | 3,150 | 182,424     |
|           | 2,750      | 2,750    | 50,000  | 61,561                  | 172,370        | 27,500 | -4,350 | 3,025 | 182,424     |
|           | 2,500      | 3,000    | 45,455  | 55,964                  | 156,700        | 27,500 | -4,350 | 2,900 | 182,424     |
|           | 2,250      | 3,250    | 40,909  | 50,368                  | 141,030        | 27,500 | -4,350 | 2,775 | 182,424     |
|           | 2,000      | 3,500    | 36,364  | 44,772                  | 125,360        | 27,500 | -4,350 | 2,650 | 182,424     |
|           | 1,750      | 3,750    | 31,818  | 39,175                  | 109,690        | 27,500 | -4,350 | 2,525 | 182,424     |
|           | 1,500      | 4,000    | 27,273  | 33,579                  | 94,020         | 27,500 | -4,350 | 2,400 | 182,424     |
|           | 1,250      | 4,250    | 22,727  | 27,982                  | 78,350         | 27,500 | -4,350 | 2,275 | 182,424     |
|           | 1,000      | 4,500    | 18,182  | 22,386                  | 62,680         | 27,500 | -4,350 | 2,150 | 182,424     |
|           | 0,750      | 4,750    | 13,636  | 16,789                  | 47,010         | 27,500 | -4,350 | 2,025 | 182,424     |
|           | 0,500      | 5,000    | 9,091   | 11,193                  | 31,340         | 27,500 | -4,350 | 1,900 | 182,424     |
|           | 0,250      | 5,250    | 4,545   | 5,596                   | 15,670         | 27,500 | -4,350 | 1,775 | 182,424     |
|           | 0,055      | 5,445    | 1,000   | 1,231                   | 3,447          | 27,500 | -4,350 | 1,678 | 182,424     |
|           | 0,000      | 5,500    | 0,000   | 0,000                   | 0,000          | 27,500 | -4,350 | 1,650 | 0,000       |

### Tank Calibrations - MUD 2 ER

Fluid Type = Cement/Mud      Specific gravity = 2,8  
 Permeability = 98 %  
 Trim = 0 m (+ve by stern); Heel = 0 deg to starboard

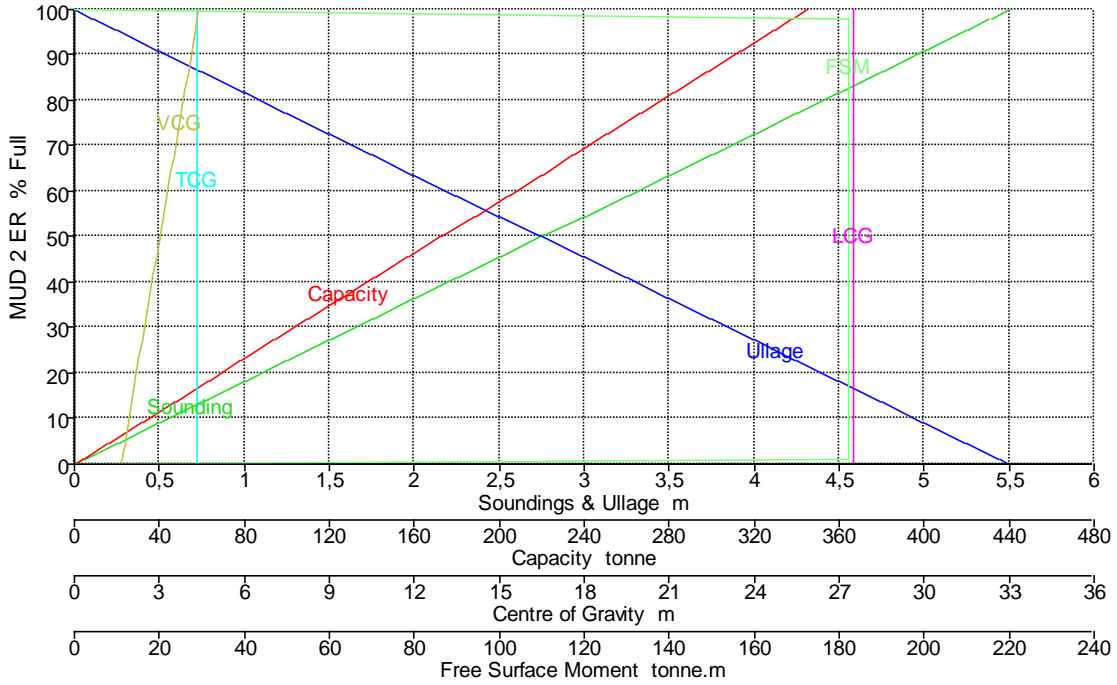

| Tank Name | Sounding m | Ullage m | % Full  | Capacity m <sup>3</sup> | Capacity tonne | LCG m  | TCG m | VCG m | FSM tonne.m |
|-----------|------------|----------|---------|-------------------------|----------------|--------|-------|-------|-------------|
| MUD 2 ER  | 5,500      | 0,000    | 100,000 | 123,122                 | 344,741        | 27,500 | 4,350 | 4,400 | 0,000       |
|           | 5,390      | 0,110    | 98,000  | 120,659                 | 337,846        | 27,500 | 4,350 | 4,345 | 182,424     |
|           | 5,385      | 0,115    | 97,900  | 120,536                 | 337,501        | 27,500 | 4,350 | 4,342 | 182,424     |
|           | 5,250      | 0,250    | 95,455  | 117,525                 | 329,071        | 27,500 | 4,350 | 4,275 | 182,424     |
|           | 5,000      | 0,500    | 90,909  | 111,929                 | 313,401        | 27,500 | 4,350 | 4,150 | 182,424     |
|           | 4,750      | 0,750    | 86,364  | 106,332                 | 297,731        | 27,500 | 4,350 | 4,025 | 182,424     |
|           | 4,500      | 1,000    | 81,818  | 100,736                 | 282,061        | 27,500 | 4,350 | 3,900 | 182,424     |
|           | 4,250      | 1,250    | 77,273  | 95,140                  | 266,391        | 27,500 | 4,350 | 3,775 | 182,424     |
|           | 4,000      | 1,500    | 72,727  | 89,543                  | 250,721        | 27,500 | 4,350 | 3,650 | 182,424     |
|           | 3,750      | 1,750    | 68,182  | 83,947                  | 235,051        | 27,500 | 4,350 | 3,525 | 182,424     |
|           | 3,500      | 2,000    | 63,636  | 78,350                  | 219,381        | 27,500 | 4,350 | 3,400 | 182,424     |
|           | 3,250      | 2,250    | 59,091  | 72,754                  | 203,711        | 27,500 | 4,350 | 3,275 | 182,424     |
|           | 3,000      | 2,500    | 54,545  | 67,157                  | 188,041        | 27,500 | 4,350 | 3,150 | 182,424     |
|           | 2,750      | 2,750    | 50,000  | 61,561                  | 172,370        | 27,500 | 4,350 | 3,025 | 182,424     |
|           | 2,500      | 3,000    | 45,455  | 55,964                  | 156,700        | 27,500 | 4,350 | 2,900 | 182,424     |
|           | 2,250      | 3,250    | 40,909  | 50,368                  | 141,030        | 27,500 | 4,350 | 2,775 | 182,424     |
|           | 2,000      | 3,500    | 36,364  | 44,772                  | 125,360        | 27,500 | 4,350 | 2,650 | 182,424     |
|           | 1,750      | 3,750    | 31,818  | 39,175                  | 109,690        | 27,500 | 4,350 | 2,525 | 182,424     |
|           | 1,500      | 4,000    | 27,273  | 33,579                  | 94,020         | 27,500 | 4,350 | 2,400 | 182,424     |
|           | 1,250      | 4,250    | 22,727  | 27,982                  | 78,350         | 27,500 | 4,350 | 2,275 | 182,424     |
|           | 1,000      | 4,500    | 18,182  | 22,386                  | 62,680         | 27,500 | 4,350 | 2,150 | 182,424     |
|           | 0,750      | 4,750    | 13,636  | 16,789                  | 47,010         | 27,500 | 4,350 | 2,025 | 182,424     |
|           | 0,500      | 5,000    | 9,091   | 11,193                  | 31,340         | 27,500 | 4,350 | 1,900 | 182,424     |
|           | 0,250      | 5,250    | 4,545   | 5,596                   | 15,670         | 27,500 | 4,350 | 1,775 | 182,424     |
|           | 0,055      | 5,445    | 1,000   | 1,231                   | 3,447          | 27,500 | 4,350 | 1,678 | 182,424     |



| Tank Name | Sounding m | Ullage m | % Full | Capacity m <sup>3</sup> | Capacity tonne | LCG m  | TCG m | VCG m | FSM tonne.m |
|-----------|------------|----------|--------|-------------------------|----------------|--------|-------|-------|-------------|
|           | 0,000      | 5,500    | 0,000  | 0,000                   | 0,000          | 27,500 | 4,350 | 1,650 | 0,000       |

### Tank Calibrations - DO/BO 1 BR

Fluid Type = Diesel    Specific gravity = 0,84  
 Permeability = 98 %  
 Trim = 0 m (+ve by stern); Heel = 0 deg to starboard

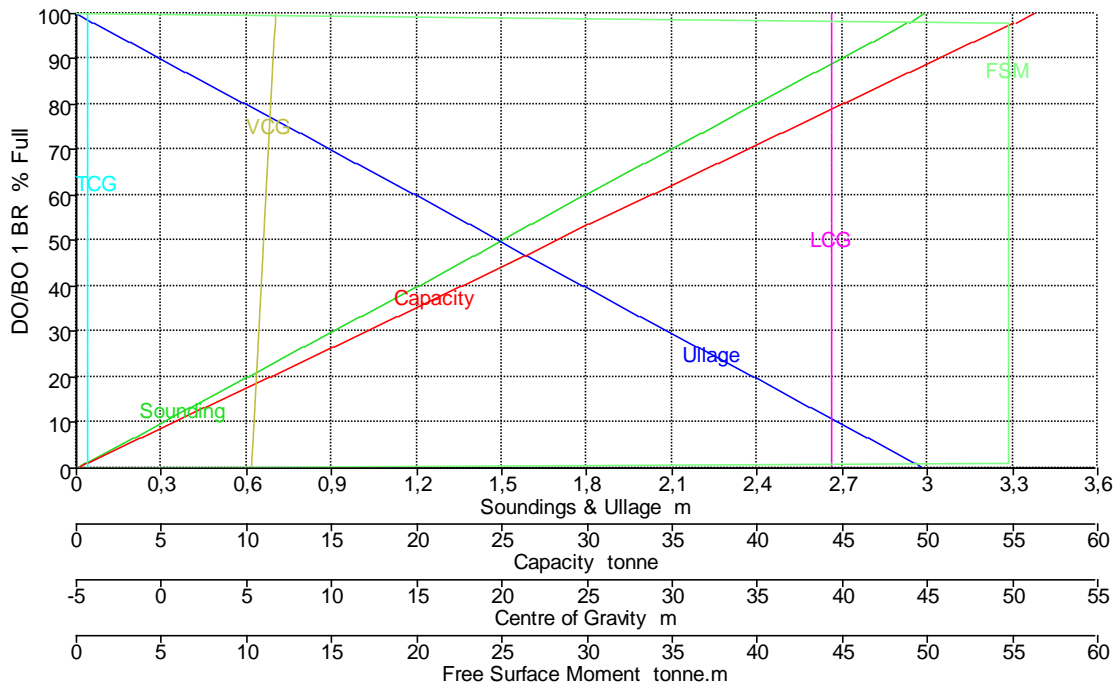

| Tank Name  | Sounding m | Ullage m | % Full  | Capacity m <sup>3</sup> | Capacity tonne | LCG m  | TCG m  | VCG m | FSM tonne.m |
|------------|------------|----------|---------|-------------------------|----------------|--------|--------|-------|-------------|
| DO/BO 1 BR | 2,990      | 0,000    | 100,000 | 66,933                  | 56,224         | 39,400 | -4,350 | 6,745 | 0,000       |
|            | 2,930      | 0,060    | 98,000  | 65,595                  | 55,100         | 39,400 | -4,350 | 6,715 | 54,727      |
|            | 2,927      | 0,063    | 97,900  | 65,528                  | 55,043         | 39,400 | -4,350 | 6,714 | 54,727      |
|            | 2,800      | 0,190    | 93,645  | 62,680                  | 52,651         | 39,400 | -4,350 | 6,650 | 54,727      |
|            | 2,600      | 0,390    | 86,957  | 58,203                  | 48,891         | 39,400 | -4,350 | 6,550 | 54,727      |
|            | 2,400      | 0,590    | 80,268  | 53,726                  | 45,130         | 39,400 | -4,350 | 6,450 | 54,727      |
|            | 2,200      | 0,790    | 73,579  | 49,249                  | 41,369         | 39,400 | -4,350 | 6,350 | 54,727      |
|            | 2,000      | 0,990    | 66,890  | 44,772                  | 37,608         | 39,400 | -4,350 | 6,250 | 54,727      |
|            | 1,800      | 1,190    | 60,201  | 40,294                  | 33,847         | 39,400 | -4,350 | 6,150 | 54,727      |
|            | 1,600      | 1,390    | 53,512  | 35,817                  | 30,086         | 39,400 | -4,350 | 6,050 | 54,727      |
|            | 1,400      | 1,590    | 46,823  | 31,340                  | 26,326         | 39,400 | -4,350 | 5,950 | 54,727      |
|            | 1,200      | 1,790    | 40,134  | 26,863                  | 22,565         | 39,400 | -4,350 | 5,850 | 54,727      |
|            | 1,000      | 1,990    | 33,445  | 22,386                  | 18,804         | 39,400 | -4,350 | 5,750 | 54,727      |
|            | 0,800      | 2,190    | 26,756  | 17,909                  | 15,043         | 39,400 | -4,350 | 5,650 | 54,727      |
|            | 0,600      | 2,390    | 20,067  | 13,431                  | 11,282         | 39,400 | -4,350 | 5,550 | 54,727      |
|            | 0,400      | 2,590    | 13,378  | 8,954                   | 7,522          | 39,400 | -4,350 | 5,450 | 54,727      |
|            | 0,200      | 2,790    | 6,689   | 4,477                   | 3,761          | 39,400 | -4,350 | 5,350 | 54,727      |
|            | 0,030      | 2,960    | 1,000   | 0,669                   | 0,562          | 39,400 | -4,350 | 5,265 | 54,727      |
|            | 0,000      | 2,990    | 0,000   | 0,000                   | 0,000          | 39,400 | -4,350 | 5,250 | 0,000       |

### Tank Calibrations - DO/BO 1 ER

Fluid Type = Diesel      Specific gravity = 0,84  
 Permeability = 98 %  
 Trim = 0 m (+ve by stern); Heel = 0 deg to starboard

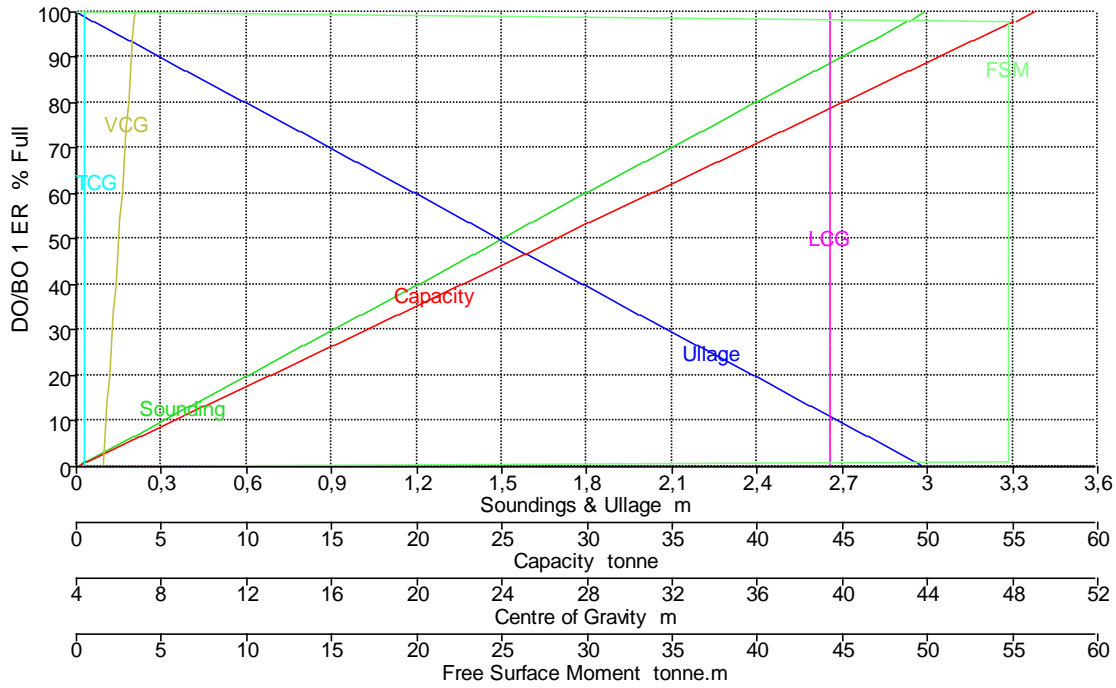

| Tank Name  | Sounding m | Ullage m | % Full  | Capacity m <sup>3</sup> | Capacity tonne | LCG m  | TCG m | VCG m | FSM tonne.m |
|------------|------------|----------|---------|-------------------------|----------------|--------|-------|-------|-------------|
| DO/BO 1 ER | 2,990      | 0,000    | 100,000 | 66,933                  | 56,224         | 39,400 | 4,350 | 6,745 | 0,000       |
|            | 2,930      | 0,060    | 98,000  | 65,595                  | 55,100         | 39,400 | 4,350 | 6,715 | 54,727      |
|            | 2,927      | 0,063    | 97,900  | 65,528                  | 55,043         | 39,400 | 4,350 | 6,714 | 54,727      |
|            | 2,800      | 0,190    | 93,645  | 62,680                  | 52,651         | 39,400 | 4,350 | 6,650 | 54,727      |
|            | 2,600      | 0,390    | 86,957  | 58,203                  | 48,891         | 39,400 | 4,350 | 6,550 | 54,727      |
|            | 2,400      | 0,590    | 80,268  | 53,726                  | 45,130         | 39,400 | 4,350 | 6,450 | 54,727      |
|            | 2,200      | 0,790    | 73,579  | 49,249                  | 41,369         | 39,400 | 4,350 | 6,350 | 54,727      |
|            | 2,000      | 0,990    | 66,890  | 44,772                  | 37,608         | 39,400 | 4,350 | 6,250 | 54,727      |
|            | 1,800      | 1,190    | 60,201  | 40,294                  | 33,847         | 39,400 | 4,350 | 6,150 | 54,727      |
|            | 1,600      | 1,390    | 53,512  | 35,817                  | 30,086         | 39,400 | 4,350 | 6,050 | 54,727      |
|            | 1,400      | 1,590    | 46,823  | 31,340                  | 26,326         | 39,400 | 4,350 | 5,950 | 54,727      |
|            | 1,200      | 1,790    | 40,134  | 26,863                  | 22,565         | 39,400 | 4,350 | 5,850 | 54,727      |
|            | 1,000      | 1,990    | 33,445  | 22,386                  | 18,804         | 39,400 | 4,350 | 5,750 | 54,727      |
|            | 0,800      | 2,190    | 26,756  | 17,909                  | 15,043         | 39,400 | 4,350 | 5,650 | 54,727      |
|            | 0,600      | 2,390    | 20,067  | 13,431                  | 11,282         | 39,400 | 4,350 | 5,550 | 54,727      |
|            | 0,400      | 2,590    | 13,378  | 8,954                   | 7,522          | 39,400 | 4,350 | 5,450 | 54,727      |
|            | 0,200      | 2,790    | 6,689   | 4,477                   | 3,761          | 39,400 | 4,350 | 5,350 | 54,727      |
|            | 0,030      | 2,960    | 1,000   | 0,669                   | 0,562          | 39,400 | 4,350 | 5,265 | 54,727      |
|            | 0,000      | 2,990    | 0,000   | 0,000                   | 0,000          | 39,400 | 4,350 | 5,250 | 0,000       |

**Tank Calibrations - MET BR**

Fluid Type = Metanol      Specific gravity = 0,7918  
 Permeability = 98 %  
 Trim = 0 m (+ve by stern); Heel = 0 deg to starboard

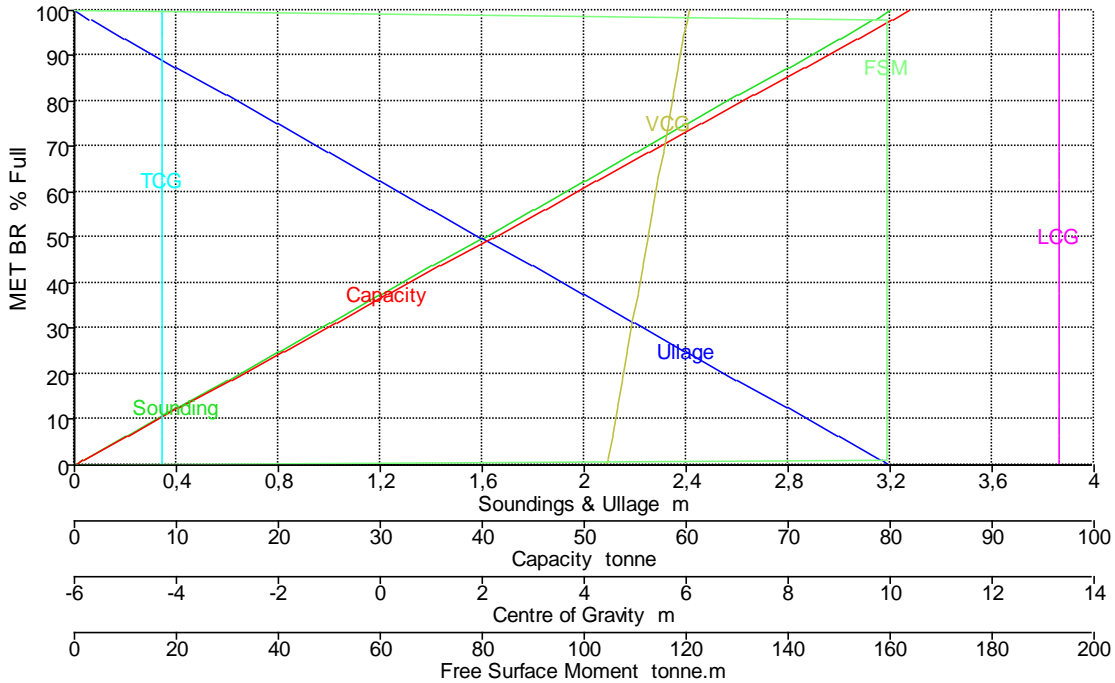

| Tank Name | Sounding m | Ullage m | % Full  | Capacity m <sup>3</sup> | Capacity tonne | LCG m  | TCG m  | VCG m | FSM tonne.m |
|-----------|------------|----------|---------|-------------------------|----------------|--------|--------|-------|-------------|
| MET BR    | 3,200      | 0,000    | 100,000 | 103,350                 | 81,833         | 13,325 | -4,280 | 6,050 | 0,000       |
|           | 3,136      | 0,064    | 98,000  | 101,283                 | 80,196         | 13,325 | -4,280 | 6,018 | 159,337     |
|           | 3,133      | 0,067    | 97,900  | 101,180                 | 80,114         | 13,325 | -4,280 | 6,016 | 159,337     |
|           | 3,000      | 0,200    | 93,750  | 96,891                  | 76,718         | 13,325 | -4,280 | 5,950 | 159,337     |
|           | 2,800      | 0,400    | 87,500  | 90,431                  | 71,603         | 13,325 | -4,280 | 5,850 | 159,337     |
|           | 2,600      | 0,600    | 81,250  | 83,972                  | 66,489         | 13,325 | -4,280 | 5,750 | 159,337     |
|           | 2,400      | 0,800    | 75,000  | 77,513                  | 61,374         | 13,325 | -4,280 | 5,650 | 159,337     |
|           | 2,200      | 1,000    | 68,750  | 71,053                  | 56,260         | 13,325 | -4,280 | 5,550 | 159,337     |
|           | 2,000      | 1,200    | 62,500  | 64,594                  | 51,145         | 13,325 | -4,280 | 5,450 | 159,337     |
|           | 1,800      | 1,400    | 56,250  | 58,134                  | 46,031         | 13,325 | -4,280 | 5,350 | 159,337     |
|           | 1,600      | 1,600    | 50,000  | 51,675                  | 40,916         | 13,325 | -4,280 | 5,250 | 159,337     |
|           | 1,400      | 1,800    | 43,750  | 45,216                  | 35,802         | 13,325 | -4,280 | 5,150 | 159,337     |
|           | 1,200      | 2,000    | 37,500  | 38,756                  | 30,687         | 13,325 | -4,280 | 5,050 | 159,337     |
|           | 1,000      | 2,200    | 31,250  | 32,297                  | 25,573         | 13,325 | -4,280 | 4,950 | 159,337     |
|           | 0,800      | 2,400    | 25,000  | 25,838                  | 20,458         | 13,325 | -4,280 | 4,850 | 159,337     |
|           | 0,600      | 2,600    | 18,750  | 19,378                  | 15,344         | 13,325 | -4,280 | 4,750 | 159,337     |
|           | 0,400      | 2,800    | 12,500  | 12,919                  | 10,229         | 13,325 | -4,280 | 4,650 | 159,337     |
|           | 0,200      | 3,000    | 6,250   | 6,459                   | 5,115          | 13,325 | -4,280 | 4,550 | 159,337     |
|           | 0,032      | 3,168    | 1,000   | 1,034                   | 0,818          | 13,325 | -4,280 | 4,466 | 159,337     |
|           | 0,000      | 3,200    | 0,000   | 0,000                   | 0,000          | 13,325 | -4,280 | 4,450 | 0,000       |

**Tank Calibrations - MET ER**

Fluid Type = Metanol      Specific gravity = 0,7918  
 Permeability = 98 %  
 Trim = 0 m (+ve by stern); Heel = 0 deg to starboard

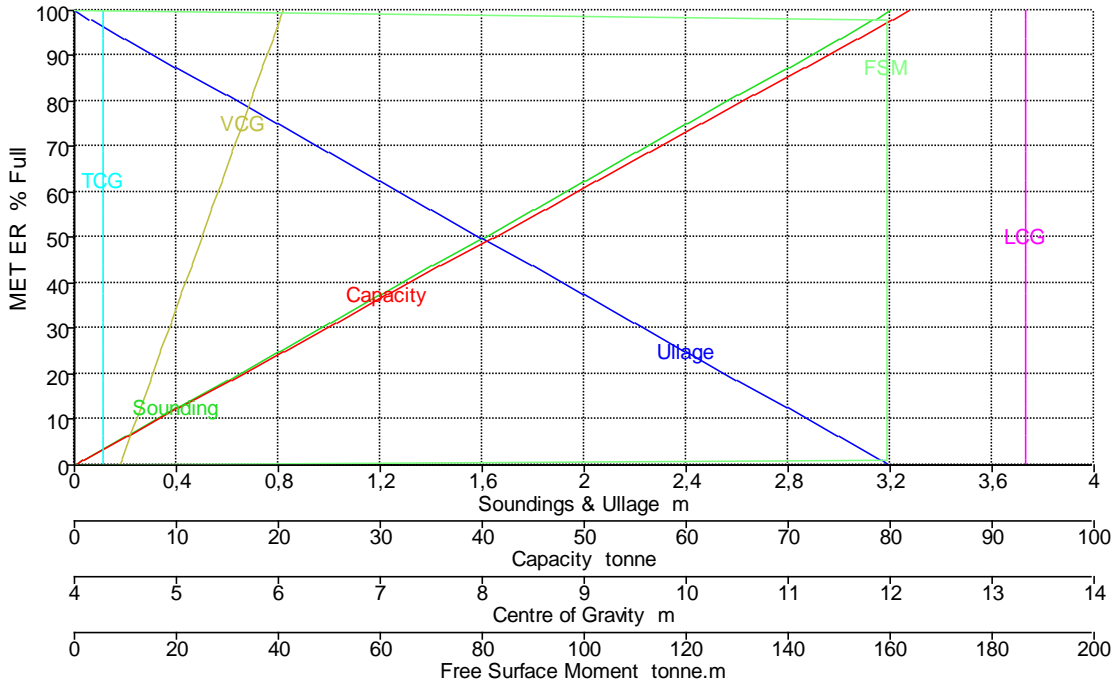

| Tank Name | Sounding m | Ullage m | % Full  | Capacity m <sup>3</sup> | Capacity tonne | LCG m  | TCG m | VCG m | FSM tonne.m |
|-----------|------------|----------|---------|-------------------------|----------------|--------|-------|-------|-------------|
| MET ER    | 3,200      | 0,000    | 100,000 | 103,350                 | 81,833         | 13,325 | 4,280 | 6,050 | 0,000       |
|           | 3,136      | 0,064    | 98,000  | 101,283                 | 80,196         | 13,325 | 4,280 | 6,018 | 159,337     |
|           | 3,133      | 0,067    | 97,900  | 101,180                 | 80,114         | 13,325 | 4,280 | 6,016 | 159,337     |
|           | 3,000      | 0,200    | 93,750  | 96,891                  | 76,718         | 13,325 | 4,280 | 5,950 | 159,337     |
|           | 2,800      | 0,400    | 87,500  | 90,431                  | 71,603         | 13,325 | 4,280 | 5,850 | 159,337     |
|           | 2,600      | 0,600    | 81,250  | 83,972                  | 66,489         | 13,325 | 4,280 | 5,750 | 159,337     |
|           | 2,400      | 0,800    | 75,000  | 77,513                  | 61,374         | 13,325 | 4,280 | 5,650 | 159,337     |
|           | 2,200      | 1,000    | 68,750  | 71,053                  | 56,260         | 13,325 | 4,280 | 5,550 | 159,337     |
|           | 2,000      | 1,200    | 62,500  | 64,594                  | 51,145         | 13,325 | 4,280 | 5,450 | 159,337     |
|           | 1,800      | 1,400    | 56,250  | 58,134                  | 46,031         | 13,325 | 4,280 | 5,350 | 159,337     |
|           | 1,600      | 1,600    | 50,000  | 51,675                  | 40,916         | 13,325 | 4,280 | 5,250 | 159,337     |
|           | 1,400      | 1,800    | 43,750  | 45,216                  | 35,802         | 13,325 | 4,280 | 5,150 | 159,337     |
|           | 1,200      | 2,000    | 37,500  | 38,756                  | 30,687         | 13,325 | 4,280 | 5,050 | 159,337     |
|           | 1,000      | 2,200    | 31,250  | 32,297                  | 25,573         | 13,325 | 4,280 | 4,950 | 159,337     |
|           | 0,800      | 2,400    | 25,000  | 25,838                  | 20,458         | 13,325 | 4,280 | 4,850 | 159,337     |
|           | 0,600      | 2,600    | 18,750  | 19,378                  | 15,344         | 13,325 | 4,280 | 4,750 | 159,337     |
|           | 0,400      | 2,800    | 12,500  | 12,919                  | 10,229         | 13,325 | 4,280 | 4,650 | 159,337     |
|           | 0,200      | 3,000    | 6,250   | 6,459                   | 5,115          | 13,325 | 4,280 | 4,550 | 159,337     |
|           | 0,032      | 3,168    | 1,000   | 1,034                   | 0,818          | 13,325 | 4,280 | 4,466 | 159,337     |
|           | 0,000      | 3,200    | 0,000   | 0,000                   | 0,000          | 13,325 | 4,280 | 4,450 | 0,000       |

**Tank Calibrations - BO/SP BR**

Fluid Type = Specific gravity = 1  
 Permeability = 98 %  
 Trim = 0 m (+ve by stern); Heel = 0 deg to starboard

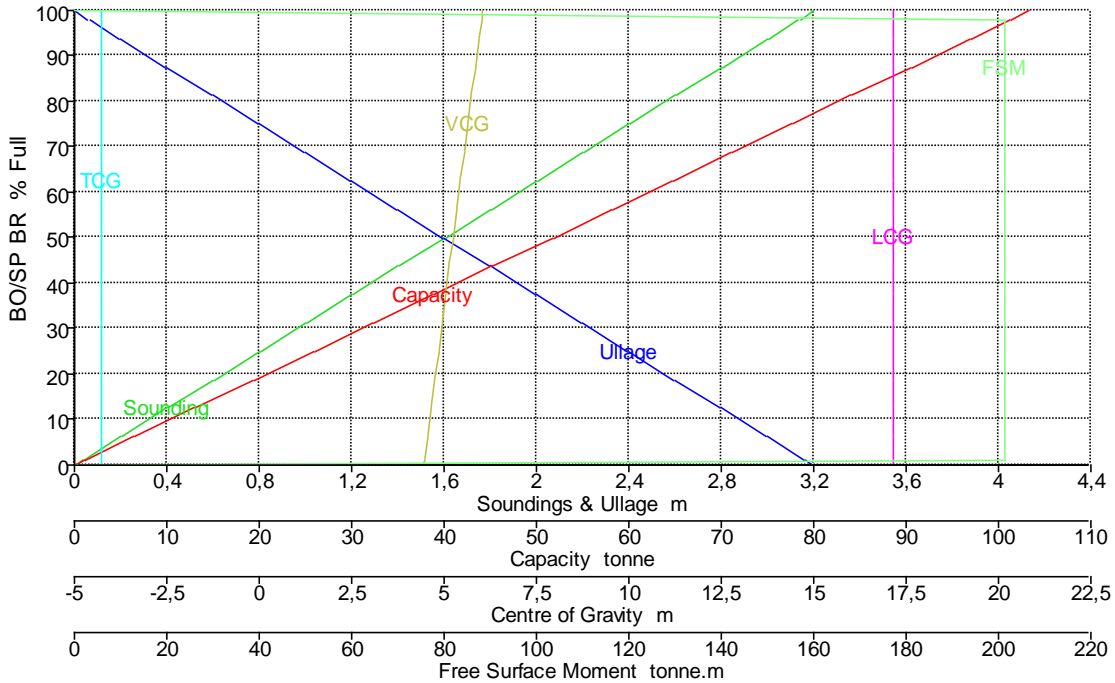

| Tank Name | Sounding m | Ullage m | % Full  | Capacity m <sup>3</sup> | Capacity tonne | LCG m  | TCG m  | VCG m | FSM tonne.m |
|-----------|------------|----------|---------|-------------------------|----------------|--------|--------|-------|-------------|
| BO/SP BR  | 3,200      | 0,000    | 100,000 | 103,350                 | 103,350        | 17,175 | -4,280 | 6,050 | 0,000       |
|           | 3,136      | 0,064    | 98,000  | 101,283                 | 101,283        | 17,175 | -4,280 | 6,018 | 201,234     |
|           | 3,133      | 0,067    | 97,900  | 101,180                 | 101,180        | 17,175 | -4,280 | 6,016 | 201,234     |
|           | 3,000      | 0,200    | 93,750  | 96,891                  | 96,891         | 17,175 | -4,280 | 5,950 | 201,234     |
|           | 2,800      | 0,400    | 87,500  | 90,431                  | 90,431         | 17,175 | -4,280 | 5,850 | 201,234     |
|           | 2,600      | 0,600    | 81,250  | 83,972                  | 83,972         | 17,175 | -4,280 | 5,750 | 201,234     |
|           | 2,400      | 0,800    | 75,000  | 77,513                  | 77,513         | 17,175 | -4,280 | 5,650 | 201,234     |
|           | 2,200      | 1,000    | 68,750  | 71,053                  | 71,053         | 17,175 | -4,280 | 5,550 | 201,234     |
|           | 2,000      | 1,200    | 62,500  | 64,594                  | 64,594         | 17,175 | -4,280 | 5,450 | 201,234     |
|           | 1,800      | 1,400    | 56,250  | 58,134                  | 58,134         | 17,175 | -4,280 | 5,350 | 201,234     |
|           | 1,600      | 1,600    | 50,000  | 51,675                  | 51,675         | 17,175 | -4,280 | 5,250 | 201,234     |
|           | 1,400      | 1,800    | 43,750  | 45,216                  | 45,216         | 17,175 | -4,280 | 5,150 | 201,234     |
|           | 1,200      | 2,000    | 37,500  | 38,756                  | 38,756         | 17,175 | -4,280 | 5,050 | 201,234     |
|           | 1,000      | 2,200    | 31,250  | 32,297                  | 32,297         | 17,175 | -4,280 | 4,950 | 201,234     |
|           | 0,800      | 2,400    | 25,000  | 25,838                  | 25,838         | 17,175 | -4,280 | 4,850 | 201,234     |
|           | 0,600      | 2,600    | 18,750  | 19,378                  | 19,378         | 17,175 | -4,280 | 4,750 | 201,234     |
|           | 0,400      | 2,800    | 12,500  | 12,919                  | 12,919         | 17,175 | -4,280 | 4,650 | 201,234     |
|           | 0,200      | 3,000    | 6,250   | 6,459                   | 6,459          | 17,175 | -4,280 | 4,550 | 201,234     |
|           | 0,032      | 3,168    | 1,000   | 1,034                   | 1,034          | 17,175 | -4,280 | 4,466 | 201,234     |
|           | 0,000      | 3,200    | 0,000   | 0,000                   | 0,000          | 17,175 | -4,280 | 4,450 | 0,000       |

### Tank Calibrations - BO/SP ER

Fluid Type = Specific gravity = 1  
 Permeability = 98 %  
 Trim = 0 m (+ve by stern); Heel = 0 deg to starboard

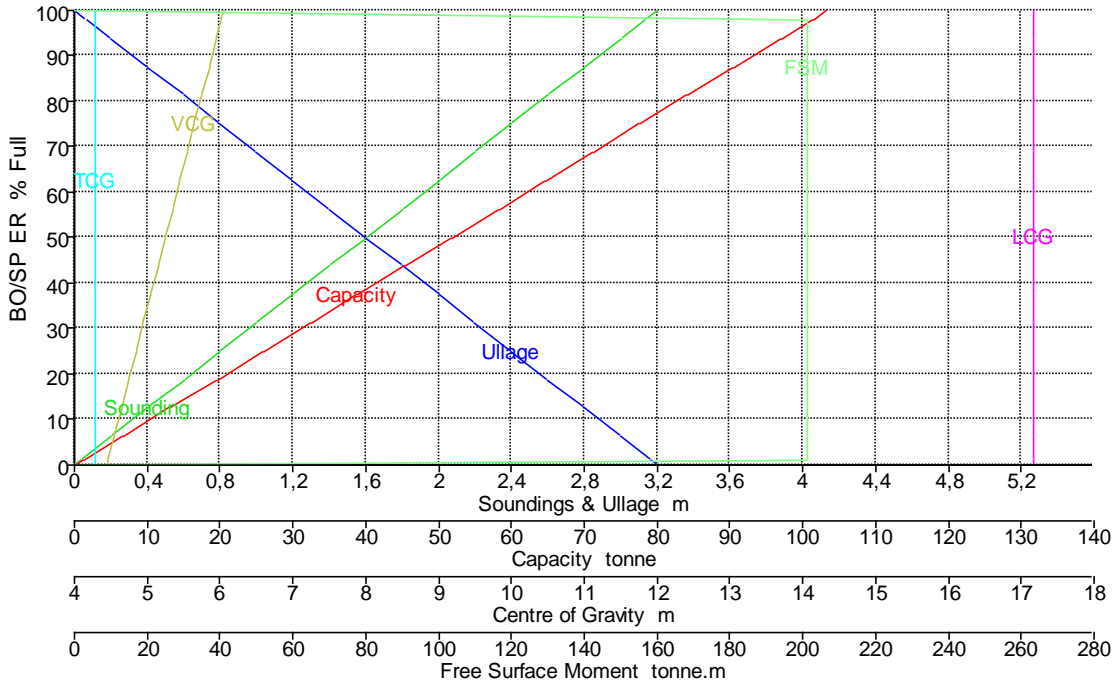

| Tank Name | Sounding m | Ullage m | % Full  | Capacity m <sup>3</sup> | Capacity tonne | LCG m  | TCG m | VCG m | FSM tonne.m |
|-----------|------------|----------|---------|-------------------------|----------------|--------|-------|-------|-------------|
| BO/SP ER  | 3,200      | 0,000    | 100,000 | 103,350                 | 103,350        | 17,175 | 4,280 | 6,050 | 0,000       |
|           | 3,136      | 0,064    | 98,000  | 101,283                 | 101,283        | 17,175 | 4,280 | 6,018 | 201,234     |
|           | 3,133      | 0,067    | 97,900  | 101,180                 | 101,180        | 17,175 | 4,280 | 6,016 | 201,234     |
|           | 3,000      | 0,200    | 93,750  | 96,891                  | 96,891         | 17,175 | 4,280 | 5,950 | 201,234     |
|           | 2,800      | 0,400    | 87,500  | 90,431                  | 90,431         | 17,175 | 4,280 | 5,850 | 201,234     |
|           | 2,600      | 0,600    | 81,250  | 83,972                  | 83,972         | 17,175 | 4,280 | 5,750 | 201,234     |
|           | 2,400      | 0,800    | 75,000  | 77,513                  | 77,513         | 17,175 | 4,280 | 5,650 | 201,234     |
|           | 2,200      | 1,000    | 68,750  | 71,053                  | 71,053         | 17,175 | 4,280 | 5,550 | 201,234     |
|           | 2,000      | 1,200    | 62,500  | 64,594                  | 64,594         | 17,175 | 4,280 | 5,450 | 201,234     |
|           | 1,800      | 1,400    | 56,250  | 58,134                  | 58,134         | 17,175 | 4,280 | 5,350 | 201,234     |
|           | 1,600      | 1,600    | 50,000  | 51,675                  | 51,675         | 17,175 | 4,280 | 5,250 | 201,234     |
|           | 1,400      | 1,800    | 43,750  | 45,216                  | 45,216         | 17,175 | 4,280 | 5,150 | 201,234     |
|           | 1,200      | 2,000    | 37,500  | 38,756                  | 38,756         | 17,175 | 4,280 | 5,050 | 201,234     |
|           | 1,000      | 2,200    | 31,250  | 32,297                  | 32,297         | 17,175 | 4,280 | 4,950 | 201,234     |
|           | 0,800      | 2,400    | 25,000  | 25,838                  | 25,838         | 17,175 | 4,280 | 4,850 | 201,234     |
|           | 0,600      | 2,600    | 18,750  | 19,378                  | 19,378         | 17,175 | 4,280 | 4,750 | 201,234     |
|           | 0,400      | 2,800    | 12,500  | 12,919                  | 12,919         | 17,175 | 4,280 | 4,650 | 201,234     |
|           | 0,200      | 3,000    | 6,250   | 6,459                   | 6,459          | 17,175 | 4,280 | 4,550 | 201,234     |
|           | 0,032      | 3,168    | 1,000   | 1,034                   | 1,034          | 17,175 | 4,280 | 4,466 | 201,234     |
|           | 0,000      | 3,200    | 0,000   | 0,000                   | 0,000          | 17,175 | 4,280 | 4,450 | 0,000       |

### Tank Calibrations - WB 1 BR

Fluid Type = Water Ballast      Specific gravity = 1,025  
 Permeability = 100 %  
 Trim = 0 m (+ve by stern); Heel = 0 deg to starboard

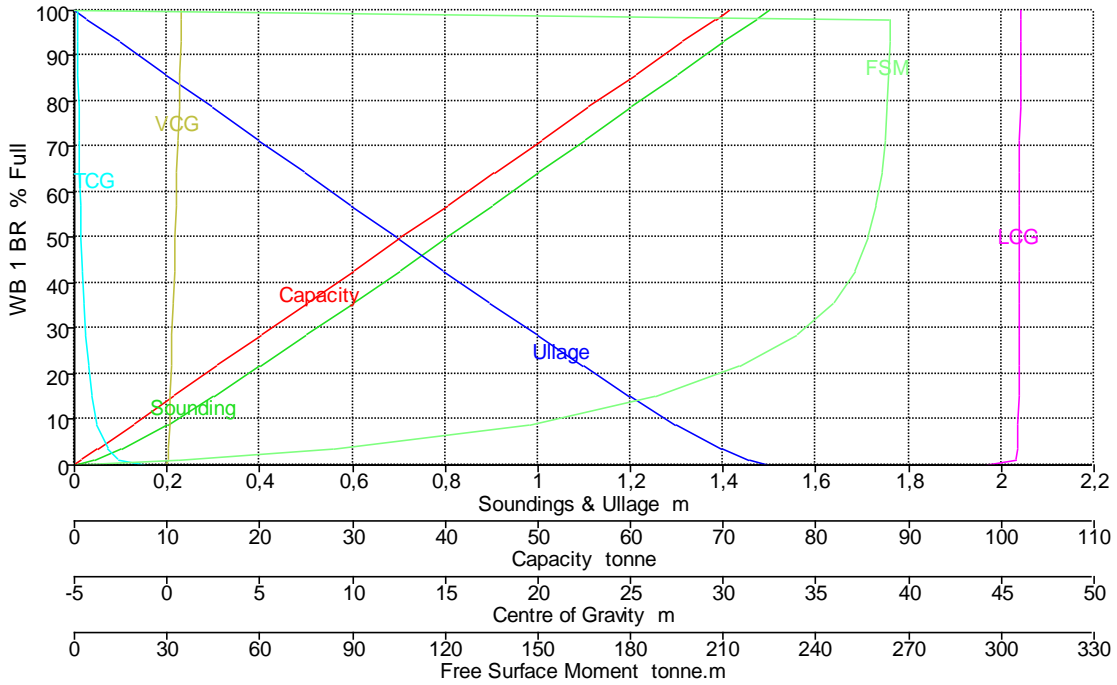

| Tank Name | Sounding m | Ullage m | % Full  | Capacity m <sup>3</sup> | Capacity tonne | LCG m  | TCG m  | VCG m | FSM tonne.m |
|-----------|------------|----------|---------|-------------------------|----------------|--------|--------|-------|-------------|
| WB 1 BR   | 1,499      | 0,000    | 100,000 | 68,859                  | 70,580         | 46,014 | -4,836 | 0,797 | 0,000       |
|           | 1,471      | 0,028    | 98,000  | 67,482                  | 69,169         | 46,014 | -4,832 | 0,783 | 264,255     |
|           | 1,470      | 0,029    | 97,900  | 67,413                  | 69,098         | 46,013 | -4,832 | 0,782 | 264,251     |
|           | 1,400      | 0,099    | 92,877  | 63,954                  | 65,553         | 46,012 | -4,820 | 0,747 | 264,017     |
|           | 1,300      | 0,199    | 85,663  | 58,987                  | 60,461         | 46,009 | -4,802 | 0,696 | 263,645     |
|           | 1,200      | 0,299    | 78,453  | 54,022                  | 55,373         | 46,006 | -4,780 | 0,645 | 263,056     |
|           | 1,100      | 0,399    | 71,250  | 49,062                  | 50,289         | 46,002 | -4,754 | 0,594 | 262,254     |
|           | 1,000      | 0,499    | 64,056  | 44,108                  | 45,211         | 45,998 | -4,723 | 0,543 | 261,215     |
|           | 0,900      | 0,599    | 56,874  | 39,163                  | 40,142         | 45,993 | -4,684 | 0,491 | 259,479     |
|           | 0,800      | 0,699    | 49,713  | 34,231                  | 35,087         | 45,988 | -4,637 | 0,439 | 256,904     |
|           | 0,700      | 0,799    | 42,583  | 29,322                  | 30,055         | 45,982 | -4,576 | 0,387 | 252,742     |
|           | 0,600      | 0,899    | 35,507  | 24,449                  | 25,061         | 45,975 | -4,498 | 0,334 | 245,664     |
|           | 0,500      | 0,999    | 28,524  | 19,642                  | 20,133         | 45,967 | -4,396 | 0,281 | 233,325     |
|           | 0,400      | 1,099    | 21,695  | 14,939                  | 15,313         | 45,956 | -4,257 | 0,227 | 215,039     |
|           | 0,300      | 1,199    | 15,106  | 10,402                  | 10,662         | 45,940 | -4,062 | 0,172 | 187,898     |
|           | 0,200      | 1,299    | 8,914   | 6,138                   | 6,291          | 45,913 | -3,763 | 0,117 | 146,724     |
|           | 0,100      | 1,399    | 3,456   | 2,379                   | 2,439          | 45,860 | -3,229 | 0,061 | 83,627      |
|           | 0,043      | 1,456    | 1,000   | 0,689                   | 0,706          | 45,777 | -2,607 | 0,027 | 33,380      |
|           | 0,000      | 1,499    | 0,000   | 0,000                   | 0,000          | 44,175 | -1,105 | 0,001 | 0,000       |

### Tank Calibrations - WB 1 ER

Fluid Type = Water Ballast      Specific gravity = 1,025

Permeability = 100 %

Trim = 0 m (+ve by stern); Heel = 0 deg to starboard

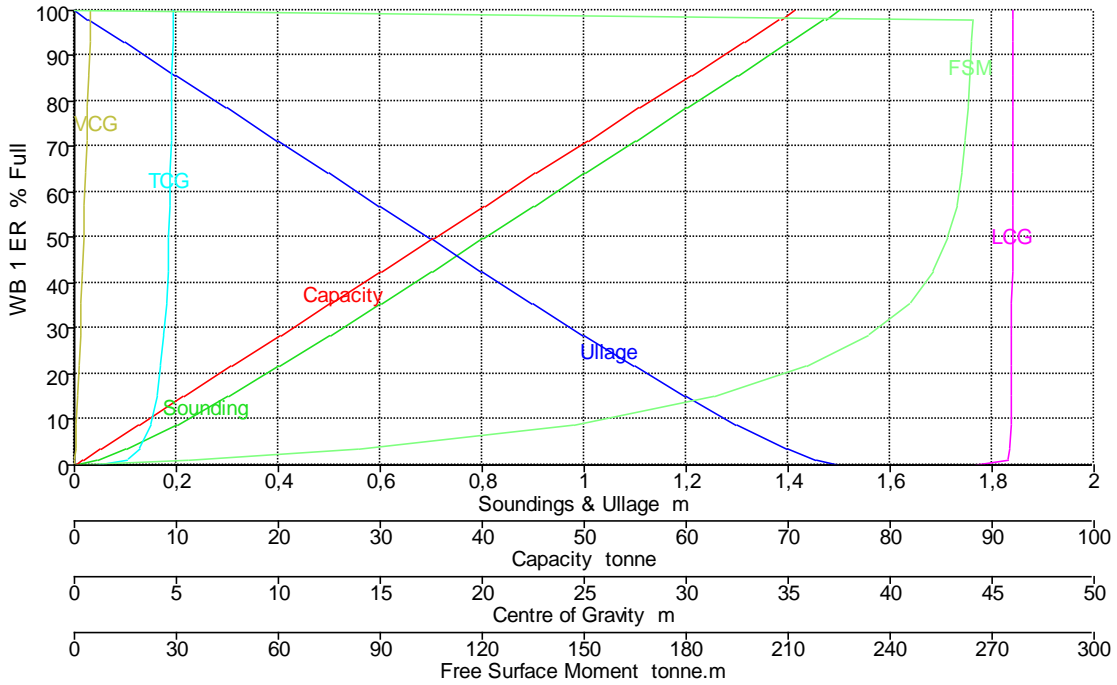

| Tank Name | Sounding m | Ullage m | % Full  | Capacity m <sup>3</sup> | Capacity tonne | LCG m  | TCG m | VCG m | FSM tonne.m |
|-----------|------------|----------|---------|-------------------------|----------------|--------|-------|-------|-------------|
| WB 1 ER   | 1,499      | 0,000    | 100,000 | 68,859                  | 70,580         | 46,014 | 4,836 | 0,797 | 0,000       |
|           | 1,471      | 0,028    | 98,000  | 67,482                  | 69,169         | 46,014 | 4,832 | 0,783 | 264,255     |
|           | 1,470      | 0,029    | 97,900  | 67,413                  | 69,098         | 46,013 | 4,832 | 0,782 | 264,251     |
|           | 1,400      | 0,099    | 92,877  | 63,954                  | 65,553         | 46,012 | 4,820 | 0,747 | 264,017     |
|           | 1,300      | 0,199    | 85,663  | 58,987                  | 60,461         | 46,009 | 4,802 | 0,696 | 263,645     |
|           | 1,200      | 0,299    | 78,453  | 54,022                  | 55,373         | 46,006 | 4,780 | 0,645 | 263,056     |
|           | 1,100      | 0,399    | 71,250  | 49,062                  | 50,289         | 46,002 | 4,754 | 0,594 | 262,254     |
|           | 1,000      | 0,499    | 64,056  | 44,108                  | 45,211         | 45,998 | 4,723 | 0,543 | 261,215     |
|           | 0,900      | 0,599    | 56,874  | 39,163                  | 40,142         | 45,993 | 4,684 | 0,491 | 259,479     |
|           | 0,800      | 0,699    | 49,713  | 34,231                  | 35,087         | 45,988 | 4,637 | 0,439 | 256,904     |
|           | 0,700      | 0,799    | 42,583  | 29,322                  | 30,055         | 45,982 | 4,576 | 0,387 | 252,742     |
|           | 0,600      | 0,899    | 35,507  | 24,449                  | 25,061         | 45,975 | 4,498 | 0,334 | 245,664     |
|           | 0,500      | 0,999    | 28,524  | 19,642                  | 20,133         | 45,967 | 4,396 | 0,281 | 233,325     |
|           | 0,400      | 1,099    | 21,695  | 14,939                  | 15,313         | 45,956 | 4,257 | 0,227 | 215,039     |
|           | 0,300      | 1,199    | 15,106  | 10,402                  | 10,662         | 45,940 | 4,062 | 0,172 | 187,898     |
|           | 0,200      | 1,299    | 8,914   | 6,138                   | 6,291          | 45,913 | 3,763 | 0,117 | 146,724     |
|           | 0,100      | 1,399    | 3,456   | 2,379                   | 2,439          | 45,860 | 3,229 | 0,061 | 83,627      |
|           | 0,043      | 1,456    | 1,000   | 0,689                   | 0,706          | 45,777 | 2,607 | 0,027 | 33,380      |
|           | 0,000      | 1,499    | 0,000   | 0,000                   | 0,000          | 44,175 | 1,105 | 0,001 | 0,000       |

### Tank Calibrations - WB 2 BR

Fluid Type = Water Ballast      Specific gravity = 1,025

Permeability = 100 %

Trim = 0 m (+ve by stern); Heel = 0 deg to starboard



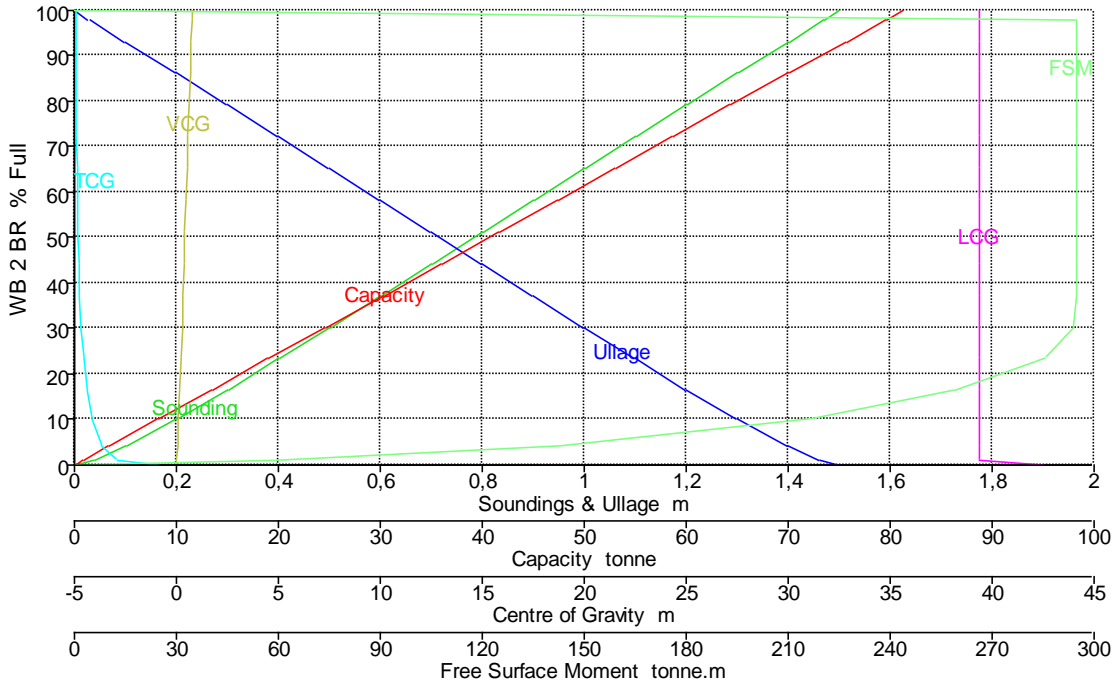

| Tank Name | Sounding m | Ullage m | % Full  | Capacity m <sup>3</sup> | Capacity tonne | LCG m  | TCG m  | VCG m | FSM tonne.m |
|-----------|------------|----------|---------|-------------------------|----------------|--------|--------|-------|-------------|
| WB 2 BR   | 1,499      | 0,000    | 100,000 | 79,226                  | 81,207         | 39,393 | -4,933 | 0,781 | 0,000       |
|           | 1,470      | 0,029    | 98,000  | 77,642                  | 79,583         | 39,393 | -4,930 | 0,766 | 294,796     |
|           | 1,468      | 0,030    | 97,900  | 77,562                  | 79,501         | 39,393 | -4,930 | 0,766 | 294,796     |
|           | 1,400      | 0,099    | 93,120  | 73,776                  | 75,620         | 39,393 | -4,924 | 0,731 | 294,796     |
|           | 1,300      | 0,199    | 86,140  | 68,246                  | 69,952         | 39,392 | -4,914 | 0,681 | 294,796     |
|           | 1,200      | 0,299    | 79,160  | 62,716                  | 64,284         | 39,391 | -4,902 | 0,631 | 294,796     |
|           | 1,100      | 0,399    | 72,180  | 57,186                  | 58,615         | 39,390 | -4,888 | 0,580 | 294,796     |
|           | 1,000      | 0,499    | 65,200  | 51,656                  | 52,947         | 39,389 | -4,870 | 0,530 | 294,796     |
|           | 0,900      | 0,599    | 58,220  | 46,126                  | 47,279         | 39,388 | -4,849 | 0,479 | 294,796     |
|           | 0,800      | 0,699    | 51,240  | 40,596                  | 41,611         | 39,386 | -4,821 | 0,429 | 294,796     |
|           | 0,700      | 0,799    | 44,260  | 35,066                  | 35,942         | 39,384 | -4,785 | 0,378 | 294,796     |
|           | 0,600      | 0,899    | 37,280  | 29,536                  | 30,274         | 39,381 | -4,735 | 0,326 | 294,796     |
|           | 0,500      | 0,999    | 30,302  | 24,007                  | 24,607         | 39,377 | -4,663 | 0,275 | 294,019     |
|           | 0,400      | 1,099    | 23,353  | 18,501                  | 18,964         | 39,373 | -4,553 | 0,222 | 285,259     |
|           | 0,300      | 1,199    | 16,551  | 13,113                  | 13,441         | 39,370 | -4,390 | 0,169 | 258,611     |
|           | 0,200      | 1,299    | 10,046  | 7,959                   | 8,158          | 39,366 | -4,136 | 0,115 | 215,921     |
|           | 0,100      | 1,399    | 4,107   | 3,254                   | 3,335          | 39,366 | -3,657 | 0,060 | 142,190     |
|           | 0,037      | 1,462    | 1,000   | 0,792                   | 0,812          | 39,412 | -2,927 | 0,024 | 59,197      |
|           | 0,000      | 1,499    | 0,000   | 0,000                   | 0,000          | 42,604 | -0,756 | 0,001 | 0,000       |

### Tank Calibrations - WB 2 ER

Fluid Type = Water Ballast      Specific gravity = 1,025

Permeability = 100 %

Trim = 0 m (+ve by stern); Heel = 0 deg to starboard

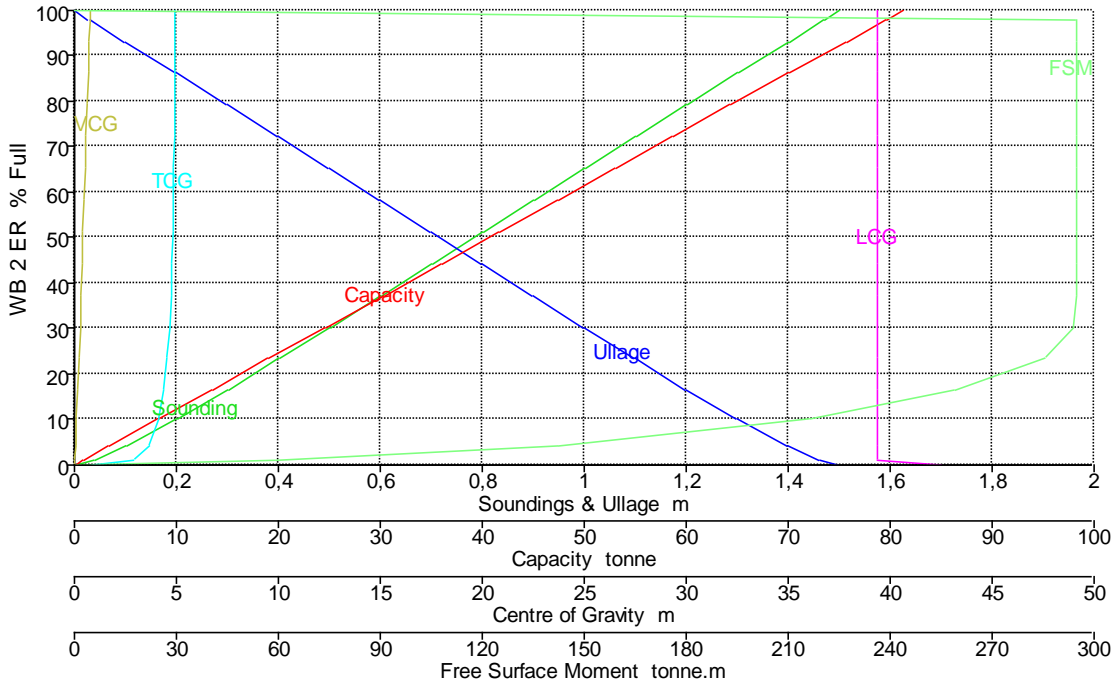

| Tank Name | Sounding m | Ullage m | % Full  | Capacity m <sup>3</sup> | Capacity tonne | LCG m  | TCG m | VCG m | FSM tonne.m |
|-----------|------------|----------|---------|-------------------------|----------------|--------|-------|-------|-------------|
| WB 2 ER   | 1,499      | 0,000    | 100,000 | 79,226                  | 81,207         | 39,393 | 4,933 | 0,781 | 0,000       |
|           | 1,470      | 0,029    | 98,000  | 77,642                  | 79,583         | 39,393 | 4,930 | 0,766 | 294,796     |
|           | 1,468      | 0,030    | 97,900  | 77,562                  | 79,501         | 39,393 | 4,930 | 0,766 | 294,796     |
|           | 1,400      | 0,099    | 93,120  | 73,776                  | 75,620         | 39,393 | 4,924 | 0,731 | 294,796     |
|           | 1,300      | 0,199    | 86,140  | 68,246                  | 69,952         | 39,392 | 4,914 | 0,681 | 294,796     |
|           | 1,200      | 0,299    | 79,160  | 62,716                  | 64,284         | 39,391 | 4,902 | 0,631 | 294,796     |
|           | 1,100      | 0,399    | 72,180  | 57,186                  | 58,615         | 39,390 | 4,888 | 0,580 | 294,796     |
|           | 1,000      | 0,499    | 65,200  | 51,656                  | 52,947         | 39,389 | 4,870 | 0,530 | 294,796     |
|           | 0,900      | 0,599    | 58,220  | 46,126                  | 47,279         | 39,388 | 4,849 | 0,479 | 294,796     |
|           | 0,800      | 0,699    | 51,240  | 40,596                  | 41,611         | 39,386 | 4,821 | 0,429 | 294,796     |
|           | 0,700      | 0,799    | 44,260  | 35,066                  | 35,942         | 39,384 | 4,785 | 0,378 | 294,796     |
|           | 0,600      | 0,899    | 37,280  | 29,536                  | 30,274         | 39,381 | 4,735 | 0,326 | 294,796     |
|           | 0,500      | 0,999    | 30,302  | 24,007                  | 24,607         | 39,377 | 4,663 | 0,275 | 294,019     |
|           | 0,400      | 1,099    | 23,353  | 18,501                  | 18,964         | 39,373 | 4,553 | 0,222 | 285,259     |
|           | 0,300      | 1,199    | 16,551  | 13,113                  | 13,441         | 39,370 | 4,390 | 0,169 | 258,611     |
|           | 0,200      | 1,299    | 10,046  | 7,959                   | 8,158          | 39,366 | 4,136 | 0,115 | 215,921     |
|           | 0,100      | 1,399    | 4,107   | 3,254                   | 3,335          | 39,366 | 3,657 | 0,060 | 142,190     |
|           | 0,037      | 1,462    | 1,000   | 0,792                   | 0,812          | 39,412 | 2,927 | 0,024 | 59,197      |
|           | 0,000      | 1,499    | 0,000   | 0,000                   | 0,000          | 42,604 | 0,756 | 0,001 | 0,000       |

### Tank Calibrations - WB 3 BR

Fluid Type = Water Ballast      Specific gravity = 1,025

Permeability = 100 %

Trim = 0 m (+ve by stern); Heel = 0 deg to starboard

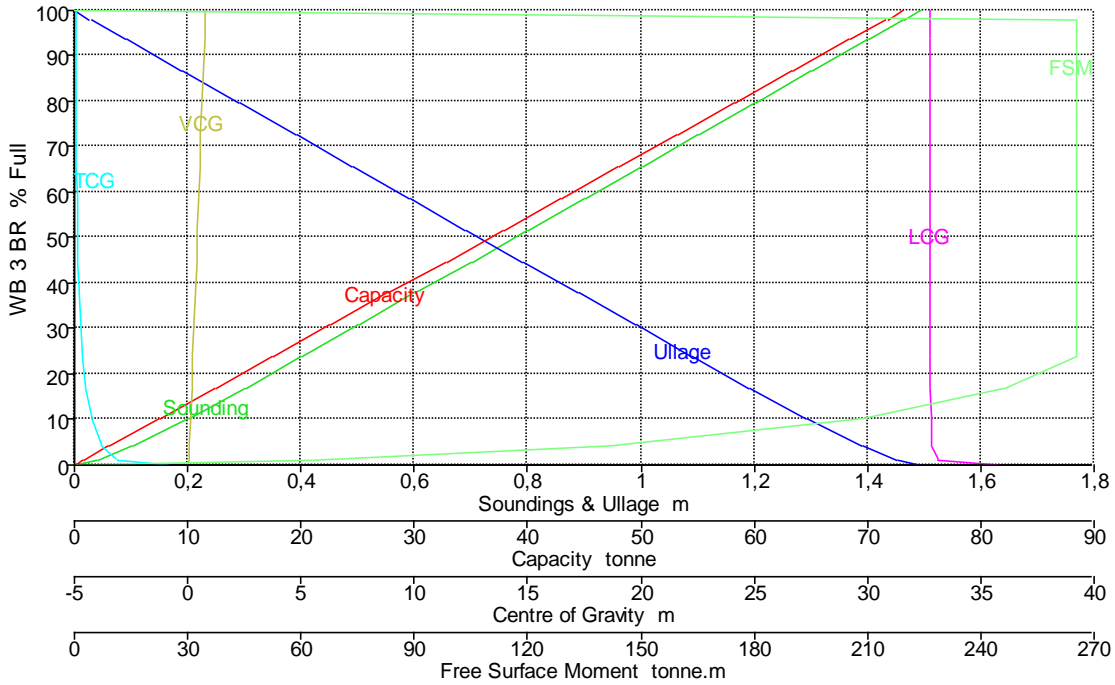

| Tank Name | Sounding m | Ullage m | % Full  | Capacity m <sup>3</sup> | Capacity tonne | LCG m  | TCG m  | VCG m | FSM tonne.m |
|-----------|------------|----------|---------|-------------------------|----------------|--------|--------|-------|-------------|
| WB 3 BR   | 1,492      | 0,000    | 100,000 | 71,340                  | 73,123         | 32,755 | -4,952 | 0,781 | 0,000       |
|           | 1,464      | 0,029    | 98,000  | 69,913                  | 71,661         | 32,755 | -4,950 | 0,767 | 265,317     |
|           | 1,462      | 0,030    | 97,900  | 69,842                  | 71,588         | 32,755 | -4,950 | 0,766 | 265,317     |
|           | 1,400      | 0,092    | 93,549  | 66,737                  | 68,406         | 32,755 | -4,946 | 0,735 | 265,317     |
|           | 1,300      | 0,192    | 86,572  | 61,760                  | 63,304         | 32,755 | -4,937 | 0,685 | 265,317     |
|           | 1,200      | 0,292    | 79,596  | 56,783                  | 58,203         | 32,756 | -4,927 | 0,634 | 265,317     |
|           | 1,100      | 0,392    | 72,619  | 51,806                  | 53,102         | 32,756 | -4,916 | 0,584 | 265,317     |
|           | 1,000      | 0,492    | 65,643  | 46,829                  | 48,000         | 32,757 | -4,901 | 0,534 | 265,317     |
|           | 0,900      | 0,592    | 58,666  | 41,852                  | 42,899         | 32,758 | -4,884 | 0,484 | 265,317     |
|           | 0,800      | 0,692    | 51,690  | 36,875                  | 37,797         | 32,759 | -4,861 | 0,433 | 265,317     |
|           | 0,700      | 0,792    | 44,713  | 31,898                  | 32,696         | 32,760 | -4,832 | 0,382 | 265,317     |
|           | 0,600      | 0,892    | 37,737  | 26,921                  | 27,595         | 32,762 | -4,791 | 0,332 | 265,317     |
|           | 0,500      | 0,992    | 30,760  | 21,944                  | 22,493         | 32,765 | -4,733 | 0,280 | 265,317     |
|           | 0,400      | 1,092    | 23,784  | 16,967                  | 17,392         | 32,769 | -4,640 | 0,228 | 265,317     |
|           | 0,300      | 1,192    | 16,873  | 12,037                  | 12,338         | 32,778 | -4,487 | 0,175 | 245,811     |
|           | 0,200      | 1,292    | 10,237  | 7,303                   | 7,486          | 32,795 | -4,246 | 0,122 | 208,129     |
|           | 0,100      | 1,392    | 4,135   | 2,950                   | 3,023          | 32,856 | -3,783 | 0,067 | 141,185     |
|           | 0,039      | 1,454    | 1,000   | 0,713                   | 0,731          | 33,106 | -3,072 | 0,033 | 62,691      |
|           | 0,000      | 1,492    | 0,000   | 0,000                   | 0,000          | 35,864 | -0,778 | 0,008 | 0,000       |

**Tank Calibrations - WB 3 ER**

Fluid Type = Water Ballast      Specific gravity = 1,025  
 Permeability = 100 %  
 Trim = 0 m (+ve by stern); Heel = 0 deg to starboard

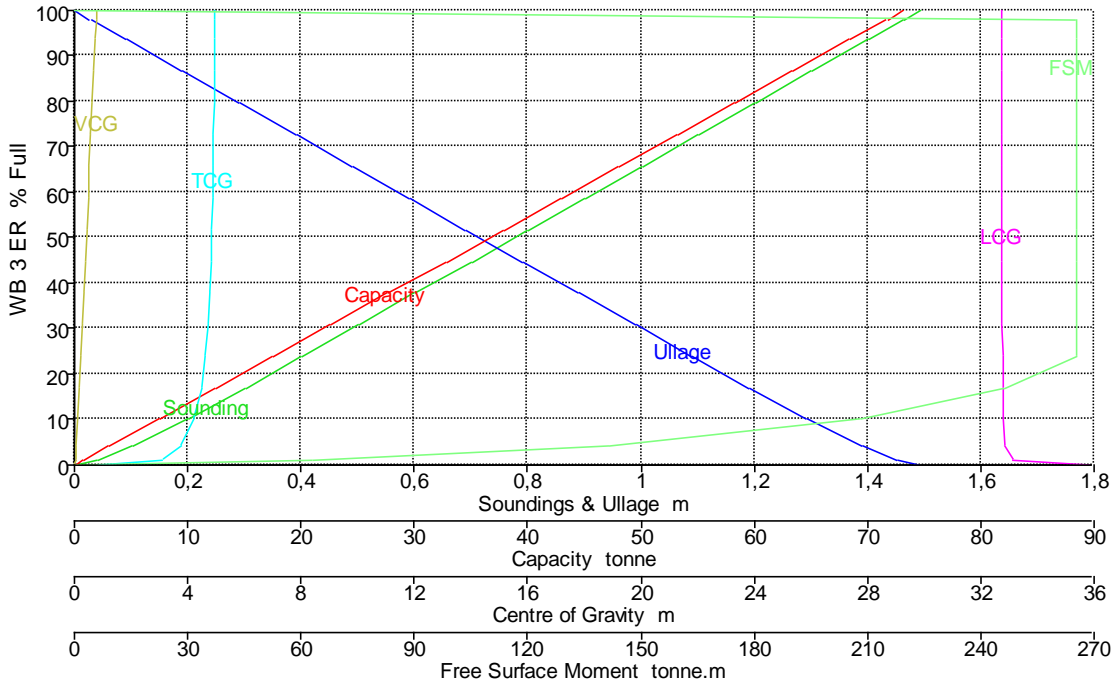

| Tank Name | Sounding m | Ullage m | % Full  | Capacity m <sup>3</sup> | Capacity tonne | LCG m  | TCG m | VCG m | FSM tonne.m |
|-----------|------------|----------|---------|-------------------------|----------------|--------|-------|-------|-------------|
| WB 3 ER   | 1,492      | 0,000    | 100,000 | 71,340                  | 73,123         | 32,755 | 4,952 | 0,781 | 0,000       |
|           | 1,464      | 0,029    | 98,000  | 69,913                  | 71,661         | 32,755 | 4,950 | 0,767 | 265,317     |
|           | 1,462      | 0,030    | 97,900  | 69,842                  | 71,588         | 32,755 | 4,950 | 0,766 | 265,317     |
|           | 1,400      | 0,092    | 93,549  | 66,737                  | 68,406         | 32,755 | 4,946 | 0,735 | 265,317     |
|           | 1,300      | 0,192    | 86,572  | 61,760                  | 63,304         | 32,755 | 4,937 | 0,685 | 265,317     |
|           | 1,200      | 0,292    | 79,596  | 56,783                  | 58,203         | 32,756 | 4,927 | 0,634 | 265,317     |
|           | 1,100      | 0,392    | 72,619  | 51,806                  | 53,102         | 32,756 | 4,916 | 0,584 | 265,317     |
|           | 1,000      | 0,492    | 65,643  | 46,829                  | 48,000         | 32,757 | 4,901 | 0,534 | 265,317     |
|           | 0,900      | 0,592    | 58,666  | 41,852                  | 42,899         | 32,758 | 4,884 | 0,484 | 265,317     |
|           | 0,800      | 0,692    | 51,690  | 36,875                  | 37,797         | 32,759 | 4,861 | 0,433 | 265,317     |
|           | 0,700      | 0,792    | 44,713  | 31,898                  | 32,696         | 32,760 | 4,832 | 0,382 | 265,317     |
|           | 0,600      | 0,892    | 37,737  | 26,921                  | 27,595         | 32,762 | 4,791 | 0,332 | 265,317     |
|           | 0,500      | 0,992    | 30,760  | 21,944                  | 22,493         | 32,765 | 4,733 | 0,280 | 265,317     |
|           | 0,400      | 1,092    | 23,784  | 16,967                  | 17,392         | 32,769 | 4,640 | 0,228 | 265,317     |
|           | 0,300      | 1,192    | 16,873  | 12,037                  | 12,338         | 32,778 | 4,487 | 0,175 | 245,811     |
|           | 0,200      | 1,292    | 10,237  | 7,303                   | 7,486          | 32,795 | 4,246 | 0,122 | 208,129     |
|           | 0,100      | 1,392    | 4,135   | 2,950                   | 3,023          | 32,856 | 3,783 | 0,067 | 141,185     |
|           | 0,039      | 1,454    | 1,000   | 0,713                   | 0,731          | 33,106 | 3,072 | 0,033 | 62,691      |
|           | 0,000      | 1,492    | 0,000   | 0,000                   | 0,000          | 35,864 | 0,778 | 0,008 | 0,000       |

**Tank Calibrations - WB 4 BR**

Fluid Type = Water Ballast      Specific gravity = 1,025  
 Permeability = 100 %  
 Trim = 0 m (+ve by stern); Heel = 0 deg to starboard

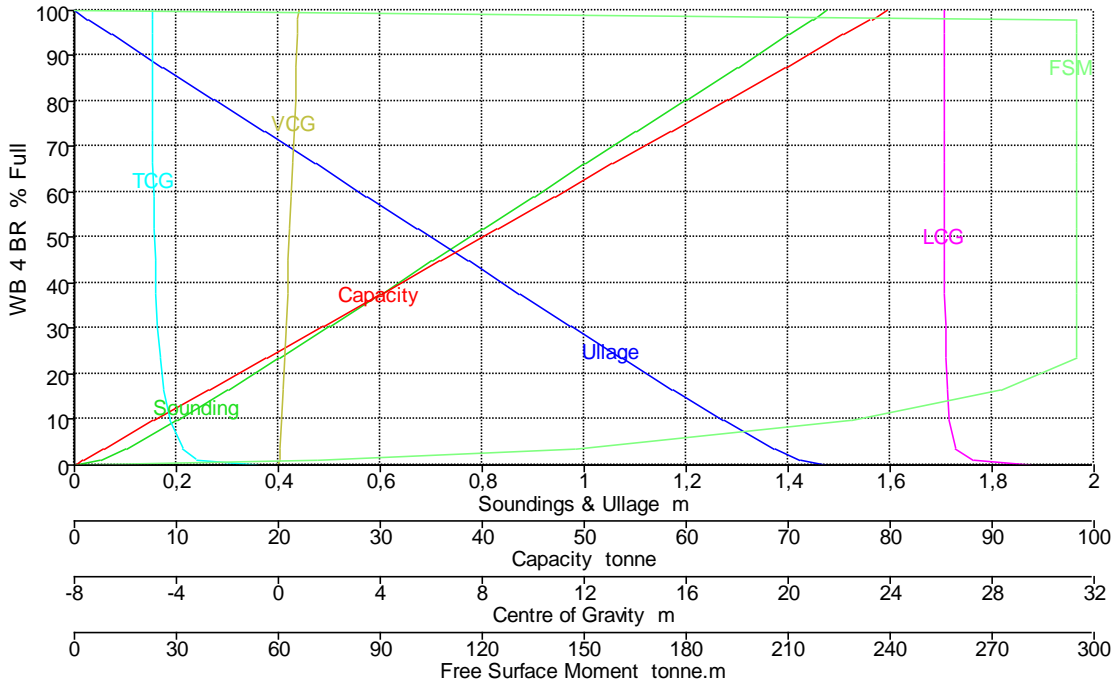

| Tank Name | Sounding m | Ullage m | % Full  | Capacity m <sup>3</sup> | Capacity tonne | LCG m  | TCG m  | VCG m | FSM tonne.m |
|-----------|------------|----------|---------|-------------------------|----------------|--------|--------|-------|-------------|
| WB 4 BR   | 1,475      | 0,000    | 100,000 | 77,719                  | 79,662         | 26,120 | -4,955 | 0,795 | 0,000       |
|           | 1,447      | 0,028    | 98,000  | 76,165                  | 78,069         | 26,120 | -4,953 | 0,781 | 294,796     |
|           | 1,446      | 0,030    | 97,900  | 76,087                  | 77,990         | 26,120 | -4,953 | 0,780 | 294,796     |
|           | 1,400      | 0,075    | 94,630  | 73,546                  | 75,384         | 26,121 | -4,950 | 0,757 | 294,796     |
|           | 1,300      | 0,175    | 87,514  | 68,016                  | 69,716         | 26,123 | -4,942 | 0,707 | 294,796     |
|           | 1,200      | 0,275    | 80,399  | 62,486                  | 64,048         | 26,125 | -4,932 | 0,657 | 294,796     |
|           | 1,100      | 0,375    | 73,284  | 56,956                  | 58,380         | 26,127 | -4,921 | 0,607 | 294,796     |
|           | 1,000      | 0,475    | 66,168  | 51,426                  | 52,711         | 26,130 | -4,907 | 0,557 | 294,796     |
|           | 0,900      | 0,575    | 59,053  | 45,896                  | 47,043         | 26,134 | -4,890 | 0,506 | 294,796     |
|           | 0,800      | 0,675    | 51,938  | 40,366                  | 41,375         | 26,139 | -4,868 | 0,456 | 294,796     |
|           | 0,700      | 0,775    | 44,822  | 34,836                  | 35,707         | 26,145 | -4,839 | 0,405 | 294,796     |
|           | 0,600      | 0,875    | 37,707  | 29,306                  | 30,038         | 26,153 | -4,799 | 0,354 | 294,796     |
|           | 0,500      | 0,975    | 30,592  | 23,776                  | 24,370         | 26,166 | -4,741 | 0,303 | 294,796     |
|           | 0,400      | 1,075    | 23,476  | 18,246                  | 18,702         | 26,185 | -4,647 | 0,251 | 294,725     |
|           | 0,300      | 1,175    | 16,431  | 12,770                  | 13,089         | 26,219 | -4,490 | 0,198 | 272,330     |
|           | 0,200      | 1,275    | 9,679   | 7,523                   | 7,711          | 26,292 | -4,240 | 0,144 | 228,260     |
|           | 0,100      | 1,375    | 3,521   | 2,736                   | 2,805          | 26,560 | -3,738 | 0,089 | 147,268     |
|           | 0,050      | 1,425    | 1,000   | 0,777                   | 0,797          | 27,298 | -3,195 | 0,061 | 71,059      |
|           | 0,000      | 1,475    | 0,000   | 0,000                   | 0,000          | 29,560 | -0,775 | 0,025 | 0,000       |

**Tank Calibrations - WB 4 ER**

Fluid Type = Water Ballast      Specific gravity = 1,025  
 Permeability = 100 %  
 Trim = 0 m (+ve by stern); Heel = 0 deg to starboard

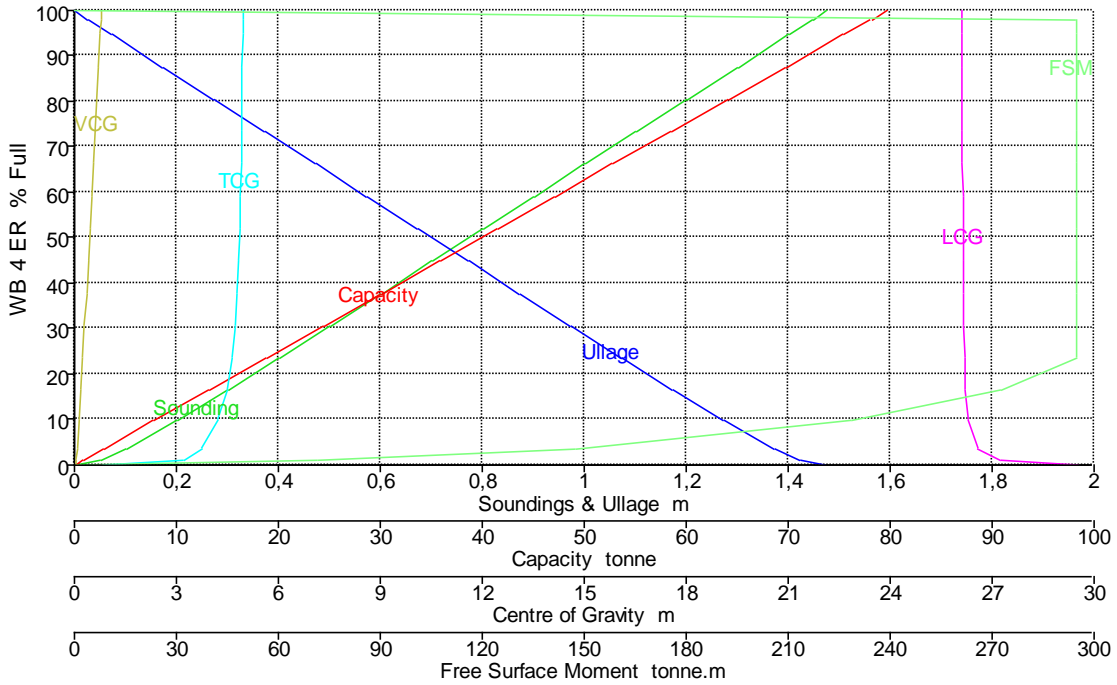

| Tank Name | Sounding m | Ullage m | % Full  | Capacity m <sup>3</sup> | Capacity tonne | LCG m  | TCG m | VCG m | FSM tonne.m |
|-----------|------------|----------|---------|-------------------------|----------------|--------|-------|-------|-------------|
| WB 4 ER   | 1,475      | 0,000    | 100,000 | 77,719                  | 79,662         | 26,120 | 4,955 | 0,795 | 0,000       |
|           | 1,447      | 0,028    | 98,000  | 76,165                  | 78,069         | 26,120 | 4,953 | 0,781 | 294,796     |
|           | 1,446      | 0,030    | 97,900  | 76,087                  | 77,990         | 26,120 | 4,953 | 0,780 | 294,796     |
|           | 1,400      | 0,075    | 94,630  | 73,546                  | 75,384         | 26,121 | 4,950 | 0,757 | 294,796     |
|           | 1,300      | 0,175    | 87,514  | 68,016                  | 69,716         | 26,123 | 4,942 | 0,707 | 294,796     |
|           | 1,200      | 0,275    | 80,399  | 62,486                  | 64,048         | 26,125 | 4,932 | 0,657 | 294,796     |
|           | 1,100      | 0,375    | 73,284  | 56,956                  | 58,380         | 26,127 | 4,921 | 0,607 | 294,796     |
|           | 1,000      | 0,475    | 66,168  | 51,426                  | 52,711         | 26,130 | 4,907 | 0,557 | 294,796     |
|           | 0,900      | 0,575    | 59,053  | 45,896                  | 47,043         | 26,134 | 4,890 | 0,506 | 294,796     |
|           | 0,800      | 0,675    | 51,938  | 40,366                  | 41,375         | 26,139 | 4,868 | 0,456 | 294,796     |
|           | 0,700      | 0,775    | 44,822  | 34,836                  | 35,707         | 26,145 | 4,839 | 0,405 | 294,796     |
|           | 0,600      | 0,875    | 37,707  | 29,306                  | 30,038         | 26,153 | 4,799 | 0,354 | 294,796     |
|           | 0,500      | 0,975    | 30,592  | 23,776                  | 24,370         | 26,166 | 4,741 | 0,303 | 294,796     |
|           | 0,400      | 1,075    | 23,476  | 18,246                  | 18,702         | 26,185 | 4,647 | 0,251 | 294,725     |
|           | 0,300      | 1,175    | 16,431  | 12,770                  | 13,089         | 26,219 | 4,490 | 0,198 | 272,330     |
|           | 0,200      | 1,275    | 9,679   | 7,523                   | 7,711          | 26,292 | 4,240 | 0,144 | 228,260     |
|           | 0,100      | 1,375    | 3,521   | 2,736                   | 2,805          | 26,560 | 3,738 | 0,089 | 147,268     |
|           | 0,050      | 1,425    | 1,000   | 0,777                   | 0,797          | 27,298 | 3,195 | 0,061 | 71,059      |
|           | 0,000      | 1,475    | 0,000   | 0,000                   | 0,000          | 29,560 | 0,775 | 0,025 | 0,000       |

### Tank Calibrations - WB 5 BR

Fluid Type = Water Ballast      Specific gravity = 1,025

Permeability = 100 %

Trim = 0 m (+ve by stern); Heel = 0 deg to starboard

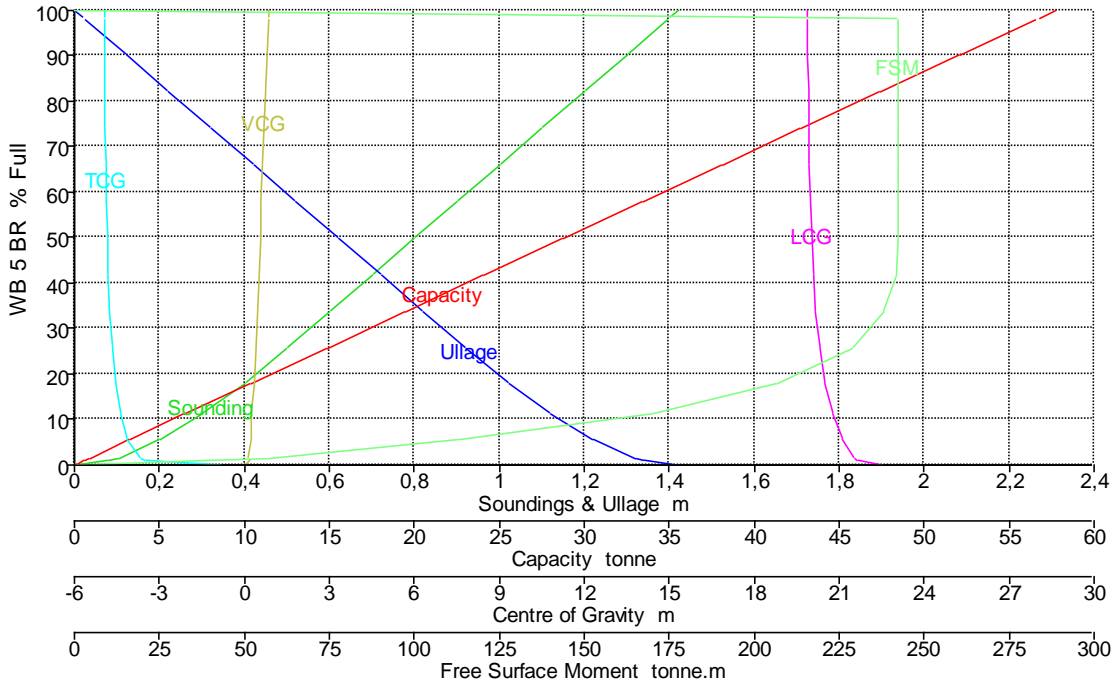

| Tank Name | Sounding m | Ullage m | % Full  | Capacity m <sup>3</sup> | Capacity tonne | LCG m  | TCG m  | VCG m | FSM tonne.m |
|-----------|------------|----------|---------|-------------------------|----------------|--------|--------|-------|-------------|
| WB 5 BR   | 1,422      | 0,000    | 100,000 | 56,331                  | 57,739         | 19,875 | -4,946 | 0,873 | 0,000       |
|           | 1,400      | 0,022    | 98,184  | 55,308                  | 56,691         | 19,878 | -4,944 | 0,862 | 242,575     |
|           | 1,398      | 0,025    | 98,000  | 55,205                  | 56,585         | 19,878 | -4,944 | 0,861 | 242,575     |
|           | 1,396      | 0,026    | 97,900  | 55,148                  | 56,527         | 19,878 | -4,944 | 0,860 | 242,575     |
|           | 1,300      | 0,122    | 90,106  | 50,758                  | 52,027         | 19,892 | -4,935 | 0,811 | 242,575     |
|           | 1,200      | 0,222    | 82,028  | 46,208                  | 47,363         | 19,909 | -4,923 | 0,760 | 242,575     |
|           | 1,100      | 0,322    | 73,950  | 41,657                  | 42,699         | 19,930 | -4,909 | 0,709 | 242,575     |
|           | 1,000      | 0,422    | 65,872  | 37,107                  | 38,034         | 19,955 | -4,892 | 0,658 | 242,575     |
|           | 0,900      | 0,522    | 57,795  | 32,556                  | 33,370         | 19,988 | -4,870 | 0,606 | 242,575     |
|           | 0,800      | 0,622    | 49,717  | 28,006                  | 28,706         | 20,032 | -4,841 | 0,554 | 242,575     |
|           | 0,700      | 0,722    | 41,642  | 23,457                  | 24,044         | 20,092 | -4,800 | 0,501 | 241,669     |
|           | 0,600      | 0,822    | 33,593  | 18,923                  | 19,396         | 20,179 | -4,743 | 0,446 | 237,898     |
|           | 0,500      | 0,922    | 25,625  | 14,435                  | 14,796         | 20,311 | -4,663 | 0,390 | 228,859     |
|           | 0,400      | 1,022    | 17,921  | 10,095                  | 10,348         | 20,519 | -4,550 | 0,334 | 206,172     |
|           | 0,300      | 1,122    | 11,080  | 6,242                   | 6,398          | 20,782 | -4,388 | 0,270 | 169,050     |
|           | 0,200      | 1,222    | 5,523   | 3,111                   | 3,189          | 21,097 | -4,122 | 0,243 | 113,158     |
|           | 0,100      | 1,322    | 1,527   | 0,860                   | 0,882          | 21,588 | -3,664 | 0,147 | 56,253      |
|           | 0,080      | 1,343    | 1,000   | 0,563                   | 0,577          | 21,693 | -3,478 | 0,206 | 39,910      |
|           | 0,000      | 1,422    | 0,000   | 0,000                   | 0,000          | 22,567 | -0,760 | 0,078 | 0,000       |

**Tank Calibrations - WB 5 ER**

Fluid Type = Water Ballast      Specific gravity = 1,025  
 Permeability = 100 %  
 Trim = 0 m (+ve by stern); Heel = 0 deg to starboard

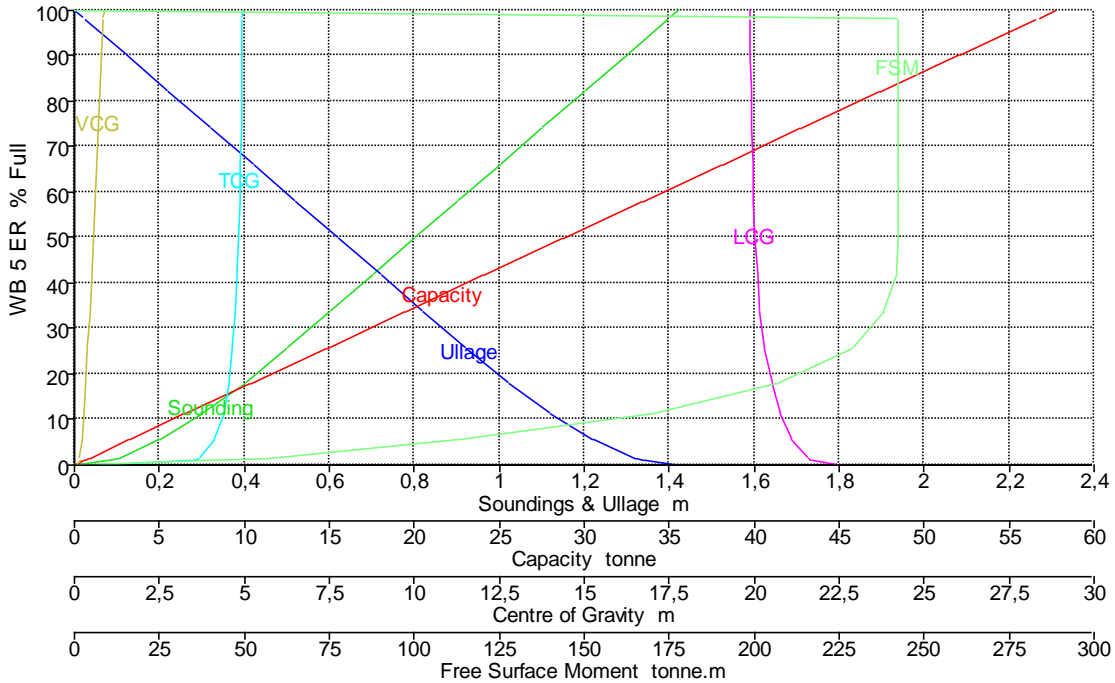

| Tank Name | Sounding m | Ullage m | % Full  | Capacity m <sup>3</sup> | Capacity tonne | LCG m  | TCG m | VCG m | FSM tonne.m |
|-----------|------------|----------|---------|-------------------------|----------------|--------|-------|-------|-------------|
| WB 5 ER   | 1,422      | 0,000    | 100,000 | 56,331                  | 57,739         | 19,875 | 4,946 | 0,873 | 0,000       |
|           | 1,400      | 0,022    | 98,184  | 55,308                  | 56,691         | 19,878 | 4,944 | 0,862 | 242,575     |
|           | 1,398      | 0,025    | 98,000  | 55,205                  | 56,585         | 19,878 | 4,944 | 0,861 | 242,575     |
|           | 1,396      | 0,026    | 97,900  | 55,148                  | 56,527         | 19,878 | 4,944 | 0,860 | 242,575     |
|           | 1,300      | 0,122    | 90,106  | 50,758                  | 52,027         | 19,892 | 4,935 | 0,811 | 242,575     |
|           | 1,200      | 0,222    | 82,028  | 46,208                  | 47,363         | 19,909 | 4,923 | 0,760 | 242,575     |
|           | 1,100      | 0,322    | 73,950  | 41,657                  | 42,699         | 19,930 | 4,909 | 0,709 | 242,575     |
|           | 1,000      | 0,422    | 65,872  | 37,107                  | 38,034         | 19,955 | 4,892 | 0,658 | 242,575     |
|           | 0,900      | 0,522    | 57,795  | 32,556                  | 33,370         | 19,988 | 4,870 | 0,606 | 242,575     |
|           | 0,800      | 0,622    | 49,717  | 28,006                  | 28,706         | 20,032 | 4,841 | 0,554 | 242,575     |
|           | 0,700      | 0,722    | 41,642  | 23,457                  | 24,044         | 20,092 | 4,800 | 0,501 | 241,669     |
|           | 0,600      | 0,822    | 33,593  | 18,923                  | 19,396         | 20,179 | 4,743 | 0,446 | 237,898     |
|           | 0,500      | 0,922    | 25,625  | 14,435                  | 14,796         | 20,311 | 4,663 | 0,390 | 228,859     |
|           | 0,400      | 1,022    | 17,921  | 10,095                  | 10,348         | 20,519 | 4,550 | 0,334 | 206,172     |
|           | 0,300      | 1,122    | 11,080  | 6,242                   | 6,398          | 20,782 | 4,388 | 0,270 | 169,050     |
|           | 0,200      | 1,222    | 5,523   | 3,111                   | 3,189          | 21,097 | 4,122 | 0,243 | 113,158     |
|           | 0,100      | 1,322    | 1,527   | 0,860                   | 0,882          | 21,588 | 3,664 | 0,147 | 56,253      |
|           | 0,080      | 1,343    | 1,000   | 0,563                   | 0,577          | 21,693 | 3,478 | 0,206 | 39,910      |
|           | 0,000      | 1,422    | 0,000   | 0,000                   | 0,000          | 22,567 | 0,760 | 0,078 | 0,000       |

**Tank Calibrations - WB 6 BR-ER**

Fluid Type = Water Ballast      Specific gravity = 1,025  
 Permeability = 100 %  
 Trim = 0 m (+ve by stern); Heel = 0 deg to starboard



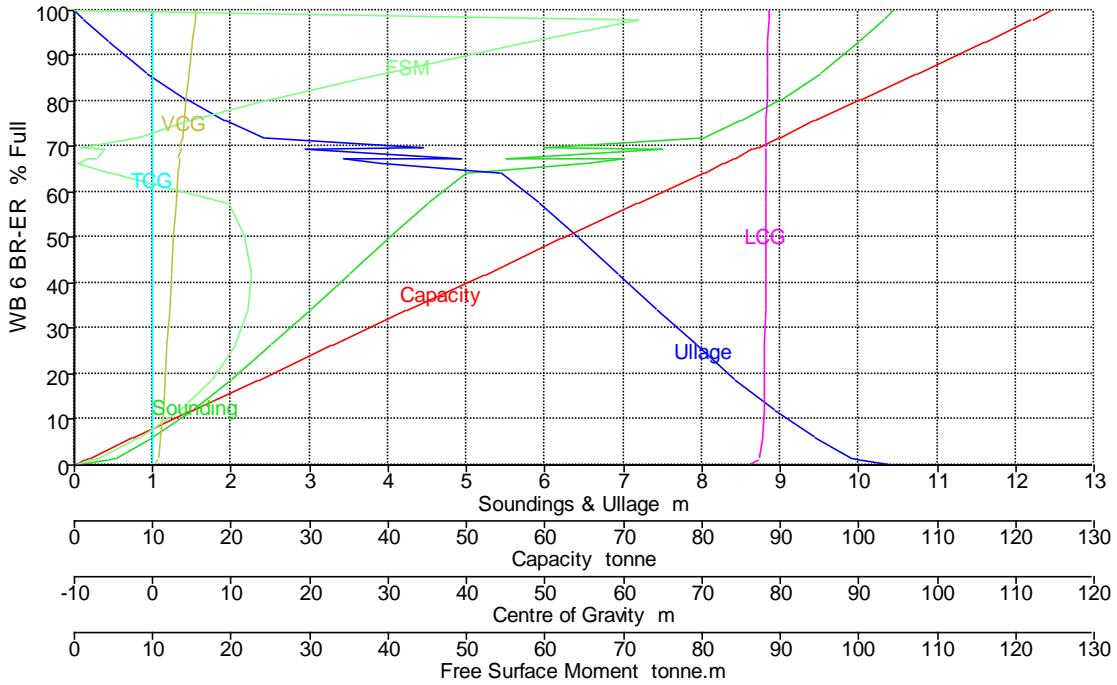

| Tank Name  | Sounding m | Ullage m | % Full  | Capacity m <sup>3</sup> | Capacity tonne | LCG m  | TCG m | VCG m | FSM tonne.m |
|------------|------------|----------|---------|-------------------------|----------------|--------|-------|-------|-------------|
| WB 6 BR-ER | 10,439     | 0,000    | 100,000 | 121,549                 | 124,588        | 78,517 | 0,000 | 5,459 | 0,000       |
|            | 10,317     | 0,122    | 98,000  | 119,118                 | 122,096        | 78,499 | 0,000 | 5,353 | 72,205      |
|            | 10,311     | 0,128    | 97,900  | 118,996                 | 121,971        | 78,498 | 0,000 | 5,347 | 71,904      |
|            | 10,000     | 0,439    | 93,064  | 113,119                 | 115,947        | 78,451 | 0,000 | 5,082 | 57,739      |
|            | 9,500      | 0,939    | 86,136  | 104,697                 | 107,314        | 78,378 | 0,000 | 4,684 | 38,941      |
|            | 9,000      | 1,439    | 80,308  | 97,614                  | 100,054        | 78,311 | 0,000 | 4,301 | 24,776      |
|            | 8,500      | 1,939    | 75,635  | 91,934                  | 94,232         | 78,257 | 0,000 | 3,965 | 14,708      |
|            | 8,000      | 2,439    | 72,023  | 87,543                  | 89,731         | 78,216 | 0,000 | 3,733 | 7,996       |
|            | 6,000      | 4,439    | 69,947  | 85,019                  | 87,145         | 78,242 | 0,000 | 3,360 | 0,750       |
|            | 7,500      | 2,939    | 69,353  | 84,298                  | 86,405         | 78,187 | 0,000 | 3,566 | 3,854       |
|            | 5,500      | 4,939    | 67,531  | 82,083                  | 84,135         | 78,199 | 0,000 | 3,264 | 2,825       |
|            | 7,000      | 3,439    | 67,481  | 82,022                  | 84,073         | 78,169 | 0,000 | 3,455 | 1,549       |
|            | 6,500      | 3,939    | 66,308  | 80,596                  | 82,611         | 78,160 | 0,000 | 3,390 | 0,468       |
|            | 5,000      | 5,439    | 64,320  | 78,180                  | 80,135         | 78,135 | 0,000 | 3,150 | 4,702       |
|            | 4,500      | 5,939    | 57,517  | 69,912                  | 71,660         | 78,119 | 0,000 | 2,925 | 19,752      |
|            | 4,000      | 6,439    | 49,808  | 60,541                  | 62,054         | 78,108 | 0,000 | 2,670 | 21,825      |
|            | 3,500      | 6,939    | 41,900  | 50,929                  | 52,202         | 78,090 | 0,000 | 2,407 | 22,647      |
|            | 3,000      | 7,439    | 33,967  | 41,286                  | 42,318         | 78,064 | 0,000 | 2,135 | 22,201      |
|            | 2,500      | 7,939    | 26,178  | 31,819                  | 32,614         | 78,025 | 0,000 | 1,857 | 20,476      |
|            | 2,000      | 8,439    | 18,724  | 22,759                  | 23,328         | 77,966 | 0,000 | 1,572 | 17,489      |
|            | 1,500      | 8,939    | 11,846  | 14,399                  | 14,758         | 77,869 | 0,000 | 1,281 | 13,334      |
|            | 1,000      | 9,439    | 5,890   | 7,160                   | 7,339          | 77,684 | 0,000 | 0,981 | 8,225       |
|            | 0,500      | 9,939    | 1,518   | 1,845                   | 1,891          | 77,250 | 0,000 | 0,667 | 2,761       |
|            | 0,412      | 10,027   | 1,000   | 1,215                   | 1,246          | 77,118 | 0,000 | 0,609 | 1,902       |
|            | 0,000      | 10,439   | 0,000   | 0,000                   | 0,000          | 75,812 | 0,000 | 0,321 | 0,000       |

### Tank Calibrations - WB 7 BR

Fluid Type = Water Ballast      Specific gravity = 1,025  
 Permeability = 100 %  
 Trim = 0 m (+ve by stern); Heel = 0 deg to starboard

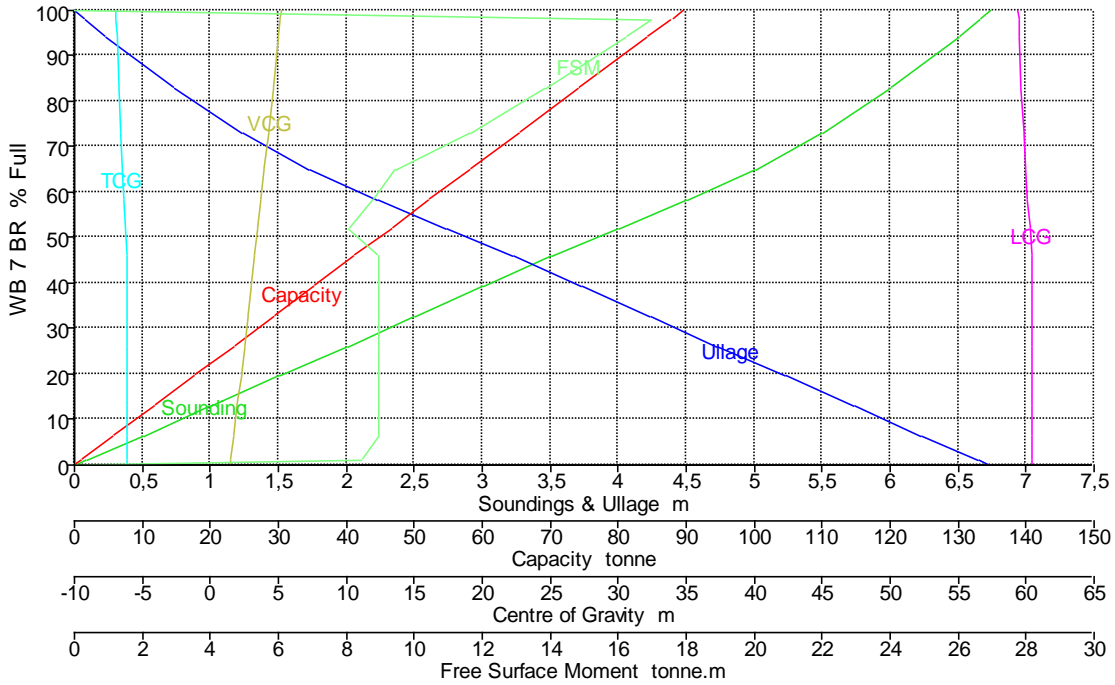

| Tank Name | Sounding m | Ullage m | % Full  | Capacity m <sup>3</sup> | Capacity tonne | LCG m  | TCG m  | VCG m | FSM tonne.m |
|-----------|------------|----------|---------|-------------------------|----------------|--------|--------|-------|-------------|
| WB 7 BR   | 6,740      | 0,000    | 100,000 | 87,390                  | 89,575         | 59,427 | -6,919 | 5,207 | 0,000       |
|           | 6,662      | 0,078    | 98,000  | 85,642                  | 87,783         | 59,447 | -6,900 | 5,146 | 16,990      |
|           | 6,658      | 0,082    | 97,900  | 85,555                  | 87,694         | 59,448 | -6,899 | 5,143 | 16,970      |
|           | 6,500      | 0,240    | 93,981  | 82,130                  | 84,183         | 59,488 | -6,858 | 5,020 | 16,195      |
|           | 6,000      | 0,740    | 82,635  | 72,214                  | 74,020         | 59,630 | -6,729 | 4,644 | 13,849      |
|           | 5,500      | 1,240    | 72,943  | 63,745                  | 65,339         | 59,787 | -6,601 | 4,297 | 11,622      |
|           | 5,000      | 1,740    | 64,953  | 56,763                  | 58,182         | 59,953 | -6,479 | 3,994 | 9,445       |
|           | 4,500      | 2,240    | 58,171  | 50,836                  | 52,106         | 60,135 | -6,358 | 3,731 | 8,746       |
|           | 4,000      | 2,740    | 52,011  | 45,453                  | 46,589         | 60,350 | -6,224 | 3,491 | 8,079       |
|           | 3,500      | 3,240    | 45,886  | 40,100                  | 41,102         | 60,476 | -6,149 | 3,258 | 8,958       |
|           | 3,000      | 3,740    | 39,300  | 34,344                  | 35,203         | 60,475 | -6,149 | 3,008 | 8,958       |
|           | 2,500      | 4,240    | 32,714  | 28,588                  | 29,303         | 60,474 | -6,148 | 2,757 | 8,958       |
|           | 2,000      | 4,740    | 26,127  | 22,833                  | 23,403         | 60,472 | -6,148 | 2,507 | 8,958       |
|           | 1,500      | 5,240    | 19,541  | 17,077                  | 17,504         | 60,469 | -6,147 | 2,257 | 8,958       |
|           | 1,000      | 5,740    | 12,955  | 11,321                  | 11,604         | 60,463 | -6,145 | 2,006 | 8,958       |
|           | 0,500      | 6,240    | 6,369   | 5,566                   | 5,705          | 60,445 | -6,140 | 1,754 | 8,942       |
|           | 0,083      | 6,657    | 1,000   | 0,874                   | 0,896          | 60,397 | -6,118 | 1,542 | 8,425       |
|           | 0,000      | 6,740    | 0,000   | 0,000                   | 0,000          | 60,384 | -6,112 | 1,500 | 0,000       |

**Tank Calibrations - WB 7 ER**

Fluid Type = Water Ballast      Specific gravity = 1,025  
 Permeability = 100 %  
 Trim = 0 m (+ve by stern); Heel = 0 deg to starboard

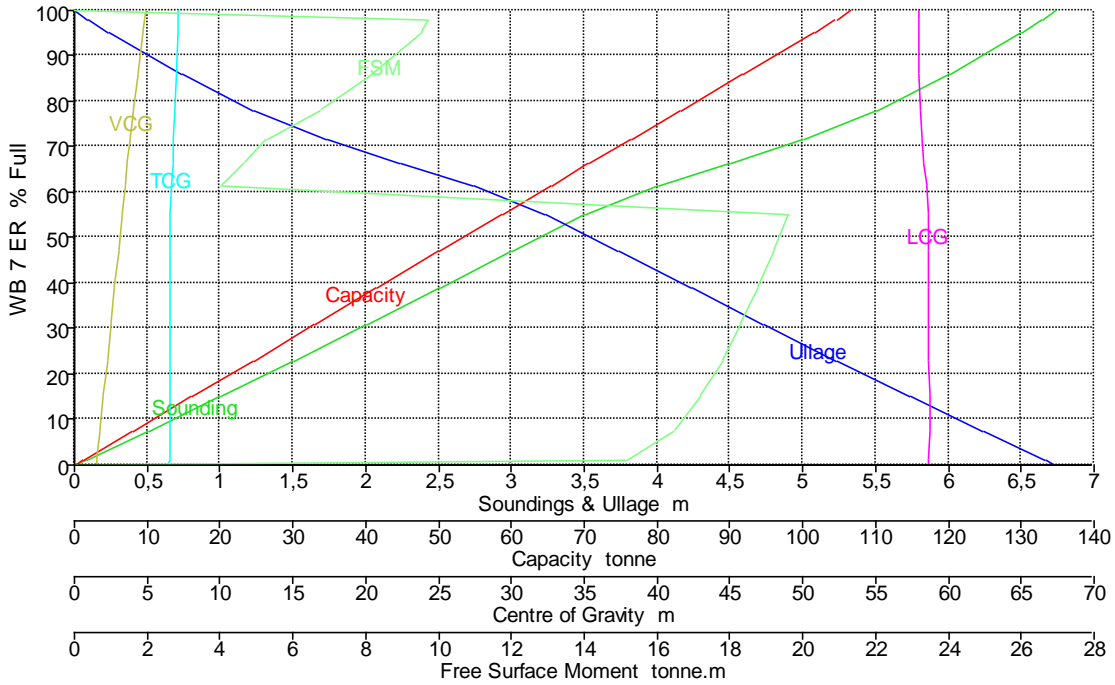

| Tank Name | Sounding m | Ullage m | % Full  | Capacity m <sup>3</sup> | Capacity tonne | LCG m  | TCG m | VCG m | FSM tonne.m |
|-----------|------------|----------|---------|-------------------------|----------------|--------|-------|-------|-------------|
| WB 7 ER   | 6,740      | 0,000    | 100,000 | 104,022                 | 106,623        | 57,914 | 7,160 | 4,870 | 0,000       |
|           | 6,642      | 0,098    | 98,000  | 101,942                 | 104,491        | 57,921 | 7,141 | 4,803 | 9,697       |
|           | 6,637      | 0,103    | 97,900  | 101,838                 | 104,384        | 57,922 | 7,141 | 4,799 | 9,693       |
|           | 6,500      | 0,240    | 95,157  | 98,985                  | 101,459        | 57,934 | 7,114 | 4,705 | 9,537       |
|           | 6,000      | 0,740    | 85,902  | 89,358                  | 91,592         | 57,996 | 7,016 | 4,376 | 8,178       |
|           | 5,500      | 1,240    | 78,030  | 81,169                  | 83,198         | 58,081 | 6,920 | 4,085 | 6,722       |
|           | 5,000      | 1,740    | 71,588  | 74,467                  | 76,329         | 58,192 | 6,831 | 3,845 | 5,237       |
|           | 4,500      | 2,240    | 66,160  | 68,821                  | 70,542         | 58,330 | 6,744 | 3,647 | 4,641       |
|           | 4,000      | 2,740    | 61,255  | 63,719                  | 65,312         | 58,498 | 6,651 | 3,478 | 4,004       |
|           | 3,500      | 3,240    | 54,979  | 57,191                  | 58,621         | 58,605 | 6,597 | 3,280 | 19,587      |
|           | 3,000      | 3,740    | 46,846  | 48,730                  | 49,948         | 58,621 | 6,588 | 3,025 | 19,193      |
|           | 2,500      | 4,240    | 38,781  | 40,341                  | 41,349         | 58,639 | 6,578 | 2,770 | 18,761      |
|           | 2,000      | 4,740    | 30,790  | 32,028                  | 32,829         | 58,658 | 6,567 | 2,516 | 18,297      |
|           | 1,500      | 5,240    | 22,881  | 23,801                  | 24,396         | 58,678 | 6,556 | 2,262 | 17,798      |
|           | 1,000      | 5,740    | 15,065  | 15,671                  | 16,062         | 58,698 | 6,542 | 2,008 | 17,211      |
|           | 0,500      | 6,240    | 7,364   | 7,660                   | 7,851          | 58,703 | 6,526 | 1,754 | 16,437      |
|           | 0,072      | 6,668    | 1,000   | 1,040                   | 1,066          | 58,640 | 6,508 | 1,536 | 15,136      |
|           | 0,000      | 6,740    | 0,000   | 0,000                   | 0,000          | 58,621 | 6,504 | 1,500 | 0,000       |

**Tank Calibrations - WB 8 BR**

Fluid Type = Water Ballast      Specific gravity = 1,025  
 Permeability = 100 %  
 Trim = 0 m (+ve by stern); Heel = 0 deg to starboard

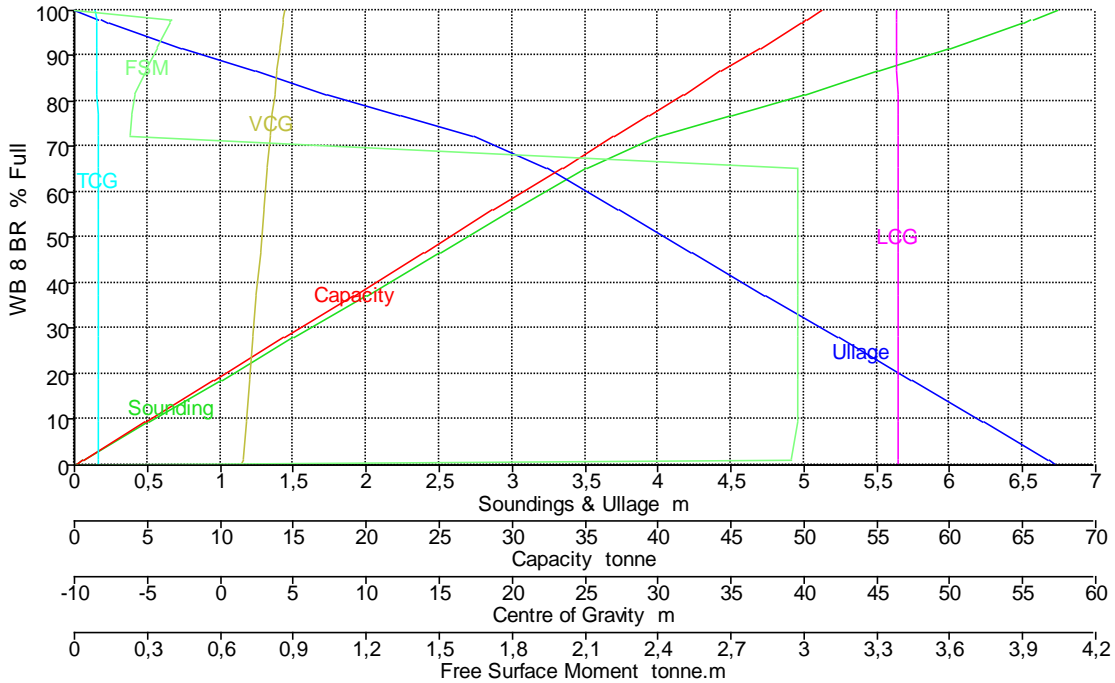

| Tank Name | Sounding m | Ullage m | % Full  | Capacity m <sup>3</sup> | Capacity tonne | LCG m  | TCG m  | VCG m | FSM tonne.m |
|-----------|------------|----------|---------|-------------------------|----------------|--------|--------|-------|-------------|
| WB 8 BR   | 6,740      | 0,000    | 100,000 | 49,944                  | 51,193         | 46,326 | -8,529 | 4,407 | 0,000       |
|           | 6,566      | 0,174    | 98,000  | 48,945                  | 50,169         | 46,333 | -8,518 | 4,331 | 0,398       |
|           | 6,557      | 0,183    | 97,900  | 48,896                  | 50,118         | 46,334 | -8,518 | 4,327 | 0,397       |
|           | 6,500      | 0,240    | 97,256  | 48,574                  | 49,788         | 46,336 | -8,515 | 4,302 | 0,391       |
|           | 6,000      | 0,740    | 91,735  | 45,817                  | 46,962         | 46,358 | -8,485 | 4,095 | 0,341       |
|           | 5,500      | 1,240    | 86,500  | 43,202                  | 44,282         | 46,384 | -8,454 | 3,904 | 0,293       |
|           | 5,000      | 1,740    | 81,573  | 40,741                  | 41,760         | 46,415 | -8,424 | 3,732 | 0,248       |
|           | 4,500      | 2,240    | 76,849  | 38,382                  | 39,341         | 46,449 | -8,391 | 3,577 | 0,238       |
|           | 4,000      | 2,740    | 72,196  | 36,058                  | 36,959         | 46,489 | -8,356 | 3,437 | 0,229       |
|           | 3,500      | 3,240    | 65,325  | 32,626                  | 33,442         | 46,511 | -8,336 | 3,250 | 2,976       |
|           | 3,000      | 3,740    | 55,990  | 27,964                  | 28,663         | 46,511 | -8,336 | 3,000 | 2,976       |
|           | 2,500      | 4,240    | 46,656  | 23,302                  | 23,885         | 46,511 | -8,336 | 2,750 | 2,976       |
|           | 2,000      | 4,740    | 37,322  | 18,640                  | 19,106         | 46,511 | -8,336 | 2,500 | 2,976       |
|           | 1,500      | 5,240    | 27,987  | 13,978                  | 14,328         | 46,511 | -8,335 | 2,250 | 2,976       |
|           | 1,000      | 5,740    | 18,653  | 9,316                   | 9,549          | 46,511 | -8,335 | 2,000 | 2,976       |
|           | 0,500      | 6,240    | 9,319   | 4,654                   | 4,770          | 46,512 | -8,335 | 1,750 | 2,976       |
|           | 0,054      | 6,686    | 1,000   | 0,499                   | 0,512          | 46,511 | -8,331 | 1,527 | 2,945       |
|           | 0,000      | 6,740    | 0,000   | 0,000                   | 0,000          | 46,512 | -8,330 | 1,500 | 0,000       |

**Tank Calibrations - WB 8 ER**

Fluid Type = Water Ballast      Specific gravity = 1,025  
 Permeability = 100 %  
 Trim = 0 m (+ve by stern); Heel = 0 deg to starboard

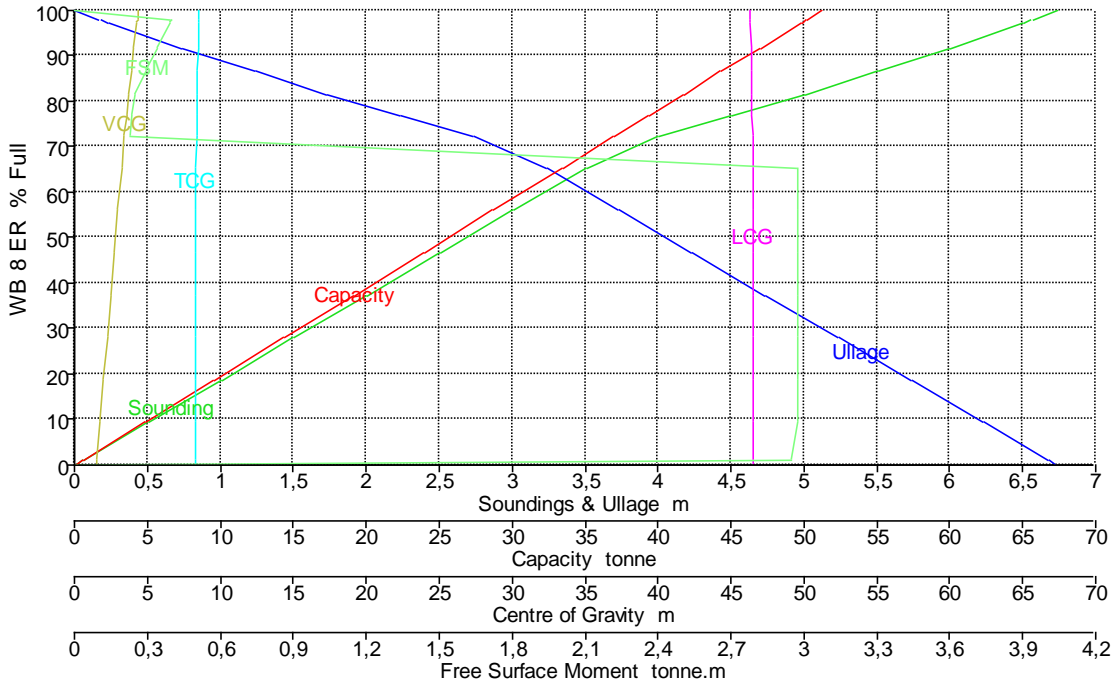

| Tank Name | Sounding m | Ullage m | % Full  | Capacity m <sup>3</sup> | Capacity tonne | LCG m  | TCG m | VCG m | FSM tonne.m |
|-----------|------------|----------|---------|-------------------------|----------------|--------|-------|-------|-------------|
| WB 8 ER   | 6,740      | 0,000    | 100,000 | 49,944                  | 51,193         | 46,326 | 8,529 | 4,407 | 0,000       |
|           | 6,566      | 0,174    | 98,000  | 48,945                  | 50,169         | 46,333 | 8,518 | 4,331 | 0,398       |
|           | 6,557      | 0,183    | 97,900  | 48,896                  | 50,118         | 46,334 | 8,518 | 4,327 | 0,397       |
|           | 6,500      | 0,240    | 97,256  | 48,574                  | 49,788         | 46,336 | 8,515 | 4,302 | 0,391       |
|           | 6,000      | 0,740    | 91,735  | 45,817                  | 46,962         | 46,358 | 8,485 | 4,095 | 0,341       |
|           | 5,500      | 1,240    | 86,500  | 43,202                  | 44,282         | 46,384 | 8,454 | 3,904 | 0,293       |
|           | 5,000      | 1,740    | 81,573  | 40,741                  | 41,760         | 46,415 | 8,424 | 3,732 | 0,248       |
|           | 4,500      | 2,240    | 76,849  | 38,382                  | 39,341         | 46,449 | 8,391 | 3,577 | 0,238       |
|           | 4,000      | 2,740    | 72,196  | 36,058                  | 36,959         | 46,489 | 8,356 | 3,437 | 0,229       |
|           | 3,500      | 3,240    | 65,325  | 32,626                  | 33,442         | 46,511 | 8,336 | 3,250 | 2,976       |
|           | 3,000      | 3,740    | 55,990  | 27,964                  | 28,663         | 46,511 | 8,336 | 3,000 | 2,976       |
|           | 2,500      | 4,240    | 46,656  | 23,302                  | 23,885         | 46,511 | 8,336 | 2,750 | 2,976       |
|           | 2,000      | 4,740    | 37,322  | 18,640                  | 19,106         | 46,511 | 8,336 | 2,500 | 2,976       |
|           | 1,500      | 5,240    | 27,987  | 13,978                  | 14,328         | 46,511 | 8,335 | 2,250 | 2,976       |
|           | 1,000      | 5,740    | 18,653  | 9,316                   | 9,549          | 46,511 | 8,335 | 2,000 | 2,976       |
|           | 0,500      | 6,240    | 9,319   | 4,654                   | 4,770          | 46,512 | 8,335 | 1,750 | 2,976       |
|           | 0,054      | 6,686    | 1,000   | 0,499                   | 0,512          | 46,511 | 8,331 | 1,527 | 2,945       |
|           | 0,000      | 6,740    | 0,000   | 0,000                   | 0,000          | 46,512 | 8,330 | 1,500 | 0,000       |

**Tank Calibrations - WB 9 BR**

Fluid Type = Water Ballast      Specific gravity = 1,025  
 Permeability = 100 %  
 Trim = 0 m (+ve by stern); Heel = 0 deg to starboard

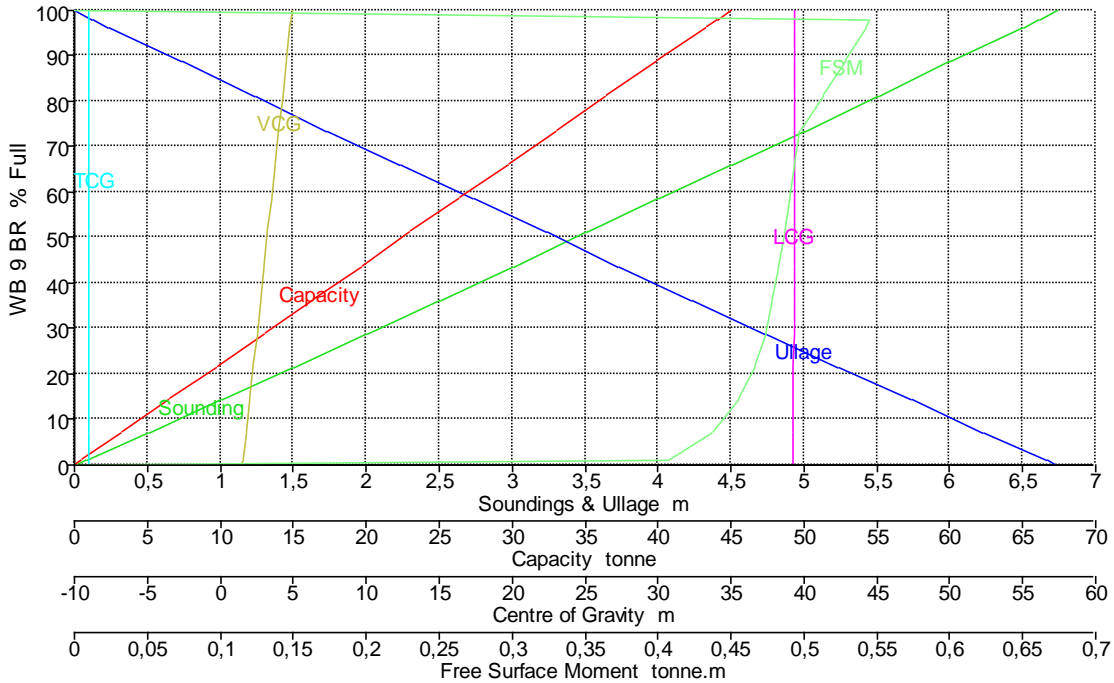

| Tank Name | Sounding m | Ullage m | % Full  | Capacity m <sup>3</sup> | Capacity tonne | LCG m  | TCG m  | VCG m | FSM tonne.m |
|-----------|------------|----------|---------|-------------------------|----------------|--------|--------|-------|-------------|
| WB 9 BR   | 6,740      | 0,000    | 100,000 | 43,861                  | 44,957         | 39,330 | -9,036 | 4,913 | 0,000       |
|           | 6,611      | 0,129    | 98,000  | 42,983                  | 44,058         | 39,329 | -9,035 | 4,846 | 0,545       |
|           | 6,604      | 0,136    | 97,900  | 42,940                  | 44,013         | 39,329 | -9,035 | 4,843 | 0,545       |
|           | 6,500      | 0,240    | 96,287  | 42,232                  | 43,288         | 39,328 | -9,035 | 4,789 | 0,542       |
|           | 6,000      | 0,740    | 88,598  | 38,860                  | 39,831         | 39,324 | -9,033 | 4,532 | 0,528       |
|           | 5,500      | 1,240    | 80,984  | 35,520                  | 36,408         | 39,321 | -9,032 | 4,276 | 0,513       |
|           | 5,000      | 1,740    | 73,454  | 32,217                  | 33,023         | 39,319 | -9,031 | 4,023 | 0,497       |
|           | 4,500      | 2,240    | 65,978  | 28,938                  | 29,662         | 39,317 | -9,030 | 3,770 | 0,493       |
|           | 4,000      | 2,740    | 58,521  | 25,668                  | 26,309         | 39,315 | -9,029 | 3,518 | 0,490       |
|           | 3,500      | 3,240    | 51,082  | 22,405                  | 22,965         | 39,313 | -9,028 | 3,266 | 0,487       |
|           | 3,000      | 3,740    | 43,663  | 19,151                  | 19,630         | 39,311 | -9,027 | 3,013 | 0,483       |
|           | 2,500      | 4,240    | 36,265  | 15,906                  | 16,304         | 39,308 | -9,026 | 2,761 | 0,479       |
|           | 2,000      | 4,740    | 28,892  | 12,672                  | 12,989         | 39,306 | -9,024 | 2,509 | 0,474       |
|           | 1,500      | 5,240    | 21,554  | 9,454                   | 9,690          | 39,303 | -9,021 | 2,256 | 0,467       |
|           | 1,000      | 5,740    | 14,264  | 6,256                   | 6,413          | 39,300 | -9,018 | 2,004 | 0,456       |
|           | 0,500      | 6,240    | 7,054   | 3,094                   | 3,171          | 39,295 | -9,013 | 1,751 | 0,437       |
|           | 0,072      | 6,668    | 1,000   | 0,439                   | 0,450          | 39,290 | -9,007 | 1,536 | 0,406       |
|           | 0,000      | 6,740    | 0,000   | 0,000                   | 0,000          | 39,289 | -9,005 | 1,500 | 0,000       |

**Tank Calibrations - WB 9 ER**

Fluid Type = Water Ballast      Specific gravity = 1,025  
 Permeability = 100 %  
 Trim = 0 m (+ve by stern); Heel = 0 deg to starboard

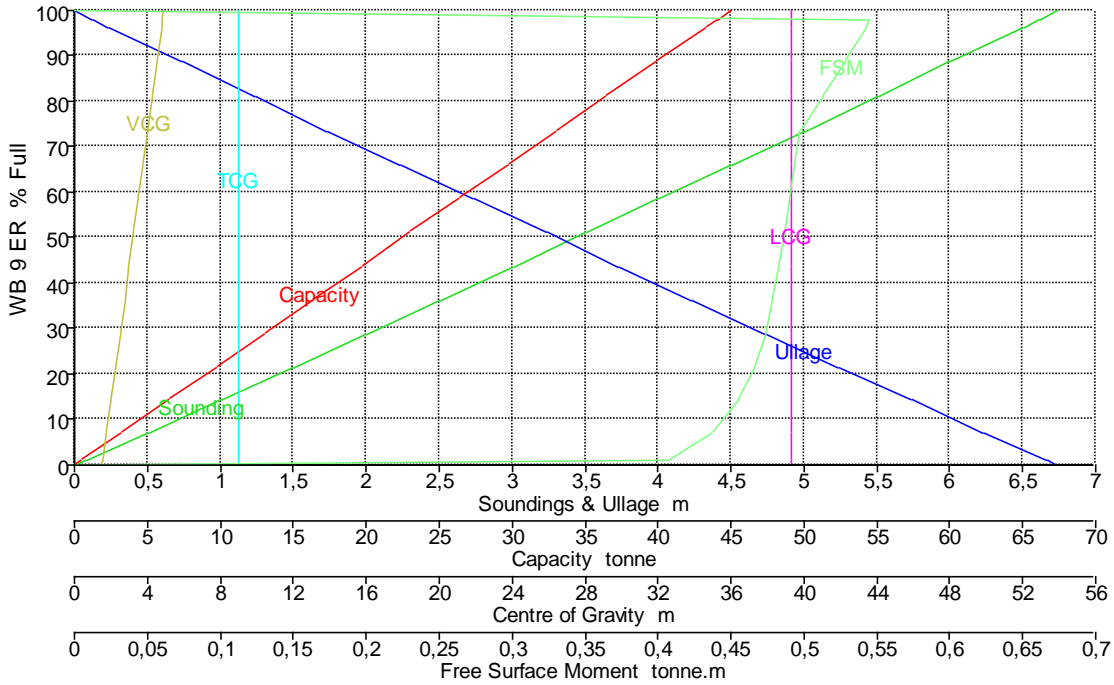

| Tank Name | Sounding m | Ullage m | % Full  | Capacity m <sup>3</sup> | Capacity tonne | LCG m  | TCG m | VCG m | FSM tonne.m |
|-----------|------------|----------|---------|-------------------------|----------------|--------|-------|-------|-------------|
| WB 9 ER   | 6,740      | 0,000    | 100,000 | 43,861                  | 44,957         | 39,330 | 9,036 | 4,913 | 0,000       |
|           | 6,611      | 0,129    | 98,000  | 42,983                  | 44,058         | 39,329 | 9,035 | 4,846 | 0,545       |
|           | 6,604      | 0,136    | 97,900  | 42,940                  | 44,013         | 39,329 | 9,035 | 4,843 | 0,545       |
|           | 6,500      | 0,240    | 96,287  | 42,232                  | 43,288         | 39,328 | 9,035 | 4,789 | 0,542       |
|           | 6,000      | 0,740    | 88,598  | 38,860                  | 39,831         | 39,324 | 9,033 | 4,532 | 0,528       |
|           | 5,500      | 1,240    | 80,984  | 35,520                  | 36,408         | 39,321 | 9,032 | 4,276 | 0,513       |
|           | 5,000      | 1,740    | 73,454  | 32,217                  | 33,023         | 39,319 | 9,031 | 4,023 | 0,497       |
|           | 4,500      | 2,240    | 65,978  | 28,938                  | 29,662         | 39,317 | 9,030 | 3,770 | 0,493       |
|           | 4,000      | 2,740    | 58,521  | 25,668                  | 26,309         | 39,315 | 9,029 | 3,518 | 0,490       |
|           | 3,500      | 3,240    | 51,082  | 22,405                  | 22,965         | 39,313 | 9,028 | 3,266 | 0,487       |
|           | 3,000      | 3,740    | 43,663  | 19,151                  | 19,630         | 39,311 | 9,027 | 3,013 | 0,483       |
|           | 2,500      | 4,240    | 36,265  | 15,906                  | 16,304         | 39,308 | 9,026 | 2,761 | 0,479       |
|           | 2,000      | 4,740    | 28,892  | 12,672                  | 12,989         | 39,306 | 9,024 | 2,509 | 0,474       |
|           | 1,500      | 5,240    | 21,554  | 9,454                   | 9,690          | 39,303 | 9,021 | 2,256 | 0,467       |
|           | 1,000      | 5,740    | 14,264  | 6,256                   | 6,413          | 39,300 | 9,018 | 2,004 | 0,456       |
|           | 0,500      | 6,240    | 7,054   | 3,094                   | 3,171          | 39,295 | 9,013 | 1,751 | 0,437       |
|           | 0,072      | 6,668    | 1,000   | 0,439                   | 0,450          | 39,290 | 9,007 | 1,536 | 0,406       |
|           | 0,000      | 6,740    | 0,000   | 0,000                   | 0,000          | 39,289 | 9,005 | 1,500 | 0,000       |

**Tank Calibrations - WB 10 BR**

Fluid Type = Water Ballast      Specific gravity = 1,025  
 Permeability = 100 %  
 Trim = 0 m (+ve by stern); Heel = 0 deg to starboard

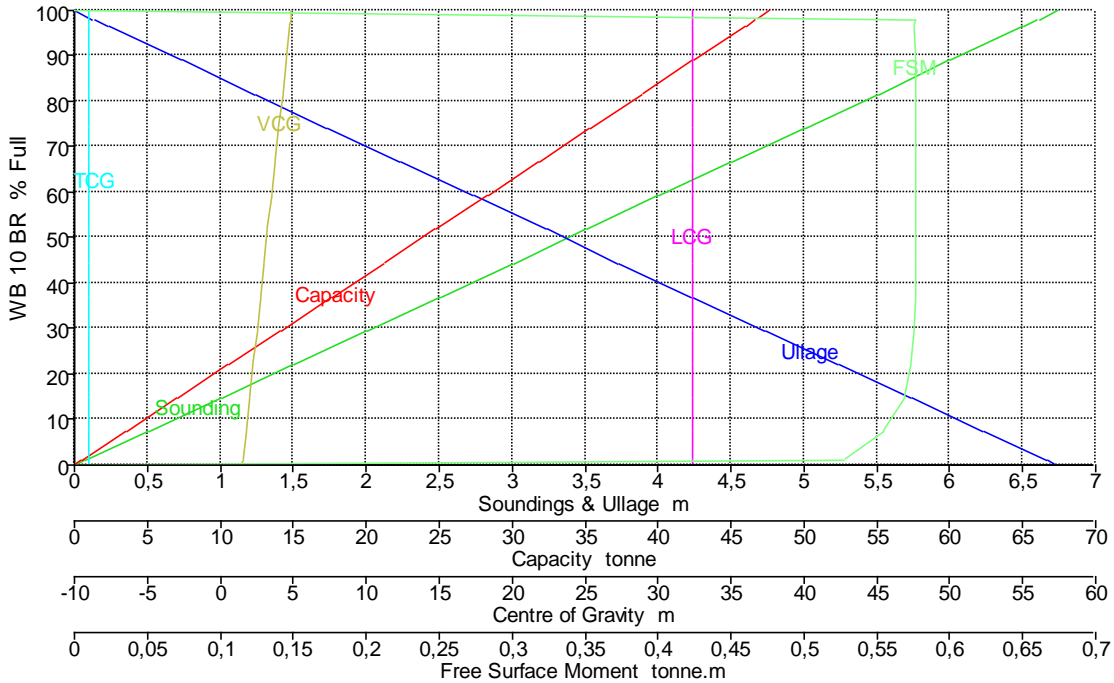

| Tank Name | Sounding m | Ullage m | % Full  | Capacity m <sup>3</sup> | Capacity tonne | LCG m  | TCG m  | VCG m | FSM tonne.m |
|-----------|------------|----------|---------|-------------------------|----------------|--------|--------|-------|-------------|
| WB 10 BR  | 6,740      | 0,000    | 100,000 | 46,492                  | 47,655         | 32,393 | -9,063 | 4,877 | 0,000       |
|           | 6,606      | 0,134    | 98,000  | 45,562                  | 46,701         | 32,393 | -9,063 | 4,810 | 0,576       |
|           | 6,599      | 0,141    | 97,900  | 45,516                  | 46,654         | 32,393 | -9,063 | 4,807 | 0,576       |
|           | 6,500      | 0,240    | 96,431  | 44,833                  | 45,954         | 32,393 | -9,063 | 4,757 | 0,576       |
|           | 6,000      | 0,740    | 88,996  | 41,376                  | 42,410         | 32,392 | -9,063 | 4,507 | 0,576       |
|           | 5,500      | 1,240    | 81,558  | 37,918                  | 38,866         | 32,392 | -9,062 | 4,257 | 0,577       |
|           | 5,000      | 1,740    | 74,120  | 34,460                  | 35,322         | 32,392 | -9,062 | 4,007 | 0,577       |
|           | 4,500      | 2,240    | 66,681  | 31,002                  | 31,777         | 32,391 | -9,062 | 3,757 | 0,577       |
|           | 4,000      | 2,740    | 59,243  | 27,543                  | 28,232         | 32,391 | -9,062 | 3,506 | 0,577       |
|           | 3,500      | 3,240    | 51,805  | 24,085                  | 24,687         | 32,391 | -9,062 | 3,256 | 0,577       |
|           | 3,000      | 3,740    | 44,368  | 20,628                  | 21,143         | 32,390 | -9,061 | 3,006 | 0,576       |
|           | 2,500      | 4,240    | 36,932  | 17,170                  | 17,600         | 32,389 | -9,061 | 2,755 | 0,576       |
|           | 2,000      | 4,740    | 29,498  | 13,714                  | 14,057         | 32,388 | -9,060 | 2,505 | 0,575       |
|           | 1,500      | 5,240    | 22,070  | 10,261                  | 10,517         | 32,387 | -9,059 | 2,254 | 0,574       |
|           | 1,000      | 5,740    | 14,654  | 6,813                   | 6,983          | 32,386 | -9,057 | 2,002 | 0,569       |
|           | 0,500      | 6,240    | 7,277   | 3,383                   | 3,468          | 32,385 | -9,053 | 1,751 | 0,555       |
|           | 0,069      | 6,671    | 1,000   | 0,465                   | 0,477          | 32,383 | -9,049 | 1,535 | 0,528       |
|           | 0,000      | 6,740    | 0,000   | 0,000                   | 0,000          | 32,383 | -9,047 | 1,500 | 0,000       |

**Tank Calibrations - WB 10 ER**

Fluid Type = Water Ballast      Specific gravity = 1,025  
 Permeability = 100 %  
 Trim = 0 m (+ve by stern); Heel = 0 deg to starboard



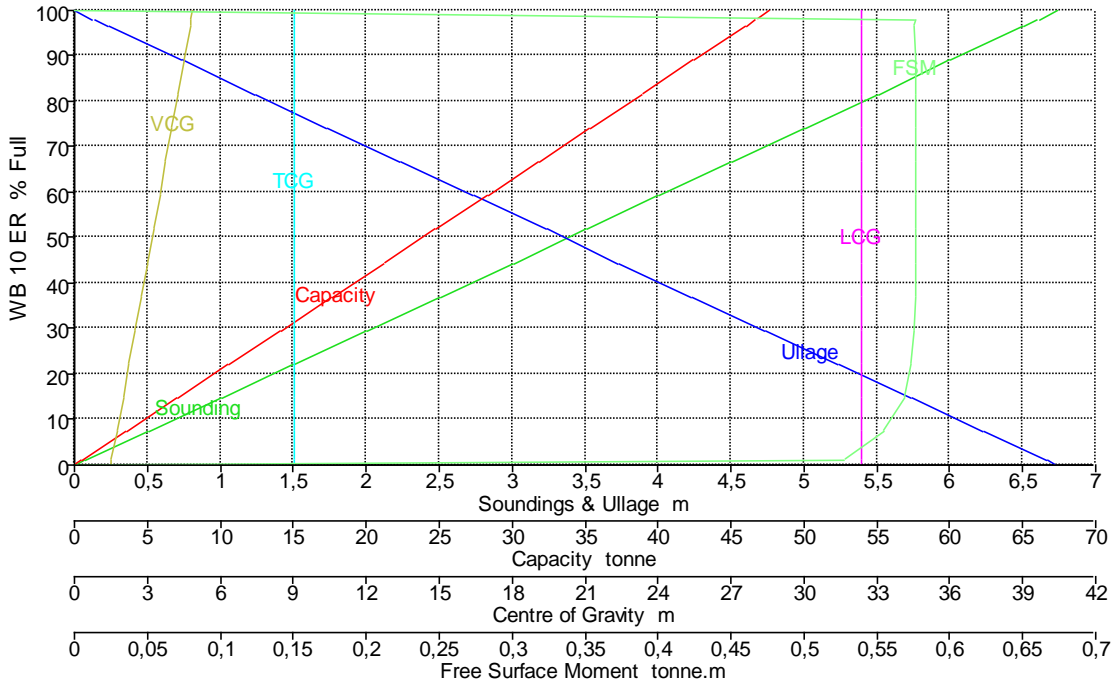

| Tank Name | Sounding m | Ullage m | % Full  | Capacity m <sup>3</sup> | Capacity tonne | LCG m  | TCG m | VCG m | FSM tonne.m |
|-----------|------------|----------|---------|-------------------------|----------------|--------|-------|-------|-------------|
| WB 10 ER  | 6,740      | 0,000    | 100,000 | 46,492                  | 47,655         | 32,393 | 9,063 | 4,877 | 0,000       |
|           | 6,606      | 0,134    | 98,000  | 45,562                  | 46,701         | 32,393 | 9,063 | 4,810 | 0,576       |
|           | 6,599      | 0,141    | 97,900  | 45,516                  | 46,654         | 32,393 | 9,063 | 4,807 | 0,576       |
|           | 6,500      | 0,240    | 96,431  | 44,833                  | 45,954         | 32,393 | 9,063 | 4,757 | 0,576       |
|           | 6,000      | 0,740    | 88,996  | 41,376                  | 42,410         | 32,392 | 9,063 | 4,507 | 0,576       |
|           | 5,500      | 1,240    | 81,558  | 37,918                  | 38,866         | 32,392 | 9,062 | 4,257 | 0,577       |
|           | 5,000      | 1,740    | 74,120  | 34,460                  | 35,322         | 32,392 | 9,062 | 4,007 | 0,577       |
|           | 4,500      | 2,240    | 66,681  | 31,002                  | 31,777         | 32,391 | 9,062 | 3,757 | 0,577       |
|           | 4,000      | 2,740    | 59,243  | 27,543                  | 28,232         | 32,391 | 9,062 | 3,506 | 0,577       |
|           | 3,500      | 3,240    | 51,805  | 24,085                  | 24,687         | 32,391 | 9,062 | 3,256 | 0,577       |
|           | 3,000      | 3,740    | 44,368  | 20,628                  | 21,143         | 32,390 | 9,061 | 3,006 | 0,576       |
|           | 2,500      | 4,240    | 36,932  | 17,170                  | 17,600         | 32,389 | 9,061 | 2,755 | 0,576       |
|           | 2,000      | 4,740    | 29,498  | 13,714                  | 14,057         | 32,388 | 9,060 | 2,505 | 0,575       |
|           | 1,500      | 5,240    | 22,070  | 10,261                  | 10,517         | 32,387 | 9,059 | 2,254 | 0,574       |
|           | 1,000      | 5,740    | 14,654  | 6,813                   | 6,983          | 32,386 | 9,057 | 2,002 | 0,569       |
|           | 0,500      | 6,240    | 7,277   | 3,383                   | 3,468          | 32,385 | 9,053 | 1,751 | 0,555       |
|           | 0,069      | 6,671    | 1,000   | 0,465                   | 0,477          | 32,383 | 9,049 | 1,535 | 0,528       |
|           | 0,000      | 6,740    | 0,000   | 0,000                   | 0,000          | 32,383 | 9,047 | 1,500 | 0,000       |

**Tank Calibrations - WB 11 BR-ER**

Fluid Type = Water Ballast      Specific gravity = 1,025  
 Permeability = 100 %  
 Trim = 0 m (+ve by stern); Heel = 0 deg to starboard

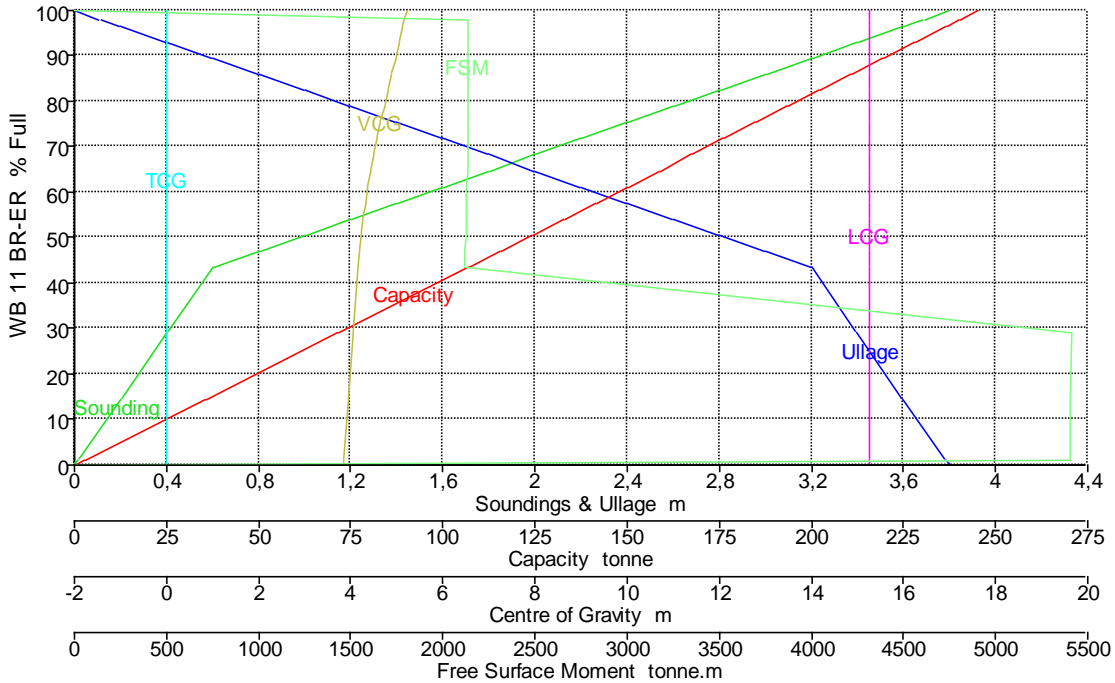

| Tank Name   | Sounding m | Ullage m | % Full  | Capacity m <sup>3</sup> | Capacity tonne | LCG m  | TCG m | VCG m | FSM tonne.m |
|-------------|------------|----------|---------|-------------------------|----------------|--------|-------|-------|-------------|
| WB 11 BR-ER | 3,800      | 0,000    | 100,000 | 239,112                 | 245,090        | 15,252 | 0,000 | 5,222 | 0,000       |
|             | 3,687      | 0,113    | 98,000  | 234,330                 | 240,188        | 15,252 | 0,000 | 5,174 | 2132,866    |
|             | 3,681      | 0,119    | 97,900  | 234,091                 | 239,943        | 15,252 | 0,000 | 5,171 | 2132,866    |
|             | 3,600      | 0,200    | 96,473  | 230,679                 | 236,446        | 15,252 | 0,000 | 5,137 | 2132,866    |
|             | 3,400      | 0,400    | 92,946  | 222,245                 | 227,801        | 15,252 | 0,000 | 5,053 | 2132,866    |
|             | 3,200      | 0,600    | 89,419  | 213,811                 | 219,157        | 15,252 | 0,000 | 4,970 | 2132,866    |
|             | 3,000      | 0,800    | 85,892  | 205,378                 | 210,512        | 15,253 | 0,000 | 4,889 | 2132,866    |
|             | 2,800      | 1,000    | 82,365  | 196,944                 | 201,868        | 15,253 | 0,000 | 4,809 | 2132,866    |
|             | 2,600      | 1,200    | 78,838  | 188,511                 | 193,223        | 15,253 | 0,000 | 4,731 | 2132,866    |
|             | 2,400      | 1,400    | 75,311  | 180,077                 | 184,579        | 15,253 | 0,000 | 4,656 | 2132,866    |
|             | 2,200      | 1,600    | 71,784  | 171,643                 | 175,935        | 15,253 | 0,000 | 4,582 | 2132,866    |
|             | 2,000      | 1,800    | 68,257  | 163,210                 | 167,290        | 15,253 | 0,000 | 4,511 | 2132,857    |
|             | 1,800      | 2,000    | 64,730  | 154,777                 | 158,646        | 15,253 | 0,000 | 4,444 | 2132,395    |
|             | 1,600      | 2,200    | 61,204  | 146,345                 | 150,004        | 15,253 | 0,000 | 4,380 | 2131,373    |
|             | 1,400      | 2,400    | 57,678  | 137,916                 | 141,364        | 15,254 | 0,000 | 4,321 | 2129,807    |
|             | 1,200      | 2,600    | 54,155  | 129,491                 | 132,729        | 15,254 | 0,000 | 4,267 | 2127,763    |
|             | 1,000      | 2,800    | 50,634  | 121,071                 | 124,098        | 15,254 | 0,000 | 4,220 | 2125,167    |
|             | 0,800      | 3,000    | 47,115  | 112,657                 | 115,474        | 15,253 | 0,000 | 4,180 | 2121,983    |
|             | 0,600      | 3,200    | 43,599  | 104,251                 | 106,857        | 15,253 | 0,000 | 4,150 | 2118,131    |
|             | 0,400      | 3,400    | 29,061  | 69,489                  | 71,226         | 15,253 | 0,000 | 4,050 | 5413,717    |
|             | 0,200      | 3,600    | 14,528  | 34,738                  | 35,606         | 15,254 | 0,000 | 3,950 | 5408,108    |
|             | 0,014      | 3,786    | 1,000   | 2,391                   | 2,451          | 15,254 | 0,000 | 3,857 | 5401,876    |
|             | 0,000      | 3,800    | 0,000   | 0,000                   | 0,000          | 15,254 | 0,000 | 3,850 | 0,000       |

**Tank Calibrations - WB 12 BR-ER**

Fluid Type = Water Ballast      Specific gravity = 1,025  
 Permeability = 100 %  
 Trim = 0 m (+ve by stern); Heel = 0 deg to starboard

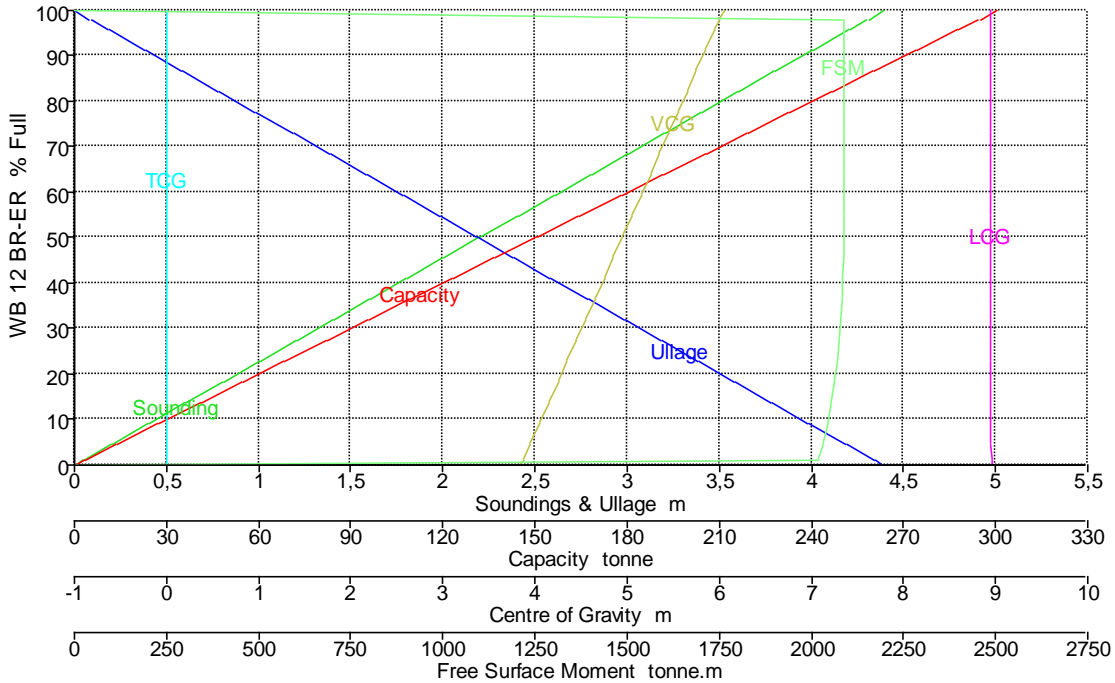

| Tank Name   | Sounding m | Ullage m | % Full  | Capacity m <sup>3</sup> | Capacity tonne | LCG m | TCG m | VCG m | FSM tonne.m |
|-------------|------------|----------|---------|-------------------------|----------------|-------|-------|-------|-------------|
| WB 12 BR-ER | 4,390      | 0,000    | 100,000 | 293,228                 | 300,559        | 8,951 | 0,000 | 6,048 | 0,000       |
|             | 4,302      | 0,088    | 98,000  | 287,364                 | 294,548        | 8,951 | 0,000 | 6,004 | 2089,654    |
|             | 4,298      | 0,092    | 97,900  | 287,070                 | 294,247        | 8,951 | 0,000 | 6,002 | 2089,654    |
|             | 4,200      | 0,190    | 95,664  | 280,513                 | 287,526        | 8,951 | 0,000 | 5,953 | 2089,654    |
|             | 4,000      | 0,390    | 91,099  | 267,129                 | 273,808        | 8,951 | 0,000 | 5,853 | 2089,654    |
|             | 3,800      | 0,590    | 86,535  | 253,745                 | 260,089        | 8,951 | 0,000 | 5,753 | 2089,654    |
|             | 3,600      | 0,790    | 81,971  | 240,361                 | 246,370        | 8,951 | 0,000 | 5,653 | 2089,654    |
|             | 3,400      | 0,990    | 77,406  | 226,977                 | 232,652        | 8,951 | 0,000 | 5,553 | 2089,654    |
|             | 3,200      | 1,190    | 72,842  | 213,593                 | 218,933        | 8,951 | 0,000 | 5,453 | 2089,654    |
|             | 3,000      | 1,390    | 68,278  | 200,209                 | 205,215        | 8,951 | 0,000 | 5,353 | 2089,654    |
|             | 2,800      | 1,590    | 63,713  | 186,825                 | 191,496        | 8,951 | 0,000 | 5,252 | 2089,654    |
|             | 2,600      | 1,790    | 59,149  | 173,441                 | 177,777        | 8,951 | 0,000 | 5,152 | 2089,654    |
|             | 2,400      | 1,990    | 54,585  | 160,057                 | 164,059        | 8,951 | 0,000 | 5,052 | 2089,654    |
|             | 2,200      | 2,190    | 50,020  | 146,674                 | 150,340        | 8,951 | 0,000 | 4,952 | 2089,227    |
|             | 2,000      | 2,390    | 45,457  | 133,292                 | 136,624        | 8,951 | 0,000 | 4,852 | 2087,651    |
|             | 1,800      | 2,590    | 40,895  | 119,915                 | 122,913        | 8,952 | 0,000 | 4,752 | 2085,371    |
|             | 1,600      | 2,790    | 36,334  | 106,543                 | 109,206        | 8,952 | 0,000 | 4,651 | 2082,517    |
|             | 1,400      | 2,990    | 31,776  | 93,178                  | 95,507         | 8,952 | 0,000 | 4,551 | 2079,032    |
|             | 1,200      | 3,190    | 27,221  | 79,821                  | 81,816         | 8,952 | 0,000 | 4,451 | 2074,727    |
|             | 1,000      | 3,390    | 22,670  | 66,474                  | 68,136         | 8,952 | 0,000 | 4,351 | 2069,490    |
|             | 0,800      | 3,590    | 18,122  | 53,140                  | 54,469         | 8,952 | 0,000 | 4,250 | 2063,085    |
|             | 0,600      | 3,790    | 13,580  | 39,821                  | 40,817         | 8,953 | 0,000 | 4,150 | 2055,202    |
|             | 0,400      | 3,990    | 9,045   | 26,521                  | 27,184         | 8,953 | 0,000 | 4,050 | 2045,420    |
|             | 0,200      | 4,190    | 4,517   | 13,245                  | 13,577         | 8,954 | 0,000 | 3,950 | 2033,122    |
|             | 0,044      | 4,346    | 1,000   | 2,932                   | 3,006          | 8,954 | 0,000 | 3,872 | 2021,099    |
|             | 0,000      | 4,390    | 0,000   | 0,000                   | 0,000          | 8,954 | 0,000 | 3,850 | 0,000       |

### Tank Calibrations - WB 13 BR-ER

Fluid Type = Water Ballast      Specific gravity = 1,025  
 Permeability = 100 %

Trim = 0 m (+ve by stern); Heel = 0 deg to starboard

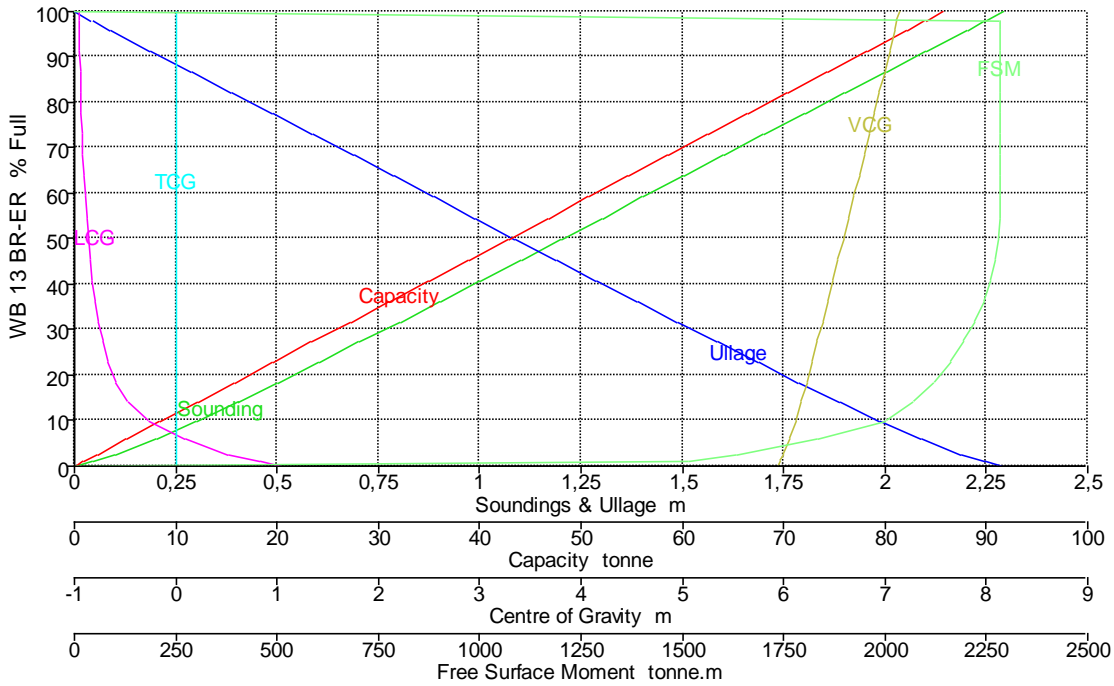

| Tank Name   | Sounding m | Ullage m | % Full  | Capacity m <sup>3</sup> | Capacity tonne | LCG m  | TCG m | VCG m | FSM tonne.m |
|-------------|------------|----------|---------|-------------------------|----------------|--------|-------|-------|-------------|
| WB 13 BR-ER | 2,290      | 0,000    | 100,000 | 83,536                  | 85,624         | -0,959 | 0,000 | 7,143 | 0,000       |
|             | 2,246      | 0,044    | 98,000  | 81,865                  | 83,912         | -0,957 | 0,000 | 7,121 | 2282,228    |
|             | 2,244      | 0,046    | 97,900  | 81,782                  | 83,826         | -0,957 | 0,000 | 7,120 | 2282,236    |
|             | 2,200      | 0,090    | 95,870  | 80,086                  | 82,088         | -0,955 | 0,000 | 7,097 | 2282,394    |
|             | 2,100      | 0,190    | 91,281  | 76,253                  | 78,159         | -0,950 | 0,000 | 7,047 | 2282,746    |
|             | 2,000      | 0,290    | 86,692  | 72,419                  | 74,229         | -0,945 | 0,000 | 6,997 | 2283,097    |
|             | 1,900      | 0,390    | 82,102  | 68,585                  | 70,299         | -0,939 | 0,000 | 6,946 | 2283,489    |
|             | 1,800      | 0,490    | 77,512  | 64,750                  | 66,369         | -0,932 | 0,000 | 6,896 | 2283,861    |
|             | 1,700      | 0,590    | 72,921  | 60,915                  | 62,438         | -0,925 | 0,000 | 6,845 | 2284,211    |
|             | 1,600      | 0,690    | 68,330  | 57,080                  | 58,507         | -0,916 | 0,000 | 6,795 | 2284,540    |
|             | 1,500      | 0,790    | 63,738  | 53,244                  | 54,575         | -0,906 | 0,000 | 6,744 | 2284,848    |
|             | 1,400      | 0,890    | 59,146  | 49,408                  | 50,643         | -0,895 | 0,000 | 6,693 | 2285,132    |
|             | 1,300      | 0,990    | 54,554  | 45,572                  | 46,711         | -0,882 | 0,000 | 6,642 | 2284,203    |
|             | 1,200      | 1,090    | 49,965  | 41,738                  | 42,782         | -0,866 | 0,000 | 6,591 | 2280,230    |
|             | 1,100      | 1,190    | 45,383  | 37,911                  | 38,859         | -0,848 | 0,000 | 6,539 | 2272,286    |
|             | 1,000      | 1,290    | 40,814  | 34,095                  | 34,947         | -0,826 | 0,000 | 6,488 | 2260,114    |
|             | 0,900      | 1,390    | 36,264  | 30,294                  | 31,051         | -0,799 | 0,000 | 6,436 | 2243,354    |
|             | 0,800      | 1,490    | 31,739  | 26,513                  | 27,176         | -0,765 | 0,000 | 6,384 | 2221,489    |
|             | 0,700      | 1,590    | 27,246  | 22,760                  | 23,329         | -0,723 | 0,000 | 6,332 | 2193,919    |
|             | 0,600      | 1,690    | 22,794  | 19,041                  | 19,517         | -0,666 | 0,000 | 6,279 | 2160,009    |
|             | 0,500      | 1,790    | 18,392  | 15,364                  | 15,748         | -0,587 | 0,000 | 6,226 | 2118,279    |
|             | 0,400      | 1,890    | 14,053  | 11,739                  | 12,033         | -0,465 | 0,000 | 6,172 | 2066,814    |
|             | 0,300      | 1,990    | 9,797   | 8,184                   | 8,389          | -0,254 | 0,000 | 6,116 | 1999,515    |
|             | 0,200      | 2,090    | 5,846   | 4,884                   | 5,006          | 0,097  | 0,000 | 6,057 | 1833,089    |
|             | 0,100      | 2,190    | 2,571   | 2,148                   | 2,201          | 0,529  | 0,000 | 5,999 | 1632,113    |
|             | 0,042      | 2,248    | 1,000   | 0,835                   | 0,856          | 0,838  | 0,000 | 5,967 | 1515,154    |
|             | 0,000      | 2,290    | 0,000   | 0,000                   | 0,000          | 1,050  | 0,000 | 5,950 | 0,000       |

Tank Calibrations - FW 1 BR

Fluid Type = Fresh Water    Specific gravity = 1  
 Permeability = 100 %  
 Trim = 0 m (+ve by stern); Heel = 0 deg to starboard

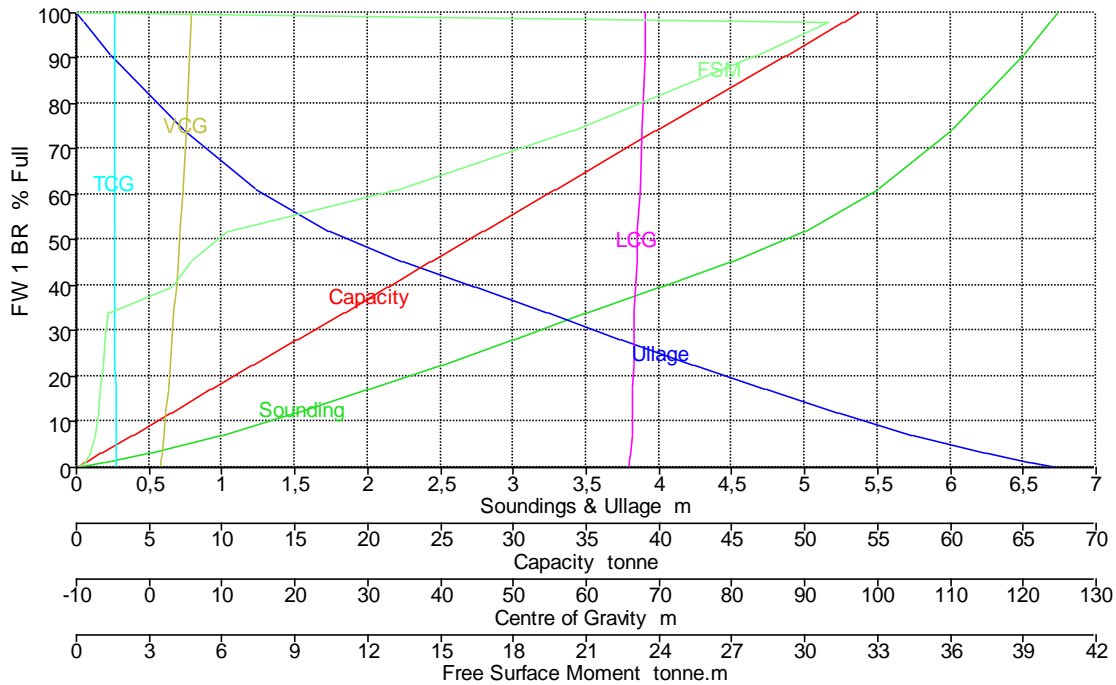

| Tank Name | Sounding m | Ullage m | % Full  | Capacity m <sup>3</sup> | Capacity tonne | LCG m  | TCG m  | VCG m | FSM tonne.m |
|-----------|------------|----------|---------|-------------------------|----------------|--------|--------|-------|-------------|
| FW 1 BR   | 6,740      | 0,000    | 100,000 | 53,737                  | 53,737         | 68,185 | -4,838 | 5,815 | 0,000       |
|           | 6,690      | 0,050    | 98,000  | 52,663                  | 52,663         | 68,154 | -4,833 | 5,766 | 30,994      |
|           | 6,688      | 0,052    | 97,900  | 52,609                  | 52,609         | 68,153 | -4,832 | 5,764 | 30,953      |
|           | 6,500      | 0,240    | 90,672  | 48,725                  | 48,725         | 68,032 | -4,815 | 5,578 | 27,971      |
|           | 6,000      | 0,740    | 73,964  | 39,746                  | 39,746         | 67,691 | -4,778 | 5,085 | 20,441      |
|           | 5,500      | 1,240    | 60,997  | 32,778                  | 32,778         | 67,356 | -4,753 | 4,621 | 13,161      |
|           | 5,000      | 1,740    | 51,817  | 27,845                  | 27,845         | 67,102 | -4,728 | 4,240 | 6,256       |
|           | 4,500      | 2,240    | 45,187  | 24,282                  | 24,282         | 66,919 | -4,701 | 3,945 | 4,756       |
|           | 4,000      | 2,740    | 39,712  | 21,340                  | 21,340         | 66,731 | -4,678 | 3,695 | 3,928       |
|           | 3,500      | 3,240    | 34,182  | 18,369                  | 18,369         | 66,599 | -4,665 | 3,445 | 1,284       |
|           | 3,000      | 3,740    | 28,134  | 15,119                  | 15,119         | 66,547 | -4,655 | 3,163 | 1,184       |
|           | 2,500      | 4,240    | 22,422  | 12,049                  | 12,049         | 66,492 | -4,644 | 2,885 | 1,099       |
|           | 2,000      | 4,740    | 17,018  | 9,145                   | 9,145          | 66,429 | -4,632 | 2,608 | 1,006       |
|           | 1,500      | 5,240    | 11,911  | 6,400                   | 6,400          | 66,347 | -4,617 | 2,330 | 0,927       |
|           | 1,000      | 5,740    | 7,191   | 3,864                   | 3,864          | 66,237 | -4,595 | 2,051 | 0,793       |
|           | 0,500      | 6,240    | 3,081   | 1,656                   | 1,656          | 66,089 | -4,557 | 1,771 | 0,588       |
|           | 0,187      | 6,553    | 1,000   | 0,537                   | 0,537          | 65,978 | -4,507 | 1,612 | 0,384       |
|           | 0,000      | 6,740    | 0,000   | 0,000                   | 0,000          | 65,892 | -4,496 | 1,500 | 0,000       |

### Tank Calibrations - FW 1 ER

Fluid Type = Fresh Water    Specific gravity = 1  
 Permeability = 100 %  
 Trim = 0 m (+ve by stern); Heel = 0 deg to starboard

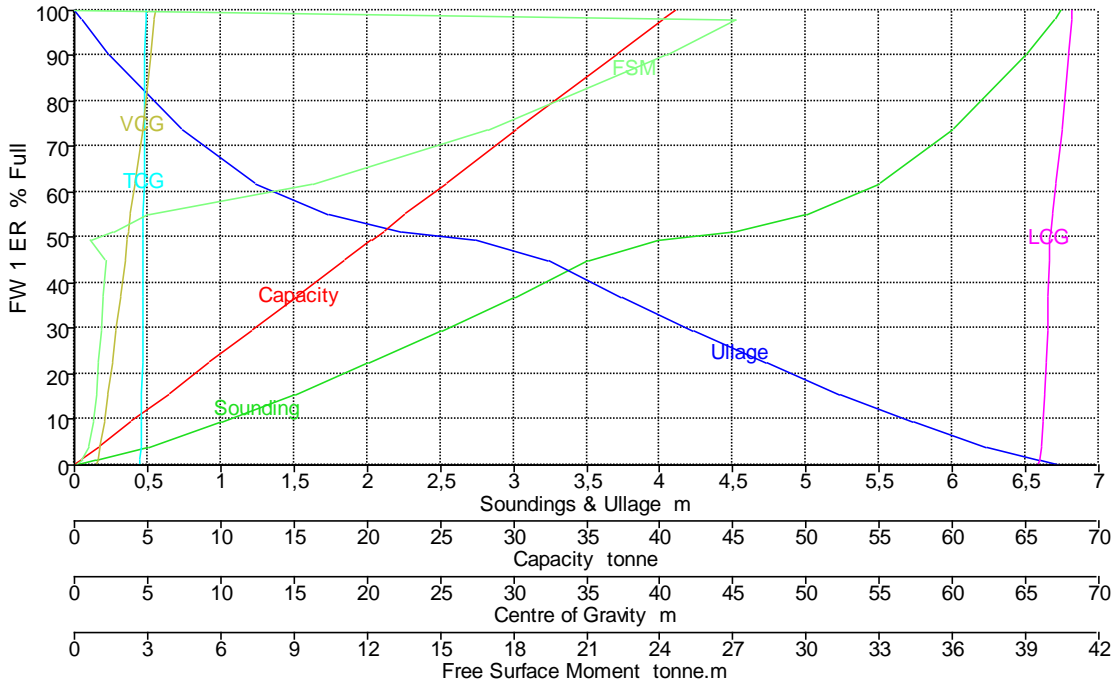

| Tank Name | Sounding m | Ullage m | % Full  | Capacity m <sup>3</sup> | Capacity tonne | LCG m  | TCG m | VCG m | FSM tonne.m |
|-----------|------------|----------|---------|-------------------------|----------------|--------|-------|-------|-------------|
| FW 1 ER   | 6,740      | 0,000    | 100,000 | 41,036                  | 41,036         | 68,150 | 4,863 | 5,527 | 0,000       |
|           | 6,693      | 0,047    | 98,000  | 40,215                  | 40,215         | 68,111 | 4,857 | 5,472 | 27,146      |
|           | 6,690      | 0,050    | 97,900  | 40,174                  | 40,174         | 68,109 | 4,857 | 5,469 | 27,110      |
|           | 6,500      | 0,240    | 90,274  | 37,045                  | 37,045         | 67,949 | 4,834 | 5,247 | 24,224      |
|           | 6,000      | 0,740    | 73,580  | 30,194                  | 30,194         | 67,503 | 4,785 | 4,677 | 16,932      |
|           | 5,500      | 1,240    | 61,786  | 25,355                  | 25,355         | 67,086 | 4,750 | 4,182 | 9,724       |
|           | 5,000      | 1,740    | 54,941  | 22,546                  | 22,546         | 66,831 | 4,719 | 3,858 | 2,999       |
|           | 4,500      | 2,240    | 51,361  | 21,077                  | 21,077         | 66,713 | 4,692 | 3,690 | 1,561       |
|           | 4,000      | 2,740    | 49,316  | 20,237                  | 20,237         | 66,645 | 4,674 | 3,603 | 0,663       |
|           | 3,500      | 3,240    | 44,762  | 18,369                  | 18,369         | 66,599 | 4,665 | 3,445 | 1,284       |
|           | 3,000      | 3,740    | 36,842  | 15,119                  | 15,119         | 66,547 | 4,655 | 3,163 | 1,184       |
|           | 2,500      | 4,240    | 29,362  | 12,049                  | 12,049         | 66,492 | 4,644 | 2,885 | 1,099       |
|           | 2,000      | 4,740    | 22,285  | 9,145                   | 9,145          | 66,429 | 4,632 | 2,608 | 1,006       |
|           | 1,500      | 5,240    | 15,597  | 6,400                   | 6,400          | 66,347 | 4,617 | 2,330 | 0,927       |
|           | 1,000      | 5,740    | 9,417   | 3,864                   | 3,864          | 66,237 | 4,595 | 2,051 | 0,793       |
|           | 0,500      | 6,240    | 4,035   | 1,656                   | 1,656          | 66,089 | 4,557 | 1,771 | 0,588       |
|           | 0,146      | 6,594    | 1,000   | 0,410                   | 0,410          | 65,961 | 4,504 | 1,588 | 0,357       |
|           | 0,000      | 6,740    | 0,000   | 0,000                   | 0,000          | 65,892 | 4,496 | 1,500 | 0,000       |

**Tank Calibrations - FW 2 BR**

Fluid Type = Fresh Water      Specific gravity = 1  
 Permeability = 100 %  
 Trim = 0 m (+ve by stern); Heel = 0 deg to starboard

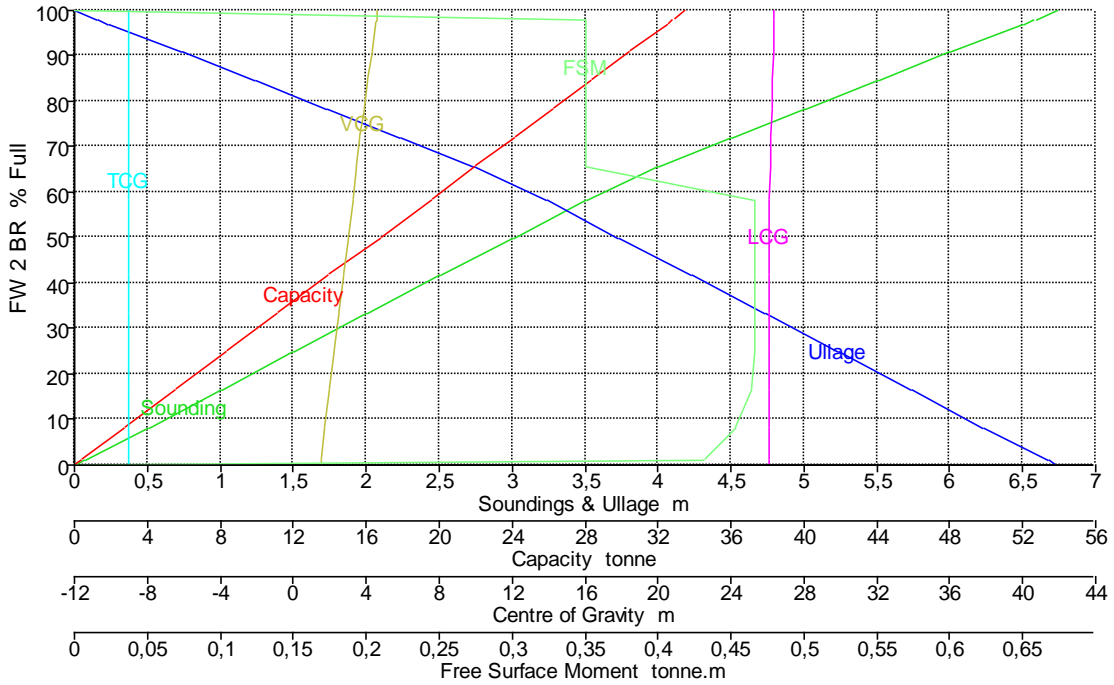

| Tank Name | Sounding m | Ullage m | % Full  | Capacity m <sup>3</sup> | Capacity tonne | LCG m  | TCG m  | VCG m | FSM tonne.m |
|-----------|------------|----------|---------|-------------------------|----------------|--------|--------|-------|-------------|
| FW 2 BR   | 6,740      | 0,000    | 100,000 | 33,477                  | 33,477         | 26,364 | -9,059 | 4,641 | 0,000       |
|           | 6,581      | 0,159    | 98,000  | 32,808                  | 32,808         | 26,355 | -9,059 | 4,570 | 0,350       |
|           | 6,573      | 0,167    | 97,900  | 32,774                  | 32,774         | 26,355 | -9,059 | 4,566 | 0,350       |
|           | 6,500      | 0,240    | 96,989  | 32,469                  | 32,469         | 26,350 | -9,059 | 4,533 | 0,350       |
|           | 6,000      | 0,740    | 90,716  | 30,369                  | 30,369         | 26,319 | -9,059 | 4,311 | 0,350       |
|           | 5,500      | 1,240    | 84,443  | 28,269                  | 28,269         | 26,284 | -9,059 | 4,093 | 0,350       |
|           | 5,000      | 1,740    | 78,170  | 26,169                  | 26,169         | 26,242 | -9,059 | 3,879 | 0,350       |
|           | 4,500      | 2,240    | 71,897  | 24,069                  | 24,069         | 26,194 | -9,059 | 3,673 | 0,350       |
|           | 4,000      | 2,740    | 65,624  | 21,969                  | 21,969         | 26,136 | -9,059 | 3,474 | 0,350       |
|           | 3,500      | 3,240    | 58,348  | 19,533                  | 19,533         | 26,101 | -9,058 | 3,255 | 0,467       |
|           | 3,000      | 3,740    | 49,984  | 16,733                  | 16,733         | 26,101 | -9,058 | 3,005 | 0,467       |
|           | 2,500      | 4,240    | 41,620  | 13,933                  | 13,933         | 26,101 | -9,058 | 2,754 | 0,467       |
|           | 2,000      | 4,740    | 33,256  | 11,133                  | 11,133         | 26,102 | -9,057 | 2,504 | 0,467       |
|           | 1,500      | 5,240    | 24,892  | 8,333                   | 8,333          | 26,102 | -9,056 | 2,253 | 0,467       |
|           | 1,000      | 5,740    | 16,533  | 5,535                   | 5,535          | 26,103 | -9,054 | 2,002 | 0,464       |
|           | 0,500      | 6,240    | 8,214   | 2,750                   | 2,750          | 26,103 | -9,051 | 1,751 | 0,453       |
|           | 0,061      | 6,679    | 1,000   | 0,335                   | 0,335          | 26,103 | -9,046 | 1,531 | 0,432       |
|           | 0,000      | 6,740    | 0,000   | 0,000                   | 0,000          | 26,103 | -9,046 | 1,500 | 0,000       |

**Tank Calibrations - FW 2 ER**

Fluid Type = Fresh Water      Specific gravity = 1  
 Permeability = 100 %  
 Trim = 0 m (+ve by stern); Heel = 0 deg to starboard

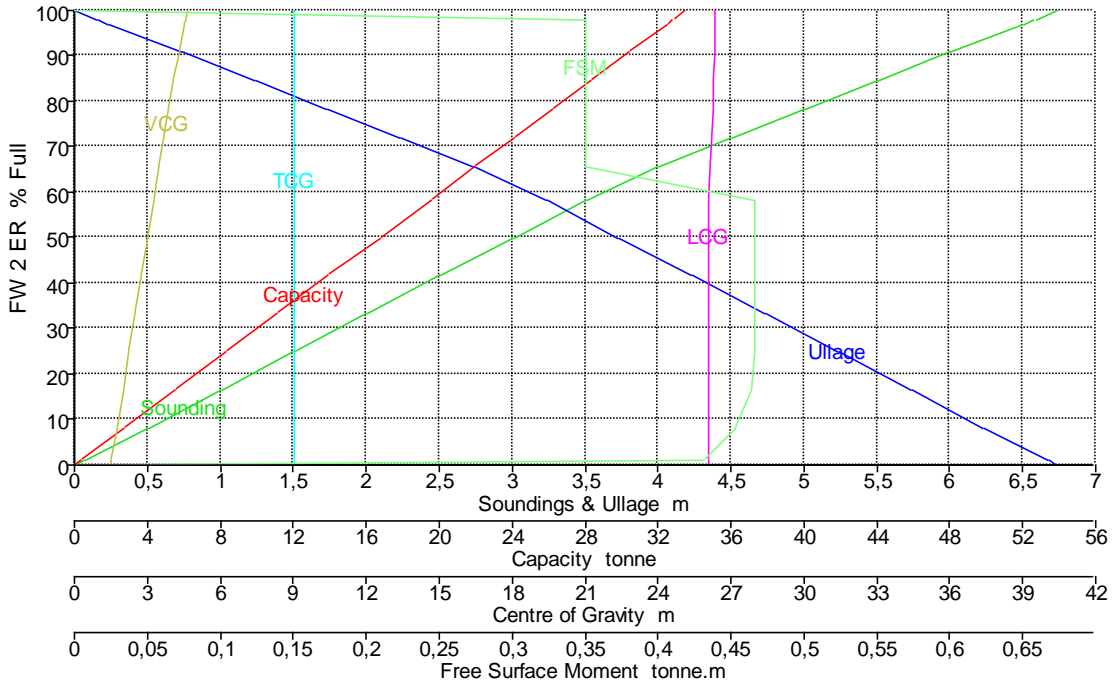

| Tank Name | Sounding m | Ullage m | % Full  | Capacity m <sup>3</sup> | Capacity tonne | LCG m  | TCG m | VCG m | FSM tonne.m |
|-----------|------------|----------|---------|-------------------------|----------------|--------|-------|-------|-------------|
| FW 2 ER   | 6,740      | 0,000    | 100,000 | 33,477                  | 33,477         | 26,364 | 9,059 | 4,641 | 0,000       |
|           | 6,581      | 0,159    | 98,000  | 32,808                  | 32,808         | 26,355 | 9,059 | 4,570 | 0,350       |
|           | 6,573      | 0,167    | 97,900  | 32,774                  | 32,774         | 26,355 | 9,059 | 4,566 | 0,350       |
|           | 6,500      | 0,240    | 96,989  | 32,469                  | 32,469         | 26,350 | 9,059 | 4,533 | 0,350       |
|           | 6,000      | 0,740    | 90,716  | 30,369                  | 30,369         | 26,319 | 9,059 | 4,311 | 0,350       |
|           | 5,500      | 1,240    | 84,443  | 28,269                  | 28,269         | 26,284 | 9,059 | 4,093 | 0,350       |
|           | 5,000      | 1,740    | 78,170  | 26,169                  | 26,169         | 26,242 | 9,059 | 3,879 | 0,350       |
|           | 4,500      | 2,240    | 71,897  | 24,069                  | 24,069         | 26,194 | 9,059 | 3,673 | 0,350       |
|           | 4,000      | 2,740    | 65,624  | 21,969                  | 21,969         | 26,136 | 9,059 | 3,474 | 0,350       |
|           | 3,500      | 3,240    | 58,348  | 19,533                  | 19,533         | 26,101 | 9,058 | 3,255 | 0,467       |
|           | 3,000      | 3,740    | 49,984  | 16,733                  | 16,733         | 26,101 | 9,058 | 3,005 | 0,467       |
|           | 2,500      | 4,240    | 41,620  | 13,933                  | 13,933         | 26,101 | 9,058 | 2,754 | 0,467       |
|           | 2,000      | 4,740    | 33,256  | 11,133                  | 11,133         | 26,102 | 9,057 | 2,504 | 0,467       |
|           | 1,500      | 5,240    | 24,892  | 8,333                   | 8,333          | 26,102 | 9,056 | 2,253 | 0,467       |
|           | 1,000      | 5,740    | 16,533  | 5,535                   | 5,535          | 26,103 | 9,054 | 2,002 | 0,464       |
|           | 0,500      | 6,240    | 8,214   | 2,750                   | 2,750          | 26,103 | 9,051 | 1,751 | 0,453       |
|           | 0,061      | 6,679    | 1,000   | 0,335                   | 0,335          | 26,103 | 9,046 | 1,531 | 0,432       |
|           | 0,000      | 6,740    | 0,000   | 0,000                   | 0,000          | 26,103 | 9,046 | 1,500 | 0,000       |

### Tank Calibrations - FW 3 BR

Fluid Type = Fresh Water      Specific gravity = 1  
 Permeability = 100 %  
 Trim = 0 m (+ve by stern); Heel = 0 deg to starboard



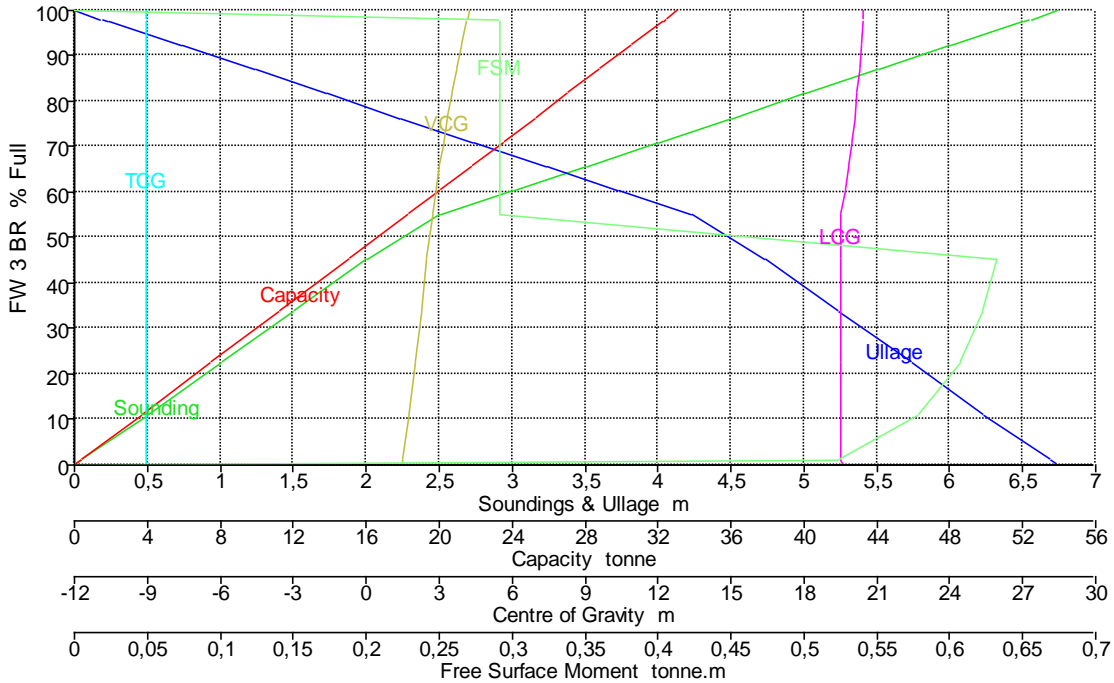

| Tank Name | Sounding m | Ullage m | % Full  | Capacity m <sup>3</sup> | Capacity tonne | LCG m  | TCG m  | VCG m | FSM tonne.m |
|-----------|------------|----------|---------|-------------------------|----------------|--------|--------|-------|-------------|
| FW 3 BR   | 6,740      | 0,000    | 100,000 | 33,066                  | 33,066         | 20,442 | -9,054 | 4,247 | 0,000       |
|           | 6,551      | 0,189    | 98,000  | 32,405                  | 32,405         | 20,419 | -9,054 | 4,168 | 0,292       |
|           | 6,542      | 0,198    | 97,900  | 32,372                  | 32,372         | 20,418 | -9,054 | 4,164 | 0,292       |
|           | 6,500      | 0,240    | 97,460  | 32,226                  | 32,226         | 20,413 | -9,054 | 4,146 | 0,292       |
|           | 6,000      | 0,740    | 92,167  | 30,476                  | 30,476         | 20,348 | -9,054 | 3,939 | 0,292       |
|           | 5,500      | 1,240    | 86,875  | 28,726                  | 28,726         | 20,274 | -9,054 | 3,738 | 0,292       |
|           | 5,000      | 1,740    | 81,582  | 26,976                  | 26,976         | 20,192 | -9,053 | 3,542 | 0,292       |
|           | 4,500      | 2,240    | 76,290  | 25,226                  | 25,226         | 20,098 | -9,053 | 3,354 | 0,292       |
|           | 4,000      | 2,740    | 70,998  | 23,476                  | 23,476         | 19,989 | -9,052 | 3,176 | 0,292       |
|           | 3,500      | 3,240    | 65,705  | 21,726                  | 21,726         | 19,864 | -9,051 | 3,009 | 0,292       |
|           | 3,000      | 3,740    | 60,413  | 19,976                  | 19,976         | 19,716 | -9,051 | 2,856 | 0,292       |
|           | 2,500      | 4,240    | 55,121  | 18,226                  | 18,226         | 19,540 | -9,050 | 2,722 | 0,292       |
|           | 2,000      | 4,740    | 45,415  | 15,017                  | 15,017         | 19,484 | -9,048 | 2,510 | 0,632       |
|           | 1,500      | 5,240    | 33,857  | 11,195                  | 11,195         | 19,491 | -9,045 | 2,258 | 0,623       |
|           | 1,000      | 5,740    | 22,375  | 7,399                   | 7,399          | 19,500 | -9,041 | 2,005 | 0,607       |
|           | 0,500      | 6,240    | 11,035  | 3,649                   | 3,649          | 19,517 | -9,034 | 1,752 | 0,578       |
|           | 0,046      | 6,694    | 1,000   | 0,331                   | 0,331          | 19,546 | -9,024 | 1,523 | 0,522       |
|           | 0,000      | 6,740    | 0,000   | 0,000                   | 0,000          | 19,551 | -9,023 | 1,500 | 0,000       |

**Tank Calibrations - FW 3 ER**

Fluid Type = Fresh Water      Specific gravity = 1  
 Permeability = 100 %  
 Trim = 0 m (+ve by stern); Heel = 0 deg to starboard

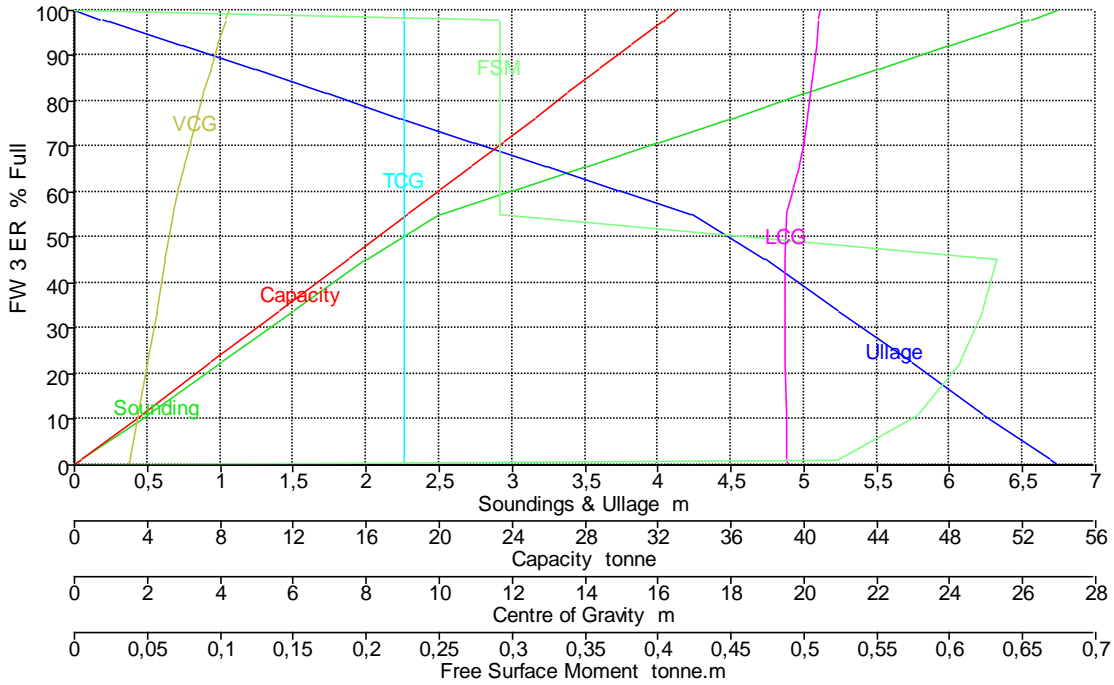

| Tank Name | Sounding m | Ullage m | % Full  | Capacity m <sup>3</sup> | Capacity tonne | LCG m  | TCG m | VCG m | FSM tonne.m |
|-----------|------------|----------|---------|-------------------------|----------------|--------|-------|-------|-------------|
| FW 3 ER   | 6,740      | 0,000    | 100,000 | 33,066                  | 33,066         | 20,442 | 9,054 | 4,247 | 0,000       |
|           | 6,551      | 0,189    | 98,000  | 32,405                  | 32,405         | 20,419 | 9,054 | 4,168 | 0,292       |
|           | 6,542      | 0,198    | 97,900  | 32,372                  | 32,372         | 20,418 | 9,054 | 4,164 | 0,292       |
|           | 6,500      | 0,240    | 97,460  | 32,226                  | 32,226         | 20,413 | 9,054 | 4,146 | 0,292       |
|           | 6,000      | 0,740    | 92,167  | 30,476                  | 30,476         | 20,348 | 9,054 | 3,939 | 0,292       |
|           | 5,500      | 1,240    | 86,875  | 28,726                  | 28,726         | 20,274 | 9,054 | 3,738 | 0,292       |
|           | 5,000      | 1,740    | 81,582  | 26,976                  | 26,976         | 20,192 | 9,053 | 3,542 | 0,292       |
|           | 4,500      | 2,240    | 76,290  | 25,226                  | 25,226         | 20,098 | 9,053 | 3,354 | 0,292       |
|           | 4,000      | 2,740    | 70,998  | 23,476                  | 23,476         | 19,989 | 9,052 | 3,176 | 0,292       |
|           | 3,500      | 3,240    | 65,705  | 21,726                  | 21,726         | 19,864 | 9,051 | 3,009 | 0,292       |
|           | 3,000      | 3,740    | 60,413  | 19,976                  | 19,976         | 19,716 | 9,051 | 2,856 | 0,292       |
|           | 2,500      | 4,240    | 55,121  | 18,226                  | 18,226         | 19,540 | 9,050 | 2,722 | 0,292       |
|           | 2,000      | 4,740    | 45,415  | 15,017                  | 15,017         | 19,484 | 9,048 | 2,510 | 0,632       |
|           | 1,500      | 5,240    | 33,857  | 11,195                  | 11,195         | 19,491 | 9,045 | 2,258 | 0,623       |
|           | 1,000      | 5,740    | 22,375  | 7,399                   | 7,399          | 19,500 | 9,041 | 2,005 | 0,607       |
|           | 0,500      | 6,240    | 11,035  | 3,649                   | 3,649          | 19,517 | 9,034 | 1,752 | 0,578       |
|           | 0,046      | 6,694    | 1,000   | 0,331                   | 0,331          | 19,546 | 9,024 | 1,523 | 0,522       |
|           | 0,000      | 6,740    | 0,000   | 0,000                   | 0,000          | 19,551 | 9,023 | 1,500 | 0,000       |

**Tank Calibrations - FW 4 BR**

Fluid Type = Fresh Water      Specific gravity = 1  
 Permeability = 100 %  
 Trim = 0 m (+ve by stern); Heel = 0 deg to starboard

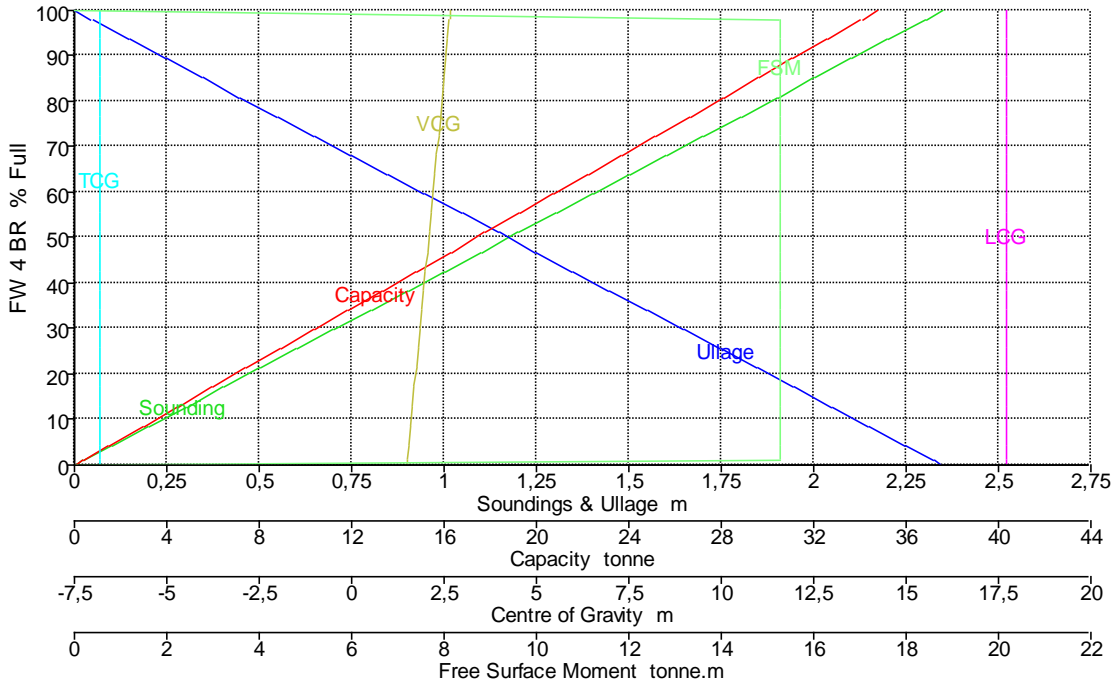

| Tank Name | Sounding m | Ullage m | % Full  | Capacity m <sup>3</sup> | Capacity tonne | LCG m  | TCG m  | VCG m | FSM tonne.m |
|-----------|------------|----------|---------|-------------------------|----------------|--------|--------|-------|-------------|
| FW 4 BR   | 2,350      | 0,000    | 100,000 | 34,742                  | 34,742         | 17,700 | -6,800 | 2,675 | 0,000       |
|           | 2,303      | 0,047    | 98,000  | 34,048                  | 34,048         | 17,700 | -6,800 | 2,652 | 15,265      |
|           | 2,301      | 0,049    | 97,900  | 34,013                  | 34,013         | 17,700 | -6,800 | 2,650 | 15,265      |
|           | 2,300      | 0,050    | 97,872  | 34,003                  | 34,003         | 17,700 | -6,800 | 2,650 | 15,265      |
|           | 2,200      | 0,150    | 93,617  | 32,525                  | 32,525         | 17,700 | -6,800 | 2,600 | 15,265      |
|           | 2,100      | 0,250    | 89,362  | 31,046                  | 31,046         | 17,700 | -6,800 | 2,550 | 15,265      |
|           | 2,000      | 0,350    | 85,106  | 29,568                  | 29,568         | 17,700 | -6,800 | 2,500 | 15,265      |
|           | 1,900      | 0,450    | 80,851  | 28,090                  | 28,090         | 17,700 | -6,800 | 2,450 | 15,265      |
|           | 1,800      | 0,550    | 76,596  | 26,611                  | 26,611         | 17,700 | -6,800 | 2,400 | 15,265      |
|           | 1,700      | 0,650    | 72,340  | 25,133                  | 25,133         | 17,700 | -6,800 | 2,350 | 15,265      |
|           | 1,600      | 0,750    | 68,085  | 23,654                  | 23,654         | 17,700 | -6,800 | 2,300 | 15,265      |
|           | 1,500      | 0,850    | 63,830  | 22,176                  | 22,176         | 17,700 | -6,800 | 2,250 | 15,265      |
|           | 1,400      | 0,950    | 59,574  | 20,698                  | 20,698         | 17,700 | -6,800 | 2,200 | 15,265      |
|           | 1,300      | 1,050    | 55,319  | 19,219                  | 19,219         | 17,700 | -6,800 | 2,150 | 15,265      |
|           | 1,200      | 1,150    | 51,064  | 17,741                  | 17,741         | 17,700 | -6,800 | 2,100 | 15,265      |
|           | 1,100      | 1,250    | 46,809  | 16,262                  | 16,262         | 17,700 | -6,800 | 2,050 | 15,265      |
|           | 1,000      | 1,350    | 42,553  | 14,784                  | 14,784         | 17,700 | -6,800 | 2,000 | 15,265      |
|           | 0,900      | 1,450    | 38,298  | 13,306                  | 13,306         | 17,700 | -6,800 | 1,950 | 15,265      |
|           | 0,800      | 1,550    | 34,043  | 11,827                  | 11,827         | 17,700 | -6,800 | 1,900 | 15,265      |
|           | 0,700      | 1,650    | 29,787  | 10,349                  | 10,349         | 17,700 | -6,800 | 1,850 | 15,265      |
|           | 0,600      | 1,750    | 25,532  | 8,870                   | 8,870          | 17,700 | -6,800 | 1,800 | 15,265      |
|           | 0,500      | 1,850    | 21,277  | 7,392                   | 7,392          | 17,700 | -6,800 | 1,750 | 15,265      |
|           | 0,400      | 1,950    | 17,021  | 5,914                   | 5,914          | 17,700 | -6,800 | 1,700 | 15,265      |
|           | 0,300      | 2,050    | 12,766  | 4,435                   | 4,435          | 17,700 | -6,800 | 1,650 | 15,265      |
|           | 0,200      | 2,150    | 8,511   | 2,957                   | 2,957          | 17,700 | -6,800 | 1,600 | 15,265      |
|           | 0,100      | 2,250    | 4,255   | 1,478                   | 1,478          | 17,700 | -6,800 | 1,550 | 15,265      |
|           | 0,024      | 2,327    | 1,000   | 0,347                   | 0,347          | 17,700 | -6,800 | 1,512 | 15,265      |
|           | 0,000      | 2,350    | 0,000   | 0,000                   | 0,000          | 17,700 | -6,800 | 1,500 | 0,000       |

Tank Calibrations - FW 4 ER

Fluid Type = Fresh Water    Specific gravity = 1  
 Permeability = 100 %  
 Trim = 0 m (+ve by stern); Heel = 0 deg to starboard

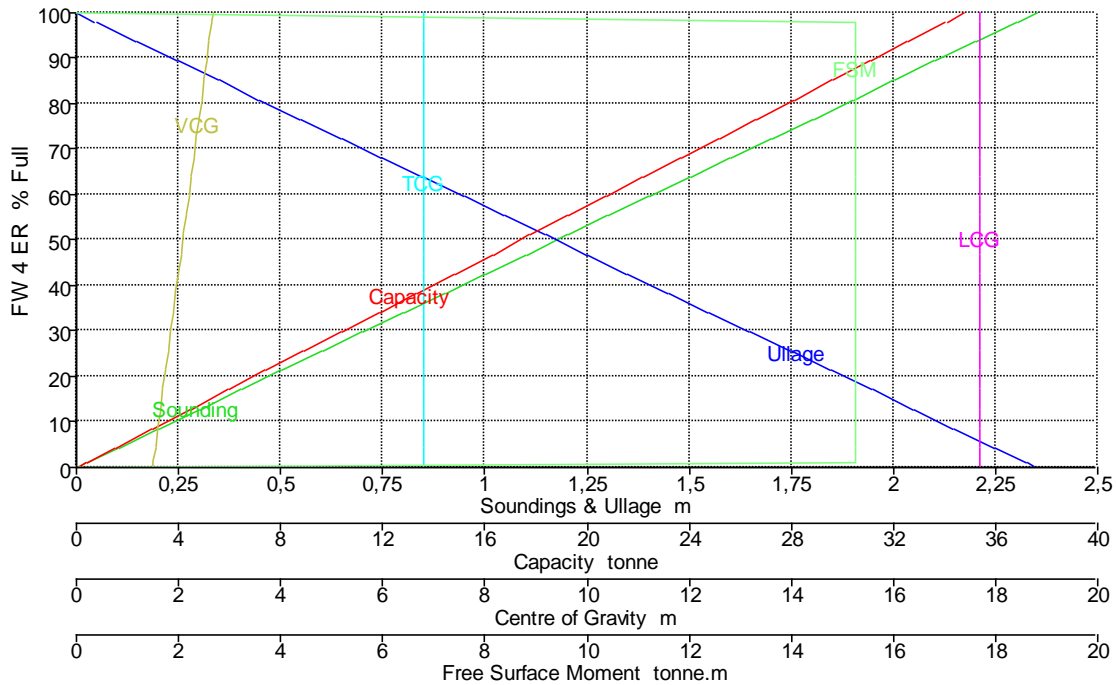

| Tank Name | Sounding m | Ullage m | % Full  | Capacity m <sup>3</sup> | Capacity tonne | LCG m  | TCG m | VCG m | FSM tonne.m |
|-----------|------------|----------|---------|-------------------------|----------------|--------|-------|-------|-------------|
| FW 4 ER   | 2,350      | 0,000    | 100,000 | 34,742                  | 34,742         | 17,700 | 6,800 | 2,675 | 0,000       |
|           | 2,303      | 0,047    | 98,000  | 34,048                  | 34,048         | 17,700 | 6,800 | 2,652 | 15,265      |
|           | 2,301      | 0,049    | 97,900  | 34,013                  | 34,013         | 17,700 | 6,800 | 2,650 | 15,265      |
|           | 2,300      | 0,050    | 97,872  | 34,003                  | 34,003         | 17,700 | 6,800 | 2,650 | 15,265      |
|           | 2,200      | 0,150    | 93,617  | 32,525                  | 32,525         | 17,700 | 6,800 | 2,600 | 15,265      |
|           | 2,100      | 0,250    | 89,362  | 31,046                  | 31,046         | 17,700 | 6,800 | 2,550 | 15,265      |
|           | 2,000      | 0,350    | 85,106  | 29,568                  | 29,568         | 17,700 | 6,800 | 2,500 | 15,265      |
|           | 1,900      | 0,450    | 80,851  | 28,090                  | 28,090         | 17,700 | 6,800 | 2,450 | 15,265      |
|           | 1,800      | 0,550    | 76,596  | 26,611                  | 26,611         | 17,700 | 6,800 | 2,400 | 15,265      |
|           | 1,700      | 0,650    | 72,340  | 25,133                  | 25,133         | 17,700 | 6,800 | 2,350 | 15,265      |
|           | 1,600      | 0,750    | 68,085  | 23,654                  | 23,654         | 17,700 | 6,800 | 2,300 | 15,265      |
|           | 1,500      | 0,850    | 63,830  | 22,176                  | 22,176         | 17,700 | 6,800 | 2,250 | 15,265      |
|           | 1,400      | 0,950    | 59,574  | 20,698                  | 20,698         | 17,700 | 6,800 | 2,200 | 15,265      |
|           | 1,300      | 1,050    | 55,319  | 19,219                  | 19,219         | 17,700 | 6,800 | 2,150 | 15,265      |
|           | 1,200      | 1,150    | 51,064  | 17,741                  | 17,741         | 17,700 | 6,800 | 2,100 | 15,265      |
|           | 1,100      | 1,250    | 46,809  | 16,262                  | 16,262         | 17,700 | 6,800 | 2,050 | 15,265      |
|           | 1,000      | 1,350    | 42,553  | 14,784                  | 14,784         | 17,700 | 6,800 | 2,000 | 15,265      |
|           | 0,900      | 1,450    | 38,298  | 13,306                  | 13,306         | 17,700 | 6,800 | 1,950 | 15,265      |
|           | 0,800      | 1,550    | 34,043  | 11,827                  | 11,827         | 17,700 | 6,800 | 1,900 | 15,265      |
|           | 0,700      | 1,650    | 29,787  | 10,349                  | 10,349         | 17,700 | 6,800 | 1,850 | 15,265      |
|           | 0,600      | 1,750    | 25,532  | 8,870                   | 8,870          | 17,700 | 6,800 | 1,800 | 15,265      |
|           | 0,500      | 1,850    | 21,277  | 7,392                   | 7,392          | 17,700 | 6,800 | 1,750 | 15,265      |
|           | 0,400      | 1,950    | 17,021  | 5,914                   | 5,914          | 17,700 | 6,800 | 1,700 | 15,265      |
|           | 0,300      | 2,050    | 12,766  | 4,435                   | 4,435          | 17,700 | 6,800 | 1,650 | 15,265      |
|           | 0,200      | 2,150    | 8,511   | 2,957                   | 2,957          | 17,700 | 6,800 | 1,600 | 15,265      |
|           | 0,100      | 2,250    | 4,255   | 1,478                   | 1,478          | 17,700 | 6,800 | 1,550 | 15,265      |
|           | 0,024      | 2,327    | 1,000   | 0,347                   | 0,347          | 17,700 | 6,800 | 1,512 | 15,265      |
|           | 0,000      | 2,350    | 0,000   | 0,000                   | 0,000          | 17,700 | 6,800 | 1,500 | 0,000       |

### Tank Calibrations - FW 5 BR

Fluid Type = Fresh Water    Specific gravity = 1  
 Permeability = 100 %  
 Trim = 0 m (+ve by stern); Heel = 0 deg to starboard

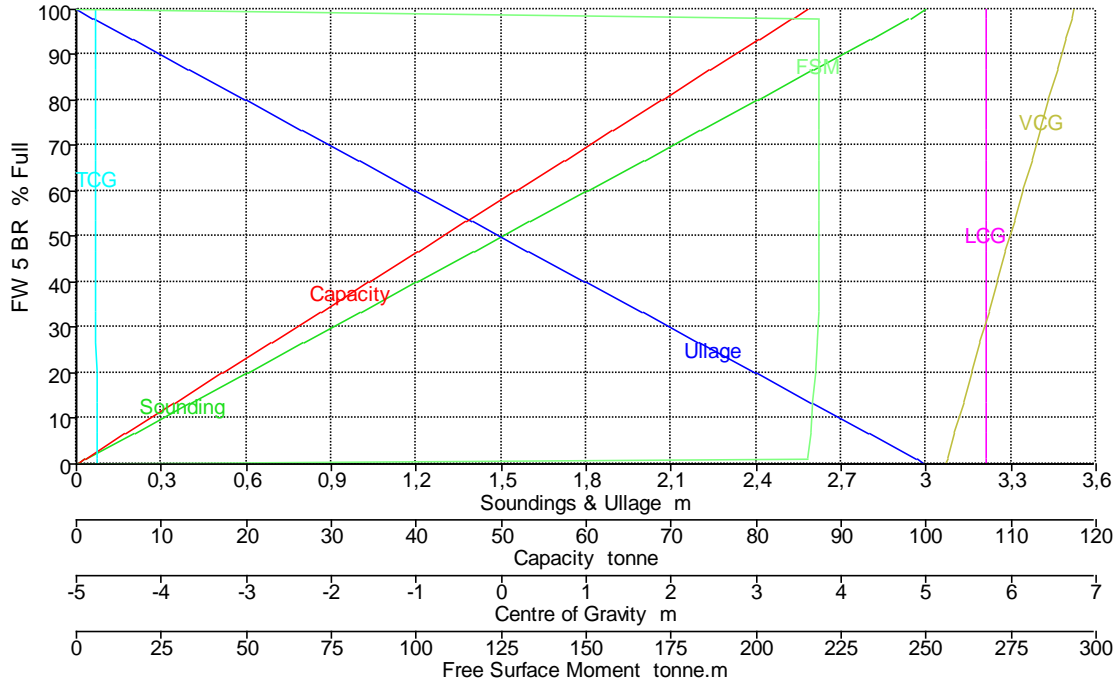

| Tank Name | Sounding m | Ullage m | % Full  | Capacity m <sup>3</sup> | Capacity tonne | LCG m | TCG m  | VCG m | FSM tonne.m |
|-----------|------------|----------|---------|-------------------------|----------------|-------|--------|-------|-------------|
| FW 5 BR   | 3,000      | 0,000    | 100,000 | 85,973                  | 85,973         | 5,700 | -4,776 | 6,741 | 0,000       |
|           | 2,940      | 0,060    | 98,000  | 84,254                  | 84,254         | 5,700 | -4,776 | 6,711 | 218,431     |
|           | 2,937      | 0,063    | 97,900  | 84,168                  | 84,168         | 5,700 | -4,776 | 6,709 | 218,431     |
|           | 2,800      | 0,200    | 93,328  | 80,237                  | 80,237         | 5,700 | -4,776 | 6,641 | 218,431     |
|           | 2,600      | 0,400    | 86,656  | 74,501                  | 74,501         | 5,700 | -4,776 | 6,541 | 218,431     |
|           | 2,400      | 0,600    | 79,985  | 68,765                  | 68,765         | 5,700 | -4,775 | 6,441 | 218,431     |
|           | 2,200      | 0,800    | 73,313  | 63,029                  | 63,029         | 5,700 | -4,775 | 6,341 | 218,431     |
|           | 2,000      | 1,000    | 66,641  | 57,293                  | 57,293         | 5,700 | -4,774 | 6,241 | 218,431     |
|           | 1,800      | 1,200    | 59,969  | 51,557                  | 51,557         | 5,700 | -4,774 | 6,141 | 218,431     |
|           | 1,600      | 1,400    | 53,297  | 45,821                  | 45,821         | 5,700 | -4,773 | 6,041 | 218,431     |
|           | 1,400      | 1,600    | 46,625  | 40,085                  | 40,085         | 5,700 | -4,772 | 5,941 | 218,431     |
|           | 1,200      | 1,800    | 39,954  | 34,349                  | 34,349         | 5,701 | -4,771 | 5,841 | 218,420     |
|           | 1,000      | 2,000    | 33,283  | 28,614                  | 28,614         | 5,701 | -4,769 | 5,740 | 218,233     |
|           | 0,800      | 2,200    | 26,615  | 22,881                  | 22,881         | 5,701 | -4,767 | 5,640 | 217,866     |
|           | 0,600      | 2,400    | 19,951  | 17,152                  | 17,152         | 5,701 | -4,765 | 5,540 | 217,384     |
|           | 0,400      | 2,600    | 13,293  | 11,428                  | 11,428         | 5,701 | -4,762 | 5,440 | 216,765     |
|           | 0,200      | 2,800    | 6,642   | 5,710                   | 5,710          | 5,701 | -4,758 | 5,340 | 215,974     |
|           | 0,030      | 2,970    | 1,000   | 0,860                   | 0,860          | 5,701 | -4,755 | 5,255 | 215,139     |
|           | 0,000      | 3,000    | 0,000   | 0,000                   | 0,000          | 5,701 | -4,755 | 5,240 | 0,000       |

### Tank Calibrations - FW 5 ER

Fluid Type = Fresh Water    Specific gravity = 1  
 Permeability = 100 %  
 Trim = 0 m (+ve by stern); Heel = 0 deg to starboard

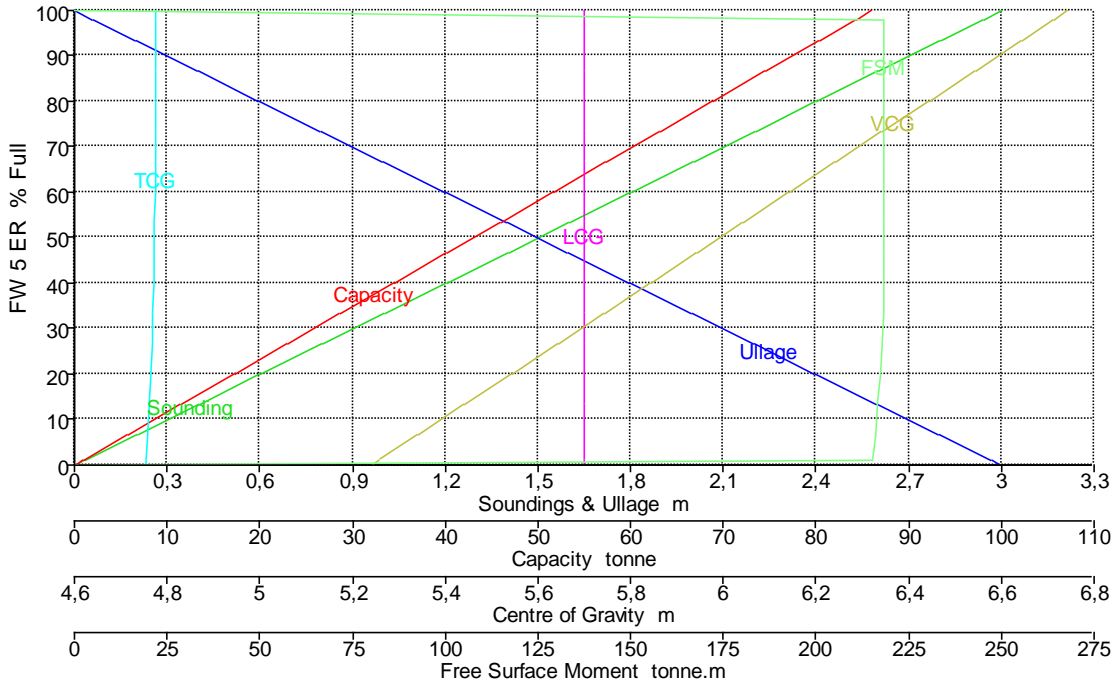

| Tank Name | Sounding m | Ullage m | % Full  | Capacity m <sup>3</sup> | Capacity tonne | LCG m | TCG m | VCG m | FSM tonne.m |
|-----------|------------|----------|---------|-------------------------|----------------|-------|-------|-------|-------------|
| FW 5 ER   | 3,000      | 0,000    | 100,000 | 85,973                  | 85,973         | 5,700 | 4,776 | 6,741 | 0,000       |
|           | 2,940      | 0,060    | 98,000  | 84,254                  | 84,254         | 5,700 | 4,776 | 6,711 | 218,431     |
|           | 2,937      | 0,063    | 97,900  | 84,168                  | 84,168         | 5,700 | 4,776 | 6,709 | 218,431     |
|           | 2,800      | 0,200    | 93,328  | 80,237                  | 80,237         | 5,700 | 4,776 | 6,641 | 218,431     |
|           | 2,600      | 0,400    | 86,656  | 74,501                  | 74,501         | 5,700 | 4,776 | 6,541 | 218,431     |
|           | 2,400      | 0,600    | 79,985  | 68,765                  | 68,765         | 5,700 | 4,775 | 6,441 | 218,431     |
|           | 2,200      | 0,800    | 73,313  | 63,029                  | 63,029         | 5,700 | 4,775 | 6,341 | 218,431     |
|           | 2,000      | 1,000    | 66,641  | 57,293                  | 57,293         | 5,700 | 4,774 | 6,241 | 218,431     |
|           | 1,800      | 1,200    | 59,969  | 51,557                  | 51,557         | 5,700 | 4,774 | 6,141 | 218,431     |
|           | 1,600      | 1,400    | 53,297  | 45,821                  | 45,821         | 5,700 | 4,773 | 6,041 | 218,431     |
|           | 1,400      | 1,600    | 46,625  | 40,085                  | 40,085         | 5,700 | 4,772 | 5,941 | 218,431     |
|           | 1,200      | 1,800    | 39,954  | 34,349                  | 34,349         | 5,701 | 4,771 | 5,841 | 218,420     |
|           | 1,000      | 2,000    | 33,283  | 28,614                  | 28,614         | 5,701 | 4,769 | 5,740 | 218,233     |
|           | 0,800      | 2,200    | 26,615  | 22,881                  | 22,881         | 5,701 | 4,767 | 5,640 | 217,866     |
|           | 0,600      | 2,400    | 19,951  | 17,152                  | 17,152         | 5,701 | 4,765 | 5,540 | 217,384     |
|           | 0,400      | 2,600    | 13,293  | 11,428                  | 11,428         | 5,701 | 4,762 | 5,440 | 216,765     |
|           | 0,200      | 2,800    | 6,642   | 5,710                   | 5,710          | 5,701 | 4,758 | 5,340 | 215,974     |
|           | 0,030      | 2,970    | 1,000   | 0,860                   | 0,860          | 5,701 | 4,755 | 5,255 | 215,139     |
|           | 0,000      | 3,000    | 0,000   | 0,000                   | 0,000          | 5,701 | 4,755 | 5,240 | 0,000       |

**Tank Calibrations - DO 1 BR**

Fluid Type = Diesel      Specific gravity = 0,84  
 Permeability = 100 %  
 Trim = 0 m (+ve by stern); Heel = 0 deg to starboard

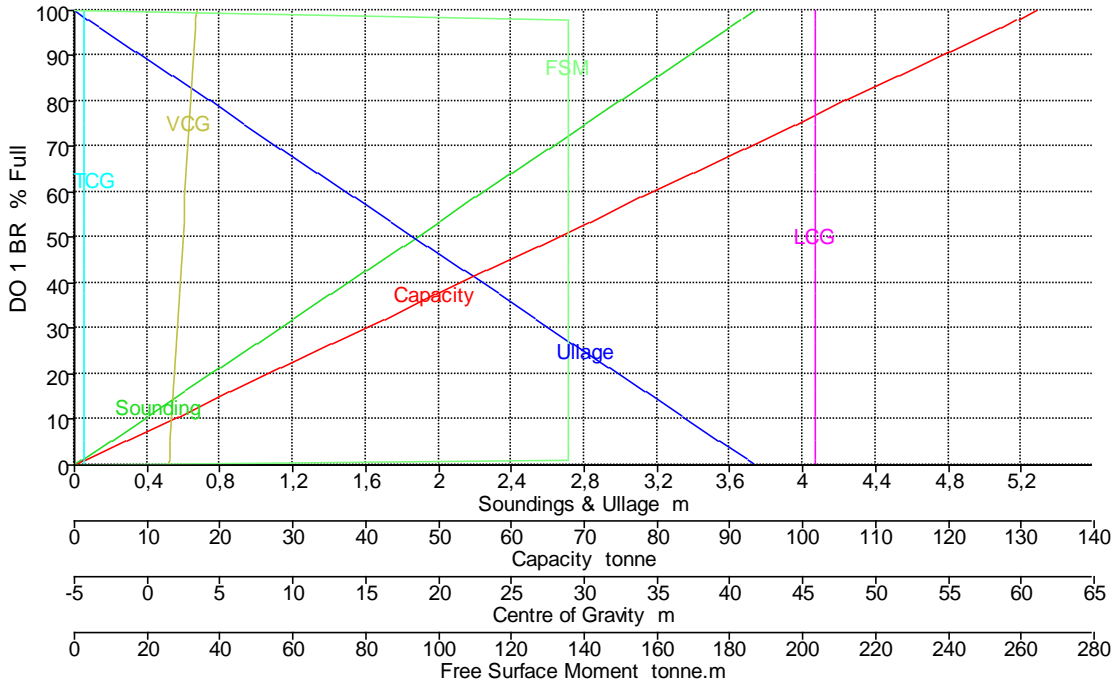

| Tank Name | Sounding m | Ullage m | % Full  | Capacity m <sup>3</sup> | Capacity tonne | LCG m  | TCG m  | VCG m | FSM tonne.m |
|-----------|------------|----------|---------|-------------------------|----------------|--------|--------|-------|-------------|
| DO 1 BR   | 3,740      | 0,000    | 100,000 | 157,276                 | 132,112        | 45,914 | -4,356 | 3,370 | 0,000       |
|           | 3,665      | 0,075    | 98,000  | 154,131                 | 129,470        | 45,914 | -4,356 | 3,333 | 135,649     |
|           | 3,661      | 0,079    | 97,900  | 153,974                 | 129,338        | 45,914 | -4,356 | 3,331 | 135,649     |
|           | 3,600      | 0,140    | 96,257  | 151,389                 | 127,167        | 45,914 | -4,356 | 3,300 | 135,649     |
|           | 3,400      | 0,340    | 90,909  | 142,978                 | 120,102        | 45,914 | -4,356 | 3,200 | 135,649     |
|           | 3,200      | 0,540    | 85,561  | 134,568                 | 113,037        | 45,914 | -4,356 | 3,100 | 135,649     |
|           | 3,000      | 0,740    | 80,214  | 126,157                 | 105,972        | 45,914 | -4,356 | 3,000 | 135,649     |
|           | 2,800      | 0,940    | 74,866  | 117,747                 | 98,907         | 45,914 | -4,356 | 2,900 | 135,649     |
|           | 2,600      | 1,140    | 69,519  | 109,336                 | 91,843         | 45,914 | -4,356 | 2,800 | 135,649     |
|           | 2,400      | 1,340    | 64,171  | 100,926                 | 84,778         | 45,914 | -4,356 | 2,700 | 135,649     |
|           | 2,200      | 1,540    | 58,824  | 92,515                  | 77,713         | 45,914 | -4,356 | 2,600 | 135,649     |
|           | 2,000      | 1,740    | 53,476  | 84,105                  | 70,648         | 45,914 | -4,356 | 2,500 | 135,649     |
|           | 1,800      | 1,940    | 48,128  | 75,694                  | 63,583         | 45,914 | -4,356 | 2,400 | 135,649     |
|           | 1,600      | 2,140    | 42,781  | 67,284                  | 56,519         | 45,914 | -4,356 | 2,300 | 135,649     |
|           | 1,400      | 2,340    | 37,433  | 58,873                  | 49,454         | 45,914 | -4,356 | 2,200 | 135,649     |
|           | 1,200      | 2,540    | 32,086  | 50,463                  | 42,389         | 45,914 | -4,356 | 2,100 | 135,649     |
|           | 1,000      | 2,740    | 26,738  | 42,052                  | 35,324         | 45,914 | -4,356 | 2,000 | 135,649     |
|           | 0,800      | 2,940    | 21,390  | 33,642                  | 28,259         | 45,914 | -4,356 | 1,900 | 135,649     |
|           | 0,600      | 3,140    | 16,043  | 25,231                  | 21,194         | 45,914 | -4,356 | 1,800 | 135,649     |
|           | 0,400      | 3,340    | 10,695  | 16,821                  | 14,130         | 45,914 | -4,356 | 1,700 | 135,649     |
|           | 0,200      | 3,540    | 5,348   | 8,410                   | 7,065          | 45,914 | -4,356 | 1,600 | 135,649     |
|           | 0,037      | 3,703    | 1,000   | 1,573                   | 1,321          | 45,914 | -4,356 | 1,519 | 135,649     |
|           | 0,000      | 3,740    | 0,000   | 0,000                   | 0,000          | 45,914 | -4,356 | 1,500 | 0,000       |

**Tank Calibrations - DO 1 ER**

Fluid Type = Diesel    Specific gravity = 0,84  
 Permeability = 100 %  
 Trim = 0 m (+ve by stern); Heel = 0 deg to starboard

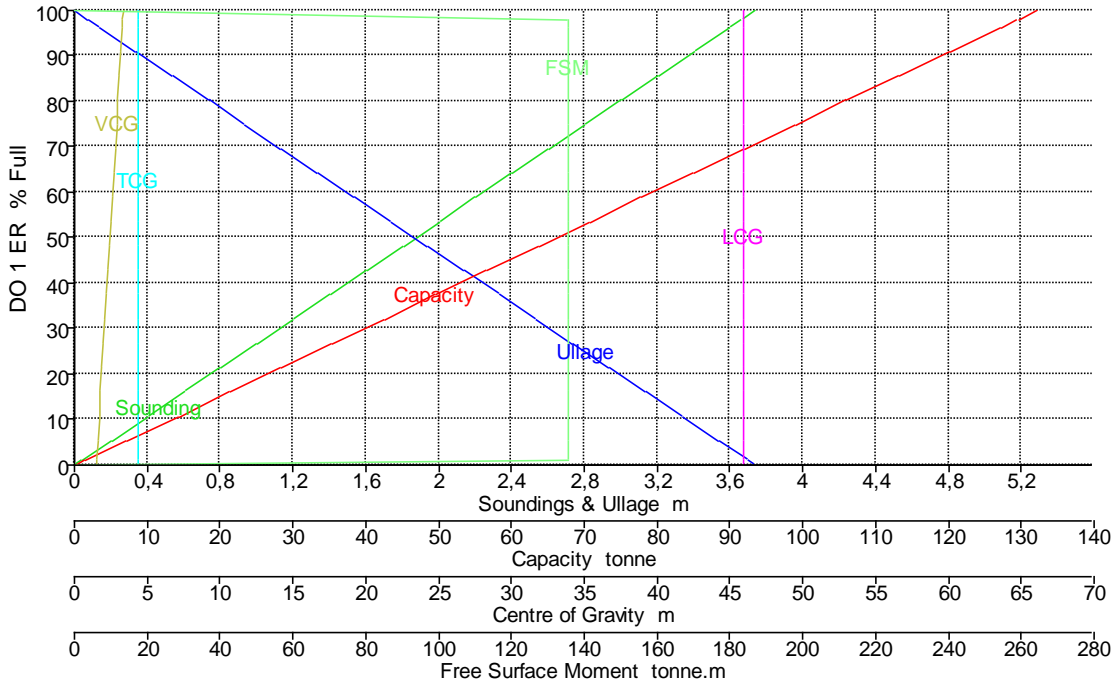

| Tank Name | Sounding m | Ullage m | % Full  | Capacity m <sup>3</sup> | Capacity tonne | LCG m  | TCG m | VCG m | FSM tonne.m |
|-----------|------------|----------|---------|-------------------------|----------------|--------|-------|-------|-------------|
| DO 1 ER   | 3,740      | 0,000    | 100,000 | 157,276                 | 132,112        | 45,914 | 4,356 | 3,370 | 0,000       |
|           | 3,665      | 0,075    | 98,000  | 154,131                 | 129,470        | 45,914 | 4,356 | 3,333 | 135,649     |
|           | 3,661      | 0,079    | 97,900  | 153,974                 | 129,338        | 45,914 | 4,356 | 3,331 | 135,649     |
|           | 3,600      | 0,140    | 96,257  | 151,389                 | 127,167        | 45,914 | 4,356 | 3,300 | 135,649     |
|           | 3,400      | 0,340    | 90,909  | 142,978                 | 120,102        | 45,914 | 4,356 | 3,200 | 135,649     |
|           | 3,200      | 0,540    | 85,561  | 134,568                 | 113,037        | 45,914 | 4,356 | 3,100 | 135,649     |
|           | 3,000      | 0,740    | 80,214  | 126,157                 | 105,972        | 45,914 | 4,356 | 3,000 | 135,649     |
|           | 2,800      | 0,940    | 74,866  | 117,747                 | 98,907         | 45,914 | 4,356 | 2,900 | 135,649     |
|           | 2,600      | 1,140    | 69,519  | 109,336                 | 91,843         | 45,914 | 4,356 | 2,800 | 135,649     |
|           | 2,400      | 1,340    | 64,171  | 100,926                 | 84,778         | 45,914 | 4,356 | 2,700 | 135,649     |
|           | 2,200      | 1,540    | 58,824  | 92,515                  | 77,713         | 45,914 | 4,356 | 2,600 | 135,649     |
|           | 2,000      | 1,740    | 53,476  | 84,105                  | 70,648         | 45,914 | 4,356 | 2,500 | 135,649     |
|           | 1,800      | 1,940    | 48,128  | 75,694                  | 63,583         | 45,914 | 4,356 | 2,400 | 135,649     |
|           | 1,600      | 2,140    | 42,781  | 67,284                  | 56,519         | 45,914 | 4,356 | 2,300 | 135,649     |
|           | 1,400      | 2,340    | 37,433  | 58,873                  | 49,454         | 45,914 | 4,356 | 2,200 | 135,649     |
|           | 1,200      | 2,540    | 32,086  | 50,463                  | 42,389         | 45,914 | 4,356 | 2,100 | 135,649     |
|           | 1,000      | 2,740    | 26,738  | 42,052                  | 35,324         | 45,914 | 4,356 | 2,000 | 135,649     |
|           | 0,800      | 2,940    | 21,390  | 33,642                  | 28,259         | 45,914 | 4,356 | 1,900 | 135,649     |
|           | 0,600      | 3,140    | 16,043  | 25,231                  | 21,194         | 45,914 | 4,356 | 1,800 | 135,649     |
|           | 0,400      | 3,340    | 10,695  | 16,821                  | 14,130         | 45,914 | 4,356 | 1,700 | 135,649     |
|           | 0,200      | 3,540    | 5,348   | 8,410                   | 7,065          | 45,914 | 4,356 | 1,600 | 135,649     |
|           | 0,037      | 3,703    | 1,000   | 1,573                   | 1,321          | 45,914 | 4,356 | 1,519 | 135,649     |
|           | 0,000      | 3,740    | 0,000   | 0,000                   | 0,000          | 45,914 | 4,356 | 1,500 | 0,000       |

**Tank Calibrations - DO 2 BR**

Fluid Type = Diesel      Specific gravity = 0,84  
 Permeability = 100 %  
 Trim = 0 m (+ve by stern); Heel = 0 deg to starboard



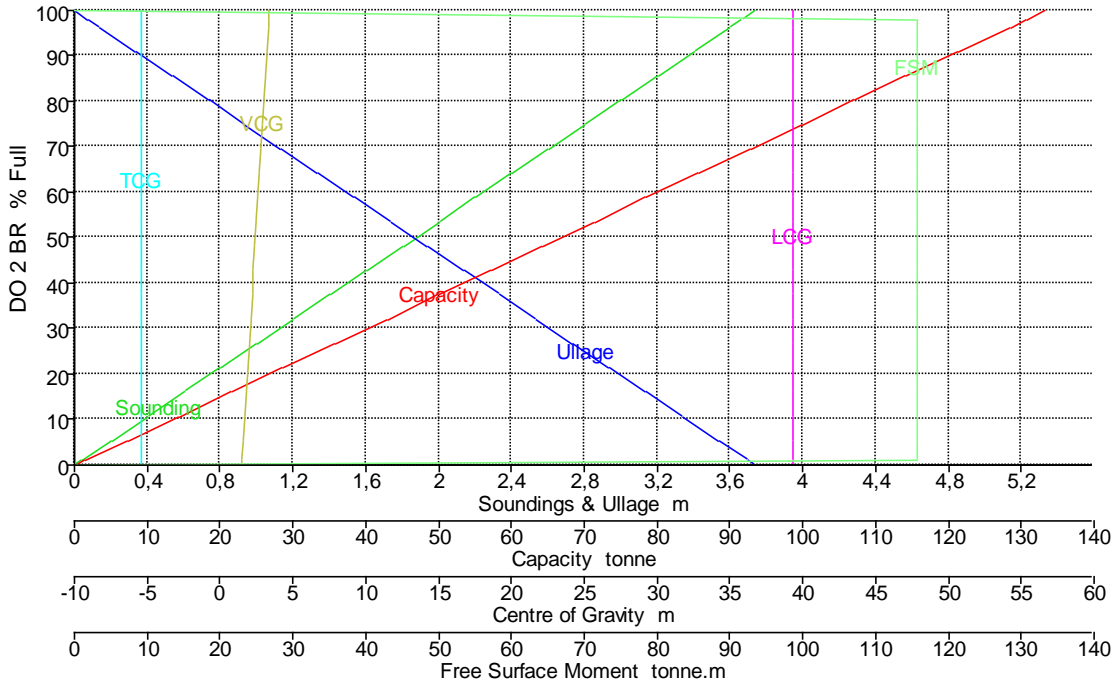

| Tank Name | Sounding m | Ullage m | % Full  | Capacity m <sup>3</sup> | Capacity tonne | LCG m  | TCG m  | VCG m | FSM tonne.m |
|-----------|------------|----------|---------|-------------------------|----------------|--------|--------|-------|-------------|
| DO 2 BR   | 3,740      | 0,000    | 100,000 | 158,696                 | 133,304        | 39,300 | -5,420 | 3,370 | 0,000       |
|           | 3,665      | 0,075    | 98,000  | 155,522                 | 130,638        | 39,300 | -5,420 | 3,333 | 115,654     |
|           | 3,661      | 0,079    | 97,900  | 155,363                 | 130,505        | 39,300 | -5,420 | 3,331 | 115,654     |
|           | 3,600      | 0,140    | 96,257  | 152,755                 | 128,314        | 39,300 | -5,420 | 3,300 | 115,654     |
|           | 3,400      | 0,340    | 90,909  | 144,269                 | 121,186        | 39,300 | -5,420 | 3,200 | 115,654     |
|           | 3,200      | 0,540    | 85,561  | 135,782                 | 114,057        | 39,300 | -5,420 | 3,100 | 115,654     |
|           | 3,000      | 0,740    | 80,214  | 127,296                 | 106,929        | 39,300 | -5,420 | 3,000 | 115,654     |
|           | 2,800      | 0,940    | 74,866  | 118,810                 | 99,800         | 39,300 | -5,420 | 2,900 | 115,654     |
|           | 2,600      | 1,140    | 69,519  | 110,323                 | 92,671         | 39,300 | -5,420 | 2,800 | 115,654     |
|           | 2,400      | 1,340    | 64,171  | 101,837                 | 85,543         | 39,300 | -5,420 | 2,700 | 115,654     |
|           | 2,200      | 1,540    | 58,824  | 93,350                  | 78,414         | 39,300 | -5,420 | 2,600 | 115,654     |
|           | 2,000      | 1,740    | 53,476  | 84,864                  | 71,286         | 39,300 | -5,420 | 2,500 | 115,654     |
|           | 1,800      | 1,940    | 48,128  | 76,378                  | 64,157         | 39,300 | -5,420 | 2,400 | 115,654     |
|           | 1,600      | 2,140    | 42,781  | 67,891                  | 57,029         | 39,300 | -5,420 | 2,300 | 115,654     |
|           | 1,400      | 2,340    | 37,433  | 59,405                  | 49,900         | 39,300 | -5,420 | 2,200 | 115,654     |
|           | 1,200      | 2,540    | 32,086  | 50,918                  | 42,771         | 39,300 | -5,420 | 2,100 | 115,654     |
|           | 1,000      | 2,740    | 26,738  | 42,432                  | 35,643         | 39,300 | -5,420 | 2,000 | 115,654     |
|           | 0,800      | 2,940    | 21,390  | 33,946                  | 28,514         | 39,300 | -5,420 | 1,900 | 115,654     |
|           | 0,600      | 3,140    | 16,043  | 25,459                  | 21,386         | 39,300 | -5,420 | 1,800 | 115,654     |
|           | 0,400      | 3,340    | 10,695  | 16,973                  | 14,257         | 39,300 | -5,420 | 1,700 | 115,654     |
|           | 0,200      | 3,540    | 5,348   | 8,486                   | 7,129          | 39,300 | -5,420 | 1,600 | 115,654     |
|           | 0,037      | 3,703    | 1,000   | 1,587                   | 1,333          | 39,300 | -5,420 | 1,519 | 115,654     |
|           | 0,000      | 3,740    | 0,000   | 0,000                   | 0,000          | 39,300 | -5,420 | 1,500 | 0,000       |

**Tank Calibrations - DO 2 ER**

Fluid Type = Diesel      Specific gravity = 0,84  
 Permeability = 100 %  
 Trim = 0 m (+ve by stern); Heel = 0 deg to starboard

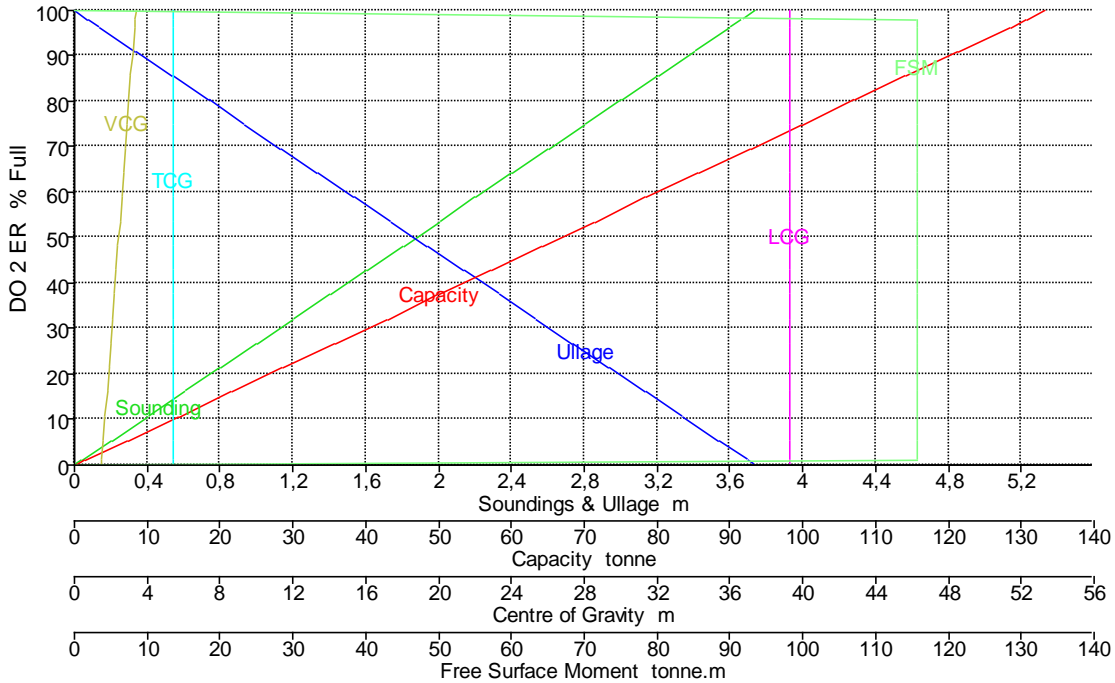

| Tank Name | Sounding m | Ullage m | % Full  | Capacity m <sup>3</sup> | Capacity tonne | LCG m  | TCG m | VCG m | FSM tonne.m |
|-----------|------------|----------|---------|-------------------------|----------------|--------|-------|-------|-------------|
| DO 2 ER   | 3,740      | 0,000    | 100,000 | 158,696                 | 133,304        | 39,300 | 5,420 | 3,370 | 0,000       |
|           | 3,665      | 0,075    | 98,000  | 155,522                 | 130,638        | 39,300 | 5,420 | 3,333 | 115,654     |
|           | 3,661      | 0,079    | 97,900  | 155,363                 | 130,505        | 39,300 | 5,420 | 3,331 | 115,654     |
|           | 3,600      | 0,140    | 96,257  | 152,755                 | 128,314        | 39,300 | 5,420 | 3,300 | 115,654     |
|           | 3,400      | 0,340    | 90,909  | 144,269                 | 121,186        | 39,300 | 5,420 | 3,200 | 115,654     |
|           | 3,200      | 0,540    | 85,561  | 135,782                 | 114,057        | 39,300 | 5,420 | 3,100 | 115,654     |
|           | 3,000      | 0,740    | 80,214  | 127,296                 | 106,929        | 39,300 | 5,420 | 3,000 | 115,654     |
|           | 2,800      | 0,940    | 74,866  | 118,810                 | 99,800         | 39,300 | 5,420 | 2,900 | 115,654     |
|           | 2,600      | 1,140    | 69,519  | 110,323                 | 92,671         | 39,300 | 5,420 | 2,800 | 115,654     |
|           | 2,400      | 1,340    | 64,171  | 101,837                 | 85,543         | 39,300 | 5,420 | 2,700 | 115,654     |
|           | 2,200      | 1,540    | 58,824  | 93,350                  | 78,414         | 39,300 | 5,420 | 2,600 | 115,654     |
|           | 2,000      | 1,740    | 53,476  | 84,864                  | 71,286         | 39,300 | 5,420 | 2,500 | 115,654     |
|           | 1,800      | 1,940    | 48,128  | 76,378                  | 64,157         | 39,300 | 5,420 | 2,400 | 115,654     |
|           | 1,600      | 2,140    | 42,781  | 67,891                  | 57,029         | 39,300 | 5,420 | 2,300 | 115,654     |
|           | 1,400      | 2,340    | 37,433  | 59,405                  | 49,900         | 39,300 | 5,420 | 2,200 | 115,654     |
|           | 1,200      | 2,540    | 32,086  | 50,918                  | 42,771         | 39,300 | 5,420 | 2,100 | 115,654     |
|           | 1,000      | 2,740    | 26,738  | 42,432                  | 35,643         | 39,300 | 5,420 | 2,000 | 115,654     |
|           | 0,800      | 2,940    | 21,390  | 33,946                  | 28,514         | 39,300 | 5,420 | 1,900 | 115,654     |
|           | 0,600      | 3,140    | 16,043  | 25,459                  | 21,386         | 39,300 | 5,420 | 1,800 | 115,654     |
|           | 0,400      | 3,340    | 10,695  | 16,973                  | 14,257         | 39,300 | 5,420 | 1,700 | 115,654     |
|           | 0,200      | 3,540    | 5,348   | 8,486                   | 7,129          | 39,300 | 5,420 | 1,600 | 115,654     |
|           | 0,037      | 3,703    | 1,000   | 1,587                   | 1,333          | 39,300 | 5,420 | 1,519 | 115,654     |
|           | 0,000      | 3,740    | 0,000   | 0,000                   | 0,000          | 39,300 | 5,420 | 1,500 | 0,000       |

**Tank Calibrations - DO 3 BR**

Fluid Type = Diesel      Specific gravity = 0,84  
 Permeability = 100 %  
 Trim = 0 m (+ve by stern); Heel = 0 deg to starboard

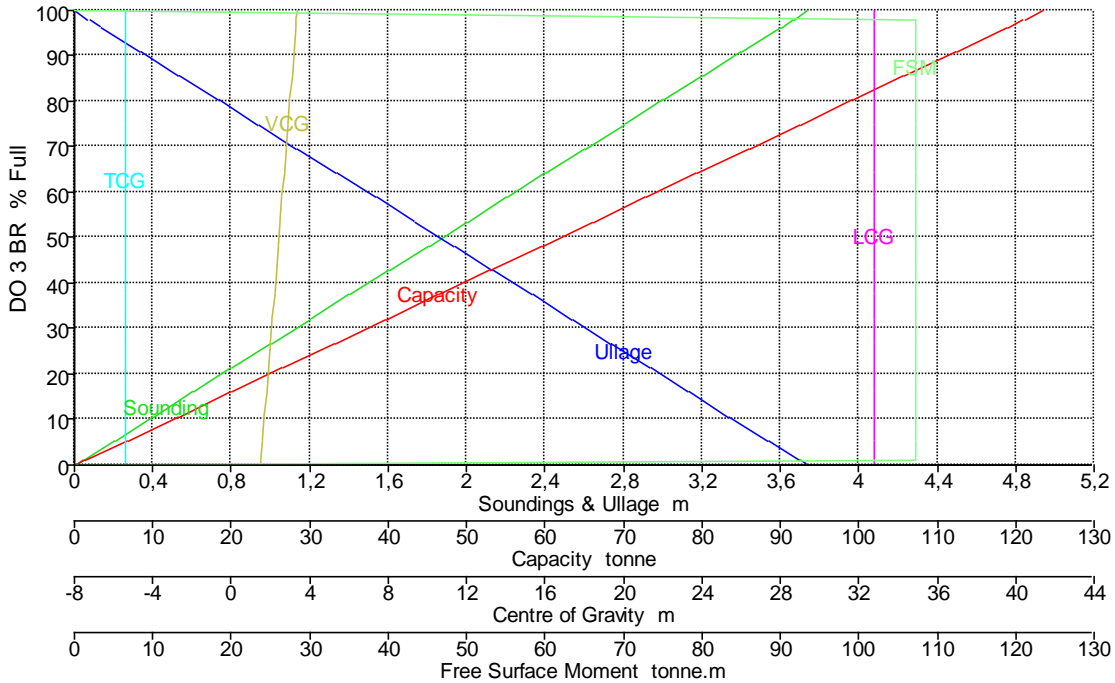

| Tank Name | Sounding m | Ullage m | % Full  | Capacity m <sup>3</sup> | Capacity tonne | LCG m  | TCG m  | VCG m | FSM tonne.m |
|-----------|------------|----------|---------|-------------------------|----------------|--------|--------|-------|-------------|
| DO 3 BR   | 3,740      | 0,000    | 100,000 | 147,027                 | 123,503        | 32,750 | -5,420 | 3,370 | 0,000       |
|           | 3,665      | 0,075    | 98,000  | 144,086                 | 121,033        | 32,750 | -5,420 | 3,333 | 107,150     |
|           | 3,661      | 0,079    | 97,900  | 143,939                 | 120,909        | 32,750 | -5,420 | 3,331 | 107,150     |
|           | 3,600      | 0,140    | 96,257  | 141,523                 | 118,879        | 32,750 | -5,420 | 3,300 | 107,150     |
|           | 3,400      | 0,340    | 90,909  | 133,661                 | 112,275        | 32,750 | -5,420 | 3,200 | 107,150     |
|           | 3,200      | 0,540    | 85,561  | 125,798                 | 105,671        | 32,750 | -5,420 | 3,100 | 107,150     |
|           | 3,000      | 0,740    | 80,214  | 117,936                 | 99,066         | 32,750 | -5,420 | 3,000 | 107,150     |
|           | 2,800      | 0,940    | 74,866  | 110,074                 | 92,462         | 32,750 | -5,420 | 2,900 | 107,150     |
|           | 2,600      | 1,140    | 69,519  | 102,211                 | 85,857         | 32,750 | -5,420 | 2,800 | 107,150     |
|           | 2,400      | 1,340    | 64,171  | 94,349                  | 79,253         | 32,750 | -5,420 | 2,700 | 107,150     |
|           | 2,200      | 1,540    | 58,824  | 86,486                  | 72,649         | 32,750 | -5,420 | 2,600 | 107,150     |
|           | 2,000      | 1,740    | 53,476  | 78,624                  | 66,044         | 32,750 | -5,420 | 2,500 | 107,150     |
|           | 1,800      | 1,940    | 48,128  | 70,762                  | 59,440         | 32,750 | -5,420 | 2,400 | 107,150     |
|           | 1,600      | 2,140    | 42,781  | 62,899                  | 52,835         | 32,750 | -5,420 | 2,300 | 107,150     |
|           | 1,400      | 2,340    | 37,433  | 55,037                  | 46,231         | 32,750 | -5,420 | 2,200 | 107,150     |
|           | 1,200      | 2,540    | 32,086  | 47,174                  | 39,626         | 32,750 | -5,420 | 2,100 | 107,150     |
|           | 1,000      | 2,740    | 26,738  | 39,312                  | 33,022         | 32,750 | -5,420 | 2,000 | 107,150     |
|           | 0,800      | 2,940    | 21,390  | 31,450                  | 26,418         | 32,750 | -5,420 | 1,900 | 107,150     |
|           | 0,600      | 3,140    | 16,043  | 23,587                  | 19,813         | 32,750 | -5,420 | 1,800 | 107,150     |
|           | 0,400      | 3,340    | 10,695  | 15,725                  | 13,209         | 32,750 | -5,420 | 1,700 | 107,150     |
|           | 0,200      | 3,540    | 5,348   | 7,862                   | 6,604          | 32,750 | -5,420 | 1,600 | 107,150     |
|           | 0,037      | 3,703    | 1,000   | 1,470                   | 1,235          | 32,750 | -5,420 | 1,519 | 107,150     |
|           | 0,000      | 3,740    | 0,000   | 0,000                   | 0,000          | 32,750 | -5,420 | 1,500 | 0,000       |

**Tank Calibrations - DO 3 ER**

Fluid Type = Diesel    Specific gravity = 0,84  
 Permeability = 100 %  
 Trim = 0 m (+ve by stern); Heel = 0 deg to starboard

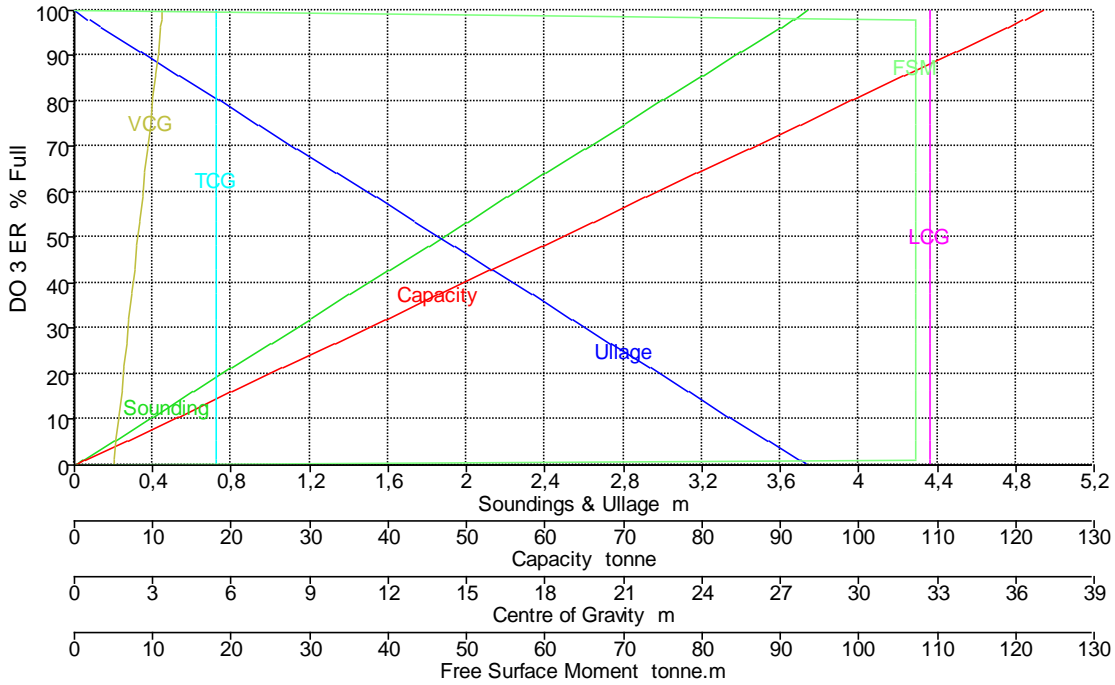

| Tank Name | Sounding m | Ullage m | % Full  | Capacity m <sup>3</sup> | Capacity tonne | LCG m  | TCG m | VCG m | FSM tonne.m |
|-----------|------------|----------|---------|-------------------------|----------------|--------|-------|-------|-------------|
| DO 3 ER   | 3,740      | 0,000    | 100,000 | 147,027                 | 123,503        | 32,750 | 5,420 | 3,370 | 0,000       |
|           | 3,665      | 0,075    | 98,000  | 144,086                 | 121,033        | 32,750 | 5,420 | 3,333 | 107,150     |
|           | 3,661      | 0,079    | 97,900  | 143,939                 | 120,909        | 32,750 | 5,420 | 3,331 | 107,150     |
|           | 3,600      | 0,140    | 96,257  | 141,523                 | 118,879        | 32,750 | 5,420 | 3,300 | 107,150     |
|           | 3,400      | 0,340    | 90,909  | 133,661                 | 112,275        | 32,750 | 5,420 | 3,200 | 107,150     |
|           | 3,200      | 0,540    | 85,561  | 125,798                 | 105,671        | 32,750 | 5,420 | 3,100 | 107,150     |
|           | 3,000      | 0,740    | 80,214  | 117,936                 | 99,066         | 32,750 | 5,420 | 3,000 | 107,150     |
|           | 2,800      | 0,940    | 74,866  | 110,074                 | 92,462         | 32,750 | 5,420 | 2,900 | 107,150     |
|           | 2,600      | 1,140    | 69,519  | 102,211                 | 85,857         | 32,750 | 5,420 | 2,800 | 107,150     |
|           | 2,400      | 1,340    | 64,171  | 94,349                  | 79,253         | 32,750 | 5,420 | 2,700 | 107,150     |
|           | 2,200      | 1,540    | 58,824  | 86,486                  | 72,649         | 32,750 | 5,420 | 2,600 | 107,150     |
|           | 2,000      | 1,740    | 53,476  | 78,624                  | 66,044         | 32,750 | 5,420 | 2,500 | 107,150     |
|           | 1,800      | 1,940    | 48,128  | 70,762                  | 59,440         | 32,750 | 5,420 | 2,400 | 107,150     |
|           | 1,600      | 2,140    | 42,781  | 62,899                  | 52,835         | 32,750 | 5,420 | 2,300 | 107,150     |
|           | 1,400      | 2,340    | 37,433  | 55,037                  | 46,231         | 32,750 | 5,420 | 2,200 | 107,150     |
|           | 1,200      | 2,540    | 32,086  | 47,174                  | 39,626         | 32,750 | 5,420 | 2,100 | 107,150     |
|           | 1,000      | 2,740    | 26,738  | 39,312                  | 33,022         | 32,750 | 5,420 | 2,000 | 107,150     |
|           | 0,800      | 2,940    | 21,390  | 31,450                  | 26,418         | 32,750 | 5,420 | 1,900 | 107,150     |
|           | 0,600      | 3,140    | 16,043  | 23,587                  | 19,813         | 32,750 | 5,420 | 1,800 | 107,150     |
|           | 0,400      | 3,340    | 10,695  | 15,725                  | 13,209         | 32,750 | 5,420 | 1,700 | 107,150     |
|           | 0,200      | 3,540    | 5,348   | 7,862                   | 6,604          | 32,750 | 5,420 | 1,600 | 107,150     |
|           | 0,037      | 3,703    | 1,000   | 1,470                   | 1,235          | 32,750 | 5,420 | 1,519 | 107,150     |
|           | 0,000      | 3,740    | 0,000   | 0,000                   | 0,000          | 32,750 | 5,420 | 1,500 | 0,000       |

**Tank Calibrations - DO 4 BR**

Fluid Type = Diesel    Specific gravity = 0,84  
 Permeability = 100 %  
 Trim = 0 m (+ve by stern); Heel = 0 deg to starboard

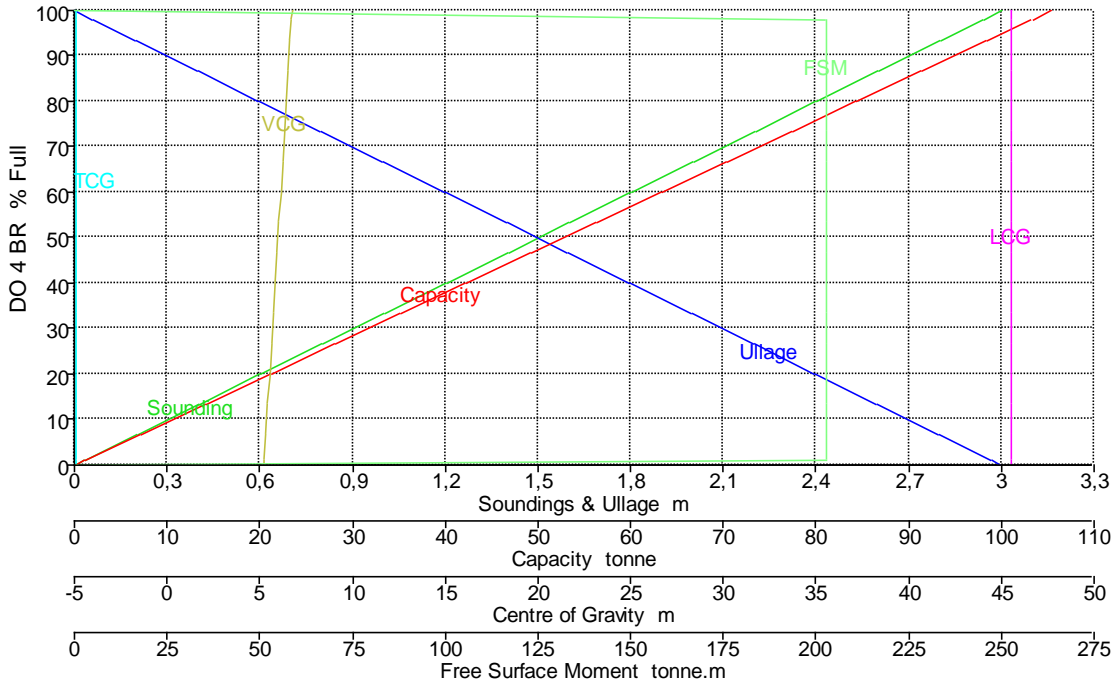

| Tank Name | Sounding m | Ullage m | % Full  | Capacity m <sup>3</sup> | Capacity tonne | LCG m  | TCG m  | VCG m | FSM tonne.m |
|-----------|------------|----------|---------|-------------------------|----------------|--------|--------|-------|-------------|
| DO 4 BR   | 3,000      | 0,000    | 100,000 | 125,433                 | 105,363        | 45,540 | -4,900 | 6,740 | 0,000       |
|           | 2,940      | 0,060    | 98,000  | 122,924                 | 103,256        | 45,540 | -4,900 | 6,710 | 202,622     |
|           | 2,937      | 0,063    | 97,900  | 122,798                 | 103,151        | 45,540 | -4,900 | 6,708 | 202,622     |
|           | 2,800      | 0,200    | 93,334  | 117,071                 | 98,339         | 45,540 | -4,900 | 6,640 | 202,622     |
|           | 2,600      | 0,400    | 86,667  | 108,709                 | 91,315         | 45,540 | -4,900 | 6,540 | 202,622     |
|           | 2,400      | 0,600    | 80,000  | 100,346                 | 84,291         | 45,540 | -4,900 | 6,440 | 202,622     |
|           | 2,200      | 0,800    | 73,334  | 91,984                  | 77,267         | 45,540 | -4,900 | 6,340 | 202,622     |
|           | 2,000      | 1,000    | 66,667  | 83,622                  | 70,242         | 45,540 | -4,900 | 6,240 | 202,622     |
|           | 1,800      | 1,200    | 60,000  | 75,260                  | 63,218         | 45,540 | -4,900 | 6,140 | 202,622     |
|           | 1,600      | 1,400    | 53,334  | 66,898                  | 56,194         | 45,540 | -4,900 | 6,040 | 202,622     |
|           | 1,400      | 1,600    | 46,667  | 58,535                  | 49,170         | 45,540 | -4,900 | 5,940 | 202,622     |
|           | 1,200      | 1,800    | 40,000  | 50,173                  | 42,145         | 45,540 | -4,900 | 5,840 | 202,622     |
|           | 1,000      | 2,000    | 33,333  | 41,811                  | 35,121         | 45,540 | -4,900 | 5,740 | 202,622     |
|           | 0,800      | 2,200    | 26,667  | 33,449                  | 28,097         | 45,540 | -4,900 | 5,640 | 202,622     |
|           | 0,600      | 2,400    | 20,000  | 25,087                  | 21,073         | 45,540 | -4,900 | 5,540 | 202,622     |
|           | 0,400      | 2,600    | 13,333  | 16,724                  | 14,048         | 45,540 | -4,900 | 5,440 | 202,622     |
|           | 0,200      | 2,800    | 6,667   | 8,362                   | 7,024          | 45,540 | -4,900 | 5,340 | 202,622     |
|           | 0,030      | 2,970    | 1,000   | 1,254                   | 1,054          | 45,540 | -4,900 | 5,255 | 202,622     |
|           | 0,000      | 3,000    | 0,000   | 0,000                   | 0,000          | 45,540 | -4,900 | 5,240 | 0,000       |

### Tank Calibrations - DO 4 ER

Fluid Type = Diesel    Specific gravity = 0,84  
 Permeability = 100 %  
 Trim = 0 m (+ve by stern); Heel = 0 deg to starboard

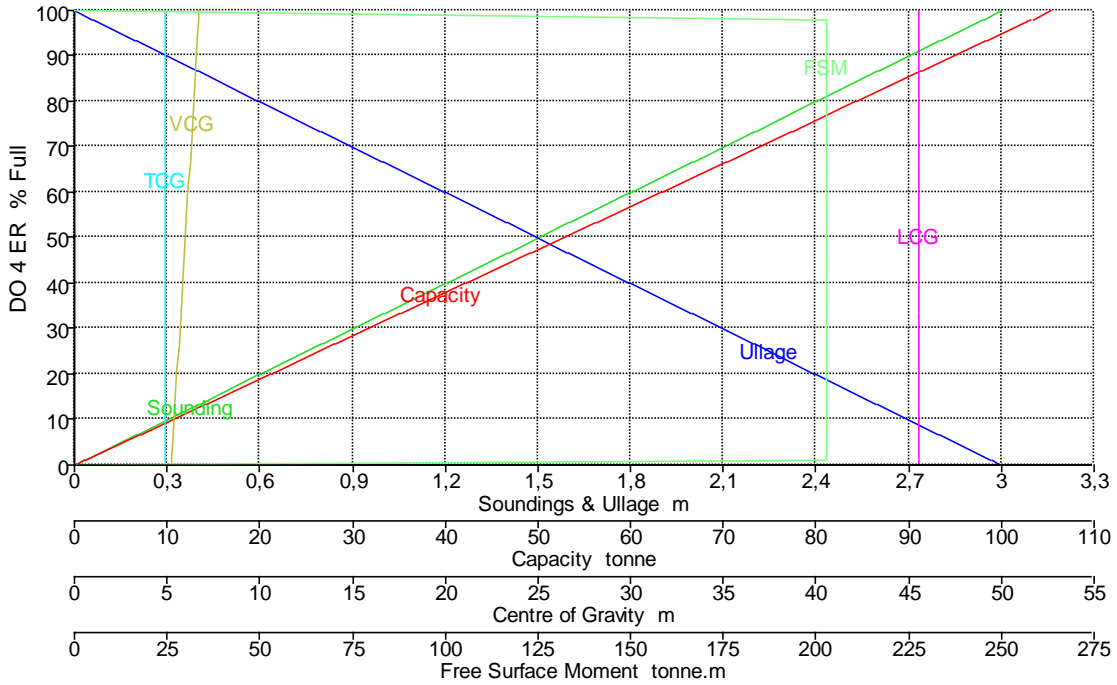

| Tank Name | Sounding m | Ullage m | % Full  | Capacity m <sup>3</sup> | Capacity tonne | LCG m  | TCG m | VCG m | FSM tonne.m |
|-----------|------------|----------|---------|-------------------------|----------------|--------|-------|-------|-------------|
| DO 4 ER   | 3,000      | 0,000    | 100,000 | 125,433                 | 105,363        | 45,540 | 4,900 | 6,740 | 0,000       |
|           | 2,940      | 0,060    | 98,000  | 122,924                 | 103,256        | 45,540 | 4,900 | 6,710 | 202,622     |
|           | 2,937      | 0,063    | 97,900  | 122,798                 | 103,151        | 45,540 | 4,900 | 6,708 | 202,622     |
|           | 2,800      | 0,200    | 93,334  | 117,071                 | 98,339         | 45,540 | 4,900 | 6,640 | 202,622     |
|           | 2,600      | 0,400    | 86,667  | 108,709                 | 91,315         | 45,540 | 4,900 | 6,540 | 202,622     |
|           | 2,400      | 0,600    | 80,000  | 100,346                 | 84,291         | 45,540 | 4,900 | 6,440 | 202,622     |
|           | 2,200      | 0,800    | 73,334  | 91,984                  | 77,267         | 45,540 | 4,900 | 6,340 | 202,622     |
|           | 2,000      | 1,000    | 66,667  | 83,622                  | 70,242         | 45,540 | 4,900 | 6,240 | 202,622     |
|           | 1,800      | 1,200    | 60,000  | 75,260                  | 63,218         | 45,540 | 4,900 | 6,140 | 202,622     |
|           | 1,600      | 1,400    | 53,334  | 66,898                  | 56,194         | 45,540 | 4,900 | 6,040 | 202,622     |
|           | 1,400      | 1,600    | 46,667  | 58,535                  | 49,170         | 45,540 | 4,900 | 5,940 | 202,622     |
|           | 1,200      | 1,800    | 40,000  | 50,173                  | 42,145         | 45,540 | 4,900 | 5,840 | 202,622     |
|           | 1,000      | 2,000    | 33,333  | 41,811                  | 35,121         | 45,540 | 4,900 | 5,740 | 202,622     |
|           | 0,800      | 2,200    | 26,667  | 33,449                  | 28,097         | 45,540 | 4,900 | 5,640 | 202,622     |
|           | 0,600      | 2,400    | 20,000  | 25,087                  | 21,073         | 45,540 | 4,900 | 5,540 | 202,622     |
|           | 0,400      | 2,600    | 13,333  | 16,724                  | 14,048         | 45,540 | 4,900 | 5,440 | 202,622     |
|           | 0,200      | 2,800    | 6,667   | 8,362                   | 7,024          | 45,540 | 4,900 | 5,340 | 202,622     |
|           | 0,030      | 2,970    | 1,000   | 1,254                   | 1,054          | 45,540 | 4,900 | 5,255 | 202,622     |
|           | 0,000      | 3,000    | 0,000   | 0,000                   | 0,000          | 45,540 | 4,900 | 5,240 | 0,000       |

### Tank Calibrations - DO SER 1

Fluid Type = Diesel    Specific gravity = 0,84  
 Permeability = 100 %  
 Trim = 0 m (+ve by stern); Heel = 0 deg to starboard

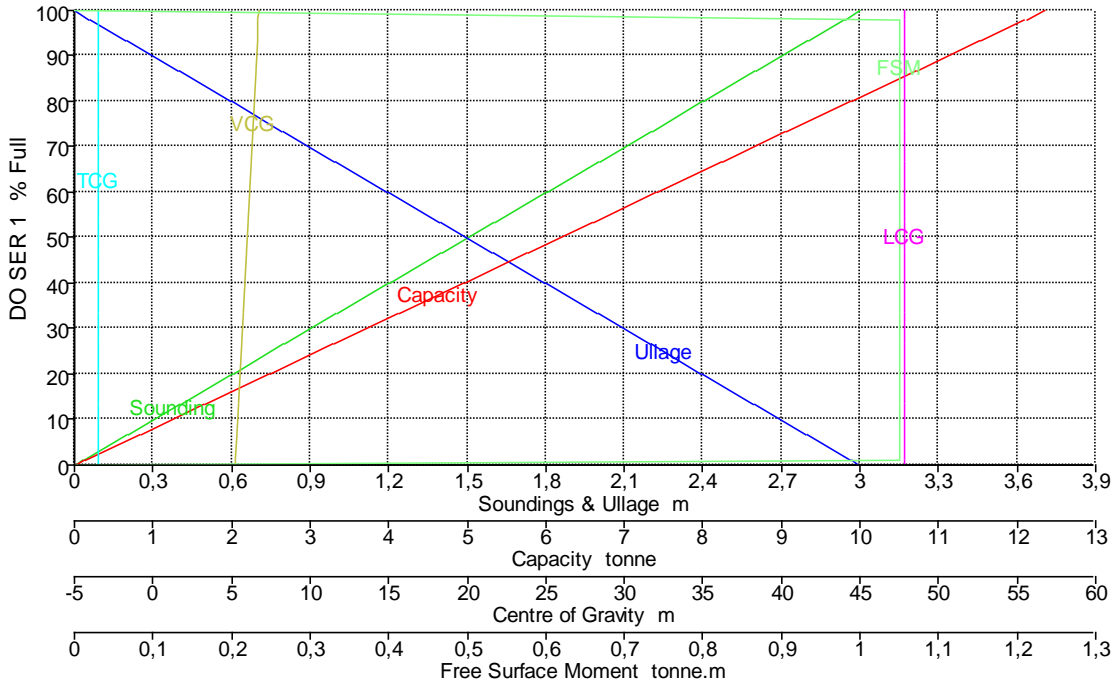

| Tank Name | Sounding m | Ullage m | % Full  | Capacity m <sup>3</sup> | Capacity tonne | LCG m  | TCG m  | VCG m | FSM tonne.m |
|-----------|------------|----------|---------|-------------------------|----------------|--------|--------|-------|-------------|
| DO SER 1  | 3,000      | 0,000    | 100,000 | 14,700                  | 12,348         | 47,800 | -3,475 | 6,740 | 0,000       |
|           | 2,940      | 0,060    | 98,000  | 14,406                  | 12,101         | 47,800 | -3,475 | 6,710 | 1,050       |
|           | 2,937      | 0,063    | 97,900  | 14,391                  | 12,089         | 47,800 | -3,475 | 6,708 | 1,050       |
|           | 2,800      | 0,200    | 93,334  | 13,720                  | 11,525         | 47,800 | -3,475 | 6,640 | 1,050       |
|           | 2,600      | 0,400    | 86,667  | 12,740                  | 10,702         | 47,800 | -3,475 | 6,540 | 1,050       |
|           | 2,400      | 0,600    | 80,000  | 11,760                  | 9,878          | 47,800 | -3,475 | 6,440 | 1,050       |
|           | 2,200      | 0,800    | 73,334  | 10,780                  | 9,055          | 47,800 | -3,475 | 6,340 | 1,050       |
|           | 2,000      | 1,000    | 66,667  | 9,800                   | 8,232          | 47,800 | -3,475 | 6,240 | 1,050       |
|           | 1,800      | 1,200    | 60,000  | 8,820                   | 7,409          | 47,800 | -3,475 | 6,140 | 1,050       |
|           | 1,600      | 1,400    | 53,334  | 7,840                   | 6,586          | 47,800 | -3,475 | 6,040 | 1,050       |
|           | 1,400      | 1,600    | 46,667  | 6,860                   | 5,762          | 47,800 | -3,475 | 5,940 | 1,050       |
|           | 1,200      | 1,800    | 40,000  | 5,880                   | 4,939          | 47,800 | -3,475 | 5,840 | 1,050       |
|           | 1,000      | 2,000    | 33,334  | 4,900                   | 4,116          | 47,800 | -3,475 | 5,740 | 1,050       |
|           | 0,800      | 2,200    | 26,667  | 3,920                   | 3,293          | 47,800 | -3,475 | 5,640 | 1,050       |
|           | 0,600      | 2,400    | 20,000  | 2,940                   | 2,470          | 47,800 | -3,475 | 5,540 | 1,050       |
|           | 0,400      | 2,600    | 13,333  | 1,960                   | 1,646          | 47,800 | -3,475 | 5,440 | 1,050       |
|           | 0,200      | 2,800    | 6,667   | 0,980                   | 0,823          | 47,800 | -3,475 | 5,340 | 1,050       |
|           | 0,030      | 2,970    | 1,000   | 0,147                   | 0,123          | 47,800 | -3,475 | 5,255 | 1,050       |
|           | 0,000      | 3,000    | 0,000   | 0,000                   | 0,000          | 47,800 | -3,475 | 5,240 | 0,000       |

### Tank Calibrations - DO SED

Fluid Type = Diesel    Specific gravity = 0,84  
 Permeability = 100 %  
 Trim = 0 m (+ve by stern); Heel = 0 deg to starboard

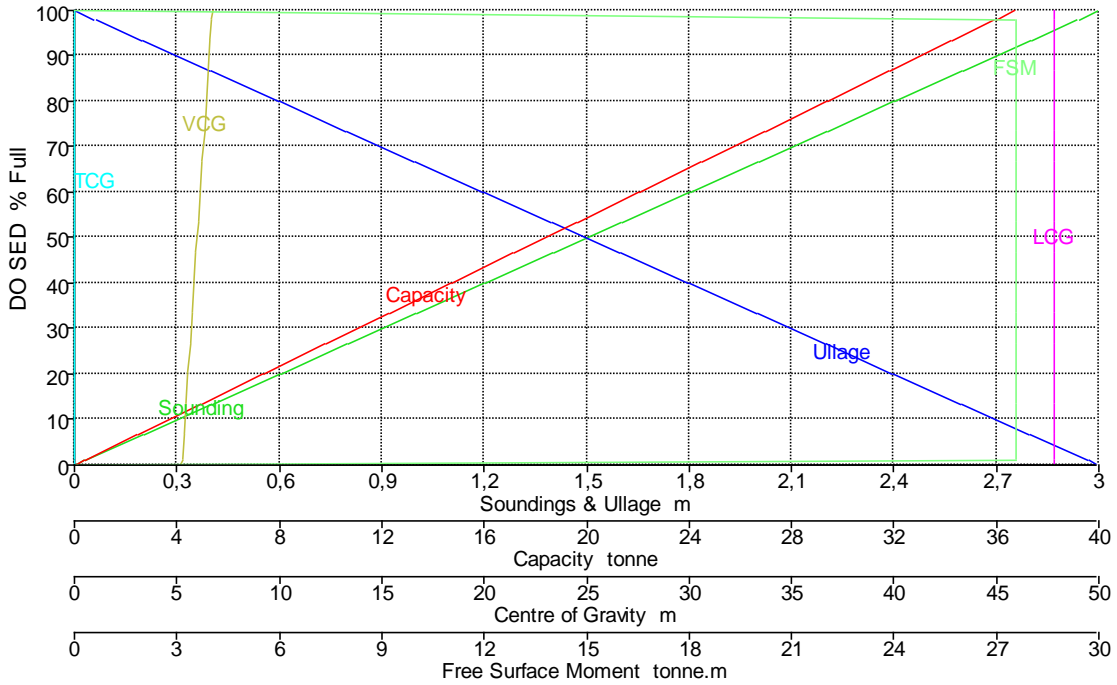

| Tank Name | Sounding m | Ullage m | % Full  | Capacity m <sup>3</sup> | Capacity tonne | LCG m  | TCG m | VCG m | FSM tonne.m |
|-----------|------------|----------|---------|-------------------------|----------------|--------|-------|-------|-------------|
| DO SED    | 3,000      | 0,000    | 100,000 | 43,680                  | 36,691         | 47,800 | 0,000 | 6,740 | 0,000       |
|           | 2,940      | 0,060    | 98,000  | 42,806                  | 35,957         | 47,800 | 0,000 | 6,710 | 27,559      |
|           | 2,937      | 0,063    | 97,900  | 42,762                  | 35,920         | 47,800 | 0,000 | 6,708 | 27,559      |
|           | 2,800      | 0,200    | 93,334  | 40,768                  | 34,245         | 47,800 | 0,000 | 6,640 | 27,559      |
|           | 2,600      | 0,400    | 86,667  | 37,856                  | 31,799         | 47,800 | 0,000 | 6,540 | 27,559      |
|           | 2,400      | 0,600    | 80,000  | 34,944                  | 29,353         | 47,800 | 0,000 | 6,440 | 27,559      |
|           | 2,200      | 0,800    | 73,334  | 32,032                  | 26,907         | 47,800 | 0,000 | 6,340 | 27,559      |
|           | 2,000      | 1,000    | 66,667  | 29,120                  | 24,461         | 47,800 | 0,000 | 6,240 | 27,559      |
|           | 1,800      | 1,200    | 60,000  | 26,208                  | 22,015         | 47,800 | 0,000 | 6,140 | 27,559      |
|           | 1,600      | 1,400    | 53,334  | 23,296                  | 19,569         | 47,800 | 0,000 | 6,040 | 27,559      |
|           | 1,400      | 1,600    | 46,667  | 20,384                  | 17,123         | 47,800 | 0,000 | 5,940 | 27,559      |
|           | 1,200      | 1,800    | 40,000  | 17,472                  | 14,676         | 47,800 | 0,000 | 5,840 | 27,559      |
|           | 1,000      | 2,000    | 33,334  | 14,560                  | 12,230         | 47,800 | 0,000 | 5,740 | 27,559      |
|           | 0,800      | 2,200    | 26,667  | 11,648                  | 9,784          | 47,800 | 0,000 | 5,640 | 27,559      |
|           | 0,600      | 2,400    | 20,000  | 8,736                   | 7,338          | 47,800 | 0,000 | 5,540 | 27,559      |
|           | 0,400      | 2,600    | 13,333  | 5,824                   | 4,892          | 47,800 | 0,000 | 5,440 | 27,559      |
|           | 0,200      | 2,800    | 6,667   | 2,912                   | 2,446          | 47,800 | 0,000 | 5,340 | 27,559      |
|           | 0,030      | 2,970    | 1,000   | 0,437                   | 0,367          | 47,800 | 0,000 | 5,255 | 27,559      |
|           | 0,000      | 3,000    | 0,000   | 0,000                   | 0,000          | 47,800 | 0,000 | 5,240 | 0,000       |

### Tank Calibrations - DO SER 2

Fluid Type = Diesel    Specific gravity = 0,84  
 Permeability = 100 %  
 Trim = 0 m (+ve by stern); Heel = 0 deg to starboard



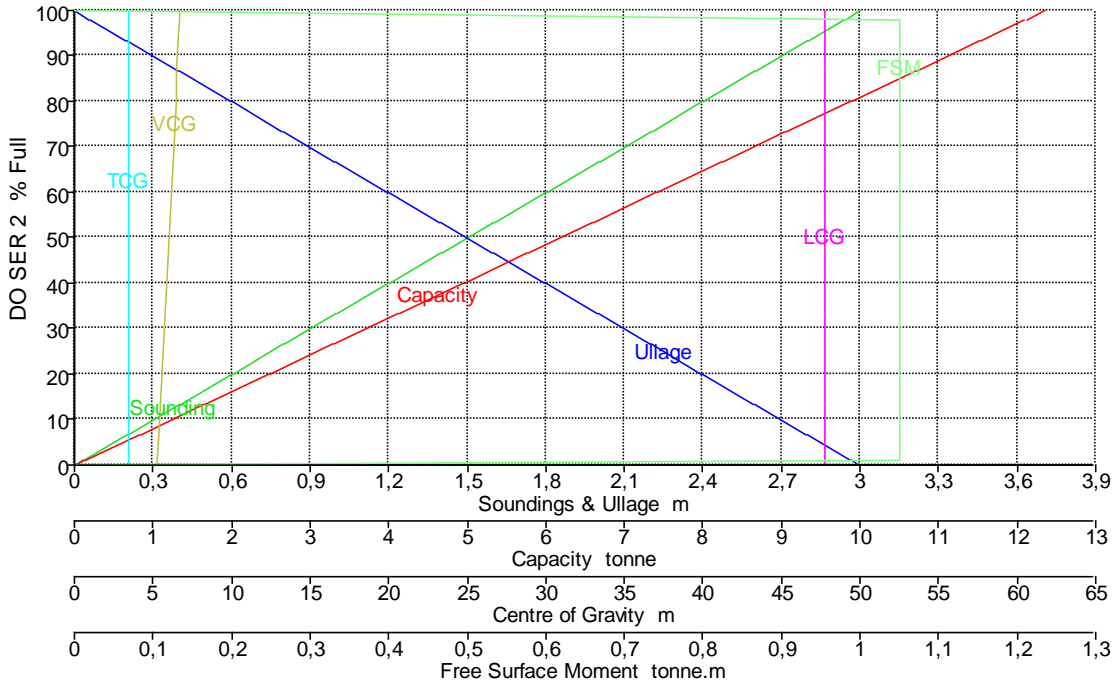

| Tank Name | Sounding m | Ullage m | % Full  | Capacity m <sup>3</sup> | Capacity tonne | LCG m  | TCG m | VCG m | FSM tonne.m |
|-----------|------------|----------|---------|-------------------------|----------------|--------|-------|-------|-------------|
| DO SER 2  | 3,000      | 0,000    | 100,000 | 14,700                  | 12,348         | 47,800 | 3,475 | 6,740 | 0,000       |
|           | 2,940      | 0,060    | 98,000  | 14,406                  | 12,101         | 47,800 | 3,475 | 6,710 | 1,050       |
|           | 2,937      | 0,063    | 97,900  | 14,391                  | 12,089         | 47,800 | 3,475 | 6,708 | 1,050       |
|           | 2,800      | 0,200    | 93,334  | 13,720                  | 11,525         | 47,800 | 3,475 | 6,640 | 1,050       |
|           | 2,600      | 0,400    | 86,667  | 12,740                  | 10,702         | 47,800 | 3,475 | 6,540 | 1,050       |
|           | 2,400      | 0,600    | 80,000  | 11,760                  | 9,878          | 47,800 | 3,475 | 6,440 | 1,050       |
|           | 2,200      | 0,800    | 73,334  | 10,780                  | 9,055          | 47,800 | 3,475 | 6,340 | 1,050       |
|           | 2,000      | 1,000    | 66,667  | 9,800                   | 8,232          | 47,800 | 3,475 | 6,240 | 1,050       |
|           | 1,800      | 1,200    | 60,000  | 8,820                   | 7,409          | 47,800 | 3,475 | 6,140 | 1,050       |
|           | 1,600      | 1,400    | 53,334  | 7,840                   | 6,586          | 47,800 | 3,475 | 6,040 | 1,050       |
|           | 1,400      | 1,600    | 46,667  | 6,860                   | 5,762          | 47,800 | 3,475 | 5,940 | 1,050       |
|           | 1,200      | 1,800    | 40,000  | 5,880                   | 4,939          | 47,800 | 3,475 | 5,840 | 1,050       |
|           | 1,000      | 2,000    | 33,334  | 4,900                   | 4,116          | 47,800 | 3,475 | 5,740 | 1,050       |
|           | 0,800      | 2,200    | 26,667  | 3,920                   | 3,293          | 47,800 | 3,475 | 5,640 | 1,050       |
|           | 0,600      | 2,400    | 20,000  | 2,940                   | 2,470          | 47,800 | 3,475 | 5,540 | 1,050       |
|           | 0,400      | 2,600    | 13,333  | 1,960                   | 1,646          | 47,800 | 3,475 | 5,440 | 1,050       |
|           | 0,200      | 2,800    | 6,667   | 0,980                   | 0,823          | 47,800 | 3,475 | 5,340 | 1,050       |
|           | 0,030      | 2,970    | 1,000   | 0,147                   | 0,123          | 47,800 | 3,475 | 5,255 | 1,050       |
|           | 0,000      | 3,000    | 0,000   | 0,000                   | 0,000          | 47,800 | 3,475 | 5,240 | 0,000       |

### Tank Calibrations - LUB OIL

Fluid Type = Lube Oil      Specific gravity = 0,92  
 Permeability = 100 %  
 Trim = 0 m (+ve by stern); Heel = 0 deg to starboard

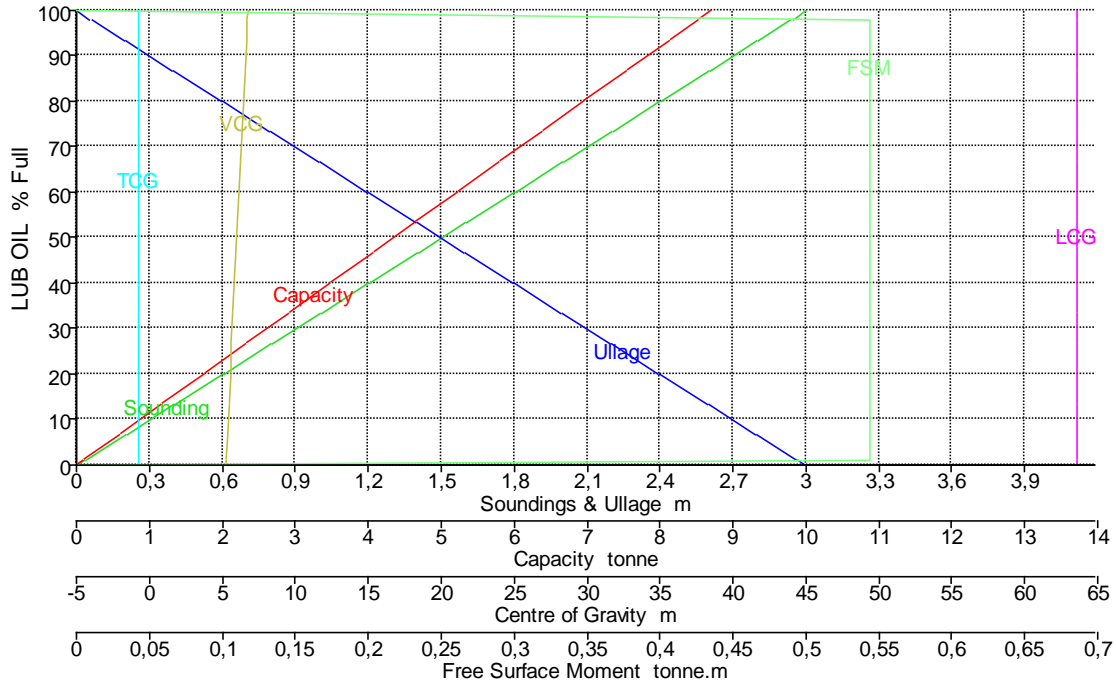

| Tank Name | Sounding m | Ullage m | % Full  | Capacity m <sup>3</sup> | Capacity tonne | LCG m  | TCG m  | VCG m | FSM tonne.m |
|-----------|------------|----------|---------|-------------------------|----------------|--------|--------|-------|-------------|
| LUB OIL   | 3,000      | 0,000    | 100,000 | 9,450                   | 8,694          | 63,550 | -0,750 | 6,740 | 0,000       |
|           | 2,940      | 0,060    | 98,000  | 9,261                   | 8,520          | 63,550 | -0,750 | 6,710 | 0,543       |
|           | 2,937      | 0,063    | 97,900  | 9,251                   | 8,511          | 63,550 | -0,750 | 6,708 | 0,543       |
|           | 2,800      | 0,200    | 93,338  | 8,820                   | 8,114          | 63,550 | -0,750 | 6,640 | 0,543       |
|           | 2,600      | 0,400    | 86,671  | 8,190                   | 7,535          | 63,550 | -0,750 | 6,540 | 0,543       |
|           | 2,400      | 0,600    | 80,004  | 7,560                   | 6,955          | 63,550 | -0,750 | 6,440 | 0,543       |
|           | 2,200      | 0,800    | 73,337  | 6,930                   | 6,376          | 63,550 | -0,750 | 6,340 | 0,543       |
|           | 2,000      | 1,000    | 66,670  | 6,300                   | 5,796          | 63,550 | -0,750 | 6,240 | 0,543       |
|           | 1,800      | 1,200    | 60,003  | 5,670                   | 5,216          | 63,550 | -0,750 | 6,140 | 0,543       |
|           | 1,600      | 1,400    | 53,336  | 5,040                   | 4,637          | 63,550 | -0,750 | 6,040 | 0,543       |
|           | 1,400      | 1,600    | 46,669  | 4,410                   | 4,057          | 63,550 | -0,750 | 5,940 | 0,543       |
|           | 1,200      | 1,800    | 40,002  | 3,780                   | 3,478          | 63,550 | -0,750 | 5,840 | 0,543       |
|           | 1,000      | 2,000    | 33,335  | 3,150                   | 2,898          | 63,550 | -0,750 | 5,740 | 0,543       |
|           | 0,800      | 2,200    | 26,668  | 2,520                   | 2,318          | 63,550 | -0,750 | 5,640 | 0,543       |
|           | 0,600      | 2,400    | 20,001  | 1,890                   | 1,739          | 63,550 | -0,750 | 5,540 | 0,543       |
|           | 0,400      | 2,600    | 13,334  | 1,260                   | 1,159          | 63,550 | -0,750 | 5,440 | 0,543       |
|           | 0,200      | 2,800    | 6,667   | 0,630                   | 0,580          | 63,550 | -0,750 | 5,340 | 0,543       |
|           | 0,030      | 2,970    | 1,000   | 0,094                   | 0,087          | 63,550 | -0,750 | 5,255 | 0,543       |
|           | 0,000      | 3,000    | 0,000   | 0,000                   | 0,000          | 63,550 | -0,750 | 5,240 | 0,000       |

**Tank Calibrations - USED OIL**

Fluid Type = Lube Oil      Specific gravity = 0,92  
 Permeability = 100 %  
 Trim = 0 m (+ve by stern); Heel = 0 deg to starboard

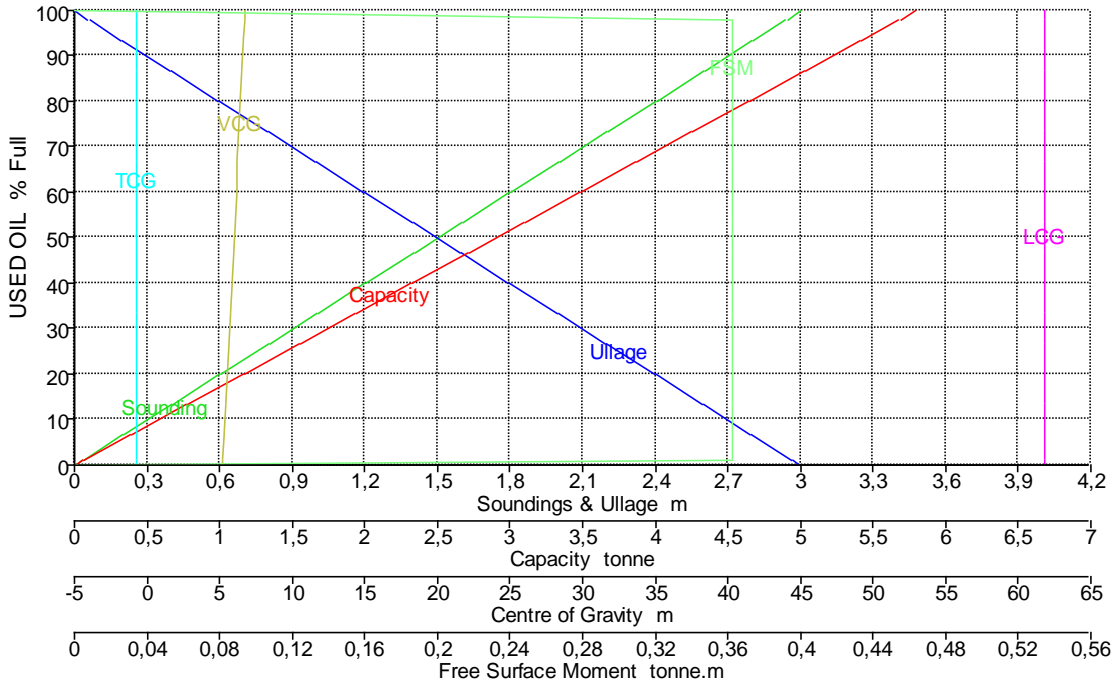

| Tank Name | Sounding m | Ullage m | % Full  | Capacity m <sup>3</sup> | Capacity tonne | LCG m  | TCG m  | VCG m | FSM tonne.m |
|-----------|------------|----------|---------|-------------------------|----------------|--------|--------|-------|-------------|
| USED OIL  | 3,000      | 0,000    | 100,000 | 6,300                   | 5,796          | 61,800 | -0,750 | 6,740 | 0,000       |
|           | 2,940      | 0,060    | 98,000  | 6,174                   | 5,680          | 61,800 | -0,750 | 6,710 | 0,362       |
|           | 2,937      | 0,063    | 97,900  | 6,167                   | 5,674          | 61,800 | -0,750 | 6,708 | 0,362       |
|           | 2,800      | 0,200    | 93,340  | 5,880                   | 5,410          | 61,800 | -0,750 | 6,640 | 0,362       |
|           | 2,600      | 0,400    | 86,673  | 5,460                   | 5,023          | 61,800 | -0,750 | 6,540 | 0,362       |
|           | 2,400      | 0,600    | 80,005  | 5,040                   | 4,637          | 61,800 | -0,750 | 6,440 | 0,362       |
|           | 2,200      | 0,800    | 73,338  | 4,620                   | 4,250          | 61,800 | -0,750 | 6,340 | 0,362       |
|           | 2,000      | 1,000    | 66,671  | 4,200                   | 3,864          | 61,800 | -0,750 | 6,240 | 0,362       |
|           | 1,800      | 1,200    | 60,004  | 3,780                   | 3,478          | 61,800 | -0,750 | 6,140 | 0,362       |
|           | 1,600      | 1,400    | 53,337  | 3,360                   | 3,091          | 61,800 | -0,750 | 6,040 | 0,362       |
|           | 1,400      | 1,600    | 46,670  | 2,940                   | 2,705          | 61,800 | -0,750 | 5,940 | 0,362       |
|           | 1,200      | 1,800    | 40,003  | 2,520                   | 2,318          | 61,800 | -0,750 | 5,840 | 0,362       |
|           | 1,000      | 2,000    | 33,336  | 2,100                   | 1,932          | 61,800 | -0,750 | 5,740 | 0,362       |
|           | 0,800      | 2,200    | 26,668  | 1,680                   | 1,546          | 61,800 | -0,750 | 5,640 | 0,362       |
|           | 0,600      | 2,400    | 20,001  | 1,260                   | 1,159          | 61,800 | -0,750 | 5,540 | 0,362       |
|           | 0,400      | 2,600    | 13,334  | 0,840                   | 0,773          | 61,800 | -0,750 | 5,440 | 0,362       |
|           | 0,200      | 2,800    | 6,667   | 0,420                   | 0,386          | 61,800 | -0,750 | 5,340 | 0,362       |
|           | 0,030      | 2,970    | 1,000   | 0,063                   | 0,058          | 61,800 | -0,750 | 5,255 | 0,362       |
|           | 0,000      | 3,000    | 0,000   | 0,000                   | 0,000          | 61,800 | -0,750 | 5,240 | 0,000       |

### Tank Calibrations - LODOS

Fluid Type = Slops      Specific gravity = 0,913  
 Permeability = 100 %  
 Trim = 0 m (+ve by stern); Heel = 0 deg to starboard

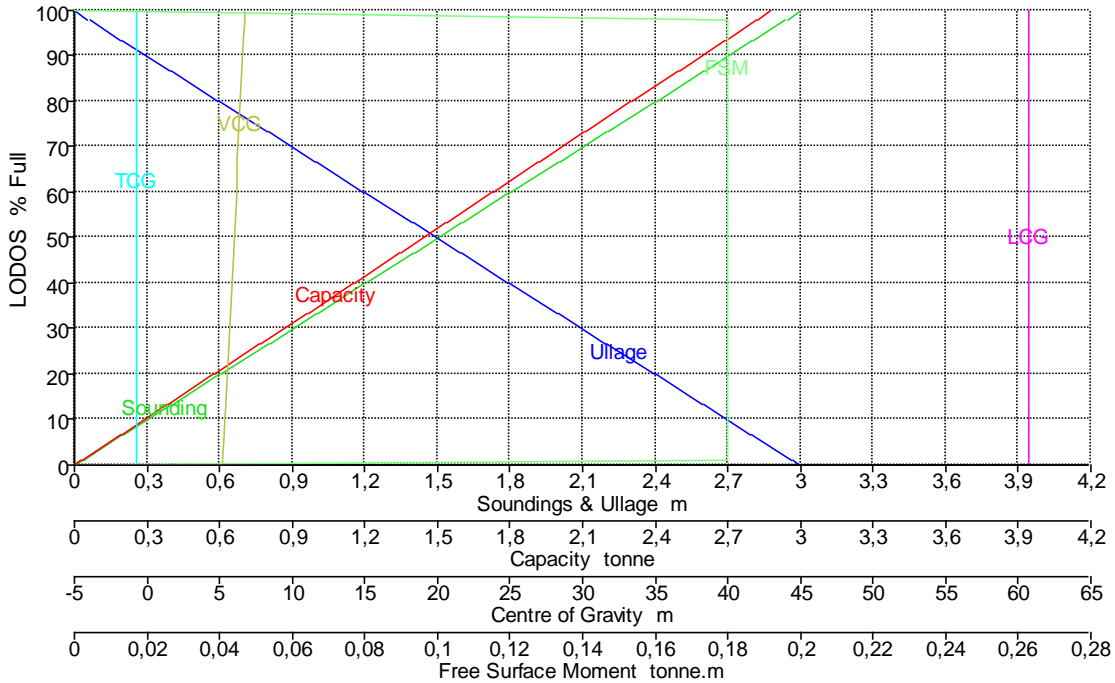

| Tank Name | Sounding m | Ullage m | % Full  | Capacity m <sup>3</sup> | Capacity tonne | LCG m  | TCG m  | VCG m | FSM tonne.m |
|-----------|------------|----------|---------|-------------------------|----------------|--------|--------|-------|-------------|
| LODOS     | 3,000      | 0,000    | 100,000 | 3,150                   | 2,876          | 60,750 | -0,750 | 6,740 | 0,000       |
|           | 2,940      | 0,060    | 98,000  | 3,087                   | 2,818          | 60,750 | -0,750 | 6,710 | 0,180       |
|           | 2,937      | 0,063    | 97,900  | 3,084                   | 2,815          | 60,750 | -0,750 | 6,708 | 0,180       |
|           | 2,800      | 0,200    | 93,337  | 2,940                   | 2,684          | 60,750 | -0,750 | 6,640 | 0,180       |
|           | 2,600      | 0,400    | 86,670  | 2,730                   | 2,492          | 60,750 | -0,750 | 6,540 | 0,180       |
|           | 2,400      | 0,600    | 80,003  | 2,520                   | 2,301          | 60,750 | -0,750 | 6,440 | 0,180       |
|           | 2,200      | 0,800    | 73,336  | 2,310                   | 2,109          | 60,750 | -0,750 | 6,340 | 0,180       |
|           | 2,000      | 1,000    | 66,669  | 2,100                   | 1,917          | 60,750 | -0,750 | 6,240 | 0,180       |
|           | 1,800      | 1,200    | 60,002  | 1,890                   | 1,726          | 60,750 | -0,750 | 6,140 | 0,180       |
|           | 1,600      | 1,400    | 53,335  | 1,680                   | 1,534          | 60,750 | -0,750 | 6,040 | 0,180       |
|           | 1,400      | 1,600    | 46,669  | 1,470                   | 1,342          | 60,750 | -0,750 | 5,940 | 0,180       |
|           | 1,200      | 1,800    | 40,002  | 1,260                   | 1,150          | 60,750 | -0,750 | 5,840 | 0,180       |
|           | 1,000      | 2,000    | 33,335  | 1,050                   | 0,959          | 60,750 | -0,750 | 5,740 | 0,180       |
|           | 0,800      | 2,200    | 26,668  | 0,840                   | 0,767          | 60,750 | -0,750 | 5,640 | 0,180       |
|           | 0,600      | 2,400    | 20,001  | 0,630                   | 0,575          | 60,750 | -0,750 | 5,540 | 0,180       |
|           | 0,400      | 2,600    | 13,334  | 0,420                   | 0,383          | 60,750 | -0,750 | 5,440 | 0,180       |
|           | 0,200      | 2,800    | 6,667   | 0,210                   | 0,192          | 60,750 | -0,750 | 5,340 | 0,180       |
|           | 0,030      | 2,970    | 1,000   | 0,031                   | 0,029          | 60,750 | -0,750 | 5,255 | 0,180       |
|           | 0,000      | 3,000    | 0,000   | 0,000                   | 0,000          | 60,750 | -0,750 | 5,240 | 0,000       |

**Tank Calibrations - SEWAGE**

Fluid Type = Specific gravity = 1  
 Permeability = 100 %  
 Trim = 0 m (+ve by stern); Heel = 0 deg to starboard

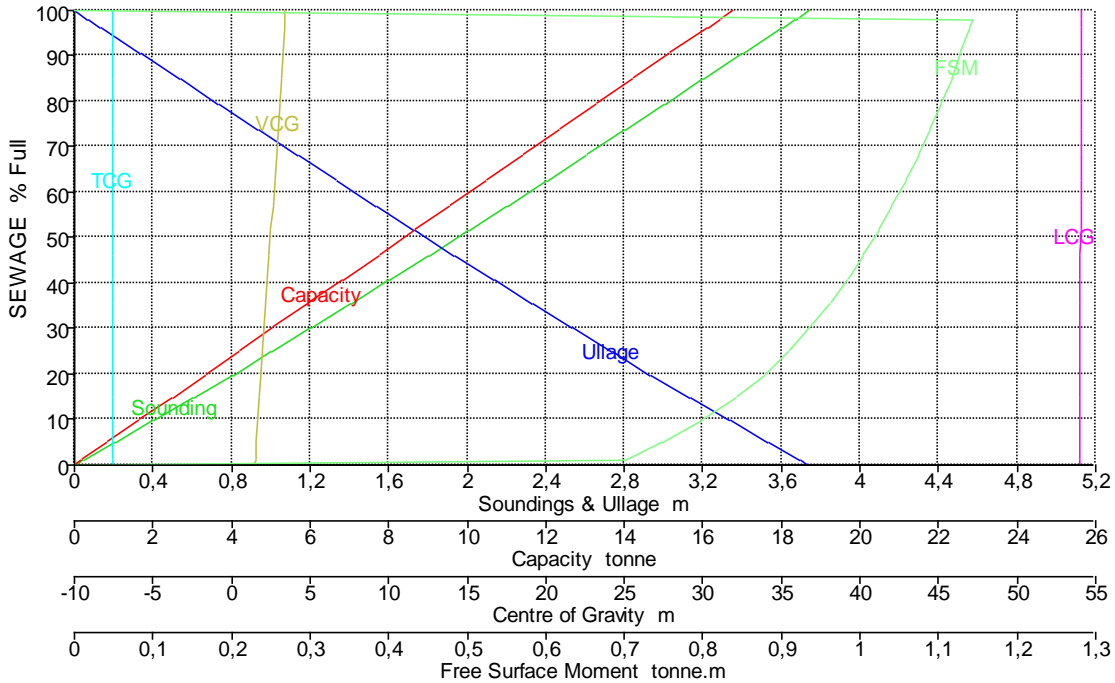

| Tank Name | Sounding m | Ullage m | % Full  | Capacity m <sup>3</sup> | Capacity tonne | LCG m  | TCG m  | VCG m | FSM tonne.m |
|-----------|------------|----------|---------|-------------------------|----------------|--------|--------|-------|-------------|
| SEWAGE    | 3,740      | 0,000    | 100,000 | 16,763                  | 16,763         | 54,056 | -7,615 | 3,421 | 0,000       |
|           | 3,669      | 0,071    | 98,000  | 16,427                  | 16,427         | 54,056 | -7,614 | 3,385 | 1,143       |
|           | 3,666      | 0,074    | 97,900  | 16,411                  | 16,411         | 54,056 | -7,614 | 3,383 | 1,143       |
|           | 3,600      | 0,140    | 96,031  | 16,097                  | 16,097         | 54,055 | -7,613 | 3,349 | 1,139       |
|           | 3,400      | 0,340    | 90,377  | 15,149                  | 15,149         | 54,053 | -7,611 | 3,246 | 1,128       |
|           | 3,200      | 0,540    | 84,744  | 14,205                  | 14,205         | 54,051 | -7,608 | 3,142 | 1,117       |
|           | 3,000      | 0,740    | 79,133  | 13,265                  | 13,265         | 54,049 | -7,605 | 3,039 | 1,104       |
|           | 2,800      | 0,940    | 73,549  | 12,329                  | 12,329         | 54,046 | -7,602 | 2,936 | 1,089       |
|           | 2,600      | 1,140    | 67,993  | 11,397                  | 11,397         | 54,044 | -7,598 | 2,832 | 1,076       |
|           | 2,400      | 1,340    | 62,467  | 10,471                  | 10,471         | 54,042 | -7,595 | 2,729 | 1,059       |
|           | 2,200      | 1,540    | 56,977  | 9,551                   | 9,551          | 54,040 | -7,591 | 2,626 | 1,041       |
|           | 2,000      | 1,740    | 51,522  | 8,636                   | 8,636          | 54,038 | -7,587 | 2,523 | 1,024       |
|           | 1,800      | 1,940    | 46,105  | 7,728                   | 7,728          | 54,036 | -7,583 | 2,419 | 1,004       |
|           | 1,600      | 2,140    | 40,732  | 6,828                   | 6,828          | 54,034 | -7,578 | 2,317 | 0,983       |
|           | 1,400      | 2,340    | 35,404  | 5,935                   | 5,935          | 54,032 | -7,573 | 2,214 | 0,961       |
|           | 1,200      | 2,540    | 30,126  | 5,050                   | 5,050          | 54,030 | -7,568 | 2,111 | 0,936       |
|           | 1,000      | 2,740    | 24,904  | 4,174                   | 4,174          | 54,028 | -7,562 | 2,008 | 0,909       |
|           | 0,800      | 2,940    | 19,744  | 3,310                   | 3,310          | 54,026 | -7,555 | 1,906 | 0,878       |
|           | 0,600      | 3,140    | 14,657  | 2,457                   | 2,457          | 54,024 | -7,548 | 1,804 | 0,842       |
|           | 0,400      | 3,340    | 9,657   | 1,619                   | 1,619          | 54,022 | -7,540 | 1,702 | 0,798       |
|           | 0,200      | 3,540    | 4,764   | 0,799                   | 0,799          | 54,021 | -7,530 | 1,601 | 0,746       |
|           | 0,043      | 3,697    | 1,000   | 0,168                   | 0,168          | 54,019 | -7,521 | 1,521 | 0,699       |
|           | 0,000      | 3,740    | 0,000   | 0,000                   | 0,000          | 54,018 | -7,519 | 1,500 | 0,000       |

### Tank Calibrations - WATER MIST

Fluid Type = Fresh Water    Specific gravity = 1  
 Permeability = 100 %  
 Trim = 0 m (+ve by stern); Heel = 0 deg to starboard

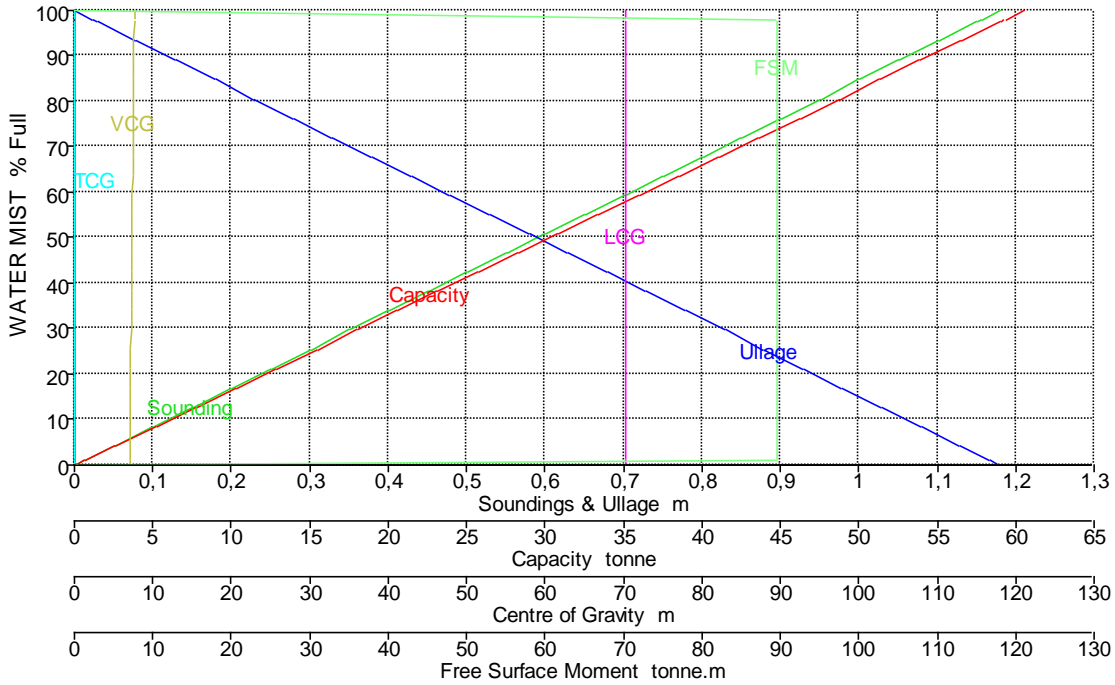

| Tank Name  | Sounding m | Ullage m | % Full  | Capacity m <sup>3</sup> | Capacity tonne | LCG m  | TCG m | VCG m | FSM tonne.m |
|------------|------------|----------|---------|-------------------------|----------------|--------|-------|-------|-------------|
| WATER MIST | 1,180      | 0,000    | 100,000 | 60,529                  | 60,529         | 70,200 | 0,000 | 7,650 | 0,000       |
|            | 1,156      | 0,024    | 98,000  | 59,319                  | 59,319         | 70,200 | 0,000 | 7,638 | 89,667      |
|            | 1,155      | 0,025    | 97,900  | 59,258                  | 59,258         | 70,200 | 0,000 | 7,638 | 89,667      |
|            | 1,150      | 0,030    | 97,458  | 58,990                  | 58,990         | 70,200 | 0,000 | 7,635 | 89,667      |
|            | 1,100      | 0,080    | 93,220  | 56,426                  | 56,426         | 70,200 | 0,000 | 7,610 | 89,667      |
|            | 1,050      | 0,130    | 88,983  | 53,861                  | 53,861         | 70,200 | 0,000 | 7,585 | 89,667      |
|            | 1,000      | 0,180    | 84,746  | 51,296                  | 51,296         | 70,200 | 0,000 | 7,560 | 89,667      |
|            | 0,950      | 0,230    | 80,508  | 48,731                  | 48,731         | 70,200 | 0,000 | 7,535 | 89,667      |
|            | 0,900      | 0,280    | 76,271  | 46,166                  | 46,166         | 70,200 | 0,000 | 7,510 | 89,667      |
|            | 0,850      | 0,330    | 72,034  | 43,602                  | 43,602         | 70,200 | 0,000 | 7,485 | 89,667      |
|            | 0,800      | 0,380    | 67,797  | 41,037                  | 41,037         | 70,200 | 0,000 | 7,460 | 89,667      |
|            | 0,750      | 0,430    | 63,559  | 38,472                  | 38,472         | 70,200 | 0,000 | 7,435 | 89,667      |
|            | 0,700      | 0,480    | 59,322  | 35,907                  | 35,907         | 70,200 | 0,000 | 7,410 | 89,667      |
|            | 0,650      | 0,530    | 55,085  | 33,342                  | 33,342         | 70,200 | 0,000 | 7,385 | 89,667      |
|            | 0,600      | 0,580    | 50,847  | 30,778                  | 30,778         | 70,200 | 0,000 | 7,360 | 89,667      |
|            | 0,550      | 0,630    | 46,610  | 28,213                  | 28,213         | 70,200 | 0,000 | 7,335 | 89,667      |
|            | 0,500      | 0,680    | 42,373  | 25,648                  | 25,648         | 70,200 | 0,000 | 7,310 | 89,667      |
|            | 0,450      | 0,730    | 38,136  | 23,083                  | 23,083         | 70,200 | 0,000 | 7,285 | 89,667      |
|            | 0,400      | 0,780    | 33,898  | 20,518                  | 20,518         | 70,200 | 0,000 | 7,260 | 89,667      |
|            | 0,350      | 0,830    | 29,661  | 17,954                  | 17,954         | 70,200 | 0,000 | 7,235 | 89,667      |
|            | 0,300      | 0,880    | 25,424  | 15,389                  | 15,389         | 70,200 | 0,000 | 7,210 | 89,667      |
|            | 0,250      | 0,930    | 21,186  | 12,824                  | 12,824         | 70,200 | 0,000 | 7,185 | 89,667      |
|            | 0,200      | 0,980    | 16,949  | 10,259                  | 10,259         | 70,200 | 0,000 | 7,160 | 89,667      |
|            | 0,150      | 1,030    | 12,712  | 7,694                   | 7,694          | 70,200 | 0,000 | 7,135 | 89,667      |
|            | 0,100      | 1,080    | 8,475   | 5,130                   | 5,130          | 70,200 | 0,000 | 7,110 | 89,667      |
|            | 0,050      | 1,130    | 4,237   | 2,565                   | 2,565          | 70,200 | 0,000 | 7,085 | 89,667      |
|            | 0,012      | 1,168    | 1,000   | 0,605                   | 0,605          | 70,200 | 0,000 | 7,066 | 89,667      |
|            | 0,000      | 1,180    | 0,000   | 0,000                   | 0,000          | 70,200 | 0,000 | 7,060 | 0,000       |

**Tank Calibrations - HOT WATER**

Fluid Type = Fresh Water    Specific gravity = 1  
 Permeability = 100 %  
 Trim = 0 m (+ve by stern); Heel = 0 deg to starboard

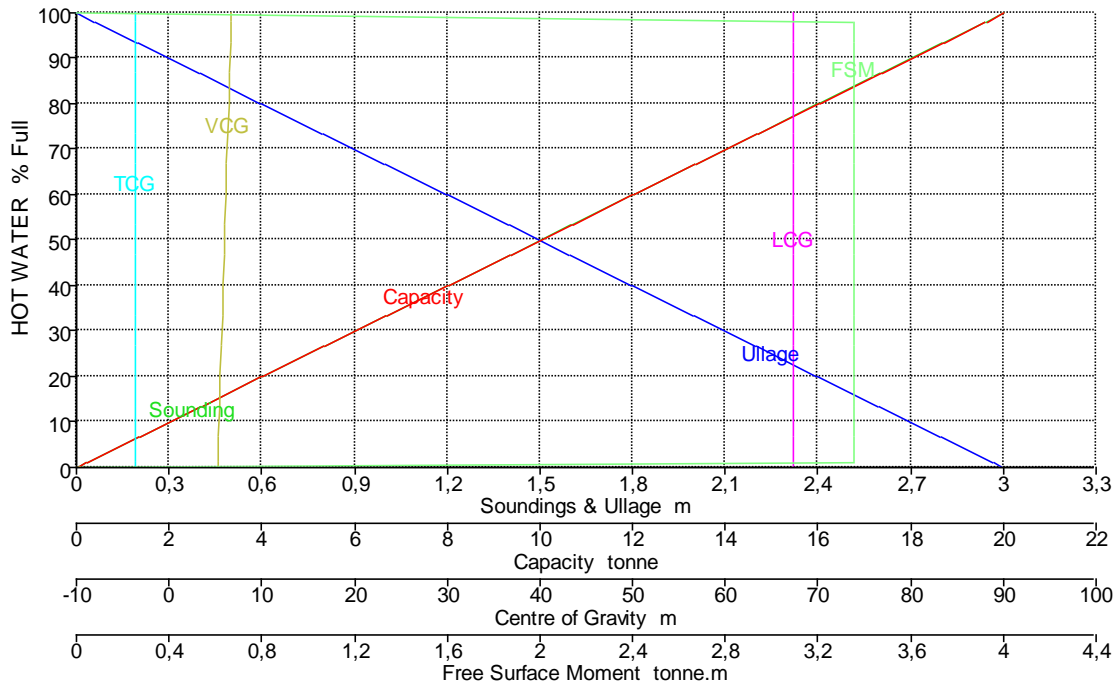

| Tank Name | Sounding m | Ullage m | % Full  | Capacity m <sup>3</sup> | Capacity tonne | LCG m  | TCG m  | VCG m | FSM tonne.m |
|-----------|------------|----------|---------|-------------------------|----------------|--------|--------|-------|-------------|
| HOT WATER | 3,000      | 0,000    | 100,000 | 20,021                  | 20,021         | 67,319 | -3,584 | 6,740 | 0,000       |
|           | 2,940      | 0,060    | 98,000  | 19,621                  | 19,621         | 67,319 | -3,584 | 6,710 | 3,353       |
|           | 2,937      | 0,063    | 97,900  | 19,601                  | 19,601         | 67,319 | -3,584 | 6,709 | 3,353       |
|           | 2,800      | 0,200    | 93,333  | 18,687                  | 18,687         | 67,319 | -3,584 | 6,640 | 3,353       |
|           | 2,600      | 0,400    | 86,667  | 17,352                  | 17,352         | 67,319 | -3,584 | 6,540 | 3,353       |
|           | 2,400      | 0,600    | 80,000  | 16,017                  | 16,017         | 67,319 | -3,584 | 6,440 | 3,353       |
|           | 2,200      | 0,800    | 73,333  | 14,682                  | 14,682         | 67,319 | -3,584 | 6,340 | 3,353       |
|           | 2,000      | 1,000    | 66,667  | 13,348                  | 13,348         | 67,319 | -3,584 | 6,240 | 3,353       |
|           | 1,800      | 1,200    | 60,000  | 12,013                  | 12,013         | 67,319 | -3,584 | 6,140 | 3,353       |
|           | 1,600      | 1,400    | 53,333  | 10,678                  | 10,678         | 67,319 | -3,584 | 6,040 | 3,353       |
|           | 1,400      | 1,600    | 46,667  | 9,343                   | 9,343          | 67,319 | -3,584 | 5,940 | 3,353       |
|           | 1,200      | 1,800    | 40,000  | 8,009                   | 8,009          | 67,319 | -3,584 | 5,840 | 3,353       |
|           | 1,000      | 2,000    | 33,333  | 6,674                   | 6,674          | 67,319 | -3,584 | 5,740 | 3,353       |
|           | 0,800      | 2,200    | 26,667  | 5,339                   | 5,339          | 67,319 | -3,584 | 5,640 | 3,353       |
|           | 0,600      | 2,400    | 20,000  | 4,004                   | 4,004          | 67,319 | -3,584 | 5,540 | 3,353       |
|           | 0,400      | 2,600    | 13,333  | 2,670                   | 2,670          | 67,319 | -3,584 | 5,440 | 3,353       |
|           | 0,200      | 2,800    | 6,667   | 1,335                   | 1,335          | 67,319 | -3,584 | 5,340 | 3,353       |
|           | 0,030      | 2,970    | 1,000   | 0,200                   | 0,200          | 67,319 | -3,584 | 5,255 | 3,353       |
|           | 0,000      | 3,000    | 0,000   | 0,000                   | 0,000          | 67,319 | -3,584 | 5,240 | 0,000       |

### Tank Calibrations - UREA

Fluid Type = UREA    Specific gravity = 1,32  
 Permeability = 98 %  
 Trim = 0 m (+ve by stern); Heel = 0 deg to starboard

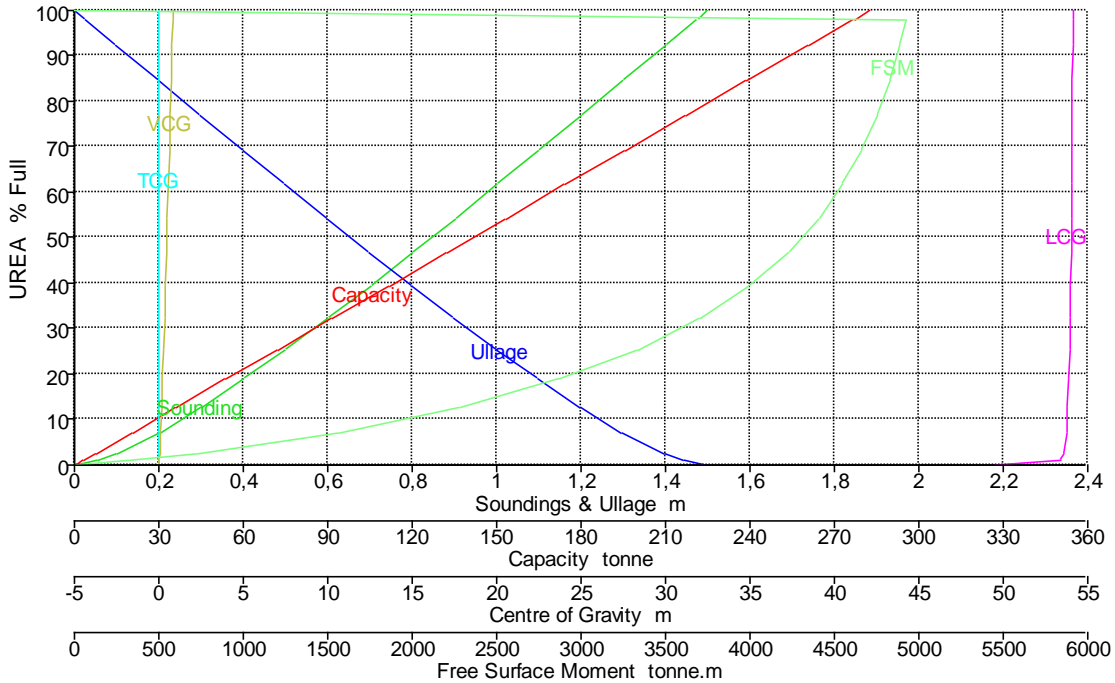

| Tank Name | Sounding m | Ullage m | % Full  | Capacity m <sup>3</sup> | Capacity tonne | LCG m  | TCG m | VCG m | FSM tonne.m |
|-----------|------------|----------|---------|-------------------------|----------------|--------|-------|-------|-------------|
| UREA      | 1,500      | 0,000    | 100,000 | 213,774                 | 282,181        | 54,122 | 0,000 | 0,827 | 0,000       |
|           | 1,474      | 0,026    | 98,000  | 209,498                 | 276,538        | 54,120 | 0,000 | 0,814 | 4927,066    |
|           | 1,473      | 0,027    | 97,900  | 209,284                 | 276,255        | 54,120 | 0,000 | 0,813 | 4926,426    |
|           | 1,400      | 0,100    | 92,275  | 197,259                 | 260,382        | 54,112 | 0,000 | 0,775 | 4887,874    |
|           | 1,300      | 0,200    | 84,545  | 180,735                 | 238,570        | 54,101 | 0,000 | 0,723 | 4826,333    |
|           | 1,200      | 0,300    | 76,853  | 164,292                 | 216,865        | 54,089 | 0,000 | 0,670 | 4752,053    |
|           | 1,100      | 0,400    | 69,209  | 147,951                 | 195,295        | 54,074 | 0,000 | 0,617 | 4661,270    |
|           | 1,000      | 0,500    | 61,624  | 131,736                 | 173,892        | 54,058 | 0,000 | 0,563 | 4548,170    |
|           | 0,900      | 0,600    | 54,115  | 115,684                 | 152,703        | 54,039 | 0,000 | 0,509 | 4405,410    |
|           | 0,800      | 0,700    | 46,705  | 99,842                  | 131,791        | 54,016 | 0,000 | 0,455 | 4224,670    |
|           | 0,700      | 0,800    | 39,422  | 84,275                  | 111,243        | 53,990 | 0,000 | 0,401 | 3994,363    |
|           | 0,600      | 0,900    | 32,310  | 69,071                  | 91,174         | 53,960 | 0,000 | 0,346 | 3700,966    |
|           | 0,500      | 1,000    | 25,426  | 54,354                  | 71,748         | 53,923 | 0,000 | 0,290 | 3327,074    |
|           | 0,400      | 1,100    | 18,850  | 40,296                  | 53,191         | 53,878 | 0,000 | 0,234 | 2856,607    |
|           | 0,300      | 1,200    | 12,700  | 27,149                  | 35,837         | 53,819 | 0,000 | 0,177 | 2269,202    |
|           | 0,200      | 1,300    | 7,161   | 15,308                  | 20,206         | 53,730 | 0,000 | 0,120 | 1554,647    |
|           | 0,100      | 1,400    | 2,575   | 5,505                   | 7,267          | 53,558 | 0,000 | 0,062 | 717,560     |
|           | 0,054      | 1,445    | 1,000   | 2,138                   | 2,822          | 53,360 | 0,000 | 0,034 | 324,500     |
|           | 0,000      | 1,500    | 0,000   | 0,000                   | 0,000          | 49,452 | 0,000 | 0,000 | 0,000       |

**Tank Calibrations - DO DRAIN**

Fluid Type = Slops      Specific gravity = 0,913  
 Permeability = 100 %  
 Trim = 0 m (+ve by stern); Heel = 0 deg to starboard



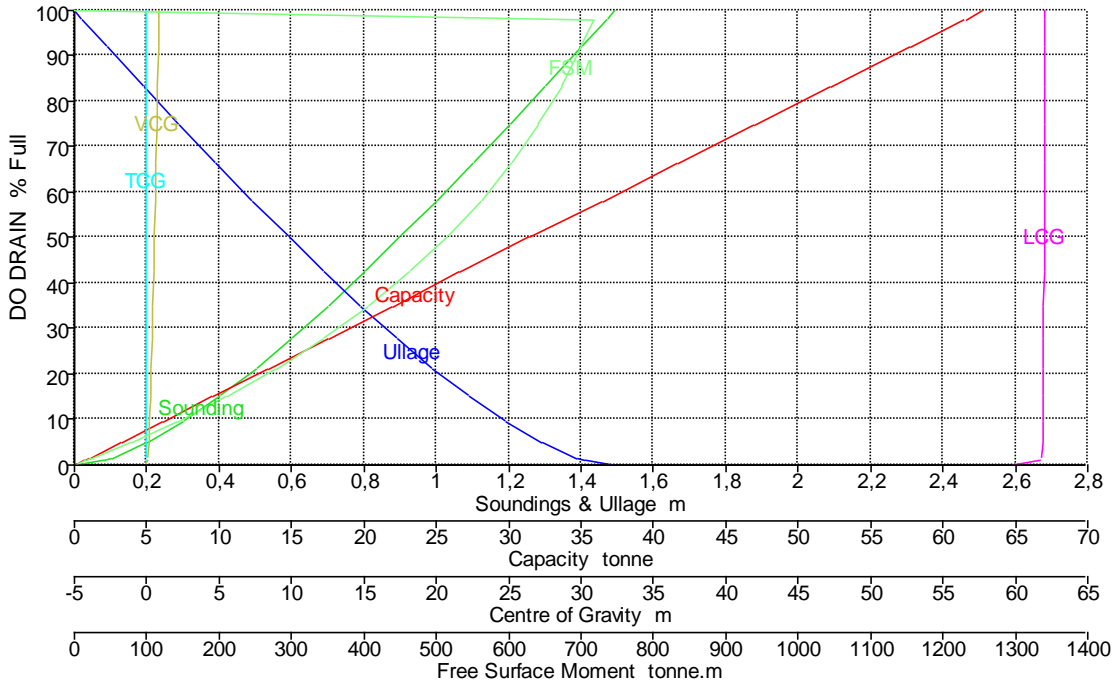

| Tank Name | Sounding m | Ullage m | % Full  | Capacity m <sup>3</sup> | Capacity tonne | LCG m  | TCG m | VCG m | FSM tonne.m |
|-----------|------------|----------|---------|-------------------------|----------------|--------|-------|-------|-------------|
| DO DRAIN  | 1,492      | 0,000    | 100,000 | 68,731                  | 62,752         | 62,009 | 0,000 | 0,877 | 0,000       |
|           | 1,470      | 0,023    | 98,000  | 67,357                  | 61,497         | 62,008 | 0,000 | 0,864 | 717,415     |
|           | 1,468      | 0,024    | 97,900  | 67,288                  | 61,434         | 62,008 | 0,000 | 0,864 | 717,151     |
|           | 1,400      | 0,092    | 91,889  | 63,156                  | 57,662         | 62,006 | 0,000 | 0,826 | 700,538     |
|           | 1,300      | 0,192    | 83,200  | 57,184                  | 52,209         | 62,002 | 0,000 | 0,770 | 672,922     |
|           | 1,200      | 0,292    | 74,643  | 51,303                  | 46,839         | 61,998 | 0,000 | 0,714 | 640,987     |
|           | 1,100      | 0,392    | 66,242  | 45,529                  | 41,568         | 61,993 | 0,000 | 0,658 | 604,145     |
|           | 1,000      | 0,492    | 58,027  | 39,882                  | 36,413         | 61,989 | 0,000 | 0,601 | 562,077     |
|           | 0,900      | 0,592    | 50,033  | 34,388                  | 31,397         | 61,983 | 0,000 | 0,544 | 514,727     |
|           | 0,800      | 0,692    | 42,301  | 29,074                  | 26,544         | 61,977 | 0,000 | 0,487 | 462,178     |
|           | 0,700      | 0,792    | 34,876  | 23,971                  | 21,885         | 61,970 | 0,000 | 0,429 | 404,845     |
|           | 0,600      | 0,892    | 27,815  | 19,117                  | 17,454         | 61,962 | 0,000 | 0,371 | 343,274     |
|           | 0,500      | 0,992    | 21,186  | 14,561                  | 13,295         | 61,951 | 0,000 | 0,313 | 277,990     |
|           | 0,400      | 1,092    | 15,082  | 10,366                  | 9,464          | 61,936 | 0,000 | 0,254 | 210,079     |
|           | 0,300      | 1,192    | 9,626   | 6,616                   | 6,041          | 61,915 | 0,000 | 0,194 | 141,625     |
|           | 0,200      | 1,292    | 5,006   | 3,441                   | 3,141          | 61,879 | 0,000 | 0,134 | 76,554      |
|           | 0,100      | 1,392    | 1,538   | 1,057                   | 0,965          | 61,791 | 0,000 | 0,073 | 22,929      |
|           | 0,079      | 1,414    | 1,000   | 0,687                   | 0,628          | 61,749 | 0,000 | 0,059 | 14,405      |
|           | 0,000      | 1,492    | 0,000   | 0,000                   | 0,000          | 59,728 | 0,000 | 0,008 | 0,000       |

**Tank Calibrations - LNG**

Fluid Type = LNG      Specific gravity = 0,45  
 Permeability = 100 %  
 Trim = 0 m (+ve by stern); Heel = 0 deg to starboard

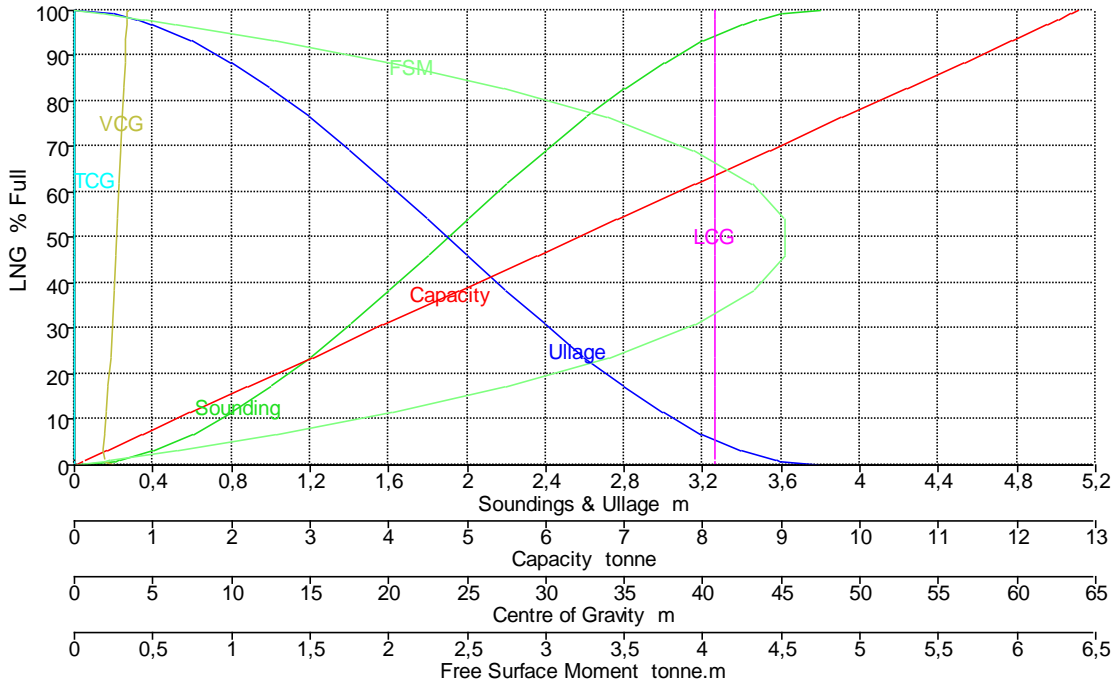

| Tank Name | Sounding m | Ullage m | % Full  | Capacity m <sup>3</sup> | Capacity tonne | LCG m  | TCG m | VCG m | FSM tonne.m |
|-----------|------------|----------|---------|-------------------------|----------------|--------|-------|-------|-------------|
| LNG       | 3,800      | 0,000    | 100,000 | 28,389                  | 12,775         | 40,800 | 0,001 | 3,400 | 0,000       |
|           | 3,600      | 0,200    | 99,184  | 28,158                  | 12,671         | 40,800 | 0,001 | 3,386 | 0,184       |
|           | 3,479      | 0,321    | 98,000  | 27,821                  | 12,520         | 40,800 | 0,001 | 3,366 | 0,431       |
|           | 3,472      | 0,328    | 97,900  | 27,793                  | 12,507         | 40,800 | 0,001 | 3,365 | 0,451       |
|           | 3,400      | 0,400    | 96,890  | 27,506                  | 12,378         | 40,800 | 0,001 | 3,348 | 0,649       |
|           | 3,200      | 0,600    | 93,344  | 26,499                  | 11,925         | 40,800 | 0,001 | 3,294 | 1,279       |
|           | 3,000      | 0,800    | 88,547  | 25,138                  | 11,312         | 40,800 | 0,001 | 3,224 | 2,014       |
|           | 2,800      | 1,000    | 82,898  | 23,534                  | 10,590         | 40,800 | 0,001 | 3,145 | 2,735       |
|           | 2,600      | 1,200    | 76,374  | 21,682                  | 9,757          | 40,800 | 0,001 | 3,055 | 3,400       |
|           | 2,400      | 1,400    | 69,288  | 19,670                  | 8,852          | 40,800 | 0,001 | 2,959 | 3,940       |
|           | 2,200      | 1,600    | 61,751  | 17,530                  | 7,889          | 40,800 | 0,001 | 2,857 | 4,321       |
|           | 2,000      | 1,800    | 53,945  | 15,314                  | 6,891          | 40,800 | 0,001 | 2,749 | 4,524       |
|           | 1,800      | 2,000    | 46,057  | 13,075                  | 5,884          | 40,800 | 0,001 | 2,637 | 4,524       |
|           | 1,600      | 2,200    | 38,251  | 10,859                  | 4,887          | 40,800 | 0,001 | 2,521 | 4,321       |
|           | 1,400      | 2,400    | 30,713  | 8,719                   | 3,924          | 40,800 | 0,001 | 2,409 | 3,940       |
|           | 1,200      | 2,600    | 23,627  | 6,708                   | 3,018          | 40,800 | 0,001 | 2,285 | 3,400       |
|           | 1,000      | 2,800    | 17,103  | 4,855                   | 2,185          | 40,800 | 0,001 | 2,156 | 2,735       |
|           | 0,800      | 3,000    | 11,454  | 3,252                   | 1,463          | 40,800 | 0,001 | 2,051 | 2,014       |
|           | 0,600      | 3,200    | 6,657   | 1,890                   | 0,850          | 40,800 | 0,001 | 1,903 | 1,279       |
|           | 0,400      | 3,400    | 3,110   | 0,883                   | 0,397          | 40,800 | 0,001 | 1,832 | 0,649       |
|           | 0,224      | 3,576    | 1,000   | 0,284                   | 0,128          | 40,800 | 0,001 | 1,932 | 0,224       |
|           | 0,200      | 3,600    | 0,816   | 0,232                   | 0,104          | 40,800 | 0,001 | 1,909 | 0,184       |
|           | 0,000      | 3,800    | 0,000   | 0,000                   | 0,000          | 40,800 | 0,001 | 2,652 | 0,000       |