

YATE DE 87m

# PREDICCIÓN DE POTENCIA Y DISEÑO DE PROPULSORES Y TIMONES

## Cuaderno 6

Autor: Víctor Jesús Gavín Barberán  
Proyecto: 18-105 Yate de lujo de 87m

Contacto: 617 872 329  
vj617872329@icloud.com





Escola Politécnica Superior  
UNIVERSIDADE DA CORUÑA

**DEPARTAMENTO DE INGENIERÍA NAVAL Y OCEÁNICA E INGENIERIA INDUSTRIAL**

**PROYECTO FIN DE MASTER**

*CURSO 2.017-2.018*

**PROYECTO NÚMERO 18-105**

**TIPO DE BUQUE:** *YATE DE LUJO DE DESPLAZAMIENTO*

**CLASIFICACIÓN , COTA Y REGLAMENTOS DE APLICACIÓN :** *BUQUE DE PASAJE, OCEANICO, SOLAS MARPOL MCA. MARPOL*

**CARACTERÍSTICAS DE LA CARGA:** *PERSONAS EN CRUCEROS TURÍSTICOS DE GRAN LUJO*

**VELOCIDAD Y AUTONOMÍA:** *15 KN A MOTOR DE VELOCIDAD MAXIMA*

**SISTEMAS Y EQUIPOS DE CARGA / DESCARGA:** *GRUA A BORDO, JACUZZI, GARAJE PARA MOTOS DE AGUA*

**PROPULSIÓN:** *UNO O DOS MOTORES DIESEL*

**TRIPULACIÓN Y PASAJE:** *40 PASAJEROS 20 TRIPULANTES*

**OTROS EQUIPOS E INSTALACIONES:** *GARAJE, HELICE TRASVERSAL PROA, HELIDECK*

ALUMNO: D. VICTOR GAVIN

TUTOR: D. VICENTE DIAZ

Ferrol, Abril de 2018

# ÍNDICE

## CUADERNO 6

1. Introducción
2. Estimación de la resistencia al avance
3. Estimación de la potencia propulsora
4. Selección de la planta propulsora
5. Cálculo de la hélice
6. Cálculo del timón
  - 6.1 Tipo de timón
  - 6.2 Cálculo del área del timón
  - 6.3 Cálculo altura del timón
  - 6.4 Cálculo cuerda del timón
  - 6.5 Relación de compensación
  - 6.6 Tipo de perfil
  - 6.7 Cálculo del diámetro de la mecha del timón
  - 6.8 Cálculo de la fuerza sobre la pala
  - 6.9 Cálculo del par torsor y potencia del servo
7. Croquis: perfil del propulsor, codaste y timón

# Anexos

## CUADERNO 6

- I. Método Holtrop: *anexo 6.3.1*
- II. Report resistencia al avance: *anexo 6.3.2*
- III. Report potencia propulsora: *anexo 6.4.1*
- IV. Especificación técnica: *anexo 6.5.1*
- V. Detalle 10V 2000 M93 MTU: *anexo 6.5.2*

# 1 Introducción

Una vez desarrolladas las formas del buque y definidos los trimados de las diferentes condiciones de carga, se puede calcular ahora la potencia necesaria para propulsar el buque a la velocidad requerida en los RPA (15 kn de motor a velocidad máxima). Además, ya que no se define en los RPA, hay que justificar la elección del número de motores y el número de hélices que se instalarán en el yate.

La especial dificultad que se presenta en este cuaderno es que no existe un método de predicción de potencia específico para buques de estas características.

En esta ocasión, para la predicción de potencia se empleará el software NavCad, ya que tiene implementado numerosos métodos de predicción de potencia (58 métodos diferentes para todo tipo de buques). Una vez definidos los parámetros del proyecto, el programa selecciona de entre todos los métodos los que más se ajustan a las variables propias de cada método.

Para la propulsión del buque se instalará lo típico en este tipo de barcos: 2 hélices alimentadas por dos líneas de ejes accionadas por una planta diesel convencional.

Estando las formas y condiciones de carga del buque desarrollados, todos los valores requeridos para el cálculo de este cuaderno ya están definidos.

## Dimensiones del Buque

<b>L</b>	<b>Eslora</b>	<b>87,5 m</b>
<b>L<sub>pp</sub></b>	<b>Eslora perpendiculares</b>	<b>73 m</b>
<b>L<sub>wl</sub></b>	<b>Eslora flotación</b>	<b>78,86 m</b>
<b>B</b>	<b>Manga</b>	<b>13,47 m</b>
<b>T</b>	<b>Calado</b>	<b>4,32 m</b>
<b>D</b>	<b>Puntal a c. super</b>	<b>7,61 m</b>
	<b>Tripulación</b>	<b>20</b>
	<b>Pasaje</b>	<b>40</b>

## 2 Estimación de la resistencia al avance

Para calcular la resistencia al avance se utilizará el software NavCad v14, al que le proporcionaremos los distintos valores, dimensiones y coeficientes del buque.

Los datos que se introducirán en el programa se tomarán en primer lugar de los obtenidos en anteriores cuadernos de este proyecto mediante el software MaxSurf, y se completará con las hidrostáticas del buque al calado de diseño.

Seguidamente realizaremos un estudio detallando todos los parámetros que vamos a introducir en el software.

- I. **Condition** En este parámetro se van a definir las características principales del buque, su velocidad y propulsión.

<b>Project</b>		
Project ID:	TFG_Yate de lujo	
Description:		
<b>Summary</b>		
Scope:	ITTC-78 (CT)	▼
Configuration:	Monohull	▼
Chine type:	Round/multiple	▼
Length on WL:	77,290	m
Displacement:	2356,00	t
Propulsor type:	Propeller	▼
Count:	2	▼
<b>Water properties</b>		
Water type:	Salt	▼
Density:	1026,00	kg/m <sup>3</sup>
Viscosity:	1,18920e-6	m <sup>2</sup> /s
<b>Speeds</b>		
Speed [01]	7,00	kt
Speed [02]	8,00	kt
Speed [03]	9,00	kt
Speed [04]	10,00	kt
Speed [05]	11,00	kt
Speed [06]	12,00	kt
Speed [07]	13,00	kt
Speed [08]	14,00	kt
Speed [09]	15,00	kt
Speed [10]	16,00	kt
<b>Design condition</b>		
Design speed:	15,00	▼ kt

**II. Hull** En este parámetro se van a definir las características dimensionales del buque.

<b>Hull</b>		
Configuration:	Monohull	▼
Chine type:	Round/multiple	▼
<b>General</b>		
Length on WL:	78,860	m
Max beam on WL:	13,350	m
Max molded draft:	4,300	m
Displacement:	2356,00	t
Wetted surface:	1198,9	m <sup>2</sup>
Demi-hull spacing:		m
<b>ITTC-78 (CT)</b>		
LCB fwd TR:	39,780	m
LCF fwd TR:	33,550	m
Max section area:	50,5	m <sup>2</sup>
Waterplane area:	832,9	m <sup>2</sup>
Bulb section area:	3,7	m <sup>2</sup>
Bulb ctr below WL:	0,926	m
Bulb nose fwd TR:	83,815	m
Imm transom area:	6,6	m <sup>2</sup>
Transom beam WL:	13,350	m
Transom immersion:	0,500	m
Half entrance angle:	31,00	deg
Bow shape factor:	-1,0	[BTK flow]
Stern shape factor:	0,0	[AVG flow]

\*A los valores de LCB y LCF de las hidrostáticas se le suma la parte a popa de la perpendicular de popa (6,56 m).

**III. Appendage** En este apartado se calculará por predicción por porcentaje, estableciendo como valor el 5% del casco.

**IV. Environment** En este apartado se definen las condiciones meteorológicas. Este apartado no se tendrá en cuenta ya que se introducirá un margen de mar para cubrir estos posibles efectos.

**V. Misc** Se establece como margen de mar un 8%.

Los cálculos se realizan mediante el método más recomendado: **Holtrop**, en su anexo correspondiente se puede ver la info correspondiente a este análisis.

Los resultados obtenidos se presentan en el anexo 6.3.2. Siendo:

- La resistencia total obtenida corresponde a **148,15 KN**.
- La potencia efectiva total obtenida corresponde a **1533 HP**.

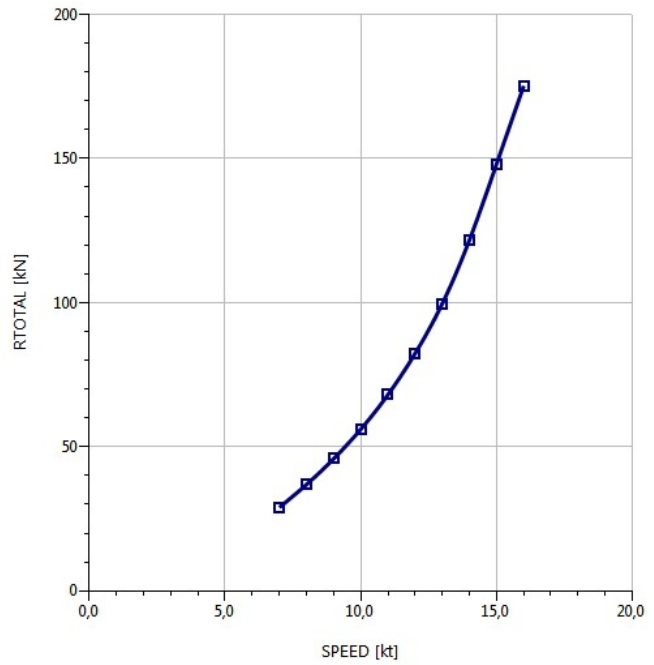
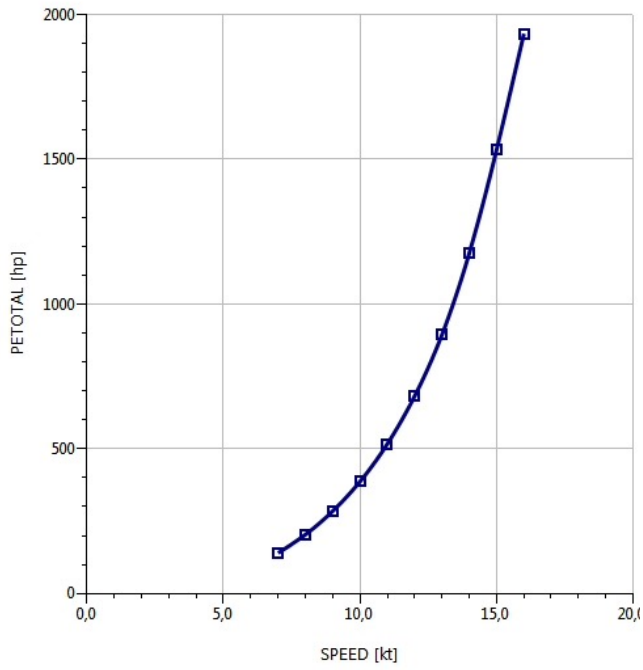

Anexos incluidos en este apartado:

- Método Holtrop: *anexo 6.3.1*
- Report resistencia al avance: *anexo 6.3.2*



### 3 Estimación de la potencia propulsora

A continuación se estimará la potencia al freno en condiciones de navegación libre. El parámetro más importantes a tener en cuenta es la velocidad de servicio del buque, 15 nudos.

Se dimensionará el propulsor mediante empuje, es decir, a partir de la resistencia al avance obtenida en el apartado anterior para la misma velocidad.

Propulsor		
Count:	2	
Propulsor type:	Propeller series	
Propeller type:	FPP	
Propeller series:	B Series	
Propeller sizing:	By thrust	
Reference prop:		
Blade count:	5	
Expanded area ratio:	0,0000	
Propeller diameter:	3500,0	mm
Propeller mean pitch:	2505,8	mm
Hub immersion:	3150,0	mm
Engine/gear		
Engine data:	None defined	
Rated RPM:		RPM
Rated power:		hp
Gear efficiency:	0,970	
Load correction:	Off	
Gear ratio:	3,040	
Shaft efficiency:	0,980	
Propeller options		
Oblique angle corr:	On	
Shaft angle to WL:	4,00	deg
Added rise of run:	0,00	deg
Propeller cup:	0,0	mm
KTKQ corrections:	Standard	
Scale correction:	Full ITTC	
KT multiplier:	1,000	
KQ multiplier:	1,000	
Blade T/C [0.7R]:	Standard	
Roughness:	Standard	mm
Cav breakdown:	Off	
Nozzle L/D:	Standard	

- N° de propulsores: 2
- Tipo de propulsor: FPP
- Serie propulsor: B series
- Dimensionamiento: by thrust
- N° palas: 5 (este dato es provisional)
- Diámetro max. de la hélice: 3,5m
- Inmersión del eje: 3,15m
- Rendimiento reductor: 0,97
- Rendimiento eje: 0,98 (x2)
- Ángulo eje: 4° (dato basado en buque base con idéntico sistema de propulsión)

El método escogido para realizar el calculo será el mismo que en el apartado anterior: **Holtrop**.

El criterio de cavitación utilizado será el de Keller.

Los resultados obtenidos se presentan en el anexo 6.4.1. Siendo:

- La potencia total obtenida corresponde a **2298 HP**.

En las siguientes gráficas se representa la potencia al freno frente a velocidad y la gráfica del rendimiento frente a velocidad.

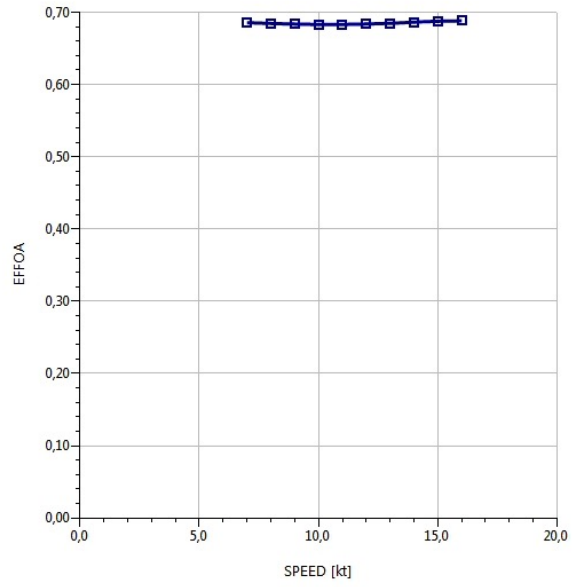
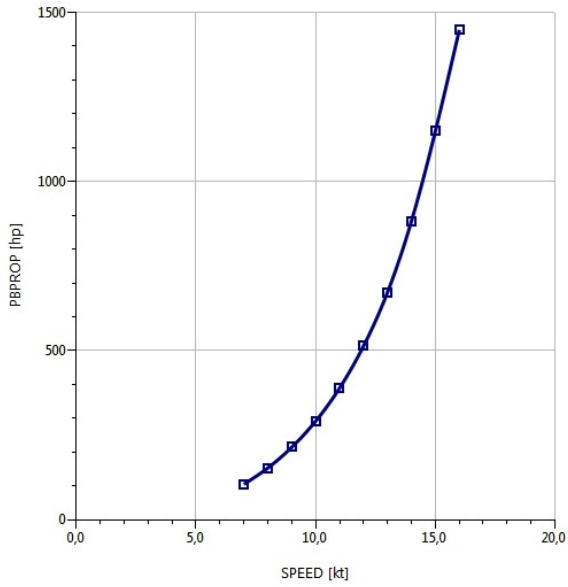

Anexos incluidos en este apartado:

- Report potencia propulsora: *anexo 6.4.1*

## 4 Selección de la planta propulsora

La primera consideración de diseño que deberemos tener en este apartado es que la planta deberá funcionar con un margen en servicio del 85%. Teniendo esta consideración en cuenta:

- La potencia total obtenida en el apartado anterior corresponde a **2298 HP**.

Por lo que para proporcionar un régimen de servicio al 85% debemos contar con **2900HP** que irán repartidos en dos motores diesel.

- Cada unidad deberá proporcionar un mínimo de **1450 HP**.

El suministrador elegido para proporcionar las plantas es MTU. El motivo de esta elección es la serie de motores específicos para yates con las que cuenta y el prestigio con el que la marca cuenta en el sector.

Los equipos seleccionados son dos unidades **10V 2000 M93 MTU**.

Dimensiones del equipo:

Power definition according ISO 3046  
 Intake air temperature 25°C / Sea water temperature 25°C  
 Intake air depression 15 mbar / Exhaust back pressure 30 mbar  
 Barometric pressure 1000 mbar  
 Power reduction at 45°C/32°C: none  
 All engines fulfill IMO emission regulation, certificate on request from April 2005 on  
 All engines EPA Tier 2 certification available from April 2005 on

Dimensions and Masses (incl. gearbox)		10V 2000
Engine Model		
Length [L]	mm (in)	2055 (81.0)
Width [W]	mm (in)	1130 (44.5)
Height [H]	mm (in)	1230 (48.4)
Mass [dry]	kg (lbs)	2700 (5952)

Specifications are subject to change without notice.  
 All dimensions are approximate, for complete information refer to installation drawing.  
 For further information consult your MTU or Detroit Diesel distributor/dealer or any other authorized DaimlerChrysler representative.

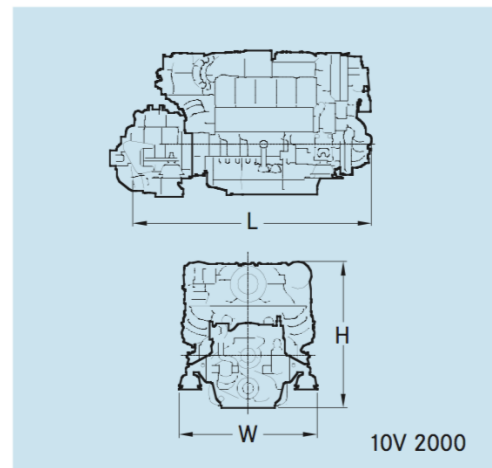

Especificación:

Engine Model		10V 2000 M93
Rated power ICFN	kW (bhp)	1120 (1500)
Speed (speed margin)	rpm	2450 (+50)
No. of cylinders		10
Bore/stroke	mm (in)	135/156 (5.4/6.1)
Displacement, total	l (cu in)	22.3 (1361)
Flywheel housing		SAE 1
Gearbox model		ZF 2050 A
		i = 1.5 - 2.5

Capacidades:

Performance and Fuel Consumption		10V 2000 M93			
Speed	rpm	2450	2200	2000	1200
Maximum power	kW	1120	1080	1000	475
	bhp	1500	1450	1340	635
Power on propeller curve (n <sup>3</sup> )	kW	1120	820	615	135
	bhp	1500	1100	825	180
Fuel consumption	g/kWh	214	207	208	214
	l/h	288.8	204.5	154.1	34.8
	gal/h	76.3	54.0	40.7	9.2

Anexos incluidos en este apartado:

- Especificación técnica: *anexo 6.5.1*
- Detalle 10V 2000 M93 MTU: *anexo 6.5.2*

# 5 Cálculo de la hélice

En este apartado se va a realizar el estudio correspondiente a la especificación de las hélices.

El primer parámetro a estudiar será el número de palas. Continuando con la utilización del software NavCad, el procedimiento de cálculo será similar al del apartado anterior, pero en este caso, conociendo el motor que va a ir instalado, podemos realizar el dimensionamiento utilizando el modo *by power* para asegurar una mayor exactitud en los cálculos.

**Parámetros del motor** extraídos del anexo 6.5.1\_ Especificación técnica MTU 2000 SERIES 8V-10V2000M93:

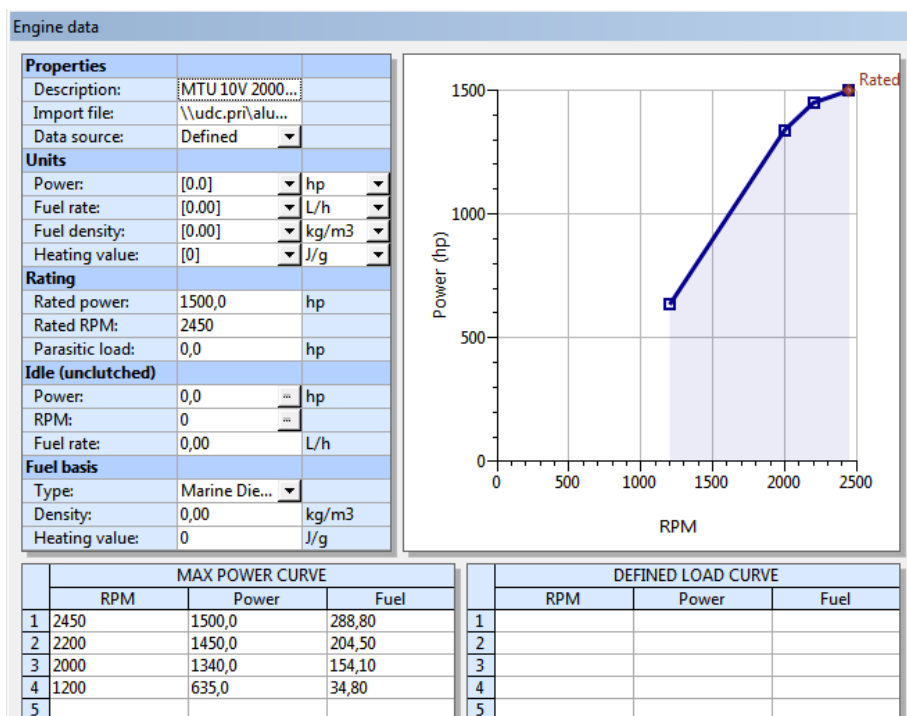

Parámetros de cálculo:

Propeller sizing			
<b>To size</b>			
Gear ratio:	Size	6,563	
Expanded area ratio:	Size	0,588	
Propeller diameter:	Keep	3500,0	mm
Propeller mean pitch:	Keep	3467,9	mm
<b>Design condition</b>			
Design speed:		15,00	kt
Reference power:		13410,0	hp
Design point:		0,850	
Reference RPM:		1150,0	
Design point:		1,050	
Max prop diam:		2500,0	mm
<b>Review</b>			
Tip speed:		0,00	m/s

El número de palas en la hélice estudiado sera el típico en este tipo de buques: 4, 5 y 6 palas.

<b>Nº palas</b>	<b>Eficiencia</b>	<b>Anexo</b>
4	0,6686	6.6.1
5	0,6756	6.6.2
6	0,6771	6.6.3

Es significativo comprobar como ambas hélices ofrecen rendimientos significativamente similares. Esto nos va a permitir una libertad en el momento de escoger una de las diferentes opciones. El buque base cuenta con una hélice de 4 palas. Teniendo esto en cuenta y debido a la diferencia económica que existe entre una hélice de 6 palas y una de 4, se escogerá una hélice de 4 palas para el buque (renunciamos a una eficiencia de 0,85% con esta decisión).

En la siguiente tabla se muestran las características geométricas del propulsor:

#### **Características geométricas del propulsor**

Relación área desarrollada /área de disco AD/A0	0,5883
Diámetro	3,5 m
Inmersión de eje	3,15 m
Cavitación	2 %

# 6 Cálculo del timón

## 6.1 Tipo de timón

El tipo habitual de timón que se instala en este tipo de buques es el **timón suspendido**, que también es el que escogeremos para este proyecto.

La siguiente figura corresponde a la disposición del timón y servo del buque base.

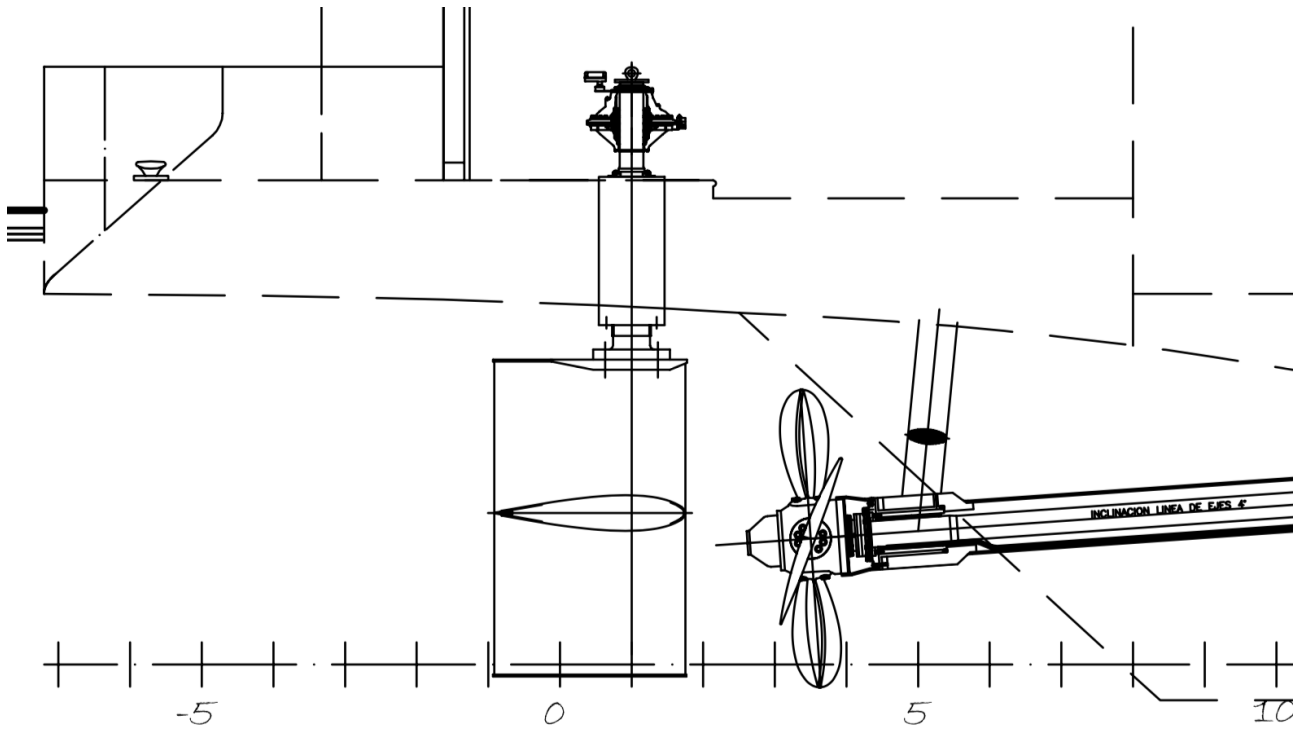

La siguiente figura corresponde a los diferentes tipos de timones descritos en SSC; Parte 3 Cap 3 Sec 2.5:

### 2.5 Rudder arrangements

2.5.1 Rudders considered are the types shown in *Figure 3.2.1 Rudder types*, of double plate or single plate construction, constructed from steel, stainless steel or aluminium alloy. Other rudder types and materials will be subject to special consideration.

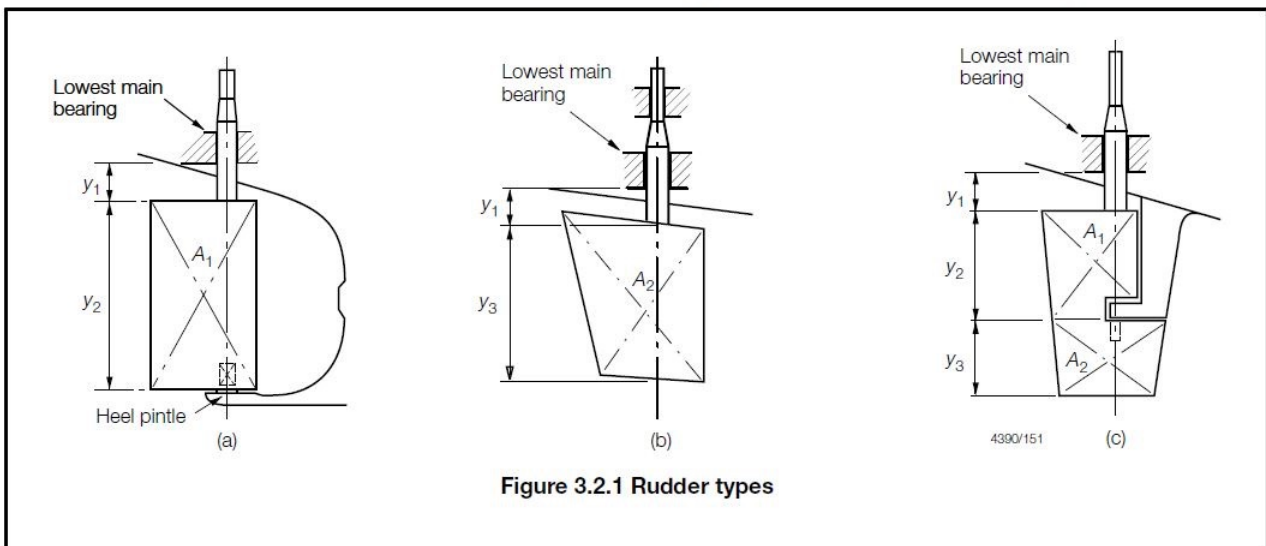

## 6.2 Cálculo del área del timón

La formulación utilizada para realizar este dimensionamiento corresponde a:

- K. Th. Braun:

$$A_R = k(L_{fl} \cdot T)$$

$k = 0,021$  para buques de dos hélices con dos timones

- DNV:

$$A_R = 0,01 \cdot L_{fl} \cdot T \left[ 1 + 25 \left( \frac{B}{L_{fl}} \right)^2 \right]$$

El área del timón es la mitad de la superficie mojada del mismo.

### RESULTADOS

MÉTODO	ÁREA (m <sup>2</sup> )	ÁREA (m <sup>2</sup> ) + 30%	MÉDIA ARITMETICA	ÁREA POR TIMÓN (m <sup>2</sup> )
K. Th. Braun	11,15	14,50	14,33	<b>7,16</b>
DNV	10,89	14,16		

*Principios de teoría del buque. Dinámica. (Juan-García Aguado, José M.)  
Practical ship design. (Watson, D.G.M.)*

Además, se sugiere un aumento del área en un 30% para los casos en el que los timones no se encuentren directamente detrás de la hélice. En este caso, para facilitar las operaciones de mantenimiento del eje y bocina, los timones se situarán a una distancia de  $2,2 \cdot \varnothing_{eje}$ , referencia (11) de modo que se reduce ligeramente la efectividad del timón que se compensará con el aumento del 30%.

*Rudder Control. (Gerr, Dave.)*

El valor que se tomará como área del timón será el medio de los dos valores.



Teniendo en cuenta que vamos a incorporar dos timones, el área media por timón se reduce a 1/2 del valor. La superficie mojada para cada timón resultaría ser este valor x2.

### 6.3 Cálculo altura del timón

Este parámetro está condicionado por la disposición del codaste. Según el SSC la altura del timón debe ser como mínimo un 15% mayor que el diámetro de la hélice. La relación de alargamiento (h/c) tiene una gran influencia en la fuerza del timón. Para un área dada, un timón alto y estrecho genera una fuerza mayor que uno de poca altura y mucha cuerda.

	Diámetro helice (m)	H timón (+15%)
	3,5	<b>4,0</b>

### 6.4 Cálculo cuerda del timón

La podemos calcular a partir del área de timón entre la altura.

	Cuerda = $A_t / H$ timon
	<b>1,79</b>

### 6.5 Relación de compensación

La **compensación (c)** es la relación entre el área a proa de la mecha y el área total del timón. Un valor típico para la compensación es de un **20%** de área del timón a proa del eje. La longitud compensada no debe exceder del 35% de la longitud total del timón.

$$c = \frac{A_{pr}}{A_T} \cdot 100 = 20\%$$

*El proyecto básico del buque mercante. (Alvariño Castro, Ricardo, Azpiroz, Juan José y Meizoso Fernández, Manuel.)*

	A compensada = Compensacion x A total	L compensación = A compensada / H timón
	1,432	<b>0,36</b>

## 6.6 Tipo de perfil

Existen varios perfiles que se emplean habitualmente en los timones. Los más conocidos son los tipo NACA.

Se escogerá la serie "00xx", que es la que mantiene la simetría y, dentro de la serie simétrica, los valores más empleados son los 0015, 0016, 0023. En este caso se escoge el modelo 0015, sugerido en un artículo de la revista Náutica Superyacht de septiembre de 2004. En las siguientes publicaciones también se recomienda este perfil teniendo en cuenta las características del buque.

*Theory of wing sections (Abbott.)*

*Practical Ship Hydrodynamics (Beltram, Volker.)*

*Basic Ship Theory (Rawson, K.J. y Tupper, E.C.)*

Anexos incluidos en este apartado:

- Superyacht 509\_2004: *anexo 6.7.3*

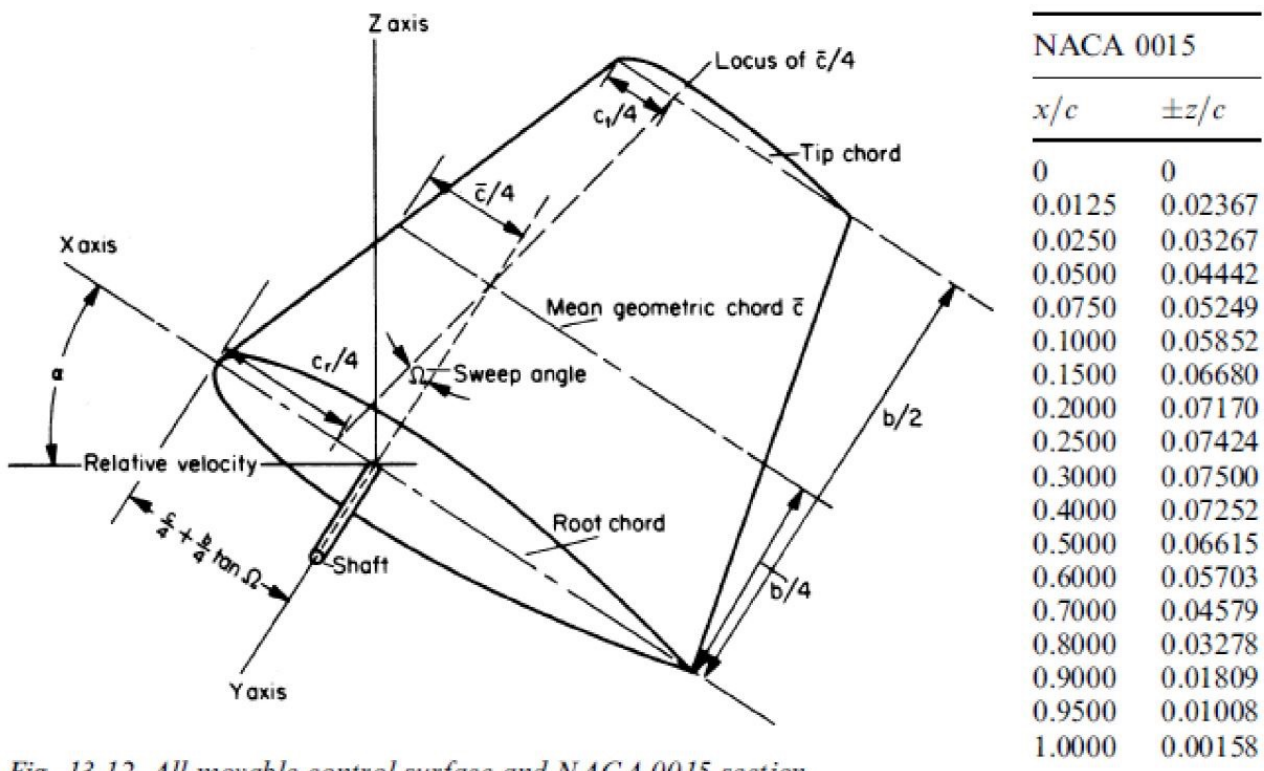

Fig. 13.12 All-movable control surface and NACA 0015 section

## 6.7 Cálculo del diámetro de la mecha del timón

El SSC; Parte 3 Cap 3 Sec 2.12 describe el cálculo del diámetro mínimo de la mecha del timón.

Valores obtenidos:

Requirement
1. Basic stock diameter, $d_s$ , at and below lowest bearing: $d_s = f_c f_p f_v \sqrt[3]{\left(\frac{235}{\sigma_0}\right)^m f_R f_\theta (V+3)^2 \sqrt{A_R^2 x_p^2 + N^2}} \text{ mm}$
2. Diameter in way of tiller, $d_{SU}$ : $d_{SU} = d_s$ calculated from (1) with $N = 0$
3. Lateral force on rudder acting at centre of pressure of blade, $P_L$ : $P_L = \left(\frac{f_p}{0,248}\right)^3 \frac{(V+3)^2 A_R f_R f_\theta}{10} \text{ kN}$
Symbols
$f_c$ = 79 for craft of Rule length, $L_R$ , 50 m and below varying up to 83,3 at a Rule length, $L_R$ , of 70 m. Intermediate values to be obtained by interpolation 83,3 for craft of Rule length, $L_R$ , 70 m and above $f_p$ = rudder position coefficient, see Table 3.2.3 $f_v$ = rudder speed coefficient, see Table 3.2.4 $f_R$ = rudder profile coefficient, see Table 3.2.1 $f_\theta$ = rudder angle coefficient, see Table 3.2.2 $m$ = 0,75 for $\sigma_0 > 235$ = 1,0 for $\sigma_0 \leq 235$ $\sigma_0$ = minimum yield stress, in N/mm <sup>2</sup> , of material used, and is not to be taken greater than $0,7\sigma_T$ $\sigma_T$ = ultimate tensile strength of the material used, in N/mm <sup>2</sup> $V$ = the maximum speed for the astern and ahead condition, in knots. In no case to be less than 5 knots $A_R$ = rudder area, in m <sup>2</sup> $x_p$ = $x_{p_a}$ or $x_{p_i}$ , for the astern and ahead condition respectively, see Table 3.2.6 $N$ = coefficient dependent on rudder support arrangement, see Table 3.2.5
NOTE Where higher tensile steel is used for the rudder stock, $\sigma_0$ is not to be taken as greater than 450 N/mm <sup>2</sup> .

SSC Parte 3 Cap 3 Sec 2.12

Símbolo	Valor	Comentario
$f_c$	83,3	$L_r < 70m$
$f_p$	0,235	Timón no centrado en el flujo
$f_v$	1	$V/(Lw)^{1/2} = 1,68 < 3$
$\sigma$	450	(N/mm <sup>2</sup> ) Acero alta resistencia
$m$	0,75	$\sigma > 235$
$f_r$	1	Perfil tipo normal _ NACA00xx
$f_e$	1	$2 \times 35^\circ$
$V$	15	kn
$A_r$	4,24	Apartado 7.2
$x_p$	0,535	(m) Croquis timón
$N$	0	Two or more pintles
Resultado $d_s$ (mm)	150,18	

## 6.8 Cálculo de la fuerza sobre la pala

La fórmula de Joessel permite obtener el valor de la fuerza que actúa sobre el timón:

$$N = \frac{41,35 \cdot S \cdot V^2 \cdot \text{sen } \alpha}{0,195 + 0,305 \cdot \text{sen } \alpha} \text{ [kgf]}$$

*Principios de teoría del buque (De Juan-García Aguado, José M.)*

<b>N</b>	<b>fuerza normal sobre el timón</b>	<b>kgf</b>	<b>27285,69</b>	<b>26,75 kn</b>
<b>S</b>	superficie del timón	m <sup>2</sup>	7,16	
<b>V</b>	velocidad del buque	m/s	7,71	
<b>α</b>	ángulo del timón respecto plano de crujía	°	35	

## 6.9 Cálculo del par torsor y potencia del servo

El par torsor que debe soportar la mecha es:

$$Q = N \cdot xp$$

<b>Q</b>	<b>par torsor</b>	<b>kNm</b>	<b>14,31</b>
<b>N</b>	fuerza normal sobre el timón	kn	26,75
<b>xp</b>	posición al centro de presiones desde la mecha	m	0,535

**La potencia necesaria para mover el timón** de una banda a otra se determina teniendo en cuenta los requerimientos de la OMI. De modo que, el timón debe moverse desde 35° a una banda a 35° de la otra banda en un tiempo máximo de 28 segundos. (*Chapter II-1 3.2*)

$$P = (Q \cdot \Omega) / n$$

<b>P</b>	<b>potencia necesaria (por timón)</b>	<b>kW</b>	<b>0,79</b>
<b>Q</b>	par torsor	kNm	14,31
<b>Ω</b>	velocidad angular	rad/s	0,044
<b>n</b>	rendimiento		0,8

# 7 Croquis: perfil del propulsor, codaste y timón

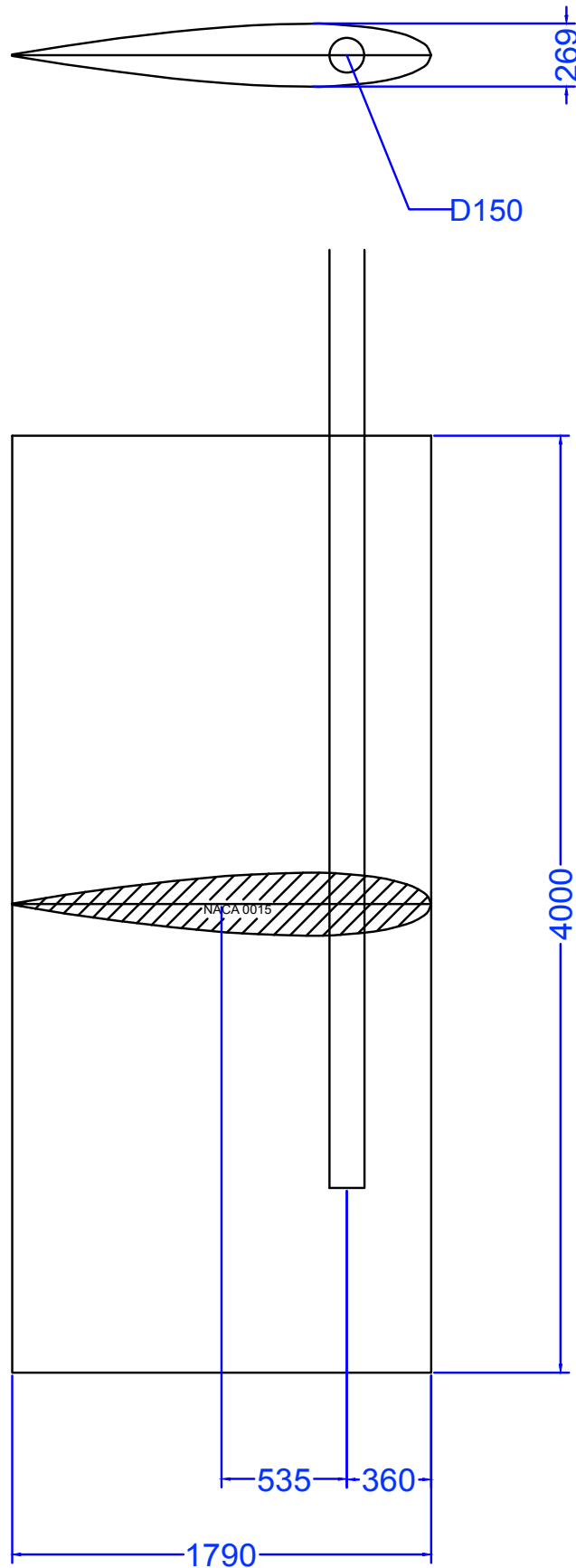

# ANEXO 6.3.1

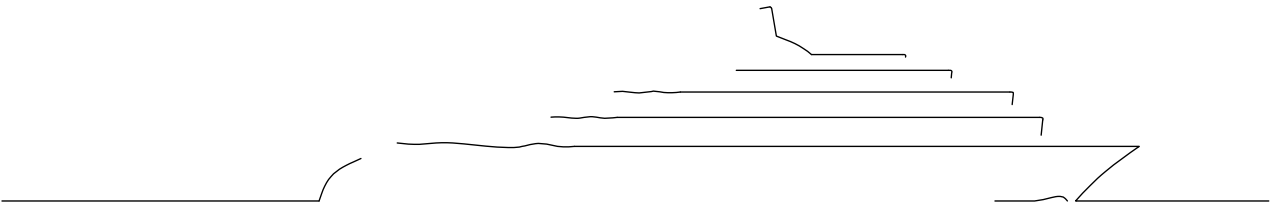

YATE DE 87m

<b>Reference</b>	Holtrop, J., "A Statistical Re-Analysis of Resistance and Propulsion Data", International Shipbuilding Progress, Vol. 31, No. 363 Nov 1984. Holtrop, J., "A Statistical Resistance Prediction Method With a Speed Dependent Form Factor", Proceedings SMSSH '88, Varna, Oct 1988. Holtrop, J. and Mennen, G.G.J., "An Approximate Power Prediction Method", International Shipbuilding Progress, Vol. 29, No. 335, July 1982. Holtrop, J., and Mennen, G.G.J., "A Statistical Power Prediction Method", International Shipbuilding Progress, Vol. 25, October 1978.
<b>Vessel type</b>	Commercial and naval vessels, Single and twin-screw
<b>Prediction scope</b>	Hull: Data estimates Resistance: Bare-hull resistance Propulsion: Hull-propulsor interaction coefficients
<b>Parameters</b>	Propellers 1-2 Cp(LWL) 0.55-0.85 LWL/BWL 3.9-14.9 BWL/T 2.1-4.0 Lambda 0-max determined by FN (see Remarks below) Includes analysis for: Immersed transom and bulbous bow
<b>Speed range</b>	FN(LWL) 0.06-0.80 [see note] <b>Note:</b> The upper limit for the speed range may be shown as less than in the original publication. HydroComp has identified and developed an upper speed constraint that is a function of certain hull parameters, notably transom immersion. The <i>Method Expert</i> will adjust the upper speed limit of this method based on this constraint.
<b>Formula error</b>	Not presented.
<b>Methodology</b>	3-D Cw, ITTC-57 Cf, random model tests and full scale trial data. Pseudo-drag coefficient. Full scale, open propellers.
<b>Remarks</b>	A random collection of 334 models of tankers, bulk carriers, cargo ships, fishing vessels, tugs, container ships and military craft make up the data set.  <b>[Resistance]</b> Widely regarded as a complete and reliable method for cruiser stern ships, it seems to underpredict resistance for transom-stern craft. (Use of the speed-dependent form factor correction improves this tendency.)  The regression is derived with a speed-dependent relationship using the Havelock wave shape as its foundation. The basis for the use of the Havelock theory is currently out of favor, as a speed-dependent analysis like Havelock has trouble matching the typical Cw/CR curve shape below FN of about 0.3  An additional parameter – lambda – has been added to the data check for this method. Anecdotal experience and testing by HydroComp have identified combinations of hull parameters that produce significant errors with the Holtrop method, and lambda has proven to be an indicator of these potential errors. Lambda is a parameter used within the Holtrop method and is equal to $1.446 * C_p - 0.03 * L/B$ . A recommended upper limit for lambda has been developed by HydroComp and is used in the data check and the Method Expert ranking.

# ANEXO 6.3.2

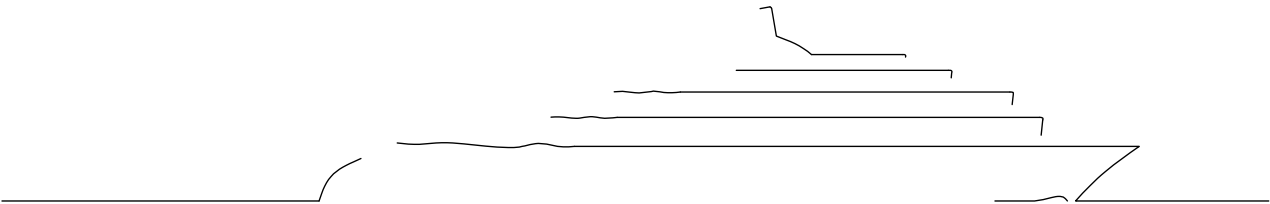

YATE DE 87m



# Resistance

Project ID **TFG\_Yate de lujo**  
 Description  
 File name **navcad cuaderno 6.hcnc**

HydroComp NavCad 2014

## Analysis parameters

<b>Vessel drag</b>		<b>ITTC-78 (CT)</b>	<b>Added drag</b>	
Technique:	[Calc] Prediction		Appendage:	[Calc] Percentage
Prediction:	Holtrop		Wind:	[Off]
Reference ship:			Seas:	[Off]
Model LWL:			Shallow/channel:	[Off]
Expansion:	Custom		Towed:	[Off]
Friction line:	ITTC-57		Margin:	[Calc] Hull drag only [8%]
Hull form factor:	[On] 1,283		<b>Water properties</b>	
Speed corr:	[Off]		Water type:	Salt
Spray drag corr:	[Off]		Density:	1026,00 kg/m3
Corr allowance:	0,000374		Viscosity:	1,18920e-6 m2/s
Roughness [mm]:	[On] 0,15			

## Prediction method check [Holtrop]

Parameters	FN [design]	CP	LWL/BWL	BWL/T	Lambda
Value	0,28	0,58	5,91	3,10	0,66
Range	0,06-0,76	0,55-0,85	3,90-14,90	2,10-4,00	0,01-0,98

## Prediction results

SPEED [kt]	SPEED COEFS		ITTC-78 COEFS						
	FN	FV	RN	CF	[CTLT/CF]	CR	dCF	CA	CT
7,00	0,129	0,317	2,39e8	0,001844	1,283	0,000473	0,000000	0,000374	0,003212
8,00	0,148	0,362	2,73e8	0,001811	1,283	0,000438	0,000000	0,000374	0,003135
9,00	0,166	0,407	3,07e8	0,001782	1,283	0,000417	0,000000	0,000374	0,003078
10,00	0,185	0,452	3,41e8	0,001757	1,283	0,000421	0,000000	0,000374	0,003050
11,00	0,203	0,498	3,75e8	0,001735	1,283	0,000459	0,000000	0,000374	0,003059
12,00	0,222	0,543	4,09e8	0,001715	1,283	0,000535	0,000000	0,000374	0,003110
13,00	0,240	0,588	4,43e8	0,001698	1,283	0,000654	0,000000	0,000374	0,003206
14,00	0,259	0,633	4,78e8	0,001681	1,283	0,000846	0,000000	0,000374	0,003377
+ 15,00 +	0,277	0,678	5,12e8	0,001666	1,283	0,001068	0,000000	0,000374	0,003580
16,00	0,296	0,724	5,46e8	0,001652	1,283	0,001227	0,000000	0,000374	0,003721
RESISTANCE									
SPEED [kt]	RBARE [kN]	RAPP [kN]	RWIND [kN]	RSEAS [kN]	RCHAN [kN]	RTOWED [kN]	RMARGIN [kN]	RTOTAL [kN]	
7,00	25,62	1,28	0,00	0,00	0,00	2,05	2,05	28,95	
8,00	32,65	1,63	0,00	0,00	0,00	2,61	2,61	36,90	
9,00	40,58	2,03	0,00	0,00	0,00	3,25	3,25	45,85	
10,00	49,65	2,48	0,00	0,00	0,00	3,97	3,97	56,10	
11,00	60,26	3,01	0,00	0,00	0,00	4,82	4,82	68,09	
12,00	72,90	3,64	0,00	0,00	0,00	5,83	5,83	82,38	
13,00	88,20	4,41	0,00	0,00	0,00	7,06	7,06	99,67	
14,00	107,74	5,39	0,00	0,00	0,00	8,62	8,62	121,74	
+ 15,00 +	131,10	6,56	0,00	0,00	0,00	10,49	10,49	148,15	
16,00	155,05	7,75	0,00	0,00	0,00	12,40	12,40	175,21	
EFFECTIVE POWER									
SPEED [kt]	PEBARE [hp]	PETOTAL [hp]	CTLR	CTLT	RBARE/W				
7,00	123,7	139,8	0,00974	0,06613	0,00111				
8,00	180,2	203,7	0,00901	0,06453	0,00141				
9,00	252,0	284,7	0,00859	0,06336	0,00176				
10,00	342,5	387,0	0,00868	0,06279	0,00215				
11,00	457,3	516,7	0,00945	0,06298	0,00261				
12,00	603,5	682,0	0,01102	0,06403	0,00316				
13,00	791,0	893,9	0,01347	0,06601	0,00382				
14,00	1040,6	1175,8	0,01741	0,06952	0,00466				
+ 15,00 +	1356,7	1533,0	0,02198	0,07369	0,00567				
16,00	1711,5	1934,0	0,02526	0,07660	0,00671				

# Resistance

HydroComp NavCad 2014

Project ID **TFG\_Yate de lujo**  
 Description  
 File name **navcad cuaderno 6.hcnc**

## Hull data

General		Planing	
Configuration:	<b>Monohull</b>	<i>Proj chine length:</i>	<b>0,000 m</b>
Chine type:	<b>Round/multiple</b>	<i>Proj bottom area:</i>	<b>0,0 m2</b>
Length on WL:	<b>78,860 m</b>	<i>LCG fwd TR:</i>	<b>[XCG/LP 0,000] 0,000 m</b>
Max beam on WL:	[LWL/BWL 5,907] <b>13,350 m</b>	<i>VCG below WL:</i>	<b>0,000 m</b>
Max molded draft:	[BWL/T 3,105] <b>4,300 m</b>	<i>Aft station (fwd TR):</i>	<b>0,000 m</b>
Displacement:	[CB 0,507] <b>2356,00 t</b>	<i>Deadrise:</i>	<b>0,00 deg</b>
Wetted surface:	[CS 2,817] <b>1198,9 m2</b>	<i>Chine beam:</i>	<b>0,000 m</b>
<b>ITTC-78 (CT)</b>		<i>Chine ht below WL:</i>	<b>0,000 m</b>
LCB fwd TR:	[XCB/LWL 0,504] <b>39,780 m</b>	<i>Fwd station (fwd TR):</i>	<b>0,000 m</b>
LCF fwd TR:	[XCF/LWL 0,425] <b>33,550 m</b>	<i>Deadrise:</i>	<b>0,00 deg</b>
Max section area:	[CX 0,880] <b>50,5 m2</b>	<i>Chine beam:</i>	<b>0,000 m</b>
Waterplane area:	[CWP 0,791] <b>832,9 m2</b>	<i>Chine ht below WL:</i>	<b>0,000 m</b>
Bulb section area:	<b>3,7 m2</b>	<i>Propulsor type:</i>	<b>Propeller</b>
Bulb ctr below WL:	<b>0,926 m</b>	<i>Max prop diameter:</i>	<b>2500,0 mm</b>
Bulb nose fwd TR:	<b>83,815 m</b>	<i>Shaft angle to WL:</i>	<b>2,00 deg</b>
Imm transom area:	[ATR/AX 0,131] <b>6,6 m2</b>	<i>Position fwd TR:</i>	<b>0,000 m</b>
Transom beam WL:	[BTR/BWL 1,000] <b>13,350 m</b>	<i>Position below WL:</i>	<b>0,000 m</b>
Transom immersion:	[TTR/T 0,116] <b>0,500 m</b>	<i>Transom lift device:</i>	<b>Flap</b>
Half entrance angle:	<b>31,00 deg</b>	<i>Device count:</i>	<b>0</b>
Bow shape factor:	[BTK flow] <b>-1,0</b>	<i>Span:</i>	<b>0,000 m</b>
Stern shape factor:	[AVG flow] <b>0,0</b>	<i>Chord length:</i>	<b>0,000 m</b>
		<i>Deflection angle:</i>	<b>0,00 deg</b>
		<i>Tow point fwd TR:</i>	<b>0,000 m</b>
		<i>Tow point below WL:</i>	<b>0,000 m</b>

# Resistance

HydroComp NavCad 2014

Project ID **TFG\_Yate de lujo**  
 Description  
 File name **navcad cuaderno 6.hcnc**

## Appendage data

<b>General</b>		<b>Skeg/Keel</b>	
Definition:	<b>Percentage</b>	Count:	<b>0</b>
Percent of hull drag:	<b>5,00 %</b>	Type:	<b>Skeg</b>
<b>Planing influence</b>		Mean length:	<b>0,000 m</b>
LCE fwd TR:	<b>0,000 m</b>	Mean width:	<b>0,000 m</b>
VCE below WL:	<b>0,000 m</b>	Height aft:	<b>0,000 m</b>
<b>Shafting</b>		Height mid:	<b>0,000 m</b>
Count:	<b>2</b>	Height fwd:	<b>0,000 m</b>
Max prop diameter:	<b>2500,0 mm</b>	Projected area:	<b>0,0 m2</b>
Shaft angle to WL:	<b>2,00 deg</b>	Wetted surface:	<b>0,0 m2</b>
Exposed shaft length:	<b>0,000 m</b>	<b>Stabilizer</b>	
Shaft diameter:	<b>0,000 m</b>	Count:	<b>0</b>
Wetted surface:	<b>0,0 m2</b>	Root chord:	<b>0,000 m</b>
Strut bossing length:	<b>0,000 m</b>	Tip chord:	<b>0,000 m</b>
Bossing diameter:	<b>0,000 m</b>	Span:	<b>0,000 m</b>
Wetted surface:	<b>0,0 m2</b>	T/C ratio:	<b>0,000</b>
Hull bossing length:	<b>0,000 m</b>	LE sweep:	<b>0,00 deg</b>
Bossing diameter:	<b>0,000 m</b>	Wetted surface:	<b>0,0 m2</b>
Wetted surface:	<b>0,0 m2</b>	Projected area:	<b>0,0 m2</b>
<b>Strut (per shaft line)</b>		Dynamic multiplier:	<b>1,00</b>
Count:	<b>0</b>	<b>Bilge keel</b>	
Root chord:	<b>0,000 m</b>	Count:	<b>0</b>
Tip chord:	<b>0,000 mm</b>	Mean length:	<b>0,000 m</b>
Span:	<b>0,000 m</b>	Mean base width:	<b>0,000 m</b>
T/C ratio:	<b>0,000</b>	Mean projection:	<b>0,000 m</b>
Projected area:	<b>0,0 m2</b>	Wetted surface:	<b>0,0 m2</b>
Wetted surface:	<b>0,0 m2</b>	<b>Tunnel thruster</b>	
Exposed palm depth:	<b>0,000 m</b>	Count:	<b>0</b>
Exposed palm width:	<b>0,000 m</b>	Diameter:	<b>0,000 m</b>
<b>Rudder</b>		<b>Sonar dome</b>	
Count:	<b>0</b>	Count:	<b>0</b>
Rudder location:	<b>Behind propeller</b>	Wetted surface:	<b>0,0 m2</b>
Type:	<b>Balanced foil</b>	<b>Miscellaneous</b>	
Root chord:	<b>0,000 m</b>	Count:	<b>0</b>
Tip chord:	<b>0,000 m</b>	Drag area:	<b>0,0 m2</b>
Span:	<b>0,000 m</b>	Drag coef:	<b>0,00</b>
T/C ratio:	<b>0,000</b>		
LE sweep:	<b>0,00 deg</b>		
Projected area:	<b>0,0 m2</b>		
Wetted surface:	<b>0,0 m2</b>		

## Environment data

<b>Wind</b>		<b>Seas</b>	
Wind speed:	<b>0,00 kt</b>	Significant wave ht:	<b>0,000 m</b>
Angle off bow:	<b>0,00 deg</b>	Modal wave period:	<b>0,0 sec</b>
Gradient correction:	<b>Off</b>	<b>Shallow/channel</b>	
<b>Exposed hull</b>		Water depth:	<b>0,000 m</b>
Transverse area:	<b>0,0 m2</b>	Type:	<b>Shallow water</b>
VCE above WL:	<b>0,000 m</b>	Channel width:	<b>0,000 m</b>
Profile area:	<b>0,0 m2</b>	Channel side slope:	<b>0,00 deg</b>
<b>Superstructure</b>		Hull girth:	<b>0,000 m</b>
Superstructure shape:	<b>Cargo ship</b>		
Transverse area:	<b>0,0 m2</b>		
VCE above WL:	<b>0,000 m</b>		
Profile area:	<b>0,0 m2</b>		

# Resistance

HydroComp NavCad 2014

Project ID TFG\_Yate de lujo  
Description  
File name navcad cuaderno 6.hcnc

## Symbols and values

SPEED = Vessel speed  
FN = Froude number [LWL]  
FV = Froude number [VOL]  
RN = Reynolds number [LWL]  
CF = Frictional resistance coefficient  
CV/CF = Viscous/frictional resistance coefficient ratio [dynamic form factor]  
CR = Residuary resistance coefficient  
dCF = Added frictional resistance coefficient for roughness  
CA = Correlation allowance [dynamic]  
CT = Total bare-hull resistance coefficient  
RBARE = Bare-hull resistance  
RAPP = Additional appendage resistance  
RWIND = Additional wind resistance  
RSEAS = Additional sea-state resistance  
RCHAN = Additional shallow/channel resistance  
RTOWED = Additional towed object resistance  
RMARGIN = Resistance margin  
RTOTAL = Total vessel resistance  
PEBARE = Bare-hull effective power  
PETOTAL = Total effective power  
CTLR = Telfer residuary resistance coefficient  
CTLT = Telfer total bare-hull resistance coefficient  
RBARE/W = Bare-hull resistance to weight ratio  
+ = Design speed indicator  
\* = Exceeds parameter limit

# ANEXO 6.4.1

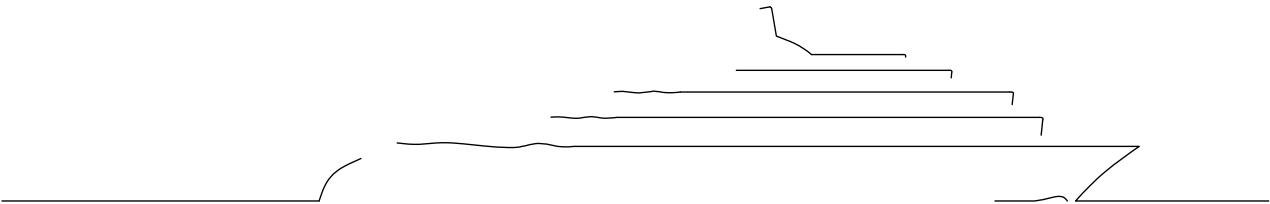

YATE DE 87m

# Propulsion

HydroComp NavCad 2014

Project ID **TFG\_Yate de lujo**  
 Description  
 File name **navcad cuaderno 6.hcnc**

## Analysis parameters

Hull-propulsor interaction		System analysis	
Technique:	[Calc] Prediction	Cavitation criteria:	Keller eqn
Prediction:	Holtrop	Analysis type:	Free run
Reference ship:		CPP method:	
Max prop diam:	2500,0 mm	Engine RPM:	
<b>Corrections</b>		Mass multiplier:	
Viscous scale corr:	[On] Custom	RPM constraint:	
Rudder location:	Behind propeller	Limit [RPM/s]:	
Friction line:	ITTC-57	<b>Water properties</b>	
Hull form factor:	1,283	Water type:	Salt
Corr allowance:	0,000374	Density:	1026,00 kg/m3
Roughness [mm]:	[On] 0,15	Viscosity:	1,18920e-6 m2/s
Ducted prop corr:	[Off]		
Tunnel stern corr:	[Off]		
Effective diam:			
Recess depth:			

## Prediction method check [Holtrop]

Parameters	FN [design]	CP	LWL/BWL	BWL/T
Value	0,28	0,58	5,91	3,10
Range	0,06-0,80	0,55-0,85	3,90-14,90	2,10-4,00

## Prediction results [System]

SPEED [kt]	HULL-PROPULSOR				ENGINE			
	PETOTAL [hp]	WFT	THD	EFFR	RPMENG [RPM]	PBPROP [hp]	FUEL [L/h]	LOADENG [%]
7,00	139,8	0,0941	0,1027	0,9913	413	105,1	---	0,0
8,00	203,7	0,0939	0,1027	0,9913	470	153,3	---	0,0
9,00	284,7	0,0937	0,1027	0,9913	528	214,6	---	0,0
10,00	387,0	0,0936	0,1027	0,9913	585	292,0	---	0,0
11,00	516,7	0,0934	0,1027	0,9913	644	389,8	---	0,0
12,00	682,0	0,0933	0,1027	0,9913	705	514,0	---	0,0
13,00	893,9	0,0932	0,1027	0,9913	767	672,8	---	0,0
14,00	1175,8	0,0931	0,1027	0,9913	832	883,0	---	0,0
+ 15,00 +	1533,0	0,0930	0,1027	0,9913	900	1149,1	---	0,0
16,00	1934,0	0,0929	0,1027	0,9913	966	1448,5	---	0,0
SPEED [kt]	POWER DELIVERY							
	RPMPROP [RPM]	QPROP [kN·m]	QENG [kN·m]	PDPROP [hp]	PSPROP [hp]	PSTOTAL [hp]	PBTOTAL [hp]	TRANSP
7,00	63	11,21	1,71	99,9	102,0	203,9	210,2	530,8
8,00	72	14,36	2,19	145,8	148,7	297,5	306,7	415,8
9,00	80	17,92	2,73	204,0	208,2	416,4	429,2	334,2
10,00	89	21,96	3,35	277,5	283,2	566,4	583,9	273,0
11,00	98	26,64	4,06	370,5	378,1	756,2	779,6	224,9
12,00	107	32,12	4,89	488,6	498,6	997,2	1028,1	186,1
13,00	117	38,64	5,89	639,5	652,6	1305,2	1345,5	154,0
14,00	127	46,72	7,12	839,4	856,5	1713,1	1766,0	126,4
+ 15,00 +	137	56,23	8,57	1092,4	1114,7	2229,3	2298,3	104,0
16,00	147	66,04	10,06	1376,9	1405,0	2810,1	2897,0	88,0
SPEED [kt]	EFFICIENCY				THRUST			
	EFFO	EFFG	EFFOA	MERIT	THRPROP [kN]	DELTHR [kN]		
7,00	0,7125	0,9700	0,6857	0,27922	16,13	28,95		
8,00	0,7116	0,9700	0,6846	0,2754	20,56	36,90		
9,00	0,7109	0,9700	0,6838	0,27255	25,55	45,85		
10,00	0,7105	0,9700	0,6833	0,27112	31,26	56,10		
11,00	0,7106	0,9700	0,6833	0,27155	37,94	68,09		
12,00	0,7113	0,9700	0,6839	0,27401	45,90	82,38		
13,00	0,7124	0,9700	0,6849	0,27863	55,54	99,67		
14,00	0,7141	0,9700	0,6864	0,28658	67,84	121,74		
+ 15,00 +	0,7155	0,9700	0,6877	0,29561	82,55	148,15		
16,00	0,7161	0,9700	0,6882	0,30164	97,63	175,21		



# Propulsion

HydroComp NavCad 2014

Project ID TFG\_Yate de lujo  
 Description  
 File name navcad cuaderno 6.hcnc

## Prediction results [Propulsor]

PROPULSOR COEFS									
SPEED [kt]	J	KT	KQ	KTJ2	KQJ3	CTH	CP	RNPROP	
7,00	0,8892	0,0954	0,01894	0,1206	0,026939	0,30712	0,4348	6,91e6	
8,00	0,8925	0,0937	0,01870	0,11763	0,026309	0,29955	0,42464	7,88e6	
9,00	0,8949	0,0925	0,01852	0,11545	0,025849	0,294	0,41721	8,84e6	
10,00	0,8961	0,0918	0,01844	0,11438	0,025622	0,29126	0,41355	9,81e6	
11,00	0,8957	0,0920	0,01846	0,1147	0,02569	0,29208	0,41464	1,08e7	
12,00	0,8936	0,0931	0,01862	0,11657	0,026084	0,29684	0,421	1,18e7	
13,00	0,8897	0,0951	0,01890	0,12015	0,026841	0,30595	0,43322	1,28e7	
14,00	0,8829	0,0986	0,01940	0,12651	0,028198	0,32216	0,45512	1,39e7	
+ 15,00 +	0,8750	0,1026	0,01998	0,13408	0,029827	0,34143	0,48141	1,50e7	
16,00	0,8696	0,1054	0,02037	0,13935	0,03097	0,35485	0,49987	1,61e7	
CAVITATION									
SPEED [kt]	SIGMAV	SIGMAN	SIGMA07R	TIPSPEED [m/s]	MINBAR	PRESS [kPa]	CAVAVG [%]	CAVMAX [%]	PITCHFC [mm]
7,00	24,05	19,02	3,38	11,53	0,069	2,85	2,0	2,0	3335,2
8,00	18,41	14,66	2,60	13,13	0,076	3,63	2,0	2,0	3342,3
9,00	14,54	11,64	2,07	14,73	0,085	4,51	2,0	2,0	3347,5
10,00	11,77	9,45	1,68	16,35	0,095	5,52	2,0	2,0	3350,1
11,00	9,73	7,80	1,38	17,99	0,106	6,70	2,0	2,0	3349,3
12,00	8,17	6,53	1,16	19,68	0,120	8,11	2,0	2,0	3344,8
13,00	6,96	5,51	0,98	21,41	0,137	9,81	2,0	2,0	3336,3
14,00	6,00	4,68	0,83	23,24	0,159	11,98	2,0	2,0	3321,6
+ 15,00 +	5,23	4,00	0,71	25,13	0,185	14,58	2,0	2,0	3304,6
16,00	4,59	3,47	0,62	26,97	0,212	17,25	2,0	2,0	3293,2



# Propulsion

HydroComp NavCad 2014

Project ID **TFG\_Yate de lujo**  
 Description  
 File name **navcad cuaderno 6.hcnc**

## Hull data

General		Planing	
Configuration:	<b>Monohull</b>	<i>Proj chine length:</i>	<b>0,000 m</b>
Chine type:	<b>Round/multiple</b>	<i>Proj bottom area:</i>	<b>0,0 m2</b>
Length on WL:	<b>78,860 m</b>	<i>LCG fwd TR:</i>	<b>[XCG/LP 0,000] 0,000 m</b>
Max beam on WL:	[LWL/BWL 5,907] <b>13,350 m</b>	<i>VCG below WL:</i>	<b>0,000 m</b>
Max molded draft:	[BWL/T 3,105] <b>4,300 m</b>	<i>Aft station (fwd TR):</i>	<b>0,000 m</b>
Displacement:	[CB 0,507] <b>2356,00 t</b>	<i>Deadrise:</i>	<b>0,00 deg</b>
Wetted surface:	[CS 2,817] <b>1198,9 m2</b>	<i>Chine beam:</i>	<b>0,000 m</b>
<b>ITTC-78 (CT)</b>		<i>Chine ht below WL:</i>	<b>0,000 m</b>
LCB fwd TR:	[XCB/LWL 0,504] <b>39,780 m</b>	<i>Fwd station (fwd TR):</i>	<b>0,000 m</b>
LCF fwd TR:	[XCF/LWL 0,425] <b>33,550 m</b>	<i>Deadrise:</i>	<b>0,00 deg</b>
Max section area:	[CX 0,880] <b>50,5 m2</b>	<i>Chine beam:</i>	<b>0,000 m</b>
Waterplane area:	[CWP 0,791] <b>832,9 m2</b>	<i>Chine ht below WL:</i>	<b>0,000 m</b>
Bulb section area:	<b>3,7 m2</b>	<i>Propulsor type:</i>	<b>Propeller</b>
Bulb ctr below WL:	<b>0,926 m</b>	<i>Max prop diameter:</i>	<b>2500,0 mm</b>
Bulb nose fwd TR:	<b>83,815 m</b>	<i>Shaft angle to WL:</i>	<b>2,00 deg</b>
Imm transom area:	[ATR/AX 0,131] <b>6,6 m2</b>	<i>Position fwd TR:</i>	<b>0,000 m</b>
Transom beam WL:	[BTR/BWL 1,000] <b>13,350 m</b>	<i>Position below WL:</i>	<b>0,000 m</b>
Transom immersion:	[TTR/T 0,116] <b>0,500 m</b>	<i>Transom lift device:</i>	<b>Flap</b>
Half entrance angle:	<b>31,00 deg</b>	<i>Device count:</i>	<b>0</b>
Bow shape factor:	[BTK flow] <b>-1,0</b>	<i>Span:</i>	<b>0,000 m</b>
Stern shape factor:	[AVG flow] <b>0,0</b>	<i>Chord length:</i>	<b>0,000 m</b>
		<i>Deflection angle:</i>	<b>0,00 deg</b>
		<i>Tow point fwd TR:</i>	<b>0,000 m</b>
		<i>Tow point below WL:</i>	<b>0,000 m</b>

## Propulsor data

Propulsor		Propeller options	
Count:	<b>2</b>	<i>Oblique angle corr:</i>	<b>On</b>
Propulsor type:	<b>Propeller series</b>	<i>Shaft angle to WL:</i>	<b>4,00 deg</b>
Propeller type:	<b>FPP</b>	<i>Added rise of run:</i>	<b>0,00 deg</b>
Propeller series:	<b>B Series</b>	<i>Propeller cup:</i>	<b>0,0 mm</b>
Propeller sizing:	<b>By thrust</b>	<i>KTKQ corrections:</i>	<b>Standard</b>
Reference prop:		<i>Scale correction:</i>	<b>Full ITTC</b>
Blade count:	<b>5</b>	<i>KT multiplier:</i>	<b>1,000</b>
Expanded area ratio:	<b>0,5883</b> [Size]	<i>KQ multiplier:</i>	<b>1,000</b>
Propeller diameter:	<b>3500,0 mm</b> [Keep]	<i>Blade T/C [0.7R]:</i>	<b>Standard</b>
Propeller mean pitch:	[P/D 0,9908] <b>3467,9 mm</b> [Size]	<i>Roughness:</i>	<b>Standard</b>
Hub immersion:	<b>3150,0 mm</b>	<i>Cav breakdown:</i>	<b>Off</b>
<b>Engine/gear</b>		<b>Design condition</b>	
Engine data:		<i>Max prop diam:</i>	<b>2500,0 mm</b>
Rated RPM:	<b>0 RPM</b>	<i>Design speed:</i>	<b>15,00 kt</b>
Rated power:	<b>0,0 hp</b>	<i>Reference power:</i>	<b>13410,0 hp</b>
Gear efficiency:	<b>0,970</b>	<i>Design point:</i>	<b>0,850</b>
Load correction:	<b>Off</b>	<i>Reference RPM:</i>	<b>1150,0</b>
Gear ratio:	<b>6,563</b> [Size]	<i>Design point:</i>	<b>1,050</b>
Shaft efficiency:	<b>0,980</b>		

# Propulsion

HydroComp NavCad 2014

Project ID TFG\_Yate de lujo  
Description  
File name navcad cuaderno 6.hcnc

## Symbols and values

SPEED = Vessel speed  
PETOTAL = Total vessel effective power  
WFT = Taylor wake fraction coefficient  
THD = Thrust deduction coefficient  
EFFR = Relative-rotative efficiency  
RPMENG = Engine RPM  
PBPROP = Brake power per propulsor  
FUEL = Fuel rate per engine  
LOADENG = Percentage of engine max available power at given RPM  
RPMPROP = Propulsor RPM  
QPROP = Propulsor open water torque  
QENG = Engine torque  
PDPROP = Delivered power per propulsor  
PSPROP = Shaft power per propulsor  
PSTOTAL = Total vessel shaft power  
PBTOTAL = Total vessel brake power  
TRANSP = Transport factor  
EFO = Propulsor open-water efficiency  
EFG = Gear efficiency (load corrected)  
EFOA = Overall propulsion efficiency [=PETOTAL/PSTOTAL]  
MERIT = Propulsor merit coefficient  
THRPROP = Open-water thrust per propulsor  
DELTHR = Total vessel delivered thrust  
J = Propulsor advance coefficient  
KT = Propulsor thrust coefficient [horizontal, if in oblique flow]  
KQ = Propulsor torque coefficient  
KTJ2 = Propulsor thrust loading ratio  
KQJ3 = Propulsor torque loading ratio  
CTH = Horizontal component of bare-hull resistance coefficient  
CP = Propulsor thrust loading coefficient  
RNPROP = Propeller Reynolds number at 0.7R  
SIGMAV = Cavitation number of propeller by vessel speed  
SIGMAN = Cavitation number of propeller by RPM  
SIGMA07R = Cavitation number of blade section at 0.7R  
TIPSPEED = Propeller circumferential tip speed  
MINBAR = Minimum expanded blade area ratio recommended by selected cavitation criteria  
PRESS = Average propeller loading pressure  
CAVAVG = Average predicted back cavitation percentage  
CAVMAX = Peak predicted back cavitation percentage [if in oblique flow]  
PITCHFC = Minimum recommended pitch to avoid face cavitation  
+ = Design speed indicator  
\* = Exceeds recommended parameter limit  
! = Exceeds recommended cavitation criteria [warning]  
!! = Substantially exceeds recommended cavitation criteria [critical]  
!!! = Thrust breakdown is indicated [severe]  
--- = Insignificant or not applicable

# ANEXO 6.5.1

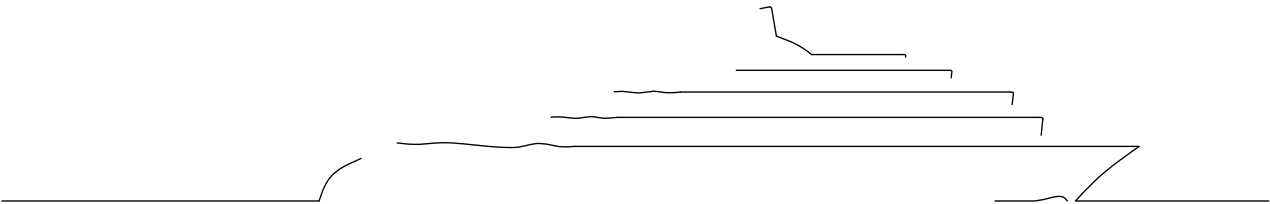

YATE DE 87m

# Diesel Engine Series 8V/10V 2000 M93

for Fast Vessels

with Low Load Factors (1DS)

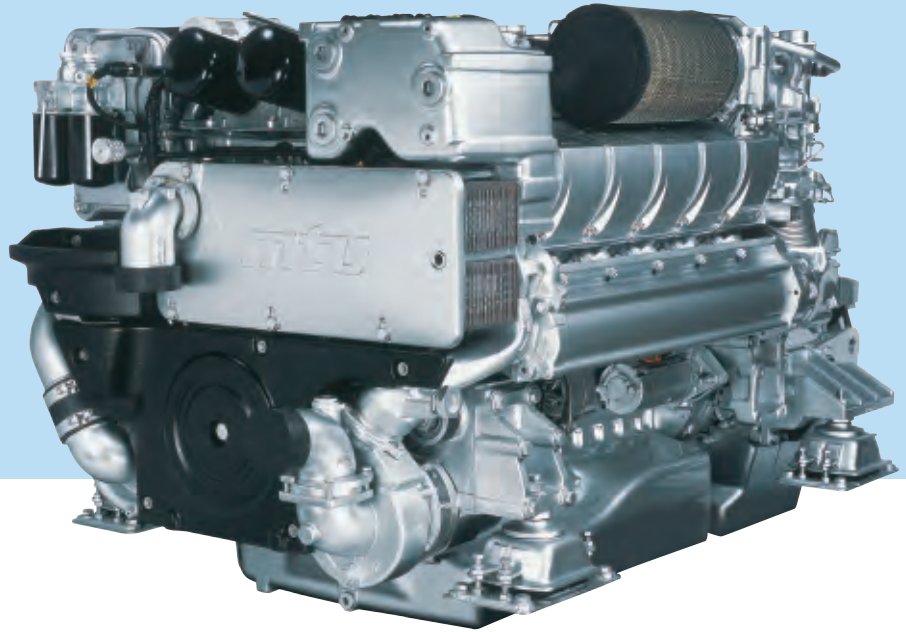

## Typical applications:

Fast Yachts, Fast Patrol Boats,  
Police Craft and Fire-Fighting  
Vessels

Engine Model	8V 2000 M93	10V 2000 M93
Rated power ICFN    kW (bhp)	895 (1200)	1120 (1500)
Speed (speed margin)    rpm	2450 (+50)	2450 (+50)
No. of cylinders	8	10
Bore/stroke            mm (in)	135/156 (5.4/6.1)	135/156 (5.4/6.1)
Displacement, total    l (cu in)	17.9 (1093)	22.3 (1361)
Flywheel housing	SAE 1	SAE 1
Gearbox model	ZF 550 A i = 1.5 - 2.5	ZF 2050 A i = 1.5 - 2.5

Performance and Fuel Consumption	8V 2000 M93				10V 2000 M93				
Speed                    rpm	2450	2200	2000	1200	2450	2200	2000	1200	
Maximum power	kW	895	860	800	375	1120	1080	1000	475
	bhp	1200	1155	1075	505	1500	1450	1340	635
Power on propeller curve (n <sup>3</sup> )	kW	895	650	485	105	1120	820	615	135
	bhp	1200	870	650	140	1500	1100	825	180
Fuel consumption	g/kWh	215	208	210	227	214	207	208	214
	on propeller curve <sup>1)</sup>	l/h	231.8	162.9	122.7	28.7	288.8	204.5	154.1
	gal/h	61.2	43.0	32.4	7.6	76.3	54.0	40.7	9.2

<sup>1)</sup> Tolerance +5% per ISO 3046, Diesel fuel to DIN EN 590 with a min L.H.V. of 42800kJ/kg (18390 BTU/lb)



## Standard Equipment

Starting System	Electric starter motor 24 V
Auxiliary PTO	Charging generator, 80A, 28V, 2 pole
Oil System	Gear driven lube oil pump, lube-oil duplex filter with diverter valve, lube-oil heat exchanger, handpump for oil extraction
Fuel System	Fuel feed pump, fuel hand pump, fuel pre-filter, fuel main filter with diverter valve, on-engine fuel oil cooler, HP fuel pump, jacketed HP fuel lines, injection nozzles (CR system), flame proof hose lines, leak-off fuel tank level monitored
Cooling System	Coolant-to-raw water plate core heat exchanger, self priming centrifugal raw water pump, gear driven coolant circulation pump
Combustion Air System	Sequential turbocharging with 2 water-cooled exhaust-gas turbochargers, on-engine set of combustion-air filters
Exhaust System	Triple-walled, liquid-cooled, on-engine exhaust manifolds, single centrally located exhaust outlet, 1 exhaust bellows vertical discharge
Mounting System	Resilient mounts at free end
Engine Management System	Engine and gearbox control and monitoring system (ADEC)

## Optional Equipment

Auxiliary PTO	Charging generator, 140A, 28V, 2 pole, bilgepump, on-engine PTOs
Fuel System	Duplex fuel pre-filter
Cooling System	Coolant preheating system, integr. seawater gearbox piping
Exhaust System	1 exhaust bellows horizontal discharge
Mounting System	Resilient mounts at driving end
Monitoring / Control System	<b>smartline*</b> , <b>blueline</b> (* available from August 2005 on)
Power Transmission	Torsionally resilient coupling
Gearbox Options	Reverse reduction gearbox, el. actuated, gearbox mounts, trolling mode for dead-slow propulsion, free auxiliary PTO, hydraulic pump drives

Power definition according ISO 3046  
 Intake air temperature 25°C / Sea water temperature 25°C  
 Intake air depression 15 mbar / Exhaust back pressure 30 mbar  
 Barometric pressure 1000 mbar  
 Power reduction at 45°C/32°C: none  
 All engines fulfil IMO emission regulation, certificate on request from April 2005 on  
 All engines EPA Tier 2 certification available from April 2005 on

## Dimensions and Masses (incl. gearbox)

Engine Model	8V2000	10V2000
Length [L] mm (in)	1895 (74.6)	2055 (81.0)
Width [W] mm (in)	1130 (44.5)	1130 (44.5)
Height [H] mm (in)	1200 (47.2)	1230 (48.4)
Mass [dry] kg (lbs)	2360 (5203)	2700 (5952)

Specifications are subject to change without notice.  
 All dimensions are approximate, for complete information refer to installation drawing.  
 For further information consult your MTU or Detroit Diesel distributor/dealer or any other authorized DaimlerChrysler representative.

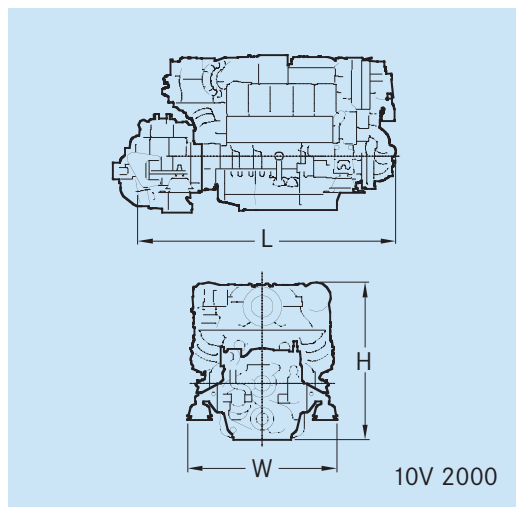

MTU Friedrichshafen GmbH  
 88040 Friedrichshafen  
 Germany  
 Phone +49 7541 90 29 98  
 Fax +49 7541 90 39 46  
 marine@mtu-online.com  
 www.mtu-online.com

MTU Detroit Diesel  
 13400 Outer Drive, West  
 Detroit, Michigan 48239-4001, USA  
 Phone +1 313 592 5124  
 Fax +1 313 592 5137  
 marine@detroitdiesel.com  
 www.mtudetroitdiesel.com

Your Contact:

# ANEXO 6.5.2

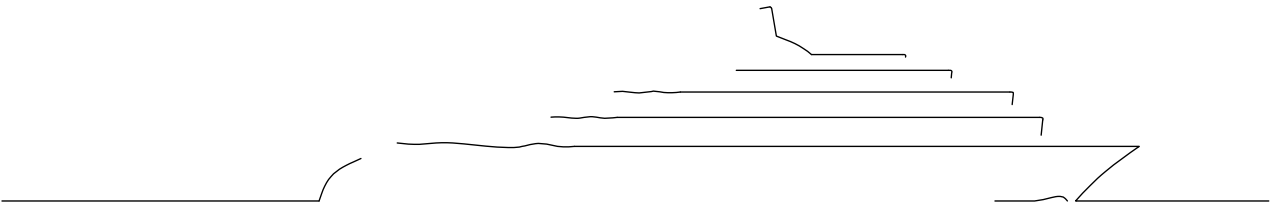

YATE DE 87m



Engine model		10V 2000 M93
Rated power to DIN ISO 3046		ICFN
Rated power max.	kW (bhp)	1120 (1502)
Speed max.	rpm	2450
Exhaust emission		54,18,34,39
Dimensions and masses without gearbox		
Length (L)	mm (in)	1545 (60,8)
Width (W)	mm (in)	1130 (44,5)
Height (H)	mm (in)	1230 (48,4)
Mass (dry)	kg (lbs)	2240.00 (4938.00)
Dimensions and masses with gearbox		
Length (L1)	mm (in)	2255 (88,8)
Width (W)	mm (in)	1130 (44,5)
Height (H1)	mm (in)	1230 (48,4)
Mass (dry)	kg (lbs)	2660 (5864)
Gearbox model		ZF 2050
Transmission ratio		on request
Engine main data		
Bore/Stroke	mm (in)	135/156 (5,3/6,1)
Cylinder displacement	l	2,23
Displacement, total	l (cu in)	22,3 (1361)
Intake air temperature	°C	25
Sea water temperature	°C	25
Site altitude above sea level	m	100
Barometric pressure	mbar	1000
Power reduction at 45/32 °C	%	0
Fuel consumption	l/h (gal/h)	287,7 (76,0)

## Legend

- 54 = EU Nonroad St IIIA (97/68/EC)
- 18 = IMO Tier II (Marpol Convention)
- 34 = EPA Marine T2 Comp (40 CFR 94)
- 39 = EU Marine (94/25/EC) Recreational Craft

# ANEXO 6.6.1

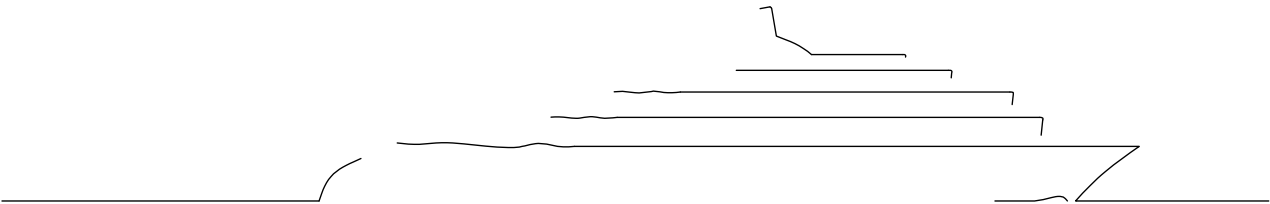

YATE DE 87m



# Propulsion

HydroComp NavCad 2014

Project ID **TFG\_Yate de lujo**  
 Description  
 File name **navcad cuaderno 6.hcnc**

## Analysis parameters

Hull-propulsor interaction		System analysis	
Technique:	[Calc] Prediction	Cavitation criteria:	Keller eqn
Prediction:	Holtrop	Analysis type:	Free run
Reference ship:		CPP method:	
Max prop diam:	2500,0 mm	Engine RPM:	
<b>Corrections</b>		Mass multiplier:	
Viscous scale corr:	[On] Custom	RPM constraint:	
Rudder location:	Behind propeller	Limit [RPM/s]:	
Friction line:	ITTC-57	<b>Water properties</b>	
Hull form factor:	1,283	Water type:	Salt
Corr allowance:	0,000374	Density:	1026,00 kg/m3
Roughness [mm]:	[On] 0,15	Viscosity:	1,18920e-6 m2/s
Ducted prop corr:	[Off]		
Tunnel stern corr:	[Off]		
Effective diam:			
Recess depth:			

## Prediction method check [Holtrop]

Parameters	FN [design]	CP	LWL/BWL	BWL/T
Value	0,28	0,58	5,91	3,10
Range	0,06-0,80	0,55-0,85	3,90-14,90	2,10-4,00

## Prediction results [System]

SPEED [kt]	HULL-PROPULSOR				ENGINE			
	PETOTAL [hp]	WFT	THD	EFFR	RPMENG [RPM]	PBPROP [hp]	FUEL [L/h]	LOADENG [%]
7,00	139,8	0,0941	0,1027	0,9739	418	108,0	---	7,2
8,00	203,7	0,0939	0,1027	0,9739	476	157,5	---	10,5
9,00	284,7	0,0937	0,1027	0,9739	534	220,4	---	14,7
10,00	387,0	0,0936	0,1027	0,9739	592	299,7	---	20,0
11,00	516,7	0,0934	0,1027	0,9739	652	400,2	---	26,7
12,00	682,0	0,0933	0,1027	0,9739	713	527,8	---	35,2
13,00	893,9	0,0932	0,1027	0,9739	776	691,0	---	46,1
14,00	1175,8	0,0931	0,1027	0,9739	843	907,6	---	60,5
+ 15,00 +	1533,0	0,0930	0,1027	0,9739	911	1181,9	---	78,8
16,00	1934,0	0,0929	0,1027	0,9739	979	1490,5	4,48	99,4
SPEED [kt]	POWER DELIVERY							
	RPMPROP [RPM]	QPROP [kN·m]	QENG [kN·m]	PDPPROP [hp]	PSPROP [hp]	PSTOTAL [hp]	PBTOTAL [hp]	TRANSP
7,00	64	11,18	1,70	102,6	104,7	209,5	215,9	516,7
8,00	72	14,32	2,18	149,7	152,7	305,5	314,9	404,9
9,00	81	17,86	2,72	209,5	213,7	427,5	440,7	325,5
10,00	90	21,90	3,34	284,9	290,7	581,5	599,5	265,9
11,00	99	26,56	4,05	380,4	388,2	776,4	800,4	219,1
12,00	109	32,03	4,88	501,7	512,0	1024,0	1055,6	181,2
13,00	118	38,53	5,87	656,9	670,3	1340,6	1382,1	149,9
14,00	128	46,60	7,10	862,7	880,3	1760,7	1815,1	122,9
+ 15,00 +	139	56,11	8,55	1123,5	1146,4	2292,8	2363,8	101,1
16,00	149	65,90	10,04	1416,8	1445,7	2891,5	2980,9	85,6
SPEED [kt]	EFFICIENCY				THRUST			
	EFFO	EFFG	EFFOA	MERIT	THRPROP [kN]	DELTHR [kN]		
7,00	0,7060	0,9700	0,6675	0,27667	16,13	28,95		
8,00	0,7053	0,9700	0,6667	0,27296	20,56	36,90		
9,00	0,7047	0,9700	0,6660	0,27019	25,55	45,85		
10,00	0,7044	0,9700	0,6656	0,26881	31,26	56,10		
11,00	0,7045	0,9700	0,6656	0,26923	37,94	68,09		
12,00	0,7050	0,9700	0,6660	0,27161	45,90	82,37		
13,00	0,7059	0,9700	0,6668	0,2761	55,54	99,67		
14,00	0,7072	0,9700	0,6678	0,28382	67,84	121,74		
+ 15,00 +	0,7081	0,9700	0,6686	0,29255	82,55	148,15		
16,00	0,7084	0,9700	0,6689	0,29838	97,63	175,21		



# Propulsion

HydroComp NavCad 2014

Project ID TFG\_Yate de lujo  
 Description  
 File name navcad cuaderno 6.hcnc

## Prediction results [Propulsor]

PROPULSOR COEFS									
SPEED [kt]	J	KT	KQ	KTJ2	KQJ3	CTH	CP	RNPROP	
7,00	0,8786	0,0931	0,01844	0,12061	0,027187	0,30712	0,44664	8,73e6	
8,00	0,8820	0,0915	0,01821	0,11763	0,026543	0,29954	0,43606	9,95e6	
9,00	0,8845	0,0903	0,01804	0,11545	0,026074	0,294	0,42835	1,12e7	
10,00	0,8858	0,0897	0,01796	0,11438	0,025843	0,29126	0,42455	1,24e7	
11,00	0,8854	0,0899	0,01798	0,1147	0,025912	0,29208	0,42569	1,36e7	
12,00	0,8832	0,0909	0,01813	0,11657	0,026314	0,29683	0,43229	1,49e7	
13,00	0,8792	0,0929	0,01841	0,12015	0,027087	0,30595	0,445	1,62e7	
14,00	0,8721	0,0962	0,01889	0,12651	0,028473	0,32216	0,46777	1,76e7	
+ 15,00 +	0,8639	0,1001	0,01943	0,13408	0,030138	0,34143	0,49512	1,90e7	
16,00	0,8584	0,1027	0,01980	0,13935	0,031308	0,35485	0,51434	2,04e7	
CAVITATION									
SPEED [kt]	SIGMAV	SIGMAN	SIGMA07R	TIPSPEED [m/s]	MINBAR	PRESS [kPa]	CAVAVG [%]	CAVMAX [%]	PITCHFC [mm]
7,00	24,05	18,57	3,31	11,66	0,066	2,85	2,0	2,0	3295,6
8,00	18,41	14,32	2,55	13,28	0,073	3,63	2,0	2,0	3303,1
9,00	14,54	11,37	2,02	14,90	0,081	4,51	2,0	2,0	3308,7
10,00	11,77	9,24	1,64	16,54	0,090	5,52	2,0	2,0	3311,5
11,00	9,73	7,62	1,36	18,20	0,100	6,70	2,0	2,0	3310,6
12,00	8,17	6,37	1,13	19,91	0,112	8,11	2,0	2,0	3305,8
13,00	6,96	5,38	0,96	21,67	0,128	9,81	2,0	2,0	3296,7
14,00	6,00	4,56	0,82	23,53	0,147	11,98	2,0	2,0	3281,0
+ 15,00 +	5,23	3,90	0,70	25,45	0,171	14,58	2,0	2,0	3263,0
16,00	4,59	3,38	0,61	27,32	0,194	17,25	2,0	2,0	3250,8

# Propulsion

HydroComp NavCad 2014

Project ID **TFG\_Yate de lujo**  
 Description  
 File name **navcad cuaderno 6.hcnc**

## Hull data

General		Planing	
Configuration:	<b>Monohull</b>	Proj chine length:	<b>0,000 m</b>
Chine type:	<b>Round/multiple</b>	Proj bottom area:	<b>0,0 m2</b>
Length on WL:	<b>78,860 m</b>	LCG fwd TR:	<b>[XCG/LP 0,000] 0,000 m</b>
Max beam on WL:	[LWL/BWL 5,907] <b>13,350 m</b>	VCG below WL:	<b>0,000 m</b>
Max molded draft:	[BWL/T 3,105] <b>4,300 m</b>	Aft station (fwd TR):	<b>0,000 m</b>
Displacement:	[CB 0,507] <b>2356,00 t</b>	Deadrise:	<b>0,00 deg</b>
Wetted surface:	[CS 2,817] <b>1198,9 m2</b>	Chine beam:	<b>0,000 m</b>
<b>ITTC-78 (CT)</b>		Chine ht below WL:	<b>0,000 m</b>
LCB fwd TR:	[XCB/LWL 0,504] <b>39,780 m</b>	Fwd station (fwd TR):	<b>0,000 m</b>
LCF fwd TR:	[XCF/LWL 0,425] <b>33,550 m</b>	Deadrise:	<b>0,00 deg</b>
Max section area:	[CX 0,880] <b>50,5 m2</b>	Chine beam:	<b>0,000 m</b>
Waterplane area:	[CWP 0,791] <b>832,9 m2</b>	Chine ht below WL:	<b>0,000 m</b>
Bulb section area:	<b>3,7 m2</b>	Propulsor type:	<b>Propeller</b>
Bulb ctr below WL:	<b>0,926 m</b>	Max prop diameter:	<b>2500,0 mm</b>
Bulb nose fwd TR:	<b>83,815 m</b>	Shaft angle to WL:	<b>4,00 deg</b>
Imm transom area:	[ATR/AX 0,131] <b>6,6 m2</b>	Position fwd TR:	<b>0,000 m</b>
Transom beam WL:	[BTR/BWL 1,000] <b>13,350 m</b>	Position below WL:	<b>0,000 m</b>
Transom immersion:	[TTR/T 0,116] <b>0,500 m</b>	Transom lift device:	<b>Flap</b>
Half entrance angle:	<b>31,00 deg</b>	Device count:	<b>0</b>
Bow shape factor:	[BTK flow] <b>-1,0</b>	Span:	<b>0,000 m</b>
Stern shape factor:	[AVG flow] <b>0,0</b>	Chord length:	<b>0,000 m</b>
		Deflection angle:	<b>0,00 deg</b>
		Tow point fwd TR:	<b>0,000 m</b>
		Tow point below WL:	<b>0,000 m</b>

## Propulsor data

Propulsor		Propeller options	
Count:	<b>2</b>	Oblique angle corr:	<b>On</b>
Propulsor type:	<b>Propeller series</b>	Shaft angle to WL:	<b>4,00 deg</b>
Propeller type:	<b>FPP</b>	Added rise of run:	<b>0,00 deg</b>
Propeller series:	<b>B Series</b>	Propeller cup:	<b>0,0 mm</b>
Propeller sizing:	<b>By power</b>	KTKQ corrections:	<b>Standard</b>
Reference prop:		Scale correction:	<b>Full ITTC</b>
Blade count:	<b>4</b>	KT multiplier:	<b>1,000</b>
Expanded area ratio:	<b>0,5883</b> [Size]	KQ multiplier:	<b>1,000</b>
Propeller diameter:	<b>3500,0 mm</b> [Keep]	Blade T/C [0.7R]:	<b>Standard</b>
Propeller mean pitch:	[P/D 0,9908] <b>3467,9 mm</b> [Keep]	Roughness:	<b>Standard</b>
Hub immersion:	<b>3150,0 mm</b>	Cav breakdown:	<b>Off</b>
<b>Engine/gear</b>		<b>Design condition</b>	
Engine data:	<b>MTU 10V 2000 M93</b>	Max prop diam:	<b>2500,0 mm</b>
Rated RPM:	<b>2450 RPM</b>	Design speed:	<b>15,00 kt</b>
Rated power:	<b>1500,0 hp</b>	Reference power:	<b>13410,0 hp</b>
Gear efficiency:	<b>0,970</b>	Design point:	<b>0,850</b>
Load correction:	<b>Off</b>	Reference RPM:	<b>1150,0</b>
Gear ratio:	<b>6,563</b> [Size]	Design point:	<b>1,050</b>
Shaft efficiency:	<b>0,980</b>		

# Propulsion

HydroComp NavCad 2014

Project ID    **TFG\_Yate de lujo**  
Description  
File name    **navcad cuaderno 6.hcnc**

## Symbols and values

SPEED = Vessel speed  
PETOTAL = Total vessel effective power  
WFT = Taylor wake fraction coefficient  
THD = Thrust deduction coefficient  
EFFR = Relative-rotative efficiency  
RPMENG = Engine RPM  
PBPROP = Brake power per propulsor  
FUEL = Fuel rate per engine  
LOADENG = Percentage of engine max available power at given RPM  
RPMPROP = Propulsor RPM  
QPROP = Propulsor open water torque  
QENG = Engine torque  
PDPROP = Delivered power per propulsor  
PSPROP = Shaft power per propulsor  
PSTOTAL = Total vessel shaft power  
PBTOTAL = Total vessel brake power  
TRANSP = Transport factor  
EFO = Propulsor open-water efficiency  
EFG = Gear efficiency (load corrected)  
EFOA = Overall propulsion efficiency [=PETOTAL/PSTOTAL]  
MERIT = Propulsor merit coefficient  
THRPROP = Open-water thrust per propulsor  
DELTHR = Total vessel delivered thrust  
J = Propulsor advance coefficient  
KT = Propulsor thrust coefficient [horizontal, if in oblique flow]  
KQ = Propulsor torque coefficient  
KTJ2 = Propulsor thrust loading ratio  
KQJ3 = Propulsor torque loading ratio  
CTH = Horizontal component of bare-hull resistance coefficient  
CP = Propulsor thrust loading coefficient  
RNPROP = Propeller Reynolds number at 0.7R  
SIGMAV = Cavitation number of propeller by vessel speed  
SIGMAN = Cavitation number of propeller by RPM  
SIGMA07R = Cavitation number of blade section at 0.7R  
TIPSPEED = Propeller circumferential tip speed  
MINBAR = Minimum expanded blade area ratio recommended by selected cavitation criteria  
PRESS = Average propeller loading pressure  
CAVAVG = Average predicted back cavitation percentage  
CAVMAX = Peak predicted back cavitation percentage [if in oblique flow]  
PITCHFC = Minimum recommended pitch to avoid face cavitation  
+ = Design speed indicator  
\* = Exceeds recommended parameter limit  
! = Exceeds recommended cavitation criteria [warning]  
!! = Substantially exceeds recommended cavitation criteria [critical]  
!!! = Thrust breakdown is indicated [severe]  
--- = Insignificant or not applicable

# ANEXO 6.6.2

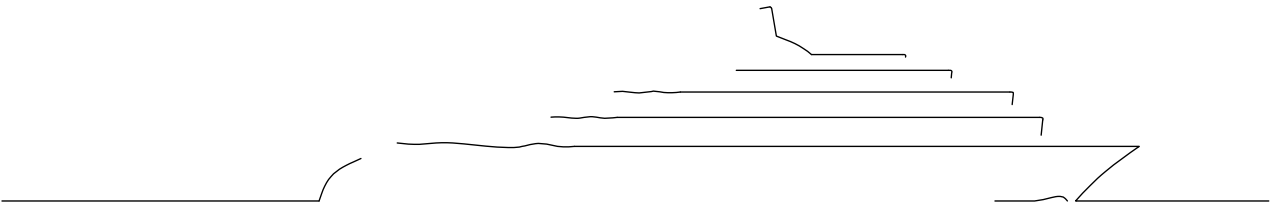

YATE DE 87m

# Propulsion

HydroComp NavCad 2014

Project ID **TFG\_Yate de lujo**  
 Description  
 File name **navcad cuaderno 6.hcnc**

## Analysis parameters

Hull-propulsor interaction		System analysis	
Technique:	[Calc] Prediction	Cavitation criteria:	Keller eqn
Prediction:	Holtrop	Analysis type:	Free run
Reference ship:		CPP method:	
Max prop diam:	2500,0 mm	Engine RPM:	
<b>Corrections</b>		Mass multiplier:	
Viscous scale corr:	[On] Custom	RPM constraint:	
Rudder location:	Behind propeller	Limit [RPM/s]:	
Friction line:	ITTC-57	<b>Water properties</b>	
Hull form factor:	1,283	Water type:	Salt
Corr allowance:	0,000374	Density:	1026,00 kg/m3
Roughness [mm]:	[On] 0,15	Viscosity:	1,18920e-6 m2/s
Ducted prop corr:	[Off]		
Tunnel stern corr:	[Off]		
Effective diam:			
Recess depth:	λ		

## Prediction method check [Holtrop]

Parameters	FN [design]	CP	LWL/BWL	BWL/T
Value	0,28	0,58	5,91	3,10
Range	0,06-0,80	0,55-0,85	3,90-14,90	2,10-4,00

## Prediction results [System]

SPEED [kt]	HULL-PROPULSOR				ENGINE			
	PETOTAL [hp]	WFT	THD	EFFR	RPMENG [RPM]	PBPROP [hp]	FUEL [L/h]	LOADENG [%]
7,00	139,8	0,0941	0,1027	0,9739	413	107,0	---	7,1
8,00	203,7	0,0939	0,1027	0,9739	470	156,1	---	10,4
9,00	284,7	0,0937	0,1027	0,9739	528	218,4	---	14,6
10,00	387,0	0,0936	0,1027	0,9739	585	297,2	---	19,8
11,00	516,7	0,0934	0,1027	0,9739	644	396,8	---	26,5
12,00	682,0	0,0933	0,1027	0,9739	705	523,2	---	34,9
13,00	893,9	0,0932	0,1027	0,9739	767	684,8	---	45,7
14,00	1175,8	0,0931	0,1027	0,9739	832	898,8	---	59,9
+ 15,00 +	1533,0	0,0930	0,1027	0,9739	900	1169,7	---	78,0
16,00	1934,0	0,0929	0,1027	0,9739	966	1474,3	---	98,3
SPEED [kt]	POWER DELIVERY							
	RPMPROP [RPM]	QPROP [kN·m]	QENG [kN·m]	PDPPROP [hp]	PSPROP [hp]	PSTOTAL [hp]	PBTOTAL [hp]	TRANSP
7,00	63	11,21	1,71	101,7	103,8	207,5	214,0	521,5
8,00	72	14,36	2,19	148,4	151,4	302,8	312,1	408,5
9,00	80	17,92	2,73	207,7	211,9	423,8	436,9	328,3
10,00	89	21,96	3,35	282,5	288,3	576,5	594,3	268,2
11,00	98	26,64	4,06	377,2	384,9	769,7	793,5	221,0
12,00	107	32,12	4,89	497,4	507,5	1015,0	1046,4	182,8
13,00	117	38,63	5,89	650,9	664,2	1328,4	1369,5	151,3
14,00	127	46,72	7,12	854,4	871,8	1743,6	1797,6	124,1
+ 15,00 +	137	56,23	8,57	1111,9	1134,6	2269,1	2339,3	102,2
16,00	147	66,04	10,06	1401,5	1430,1	2860,2	2948,7	86,5
SPEED [kt]	EFFICIENCY				THRUST			
	EFFO	EFFG	EFFOA	MERIT	THRPROP [kN]	DELTHR [kN]		
7,00	0,7125	0,9700	0,6736	0,27922	16,13	28,95		
8,00	0,7116	0,9700	0,6726	0,2754	20,56	36,90		
9,00	0,7109	0,9700	0,6718	0,27255	25,55	45,85		
10,00	0,7105	0,9700	0,6713	0,27113	31,26	56,10		
11,00	0,7106	0,9700	0,6713	0,27155	37,94	68,09		
12,00	0,7113	0,9700	0,6719	0,27401	45,90	82,38		
13,00	0,7124	0,9700	0,6729	0,27864	55,54	99,67		
14,00	0,7141	0,9700	0,6744	0,28659	67,84	121,74		
+ 15,00 +	0,7155	0,9700	0,6756	0,29561	82,55	148,15		
16,00	0,7161	0,9700	0,6762	0,30164	97,63	175,21		





# Propulsion

HydroComp NavCad 2014

Project ID TFG\_Yate de lujo  
 Description  
 File name navcad cuaderno 6.hcnc

## Prediction results [Propulsor]

PROPULSOR COEFS									
SPEED [kt]	J	KT	KQ	KTJ2	KQJ3	CTH	CP	RNPROP	
7,00	0,8892	0,0954	0,01894	0,1206	0,026938	0,30712	0,44255	6,91e6	
8,00	0,8925	0,0937	0,01870	0,11763	0,026309	0,29955	0,43221	7,87e6	
9,00	0,8949	0,0925	0,01852	0,11545	0,025849	0,294	0,42465	8,84e6	
10,00	0,8961	0,0918	0,01844	0,11438	0,025622	0,29126	0,42093	9,81e6	
11,00	0,8957	0,0920	0,01846	0,1147	0,02569	0,29208	0,42204	1,08e7	
12,00	0,8936	0,0931	0,01862	0,11657	0,026084	0,29684	0,42851	1,18e7	
13,00	0,8897	0,0951	0,01890	0,12015	0,026841	0,30595	0,44095	1,28e7	
14,00	0,8829	0,0986	0,01940	0,12651	0,028198	0,32216	0,46324	1,39e7	
+ 15,00 +	0,8750	0,1026	0,01998	0,13408	0,029826	0,34143	0,49	1,50e7	
16,00	0,8696	0,1054	0,02037	0,13935	0,03097	0,35485	0,50878	1,61e7	
CAVITATION									
SPEED [kt]	SIGMAV	SIGMAN	SIGMA07R	TIPSPEED [m/s]	MINBAR	PRESS [kPa]	CAVAVG [%]	CAVMAX [%]	PITCHFC [mm]
7,00	24,05	19,02	3,38	11,53	0,069	2,85	2,0	2,0	3335,2
8,00	18,41	14,66	2,60	13,13	0,076	3,63	2,0	2,0	3342,3
9,00	14,54	11,64	2,07	14,73	0,085	4,51	2,0	2,0	3347,5
10,00	11,77	9,45	1,68	16,35	0,095	5,52	2,0	2,0	3350,1
11,00	9,73	7,80	1,38	17,99	0,106	6,70	2,0	2,0	3349,3
12,00	8,17	6,53	1,16	19,68	0,120	8,11	2,0	2,0	3344,8
13,00	6,96	5,51	0,98	21,41	0,137	9,81	2,0	2,0	3336,3
14,00	6,00	4,68	0,83	23,24	0,159	11,98	2,0	2,0	3321,6
+ 15,00 +	5,23	4,00	0,71	25,13	0,185	14,58	2,0	2,0	3304,6
16,00	4,59	3,47	0,62	26,97	0,212	17,25	2,0	2,0	3293,2

# Propulsion

HydroComp NavCad 2014

Project ID **TFG\_Yate de lujo**  
 Description  
 File name **navcad cuaderno 6.hcnc**

## Hull data

General		Planing	
Configuration:	<b>Monohull</b>	<i>Proj chine length:</i>	<b>0,000 m</b>
Chine type:	<b>Round/multiple</b>	<i>Proj bottom area:</i>	<b>0,0 m2</b>
Length on WL:	<b>78,860 m</b>	<i>LCG fwd TR:</i>	<b>[XCG/LP 0,000] 0,000 m</b>
Max beam on WL:	[LWL/BWL 5,907] <b>13,350 m</b>	<i>VCG below WL:</i>	<b>0,000 m</b>
Max molded draft:	[BWL/T 3,105] <b>4,300 m</b>	<i>Aft station (fwd TR):</i>	<b>0,000 m</b>
Displacement:	[CB 0,507] <b>2356,00 t</b>	<i>Deadrise:</i>	<b>0,00 deg</b>
Wetted surface:	[CS 2,817] <b>1198,9 m2</b>	<i>Chine beam:</i>	<b>0,000 m</b>
<b>ITTC-78 (CT)</b>		<i>Chine ht below WL:</i>	<b>0,000 m</b>
LCB fwd TR:	[XCB/LWL 0,504] <b>39,780 m</b>	<i>Fwd station (fwd TR):</i>	<b>0,000 m</b>
LCF fwd TR:	[XCF/LWL 0,425] <b>33,550 m</b>	<i>Deadrise:</i>	<b>0,00 deg</b>
Max section area:	[CX 0,880] <b>50,5 m2</b>	<i>Chine beam:</i>	<b>0,000 m</b>
Waterplane area:	[CWP 0,791] <b>832,9 m2</b>	<i>Chine ht below WL:</i>	<b>0,000 m</b>
Bulb section area:	<b>3,7 m2</b>	<i>Propulsor type:</i>	<b>Propeller</b>
Bulb ctr below WL:	<b>0,926 m</b>	<i>Max prop diameter:</i>	<b>2500,0 mm</b>
Bulb nose fwd TR:	<b>83,815 m</b>	<i>Shaft angle to WL:</i>	<b>4,00 deg</b>
Imm transom area:	[ATR/AX 0,131] <b>6,6 m2</b>	<i>Position fwd TR:</i>	<b>0,000 m</b>
Transom beam WL:	[BTR/BWL 1,000] <b>13,350 m</b>	<i>Position below WL:</i>	<b>0,000 m</b>
Transom immersion:	[TTR/T 0,116] <b>0,500 m</b>	<i>Transom lift device:</i>	<b>Flap</b>
Half entrance angle:	<b>31,00 deg</b>	<i>Device count:</i>	<b>0</b>
Bow shape factor:	[BTK flow] <b>-1,0</b>	<i>Span:</i>	<b>0,000 m</b>
Stern shape factor:	[AVG flow] <b>0,0</b>	<i>Chord length:</i>	<b>0,000 m</b>
		<i>Deflection angle:</i>	<b>0,00 deg</b>
		<i>Tow point fwd TR:</i>	<b>0,000 m</b>
		<i>Tow point below WL:</i>	<b>0,000 m</b>

## Propulsor data

Propulsor		Propeller options	
Count:	<b>2</b>	<i>Oblique angle corr:</i>	<b>On</b>
Propulsor type:	<b>Propeller series</b>	<i>Shaft angle to WL:</i>	<b>4,00 deg</b>
Propeller type:	<b>FPP</b>	<i>Added rise of run:</i>	<b>0,00 deg</b>
Propeller series:	<b>B Series</b>	<i>Propeller cup:</i>	<b>0,0 mm</b>
Propeller sizing:	<b>By power</b>	<i>KTKQ corrections:</i>	<b>Standard</b>
Reference prop:		<i>Scale correction:</i>	<b>Full ITTC</b>
Blade count:	<b>5</b>	<i>KT multiplier:</i>	<b>1,000</b>
Expanded area ratio:	<b>0,5883</b> [Size]	<i>KQ multiplier:</i>	<b>1,000</b>
Propeller diameter:	<b>3500,0 mm</b> [Keep]	<i>Blade T/C [0.7R]:</i>	<b>Standard</b>
Propeller mean pitch:	[P/D 0,9908] <b>3467,9 mm</b> [Keep]	<i>Roughness:</i>	<b>Standard</b>
Hub immersion:	<b>3150,0 mm</b>	<i>Cav breakdown:</i>	<b>Off</b>
<b>Engine/gear</b>		<b>Design condition</b>	
Engine data:	<b>MTU 10V 2000 M93</b>	<i>Max prop diam:</i>	<b>2500,0 mm</b>
Rated RPM:	<b>2450 RPM</b>	<i>Design speed:</i>	<b>15,00 kt</b>
Rated power:	<b>1500,0 hp</b>	<i>Reference power:</i>	<b>13410,0 hp</b>
Gear efficiency:	<b>0,970</b>	<i>Design point:</i>	<b>0,850</b>
Load correction:	<b>Off</b>	<i>Reference RPM:</i>	<b>1150,0</b>
Gear ratio:	<b>6,563</b> [Size]	<i>Design point:</i>	<b>1,050</b>
Shaft efficiency:	<b>0,980</b>		

# Propulsion

HydroComp NavCad 2014

Project ID    **TFG\_Yate de lujo**  
Description  
File name    **navcad cuaderno 6.hcnc**

## Symbols and values

SPEED = Vessel speed  
PETOTAL = Total vessel effective power  
WFT = Taylor wake fraction coefficient  
THD = Thrust deduction coefficient  
EFFR = Relative-rotative efficiency  
RPMENG = Engine RPM  
PBPROP = Brake power per propulsor  
FUEL = Fuel rate per engine  
LOADENG = Percentage of engine max available power at given RPM  
RPMPROP = Propulsor RPM  
QPROP = Propulsor open water torque  
QENG = Engine torque  
PDPROP = Delivered power per propulsor  
PSPROP = Shaft power per propulsor  
PSTOTAL = Total vessel shaft power  
PBTOTAL = Total vessel brake power  
TRANSP = Transport factor  
EFO = Propulsor open-water efficiency  
EFG = Gear efficiency (load corrected)  
EFOA = Overall propulsion efficiency [=PETOTAL/PSTOTAL]  
MERIT = Propulsor merit coefficient  
THRPROP = Open-water thrust per propulsor  
DELTHR = Total vessel delivered thrust  
J = Propulsor advance coefficient  
KT = Propulsor thrust coefficient [horizontal, if in oblique flow]  
KQ = Propulsor torque coefficient  
KTJ2 = Propulsor thrust loading ratio  
KQJ3 = Propulsor torque loading ratio  
CTH = Horizontal component of bare-hull resistance coefficient  
CP = Propulsor thrust loading coefficient  
RNPROP = Propeller Reynolds number at 0.7R  
SIGMAV = Cavitation number of propeller by vessel speed  
SIGMAN = Cavitation number of propeller by RPM  
SIGMA07R = Cavitation number of blade section at 0.7R  
TIPSPEED = Propeller circumferential tip speed  
MINBAR = Minimum expanded blade area ratio recommended by selected cavitation criteria  
PRESS = Average propeller loading pressure  
CAVAVG = Average predicted back cavitation percentage  
CAVMAX = Peak predicted back cavitation percentage [if in oblique flow]  
PITCHFC = Minimum recommended pitch to avoid face cavitation  
+ = Design speed indicator  
\* = Exceeds recommended parameter limit  
! = Exceeds recommended cavitation criteria [warning]  
!! = Substantially exceeds recommended cavitation criteria [critical]  
!!! = Thrust breakdown is indicated [severe]  
--- = Insignificant or not applicable

# ANEXO 6.6.3

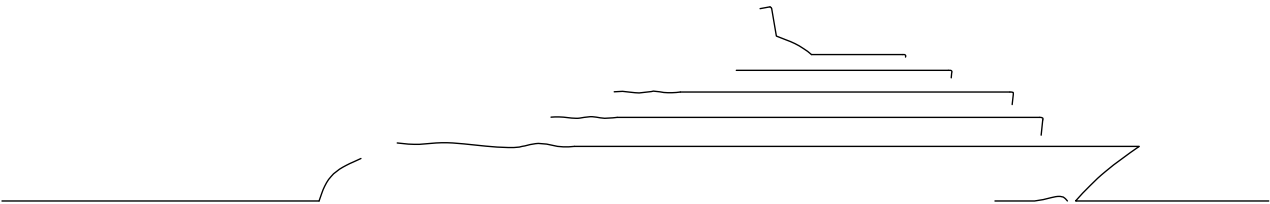

YATE DE 87m

# Propulsion

HydroComp NavCad 2014

Project ID **TFG\_Yate de lujo**  
 Description  
 File name **navcad cuaderno 6.hcnc**

## Analysis parameters

Hull-propulsor interaction		System analysis	
Technique:	[Calc] Prediction	Cavitation criteria:	Keller eqn
Prediction:	Holtrop	Analysis type:	Free run
Reference ship:		CPP method:	
Max prop diam:	2500,0 mm	Engine RPM:	
<b>Corrections</b>		Mass multiplier:	
Viscous scale corr:	[On] Custom	RPM constraint:	
Rudder location:	Behind propeller	Limit [RPM/s]:	
Friction line:	ITTC-57	<b>Water properties</b>	
Hull form factor:	1,283	Water type:	Salt
Corr allowance:	0,000374	Density:	1026,00 kg/m3
Roughness [mm]:	[On] 0,15	Viscosity:	1,18920e-6 m2/s
Ducted prop corr:	[Off]		
Tunnel stern corr:	[Off]		
Effective diam:			
Recess depth:			

## Prediction method check [Holtrop]

Parameters	FN [design]	CP	LWL/BWL	BWL/T
Value	0,28	0,58	5,91	3,10
Range	0,06-0,80	0,55-0,85	3,90-14,90	2,10-4,00

## Prediction results [System]

SPEED [kt]	HULL-PROPULSOR				ENGINE			
	PETOTAL [hp]	WFT	THD	EFFR	RPMENG [RPM]	PBPROP [hp]	FUEL [L/h]	LOADENG [%]
7,00	139,8	0,0941	0,1027	0,9739	411	106,9	---	7,1
8,00	203,7	0,0939	0,1027	0,9739	469	156,0	---	10,4
9,00	284,7	0,0937	0,1027	0,9739	526	218,4	---	14,6
10,00	387,0	0,0936	0,1027	0,9739	584	297,2	---	19,8
11,00	516,7	0,0934	0,1027	0,9739	643	396,7	---	26,4
12,00	682,0	0,0933	0,1027	0,9739	703	523,1	---	34,9
13,00	893,9	0,0932	0,1027	0,9739	764	684,3	---	45,6
14,00	1175,8	0,0931	0,1027	0,9739	829	897,5	---	59,8
+ 15,00 +	1533,0	0,0930	0,1027	0,9739	896	1167,1	---	77,8
16,00	1934,0	0,0929	0,1027	0,9739	962	1470,3	---	98,0
SPEED [kt]	POWER DELIVERY							
	RPMPROP [RPM]	QPROP [kN·m]	QENG [kN·m]	PDPROP [hp]	PSPROP [hp]	PSTOTAL [hp]	PBTOTAL [hp]	TRANSP
7,00	63	11,24	1,71	101,6	103,7	207,4	213,8	521,8
8,00	71	14,40	2,19	148,3	151,3	302,7	312,0	408,7
9,00	80	17,97	2,74	207,6	211,9	423,7	436,9	328,4
10,00	89	22,03	3,36	282,5	288,3	576,5	594,4	268,2
11,00	98	26,72	4,07	377,1	384,8	769,7	793,5	221,0
12,00	107	32,21	4,91	497,2	507,4	1014,8	1046,1	182,8
13,00	116	38,74	5,90	650,5	663,8	1327,6	1368,6	151,4
14,00	126	46,83	7,14	853,2	870,6	1741,2	1795,1	124,3
+ 15,00 +	137	56,35	8,59	1109,4	1132,1	2264,2	2334,2	102,4
16,00	147	66,16	10,08	1397,7	1426,2	2852,4	2940,7	86,7
SPEED [kt]	EFFICIENCY				THRUST			
	EFFO	EFFG	EFFOA	MERIT	THRPROP [kN]	DELTHR [kN]		
7,00	0,7131	0,9700	0,6741	0,27942	16,13	28,95		
8,00	0,7119	0,9700	0,6729	0,2755	20,56	36,90		
9,00	0,7110	0,9700	0,6719	0,27259	25,55	45,85		
10,00	0,7105	0,9700	0,6713	0,27112	31,26	56,10		
11,00	0,7106	0,9700	0,6713	0,27156	37,94	68,09		
12,00	0,7114	0,9700	0,6720	0,27408	45,90	82,38		
13,00	0,7129	0,9700	0,6733	0,27882	55,54	99,67		
14,00	0,7150	0,9700	0,6753	0,28698	67,83	121,74		
+ 15,00 +	0,7170	0,9700	0,6771	0,29626	82,55	148,15		
16,00	0,7181	0,9700	0,6780	0,30246	97,63	175,21		



# Propulsion

HydroComp NavCad 2014

Project ID TFG\_Yate de lujo  
 Description  
 File name navcad cuaderno 6.hcnc

## Prediction results [Propulsor]

PROPULSOR COEFS									
SPEED [kt]	J	KT	KQ	KTJ2	KQJ3	CTH	CP	RNPROP	
7,00	0,8922	0,0960	0,01912	0,1206	0,026919	0,30711	0,44223	5,74e6	
8,00	0,8952	0,0943	0,01887	0,11763	0,026299	0,29955	0,43205	6,54e6	
9,00	0,8975	0,0930	0,01869	0,11546	0,025846	0,29401	0,42461	7,35e6	
10,00	0,8987	0,0924	0,01860	0,11438	0,025622	0,29126	0,42093	8,16e6	
11,00	0,8983	0,0926	0,01862	0,1147	0,025689	0,29208	0,42203	8,98e6	
12,00	0,8964	0,0937	0,01878	0,11657	0,026077	0,29683	0,4284	9,81e6	
13,00	0,8926	0,0957	0,01908	0,12015	0,026823	0,30595	0,44066	1,07e7	
14,00	0,8861	0,0993	0,01959	0,12651	0,028159	0,32216	0,46261	1,16e7	
+ 15,00 +	0,8786	0,1035	0,02019	0,13408	0,029761	0,34143	0,48893	1,25e7	
16,00	0,8735	0,1063	0,02059	0,13935	0,030886	0,35485	0,5074	1,34e7	
CAVITATION									
SPEED [kt]	SIGMAV	SIGMAN	SIGMA07R	TIPSPEED [m/s]	MINBAR	PRESS [kPa]	CAVAVG [%]	CAVMAX [%]	PITCHFC [mm]
7,00	24,05	19,15	3,40	11,49	0,072	2,85	2,0	2,0	3346,3
8,00	18,41	14,75	2,62	13,09	0,080	3,63	2,0	2,0	3352,7
9,00	14,54	11,71	2,08	14,69	0,089	4,51	2,0	2,0	3357,4
10,00	11,77	9,51	1,68	16,30	0,100	5,52	2,0	2,0	3359,7
11,00	9,73	7,85	1,39	17,94	0,113	6,70	2,0	2,0	3359,0
12,00	8,17	6,57	1,16	19,62	0,129	8,11	2,0	2,0	3355,0
13,00	6,96	5,55	0,98	21,34	0,148	9,81	2,0	2,0	3347,3
14,00	6,00	4,71	0,84	23,16	0,172	11,98	2,0	2,0	3333,9
+ 15,00 +	5,23	4,03	0,72	25,02	0,200	14,58	2,0	2,0	3318,5
16,00	4,59	3,50	0,63	26,85	0,230	17,25	2,0	2,0	3308,0

# Propulsion

HydroComp NavCad 2014

Project ID **TFG\_Yate de lujo**  
 Description  
 File name **navcad cuaderno 6.hcnc**

## Hull data

General		Planing	
Configuration:	<b>Monohull</b>	<i>Proj chine length:</i>	<b>0,000 m</b>
Chine type:	<b>Round/multiple</b>	<i>Proj bottom area:</i>	<b>0,0 m2</b>
Length on WL:	<b>78,860 m</b>	<i>LCG fwd TR:</i>	<b>[XCG/LP 0,000] 0,000 m</b>
Max beam on WL:	[LWL/BWL 5,907] <b>13,350 m</b>	<i>VCG below WL:</i>	<b>0,000 m</b>
Max molded draft:	[BWL/T 3,105] <b>4,300 m</b>	<i>Aft station (fwd TR):</i>	<b>0,000 m</b>
Displacement:	[CB 0,507] <b>2356,00 t</b>	<i>Deadrise:</i>	<b>0,00 deg</b>
Wetted surface:	[CS 2,817] <b>1198,9 m2</b>	<i>Chine beam:</i>	<b>0,000 m</b>
<b>ITTC-78 (CT)</b>		<i>Chine ht below WL:</i>	<b>0,000 m</b>
LCB fwd TR:	[XCB/LWL 0,504] <b>39,780 m</b>	<i>Fwd station (fwd TR):</i>	<b>0,000 m</b>
LCF fwd TR:	[XCF/LWL 0,425] <b>33,550 m</b>	<i>Deadrise:</i>	<b>0,00 deg</b>
Max section area:	[CX 0,880] <b>50,5 m2</b>	<i>Chine beam:</i>	<b>0,000 m</b>
Waterplane area:	[CWP 0,791] <b>832,9 m2</b>	<i>Chine ht below WL:</i>	<b>0,000 m</b>
Bulb section area:	<b>3,7 m2</b>	<i>Propulsor type:</i>	<b>Propeller</b>
Bulb ctr below WL:	<b>0,926 m</b>	<i>Max prop diameter:</i>	<b>2500,0 mm</b>
Bulb nose fwd TR:	<b>83,815 m</b>	<i>Shaft angle to WL:</i>	<b>4,00 deg</b>
Imm transom area:	[ATR/AX 0,131] <b>6,6 m2</b>	<i>Position fwd TR:</i>	<b>0,000 m</b>
Transom beam WL:	[BTR/BWL 1,000] <b>13,350 m</b>	<i>Position below WL:</i>	<b>0,000 m</b>
Transom immersion:	[TTR/T 0,116] <b>0,500 m</b>	<i>Transom lift device:</i>	<b>Flap</b>
Half entrance angle:	<b>31,00 deg</b>	<i>Device count:</i>	<b>0</b>
Bow shape factor:	[BTK flow] <b>-1,0</b>	<i>Span:</i>	<b>0,000 m</b>
Stern shape factor:	[AVG flow] <b>0,0</b>	<i>Chord length:</i>	<b>0,000 m</b>
		<i>Deflection angle:</i>	<b>0,00 deg</b>
		<i>Tow point fwd TR:</i>	<b>0,000 m</b>
		<i>Tow point below WL:</i>	<b>0,000 m</b>

## Propulsor data

Propulsor		Propeller options	
Count:	<b>2</b>	Oblique angle corr:	<b>On</b>
Propulsor type:	<b>Propeller series</b>	Shaft angle to WL:	<b>4,00 deg</b>
Propeller type:	<b>FPP</b>	Added rise of run:	<b>0,00 deg</b>
Propeller series:	<b>B Series</b>	Propeller cup:	<b>0,0 mm</b>
Propeller sizing:	<b>By power</b>	KTKQ corrections:	<b>Standard</b>
Reference prop:		Scale correction:	<b>Full ITTC</b>
Blade count:	<b>6</b>	KT multiplier:	<b>1,000</b>
Expanded area ratio:	<b>0,5883</b> [Size]	KQ multiplier:	<b>1,000</b>
Propeller diameter:	<b>3500,0 mm</b> [Keep]	Blade T/C [0.7R]:	<b>Standard</b>
Propeller mean pitch:	[P/D 0,9908] <b>3467,9 mm</b> [Keep]	Roughness:	<b>Standard</b>
Hub immersion:	<b>3150,0 mm</b>	Cav breakdown:	<b>Off</b>
<b>Engine/gear</b>		<b>Design condition</b>	
Engine data:	<b>MTU 10V 2000 M93</b>	Max prop diam:	<b>2500,0 mm</b>
Rated RPM:	<b>2450 RPM</b>	Design speed:	<b>15,00 kt</b>
Rated power:	<b>1500,0 hp</b>	Reference power:	<b>13410,0 hp</b>
Gear efficiency:	<b>0,970</b>	Design point:	<b>0,850</b>
Load correction:	<b>Off</b>	Reference RPM:	<b>1150,0</b>
Gear ratio:	<b>6,563</b> [Size]	Design point:	<b>1,050</b>
Shaft efficiency:	<b>0,980</b>		



# Propulsion

HydroComp NavCad 2014

Project ID    **TFG\_Yate de lujo**  
Description  
File name    **navcad cuaderno 6.hcnc**

## Symbols and values

SPEED = Vessel speed  
PETOTAL = Total vessel effective power  
WFT = Taylor wake fraction coefficient  
THD = Thrust deduction coefficient  
EFFR = Relative-rotative efficiency  
RPMENG = Engine RPM  
PBPROP = Brake power per propulsor  
FUEL = Fuel rate per engine  
LOADENG = Percentage of engine max available power at given RPM  
RPMPROP = Propulsor RPM  
QPROP = Propulsor open water torque  
QENG = Engine torque  
PDPROP = Delivered power per propulsor  
PSPROP = Shaft power per propulsor  
PSTOTAL = Total vessel shaft power  
PBTOTAL = Total vessel brake power  
TRANSP = Transport factor  
EFO = Propulsor open-water efficiency  
EFG = Gear efficiency (load corrected)  
EFOA = Overall propulsion efficiency [=PETOTAL/PSTOTAL]  
MERIT = Propulsor merit coefficient  
THRPROP = Open-water thrust per propulsor  
DELTHR = Total vessel delivered thrust  
J = Propulsor advance coefficient  
KT = Propulsor thrust coefficient [horizontal, if in oblique flow]  
KQ = Propulsor torque coefficient  
KTJ2 = Propulsor thrust loading ratio  
KQJ3 = Propulsor torque loading ratio  
CTH = Horizontal component of bare-hull resistance coefficient  
CP = Propulsor thrust loading coefficient  
RNPROP = Propeller Reynolds number at 0.7R  
SIGMAV = Cavitation number of propeller by vessel speed  
SIGMAN = Cavitation number of propeller by RPM  
SIGMA07R = Cavitation number of blade section at 0.7R  
TIPSPEED = Propeller circumferential tip speed  
MINBAR = Minimum expanded blade area ratio recommended by selected cavitation criteria  
PRESS = Average propeller loading pressure  
CAVAVG = Average predicted back cavitation percentage  
CAVMAX = Peak predicted back cavitation percentage [if in oblique flow]  
PITCHFC = Minimum recommended pitch to avoid face cavitation  
+ = Design speed indicator  
\* = Exceeds recommended parameter limit  
! = Exceeds recommended cavitation criteria [warning]  
!! = Substantially exceeds recommended cavitation criteria [critical]  
!!! = Thrust breakdown is indicated [severe]  
--- = Insignificant or not applicable

# ANEXO 6.7.3

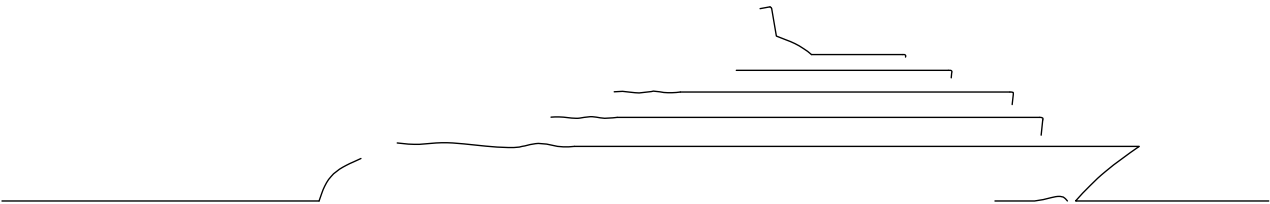

YATE DE 87m

## THE RUDDER



In the previous article on maneuverability, I pointed out to the fact that the

maneuvering qualities of a ship, as well as her various characteristics, depend mostly on the rudder's type and size.

For that reason, starting from the requirements supplied by the customer, the designer must obtain the rudder's characteristics that satisfy such requirements. Subsequently, from such characteristics he must define the dimensions that affect, on one hand, the structural size of the rudder and, on the other hand, the power of the system that will drive it. The two problems related to rudder design involve a quite ample field of ship hydrodynamics, which could be briefly synthesized with the expression "the rudder hydrodynamic design". The precise definition and the subsequent analysis of the factors that have to be considered require quite an exhaustive study thus, for a magazine article, a synthesis is necessary.

The problems concerning rudder design have been treated simultaneously by experts in aerodynamics and experts in hydrodynamics. Therefore, the naval architect may use such research studies to develop a good design. One of the major and most useful data for rudder design is the radius of evolution of the ship, which influences the rudder area on the basis of the ship's hull characteristics. After defining the rudder area to be used, shape, size, dimensions and suitable location must be fixed in order to obtain the most acceptable hydrodynamic compromise. Rudder area means the area of the symmetry plane of just one of its sides. Even though it is very difficult to relate the forces and the moments generated by the rudder to the ship's maneuverability characteristics, the knowledge of such data is essential for design, because the rudder thickness, the rudder shaft diameter and the steering gear size - the system needed to move it - depend on them.

Figure 1

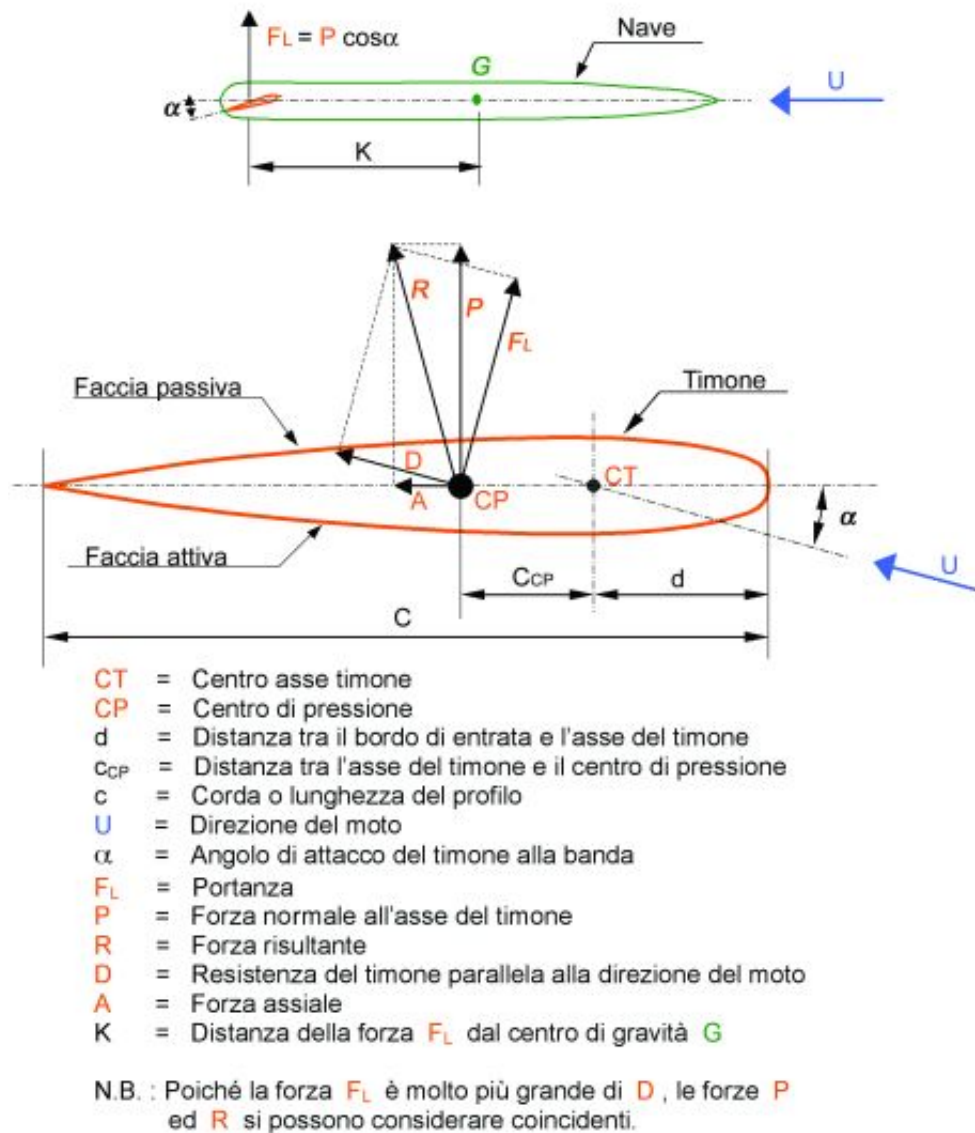
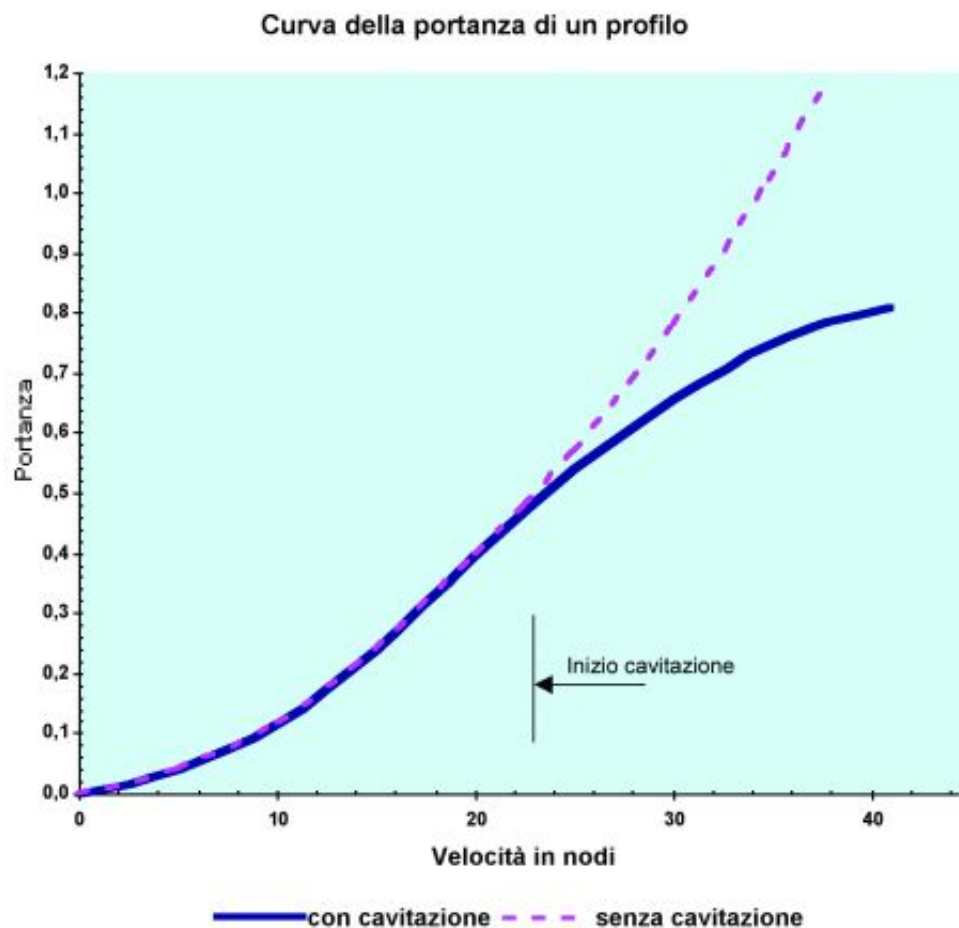

Figure 1 shows the involved forces that must be taken into consideration for rudder design. Among the most widely known profiles, the most suitable for rudder construction are the so-called wing profiles with the rudder shaft in the symmetry plane. A profile of this type, immersed in a fluid having speed  $U$  and angle of attack  $\alpha$  as shown in Figure 1, creates dissymmetry as for speed: speed on the rudder's left side (passive surface) increases and on the rudder's right side (active surface) decreases. According to Bernoulli's Law, this generates a pressure decrease on the left side and an increase on the right side. The resulting pressure difference is the rudder force that, in this case, is directed from right to left. Usually such force is resolved into two components: force  $F_L$  perpendicular to the direction of speed  $U$ , and force  $D$ , having the same direction as  $U$  (see Figure 1).

The creation of the perpendicular component  $F_L$  is, in fact, the only purpose of the rudder's existence. The product of force  $P$  by distance  $c_{CP}$  (see Figure 1) between its point of application and the rudder shaft generates a twisting moment, while the

product of such force  $P$  for the vertical distance between its point of application and the load-carrying bearing, generates a bending moment. As is well known, the two above-mentioned moments are the main elements for calculating the dimensions of the rudder shaft and of the hydraulic steering system.

Figure 2



The maximum lift that may be generated by a rudder, as a function of its angle of attack ?? is limited by a series of events that cause the rudder to stall. When a rudder stalls, lift suddenly falls to very low or null values, therefore, in the design phase this possibility must be carefully studied and avoided. Stall occurs when the flow separates from the rudder low-pressure area and envelops an area of vortical flow. As previously mentioned, this separation generates an abrupt decrease in lift. The point at which the flow changes from laminar to turbulent is mainly a function of the Reynolds number, that is, a function of chord, relative speed and angle of attack. Three are the events related to stall: separation of the laminar flow, cavitation and ventilation. The most detrimental of them, that is, the one that by itself may generate stall, is the separation of the laminar flow, followed by ventilation and, lastly, cavitation. Cavitation, even if in a minor way, may reduce rudder thrust. The effect of cavitation is not as harmful, for it

results in the reduction in inclination of the lift curve, compared to speed, rather than in a real decrease in thrust (see Figure 2).

Figure 3

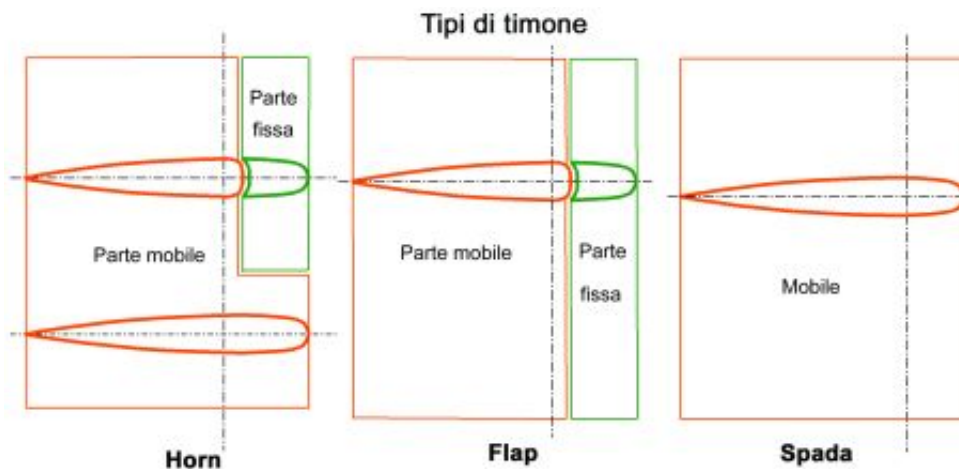

Ventilation, like cavitation, is a consequence of the low-pressure values occurring in the flow adjacent to the rudder's passive surface. Ventilation, in this case, is the air suction appearing between the atmosphere and the low-pressure area occurring on the rudder's passive surface. Generally, this phenomenon happens only when the rudder is too near the water surface and when the pressure difference, between the atmosphere and the rudder's passive surface (see Figure 1), overcomes the resistance to the air passing through the interposed water. In practice, as everybody knows, this problem is solved by fitting a plate (see Figure 7) between the rudder's top and the water level. In many cases this plate is represented by the hull itself.

Figure 4

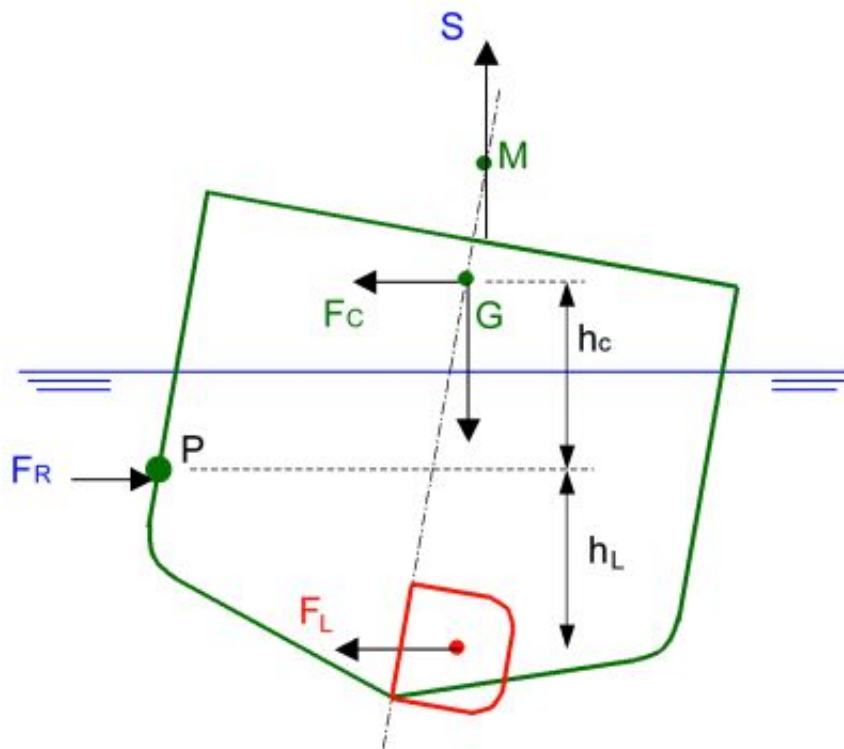

- S** = Spinta idrostatica
- M** = Metacentro
- G** = Centro di gravità
- P** = Punto di applicazione della resistenza trasversale
- F<sub>R</sub>** = Resistenza trasversale che la nave trova in virata
- F<sub>C</sub>** = Forza centrifuga
- F<sub>L</sub>** = Forza generata dal timone

Another important factor to be considered before starting the design of a rudder is to establish the number of rudders to be used and their location. The hull wake diminishes the speed of the laminar flow that hits the rudder, while the propeller produces the opposite effect. In single-screw ships and narrow stern the two effects mostly cancel each other, while in twin-screw ships with rudders behind the propellers the effect of the slipping wake is considerable. The propeller not only modifies the speed of the water outflow going to the rudder but it also substantially slows the stall, thus remarkably improving the rudder performance for angles of attack greater than the angle of stall.

Figure 5



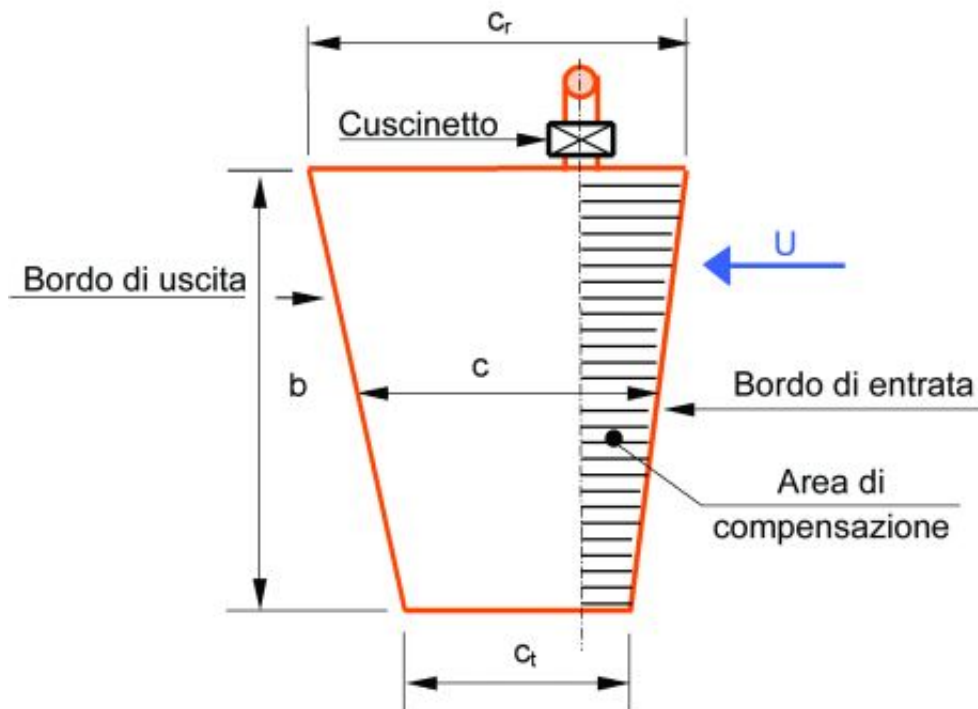

- $U$  = Direzione del moto  
 $c_r$  = Corda di radice  
 $c_t$  = Corda di estremità  
 $c$  = Corda media  
 $b$  = Altezza

Consequently, the rudder maximum efficacy occurs when it is hit by the propeller race. Single-screw ships always have one rudder; twin-screw ships may have one central rudder or two rudders behind the propellers; generally, three-screw ships have just one rudder behind the central propeller and often, four-screw ships are steered by two rudders that are hit by the stern-propellers race. In twin- or four-screw ships, fitting two side rudders behind the propellers is much more efficient than fitting just one central rudder, even when the total surface is the same. This is true because the feeding speed increases as a consequence of the low coefficient of hull wake and of the effect of the propeller race. Moreover, total area and rudder height being equal, generally affected by the ship immersion, the two side rudders have greater height and thus greater lift coefficient, tiller angle being equal (see Figure 6).

Figure 6

## Effetto del coefficiente di forma "a" sulla portanza

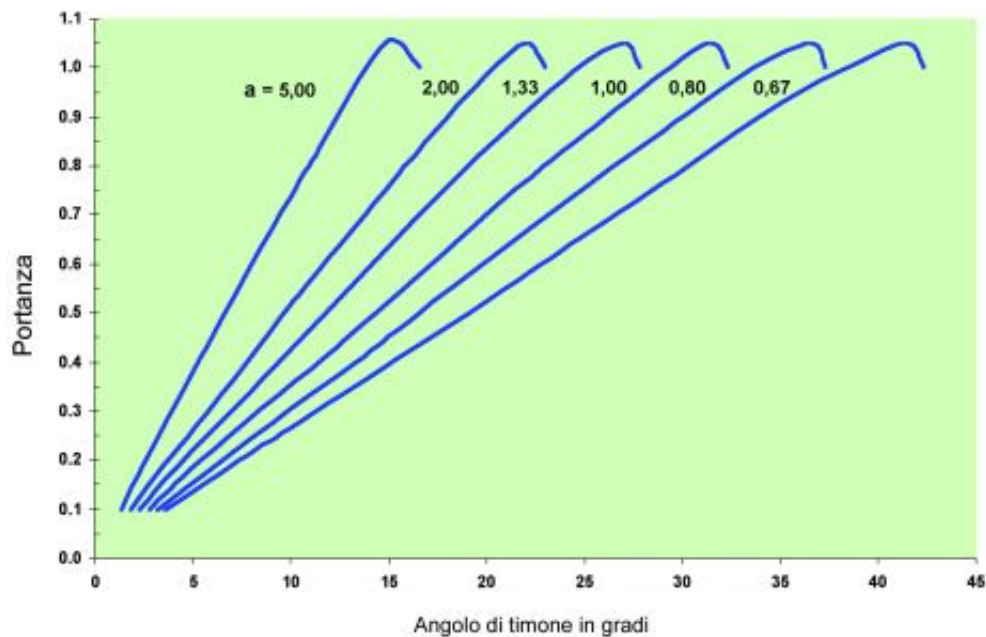

As everybody knows, lift increases with the increase of the angle of attack and with the square of the impact speed. When fitting the rudder astern of the propeller, one must verify that, even though it benefits from greater speed, it is not hit by the propeller hub vortex (see Figure 8), which not only has the effect of reducing the lift, but also of causing erosions and eventually annoying vibrations. For this reason, the rudder is often installed slightly towards the inside compared to the propeller center. If the above-mentioned conditions are satisfied, the rudder shall be fitted the most astern as possible, with the clear purpose of obtaining the maximum arm K compared with the center of gravity of the ship and, as a consequence, the best turning characteristics (see Figure 1). There are three main types of rudder: the Flap, the Horn and the Spade types (see Figure 3). The Flap and Horn rudders may be useful whenever, for reasons of directional stability, an additional surface is needed besides the existing one and when all of the above-mentioned surfaces should not be mobile. Moreover, they should be fitted when a fixed supporting structure is preferable in order not to load excessively the rudder shaft and its supports. If the turning qualities are to be improved, the rudder surface compared to the lateral ship surface is to be increased; yet, if both are increased, the hull

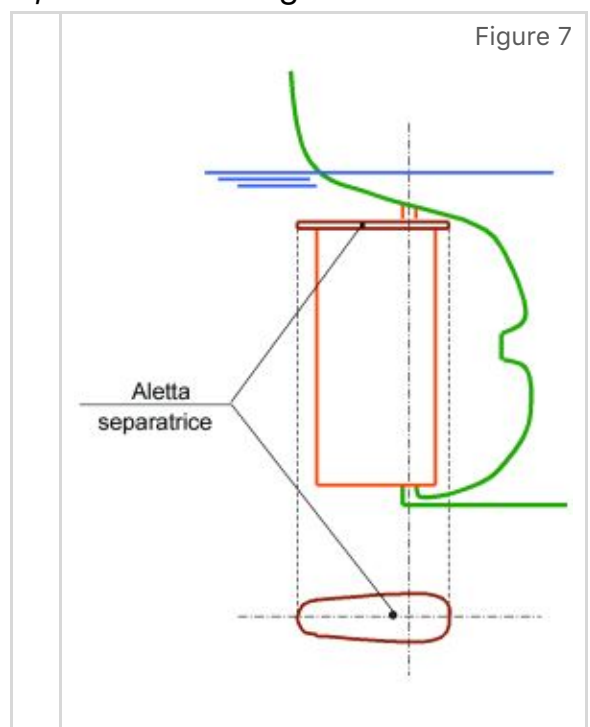

dynamic stability improves and, as a consequence, also its straight line path stability. Nevertheless, one must be careful in fitting the rudder and the lateral ship surface because they may affect in a negative way the ship's dynamic stability. In fact, as explained in the previous article on maneuverability, when the rudder is taken to tiller angle  $\theta$  and the ship starts turning, various forces are generated the moments of which  $(F \cdot h)$  make the ship list. If the rudder is pushed to the right (see Figure 4) and the moment given by  $FL \cdot hL$  (the force generated by the rudder multiplied by the vertical distance between the center of application P of the total transversal resistance that the ship encounters when turning) is greater than the moment  $FC \cdot hC$  (the centrifugal force of the ship applied to the center of gravity G multiplied by the vertical distance between G and P), the ship shall list to the right. Vice versa, if the rudder moment is smaller than the moment given by the centrifugal force, the ship shall list to the left. Therefore, the rudder surface, location and shape affect the listing moment during the turn and, as a consequence, also the listing angle. In following seas, even a prominent lateral ship surface generates a transversal listing force that, if not adequately countered by an efficient rudder, may cause dangerous transversal listings, especially if the ship has a low stability index. One of the rudder characteristic data is the figure ratio  $a$  defined as the ratio between rudder height  $b$  and its medium chord  $c$  (see Figure 5).

In a Spade rudder (see Figures 5 and 9) with a high figure ratio  $a = b/c$  there is:

- a greater vertical distance from the center of pressure and, as a consequence, a greater bending moment for calculating the rudder shaft,
- an increase in the lift coefficient (Figure 6),
- a low angle of attack  $\theta$  at which stall occurs (Figure 6),

Figure 8

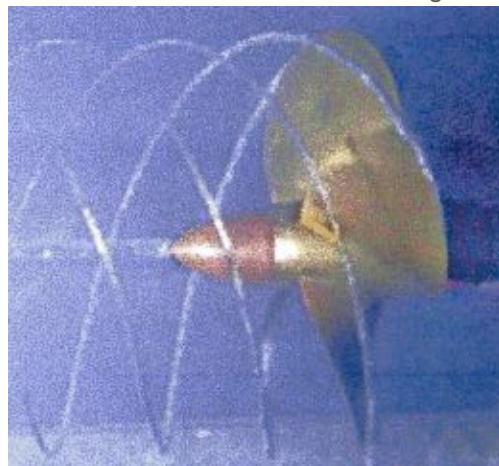

Figure 9



- a greater listing during the turn.

The area forward of the rudder shaft is called compensation area (Figure 5). This area and thus the compensation degree to be assigned to the rudder, i.e. the ratio between the rudder surface forward of the shaft and its total surface, must be such as to be able to obtain a low torque both in forward as well as in reverse gears.

NACA sections are to be considered among the various profile sections for rudder construction and NACA 0015 offers the best combination of hydrodynamic qualities and construction possibilities for Spade rudders. Usually, this type of rudder has a trapezoidal shape, which not only increases the center of pressure by reducing arm  $hT$ , but it also has an elliptical distribution of load along its height. This distribution opposes minimum resistance and improves the lift curve.

The bottom end of the rudder may be squared, that is with a sharp edge, or rounded. Testing showed that rudders with squared bottom have greater lift than rudders with rounded bottom. Nevertheless, design practical conditions such as resistance to progress, rudder weight, rudder support weight and steering gear weight impose the construction of a rudder with the smallest possible surface. Therefore, the designer is faced with a problem the solutions of which can only be a compromise and the technical approach of which is complicated by the influence of several factors which come into play in addition to the rudder's main ones.