

UNIVERSIDADE DA CORUÑA



Escola Politécnica Superior

Trabajo Fin de Máster

CURSO 2017/2018

*BUQUE PORTACONTENEDORES POST PANAMAX
9000 TEU's*

9000 TEU POST PANAMAX CONTAINERSHIP

*BUQUE PORTACONTENEDORES POST PANAMAX
9000 TEU's*

Máster en Ingeniería Naval y Oceánica

ALUMNA

Nadia Conde Alonso

TUTOR

José Daniel Pena Agras

FECHA

FEBRERO 2018



UNIVERSIDADE DA CORUÑA



Escola Politécnica Superior

**TRABAJO FIN DE MÁSTER
CURSO 2017/2018**

*BUQUE PORTACONTENEDORES POST PANAMAX
9000 TEU's*

Máster en Ingeniería Naval y Oceánica

Cuaderno 4

CÁLCULOS DE ARQUITECTURA NAVAL



DEPARTAMENTO DE INGENIERÍA NAVAL Y OCEÁNICA

TRABAJO FIN DE MÁSTER

CURSO 2017-2018

PROYECTO NÚMERO: 18-02

TIPO DE BUQUE: Buque Portacontenedores Post-panamax.

CLASIFICACIÓN, COTA Y REGLAMENTOS DE APLICACIÓN: Lloyd's Register. Marpol. Solas.

CARACTERÍSTICAS DE LA CARGA: 9000 TEUS.

VELOCIDAD Y AUTONOMÍA: Velocidad máxima de 25,5 nudos, al 85% de MCR y 10% de margen de mar.

SISTEMAS Y EQUIPOS DE CARGA / DESCARGA: Sin grúas.

PROPULSIÓN: Motor acoplado a la línea de ejes.

TRIPULACIÓN Y PASAJE: 15 camarotes oficiales, 13 camarotes tripulación.

OTROS EQUIPOS E INSTALACIONES: Los habituales en este tipo de buque.

Ferrol, Octubre de 2017

ALUMNO: D^a Nadia Conde Alonso.

ÍNDICE

1	Introducción	6
2	Tablas de Hidrostáticas.....	7
2.1	Hidrostáticas para un Trimado de 1 m	8
2.2	Hidrostáticas para un Trimado de 0,5 m	9
2.3	Hidrostáticas para un Trimado de 0 m	10
2.4	Hidrostáticas para un Trimado de -0,5 m	11
3	Curvas de KN'S	12
3.1	Curva de KN'S para un Trimado de 1 m	13
3.2	Curva de KN'S para un Trimado de 0,5 m	13
3.3	Curva de KN'S para un Trimado de 0 m	14
3.4	Curva de KN'S para un Trimado de -0,5 m	14
4	Zona Estanca del Buque.....	15
5	Puntos de Inundación Progresiva del Buque.....	16
6	Justificación del Compartimentado.....	17
6.1	Compartimentado Longitudinal	17
6.2	Compartimentado Vertical.....	19
6.3	Compartimentado Transversal.....	20
7	Justificación de las Capacidades de Tanques y Bodegas	21
7.1	Tanques de Combustible	21
7.1.1	Tanques Almacén de Combustible	21
7.1.2	Tanques de Uso Diario	22
7.1.3	Tanques de Sedimentación	22
7.2	Tanques de Diésel.....	23
7.2.1	Tanques Diésel de Uso Diario	23
7.2.2	Tanques Diésel de Sedimentación.....	23
7.3	Tanques de Agua Dulce.....	24
7.3.1	Tanques de Agua Potable	24
7.3.2	Agua Técnica.....	25
7.4	Tanques de Aceite	26
7.5	Otros Tanques	26
7.5.1	Tanques de Lodos.....	26

7.5.2 Tanques de Aguas Residuales	27
7.5.3 Tanques de Aceite Usado.....	28
7.6 Tanques de Lastre	29
7.7 Contenedores en Bodega	31
8 Tabla Resumen Capacidades	33
Anexo I: Curvas Hidrostáticas y KN Maxsurf.....	36
Anexo II: Resultados Calibración Tanques Maxsurf.....	46
Anexo III: Características Técnicas Motor	159
Anexo IV: Planos Disposición Contenedores	162
Anexo V: Plano Disposición Tanques	165

1 INTRODUCCIÓN

El objetivo de este cuaderno será la realización de cálculos de arquitectura naval como tablas de características hidrostáticas, tablas de brazos de adrizamiento (KN's) y la definición de la zona estanca del buque y sus puntos de inundación progresiva. También se tratará de determinar el compartimentado del buque con sus diferentes compartimentos y tanques así como planos del mismo y capacidades y centros de gravedad de estos.

A continuación se muestran las dimensiones obtenidas y utilizadas en los cuadernos anteriores:

TEU'S TOTALES	9000 TEU'S
TEU'S BODEGA	4256 TEU'S
TEU'S CUBIERTA	4744 TEU'S
ESLORA TOT (<i>LOA</i>)	333,37 m.
ESLORA PERPENDICULARES (<i>LPP</i>)	318,4 m.
MANGA (<i>B</i>)	44,23 m.
PUNTAL (<i>D</i>)	26,41 m.
CALADO (<i>T</i>)	14,73 m.
DESPLAZAMIENTO (Δ)	144.194 ton.
VELOCIDAD (<i>V</i>)	25,5 kn.

N FROUD	0,235
COEF BLOQUE	0,67
COEF MAESTRA	0,99
COEF PRISM	0,68

2 TABLAS DE HIDROSTÁTICAS

Para el cálculo de las hidrostáticas se utilizará el modelo obtenido mediante transformación paramétrica del Cuaderno 3. Se introducirá este en el programa *Maxsurf Stability*, utilizando para el cálculo la opción "Upright Hydrostatics".

El calado mínimo será el de peso en rosca y el superior el de máxima carga obtenido del francobordo (19,20 m). Para obtener el calado de peso en rosca se introduce el valor de este, obtenido en el Cuaderno 2 (47.571 ton), en el programa y nos da el calado correspondiente (5,719 m) como se muestra en la siguiente tabla:

Draft Amidships	5,719
Displacement t	47571
Heel deg	0
Draft at FP m	5,719
Draft at AP m	5,719
Draft at LCF m	5,719
Trim (+ve by stern) m	0
WL Length m	316,772
Beam max extents on WL m	44,22
Wetted Area m ²	11234,675
Waterpl. Area m ²	9264,686
Prismatic coeff. (Cp)	0,59
Block coeff. (Cb)	0,575
Max Sect. area coeff. (Cm)	0,98
Waterpl. area coeff. (Cwp)	0,656
LCB from zero pt. (+ve fwd) m	157,841
LCF from zero pt. (+ve fwd) m	156,327
KB m	3,037
KG m	14,73
BMt m	24,515
BML m	936,483
GMt m	12,822
GML m	924,79
KMt m	27,552
KML m	939,52
Immersion (TPc) tonne/cm	94,963
MTc tonne.m	1381,847
RM at 1deg = GMt.Disp.sin(1) tonne.m	10645,331
Max deck inclination deg	0
Trim angle (+ve by stern) deg	0

Se tomarán 13 calados desde 4,5 hasta 20,5 m, con intervalos de 1 m y para trimados de 1, 0,5, 0 y -0,5% de la eslora entre perpendiculares.

2.1 HIDROSTÁTICAS PARA UN TRIMADO DE 1 M

Draft amidships m	4,50	5,50	6,50	7,50	8,50	9,50	10,50	11,50	12,50	13,50	14,50	15,50	16,50	17,50	18,50	19,50	20,50
Displacement t	36537,00	45924,00	55665,00	65746,00	76137,00	86797,00	97732,00	108964,00	120488,00	132302,00	144369,00	156637,00	169089,00	181725,00	194546,00	207553,00	220746,00
Heel deg	0,00	0,00	0,00	0,00	0,00	0,00	0,00	0,00	0,00	0,00	0,00	0,00	0,00	0,00	0,00	0,00	0,00
Draft at FP m	2,91	3,91	4,91	5,91	6,91	7,91	8,91	9,91	10,91	11,91	12,91	13,91	14,91	15,91	16,91	17,91	18,91
Draft at AP m	6,09	7,09	8,09	9,09	10,09	11,09	12,09	13,09	14,09	15,09	16,09	17,09	18,09	19,09	20,09	21,09	22,09
Draft at LCF m	4,56	5,57	6,58	7,60	8,62	9,63	10,66	11,69	12,72	13,74	14,75	15,76	16,75	17,73	18,72	19,70	20,68
Trim (+ve by stern) m	3,18	3,18	3,18	3,18	3,18	3,18	3,18	3,18	3,18	3,18	3,18	3,18	3,18	3,18	3,18	3,18	3,18
WL Length m	314,17	315,53	316,34	316,85	317,00	317,05	319,23	323,61	327,98	329,39	327,05	325,54	325,30	325,60	326,09	326,64	327,25
Beam max extents on WL m	44,21	44,22	44,23	44,23	44,23	44,23	44,23	44,23	44,23	44,23	44,23	44,23	44,23	44,23	44,23	44,23	44,23
Wetted Area m ²	10346,55	11144,42	11950,27	12762,22	13545,63	14330,44	15137,46	15978,04	16832,41	17700,97	18497,65	19254,65	19993,12	20734,03	21483,56	22240,44	23007,42
Waterpl. Area m ²	8981,63	9333,57	9670,82	9995,11	10269,74	10526,05	10812,68	11098,93	11379,35	11661,81	11873,95	12059,19	12238,51	12418,48	12598,24	12777,59	12960,19
Prismatic coeff. (Cp)	0,58	0,59	0,61	0,62	0,63	0,64	0,65	0,67	0,68	0,69	0,70	0,71	0,72	0,73	0,74	0,74	0,75
Block coeff. (Cb)	0,56	0,58	0,59	0,61	0,62	0,63	0,64	0,66	0,67	0,68	0,69	0,70	0,71	0,72	0,73	0,74	0,74
Max Sect. area coeff. (Cm)	0,98	0,98	0,98	0,98	0,99	0,99	0,99	0,99	0,99	0,99	0,99	0,99	0,99	0,99	0,99	0,99	0,99
Waterpl. area coeff. (Cwp)	0,64	0,66	0,69	0,71	0,73	0,75	0,77	0,79	0,81	0,83	0,84	0,85	0,87	0,88	0,89	0,91	0,92
LCB from zero pt. (+ve fwd) m	146,97	148,23	148,87	149,08	149,00	148,72	148,25	147,59	146,78	145,84	144,87	143,99	143,26	142,70	142,30	142,06	141,95
LCF from zero pt. (+ve fwd) m	153,57	152,60	151,14	149,33	147,65	145,78	143,23	140,47	137,67	135,02	133,74	133,69	134,51	135,87	137,53	139,30	141,17
KB m	2,46	2,99	3,53	4,08	4,63	5,18	5,74	6,30	6,86	7,43	8,00	8,57	9,13	9,70	10,26	10,82	11,38
KG m	14,73	14,73	14,73	14,73	14,73	14,73	14,73	14,73	14,73	14,73	14,73	14,73	14,73	14,73	14,73	14,73	14,73
BMt m	30,89	25,91	22,48	20,01	18,02	16,42	15,16	14,14	13,27	12,54	11,90	11,31	10,75	10,22	9,74	9,31	8,93
BML m	1111,79	975,07	879,91	809,38	747,88	697,02	661,53	631,88	605,82	584,10	556,61	531,84	511,45	494,54	479,86	466,71	455,25
GMt m	18,50	14,06	11,18	9,26	7,82	6,77	6,06	5,59	5,28	5,10	5,03	5,00	4,99	5,03	5,11	5,23	5,41
GML m	1099,40	963,22	868,61	798,62	737,68	687,37	652,43	623,33	597,83	576,67	549,74	525,53	505,70	489,34	475,22	462,63	451,73
KMt m	33,35	28,90	26,01	24,09	22,65	21,60	20,90	20,43	20,13	19,97	19,90	19,88	19,88	19,92	20,00	20,13	20,31
KML m	1114,19	978,01	883,40	813,41	752,47	702,17	667,24	638,14	612,65	591,50	564,58	540,38	520,56	504,21	490,10	477,51	466,61
Immersion (TPc) tonne/cm	92,06	95,67	99,13	102,45	105,27	107,89	110,83	113,76	116,64	119,53	121,71	123,61	125,45	127,29	129,13	130,97	132,84
MTc tonne.m	1261,71	1389,44	1518,73	1649,26	1764,16	1873,99	2002,84	2133,42	2262,52	2396,44	2492,90	2585,61	2685,83	2793,18	2903,98	3016,06	3132,20
RM at 1deg = GMt.Disp.sin(1) tonne.m	11795,89	11267,15	10860,83	10624,53	10387,56	10248,71	10330,30	10623,98	11095,66	11783,50	12672,53	13663,58	14736,37	15944,26	17334,13	18955,58	20843,60
Max deck inclination deg	0,57	0,57	0,57	0,57	0,57	0,57	0,57	0,57	0,57	0,57	0,57	0,57	0,57	0,57	0,57	0,57	0,57
Trim angle (+ve by stern) deg	0,57	0,57	0,57	0,57	0,57	0,57	0,57	0,57	0,57	0,57	0,57	0,57	0,57	0,57	0,57	0,57	0,57

2.2 HIDROSTÁTICAS PARA UN TRIMADO DE 0,5 M

Draft amidships m	4,50	5,50	6,50	7,50	8,50	9,50	10,50	11,50	12,50	13,50	14,50	15,50	16,50	17,50	18,50	19,50	20,50
Displacement t	36330,00	45662,00	55320,00	65297,00	75578,00	86124,00	96913,00	107966,00	119302,00	130928,00	142871,00	155102,00	167578,00	180277,00	193183,00	206289,00	219585,00
Heel deg	0,00	0,00	0,00	0,00	0,00	0,00	0,00	0,00	0,00	0,00	0,00	0,00	0,00	0,00	0,00	0,00	0,00
Draft at FP m	3,70	4,70	5,70	6,70	7,70	8,70	9,70	10,70	11,70	12,70	13,70	14,70	15,70	16,70	17,70	18,70	19,70
Draft at AP m	5,30	6,30	7,30	8,30	9,30	10,30	11,30	12,30	13,30	14,30	15,30	16,30	17,30	18,30	19,30	20,30	21,30
Draft at LCF m	4,52	5,52	6,53	7,54	8,55	9,56	10,57	11,58	12,60	13,61	14,62	15,62	16,62	17,61	18,60	19,59	20,58
Trim (+ve by stern) m	1,59	1,59	1,59	1,59	1,59	1,59	1,59	1,59	1,59	1,59	1,59	1,59	1,59	1,59	1,59	1,59	1,59
WL Length m	315,24	316,20	316,81	316,97	316,98	316,76	316,88	318,68	322,41	325,38	325,68	325,29	325,50	325,97	326,51	327,11	327,77
Beam max extents on WL m	44,20	44,22	44,23	44,23	44,23	44,23	44,23	44,23	44,23	44,23	44,23	44,23	44,23	44,23	44,23	44,23	44,23
Wetted Area m ²	10323,18	11101,58	11891,15	12690,01	13483,73	14258,73	15044,81	15863,72	16708,67	17566,97	18422,88	19210,46	19973,96	20729,34	21485,24	22249,12	23014,48
Waterpl. Area m ²	8940,85	9265,49	9580,18	9884,28	10164,43	10404,14	10642,80	10918,55	11193,73	11491,11	11800,76	12057,20	12283,12	12491,08	12686,84	12877,56	13066,82
Prismatic coeff. (Cp)	0,58	0,59	0,60	0,62	0,63	0,64	0,65	0,66	0,67	0,68	0,69	0,70	0,71	0,72	0,73	0,74	0,75
Block coeff. (Cb)	0,56	0,57	0,59	0,60	0,62	0,63	0,64	0,65	0,66	0,67	0,68	0,69	0,70	0,71	0,72	0,73	0,74
Max Sect. area coeff. (Cm)	0,98	0,98	0,98	0,98	0,99	0,99	0,99	0,99	0,99	0,99	0,99	0,99	0,99	0,99	0,99	0,99	0,99
Waterpl. area coeff. (Cwp)	0,63	0,66	0,68	0,70	0,72	0,74	0,75	0,77	0,79	0,81	0,84	0,85	0,87	0,89	0,90	0,91	0,93
LCB from zero pt. (+ve fwd) m	152,51	153,07	153,23	153,10	152,72	152,20	151,55	150,76	149,84	148,83	147,77	146,77	145,93	145,26	144,77	144,45	144,27
LCF from zero pt. (+ve fwd) m	155,74	154,71	153,22	151,37	149,37	147,46	145,27	142,48	139,74	137,20	135,37	135,11	135,84	137,14	138,74	140,52	142,40
KB m	2,41	2,94	3,48	4,02	4,57	5,12	5,67	6,22	6,78	7,34	7,91	8,48	9,05	9,62	10,18	10,75	11,31
KG m	14,73	14,73	14,73	14,73	14,73	14,73	14,73	14,73	14,73	14,73	14,73	14,73	14,73	14,73	14,73	14,73	14,73
BMt m	30,67	25,65	22,22	19,74	17,85	16,28	15,01	14,01	13,18	12,46	11,87	11,33	10,83	10,33	9,87	9,45	9,07
BML m	1116,51	970,23	869,51	794,94	734,47	680,53	636,98	606,71	581,16	563,81	552,34	537,53	522,24	507,39	493,11	480,05	468,16
GMt m	18,31	13,83	10,94	9,01	7,66	6,64	5,91	5,46	5,18	5,03	4,99	5,02	5,08	5,15	5,25	5,39	5,58
GML m	1104,15	958,41	858,23	784,20	724,28	670,89	627,88	598,16	573,17	556,37	545,47	531,22	516,49	502,20	488,49	476,00	464,67
KMt m	33,08	28,59	25,70	23,77	22,42	21,40	20,68	20,24	19,96	19,81	19,78	19,81	19,87	19,95	20,05	20,20	20,38
KML m	1118,90	973,16	872,98	798,95	739,03	685,65	642,64	612,92	587,94	571,15	560,25	546,00	531,28	517,00	503,29	490,80	479,47
Immersion (TPc) tonne/cm	91,64	94,97	98,20	101,31	104,19	106,64	109,09	111,92	114,74	117,78	120,96	123,59	125,90	128,03	130,04	132,00	133,94
MTC tonne.m	1259,99	1374,60	1491,30	1608,39	1719,39	1814,88	1911,31	2028,50	2147,83	2288,09	2447,87	2587,99	2718,66	2843,76	2964,17	3084,30	3204,94
RM at 1deg = GMt.Disp.sin(1) tonne.m	11611,24	11020,06	10558,44	10263,76	10105,68	9972,95	10003,33	10296,42	10787,83	11483,23	12442,05	13589,24	14843,54	16201,69	17707,48	19410,68	21369,52
Max deck inclination deg	0,29	0,29	0,29	0,29	0,29	0,29	0,29	0,29	0,29	0,29	0,29	0,29	0,29	0,29	0,29	0,29	0,29
Trim angle (+ve by stern) deg	0,29	0,29	0,29	0,29	0,29	0,29	0,29	0,29	0,29	0,29	0,29	0,29	0,29	0,29	0,29	0,29	0,29

2.3 HIDROSTÁTICAS PARA UN TRIMADO DE 0 M

Draft amidships m	4,50	5,50	6,50	7,50	8,50	9,50	10,50	11,50	12,50	13,50	14,50	15,50	16,50	17,50	18,50	19,50	20,50
Displacement t	36218,00	45496,00	55077,00	64951,00	75112,00	85541,00	96201,00	107090,00	118249,00	129711,00	141509,00	153674,00	166157,00	178908,00	191895,00	205094,00	218497,00
Heel deg	0,00	0,00	0,00	0,00	0,00	0,00	0,00	0,00	0,00	0,00	0,00	0,00	0,00	0,00	0,00	0,00	0,00
Draft at FP m	4,50	5,50	6,50	7,50	8,50	9,50	10,50	11,50	12,50	13,50	14,50	15,50	16,50	17,50	18,50	19,50	20,50
Draft at AP m	4,50	5,50	6,50	7,50	8,50	9,50	10,50	11,50	12,50	13,50	14,50	15,50	16,50	17,50	18,50	19,50	20,50
Draft at LCF m	4,50	5,50	6,50	7,50	8,50	9,50	10,50	11,50	12,50	13,50	14,50	15,50	16,50	17,50	18,50	19,50	20,50
Trim (+ve by stern) m	0,00	0,00	0,00	0,00	0,00	0,00	0,00	0,00	0,00	0,00	0,00	0,00	0,00	0,00	0,00	0,00	0,00
WL Length m	315,96	316,64	316,93	317,02	316,80	316,30	315,49	315,40	316,56	319,68	324,11	325,43	325,86	326,40	326,99	327,64	328,34
Beam max extents on WL m	44,20	44,22	44,22	44,23	44,23	44,23	44,23	44,23	44,23	44,23	44,23	44,23	44,23	44,23	44,23	44,23	44,23
Wetted Area m ²	10304,64	11066,84	11839,66	12623,82	13419,53	14198,56	14975,80	15765,81	16596,32	17437,47	18302,93	19150,50	19948,84	20724,00	21492,28	22258,03	23024,29
Waterpl. Area m ²	8900,07	9200,83	9491,07	9773,38	10048,18	10287,67	10505,63	10741,28	11027,11	11334,72	11690,78	12033,39	12315,66	12556,47	12773,92	12978,43	13174,73
Prismatic coeff. (Cp)	0,57	0,59	0,60	0,61	0,62	0,63	0,64	0,65	0,66	0,67	0,68	0,69	0,70	0,72	0,73	0,74	0,74
Block coeff. (Cb)	0,56	0,57	0,59	0,60	0,61	0,62	0,63	0,64	0,65	0,66	0,68	0,69	0,70	0,71	0,72	0,73	0,74
Max Sect. area coeff. (Cm)	0,98	0,98	0,98	0,98	0,99	0,99	0,99	0,99	0,99	0,99	0,99	0,99	0,99	0,99	0,99	0,99	0,99
Waterpl. area coeff. (Cwp)	0,63	0,65	0,67	0,69	0,71	0,73	0,74	0,76	0,78	0,80	0,83	0,85	0,87	0,89	0,91	0,92	0,93
LCB from zero pt (+ve fwd) m	158,08	157,90	157,56	157,05	156,38	155,60	154,74	153,81	152,79	151,72	150,63	149,58	148,66	147,90	147,32	146,91	146,65
LCF from zero pt. (+ve fwd) m	157,70	156,62	155,11	153,22	151,02	148,89	146,78	144,38	141,76	139,63	137,89	137,10	137,49	138,58	140,08	141,82	143,66
KB m	2,39	2,92	3,46	4,00	4,54	5,08	5,63	6,17	6,72	7,28	7,84	8,41	8,98	9,55	10,12	10,69	11,26
KG m	14,73	14,73	14,73	14,73	14,73	14,73	14,73	14,73	14,73	14,73	14,73	14,73	14,73	14,73	14,73	14,73	14,73
BMt m	30,40	25,38	21,95	19,48	17,64	16,14	14,89	13,88	13,08	12,40	11,82	11,32	10,87	10,42	9,99	9,58	9,20
BML m	1116,22	962,98	856,91	778,47	717,45	663,70	616,98	581,13	559,34	545,86	543,33	540,78	531,79	519,47	506,31	493,48	481,13
GMt m	18,06	13,57	10,67	8,74	7,45	6,49	5,79	5,33	5,08	4,95	4,92	5,00	5,11	5,24	5,38	5,54	5,74
GML m	1103,87	951,17	845,63	767,74	707,26	654,05	607,88	572,57	551,33	538,41	536,44	534,45	526,04	514,29	501,70	489,44	477,66
KMt m	32,79	28,30	25,40	23,47	22,18	21,22	20,52	20,06	19,81	19,68	19,65	19,73	19,84	19,97	20,11	20,27	20,47
KML m	1118,60	965,90	860,36	782,47	721,99	668,78	622,61	587,30	566,06	553,14	551,17	549,18	540,77	529,02	516,43	504,17	492,39
Immersion (TPc) tonne/cm	91,23	94,31	97,28	100,18	102,99	105,45	107,68	110,10	113,03	116,18	119,83	123,34	126,24	128,70	130,93	133,03	135,04
MTc tonne.m	1255,79	1359,27	1462,93	1566,30	1668,65	1757,36	1836,84	1925,99	2047,80	2193,62	2384,41	2579,79	2745,43	2890,11	3024,03	3153,03	3278,25
RM at 1deg = GMt.Disp.sin(1) tonne.m	11414,84	10772,81	10257,35	9908,52	9760,43	9691,93	9715,36	9955,97	10475,57	11197,75	12159,22	13397,51	14827,27	16361,96	18012,47	19829,88	21873,31
Max deck inclination deg	0,00	0,00	0,00	0,00	0,00	0,00	0,00	0,00	0,00	0,00	0,00	0,00	0,00	0,00	0,00	0,00	0,00
Trim angle (+ve by stern) deg	0,00	0,00	0,00	0,00	0,00	0,00	0,00	0,00	0,00	0,00	0,00	0,00	0,00	0,00	0,00	0,00	0,00

2.4 HIDROSTÁTICAS PARA UN TRIMADO DE -0,5 M

Draft amidships m	4,50	5,50	6,50	7,50	8,50	9,50	10,50	11,50	12,50	13,50	14,50	15,50	16,50	17,50	18,50	19,50	20,50
Displacement t	36192,00	45417,00	54921,00	64696,00	74737,00	85037,00	95570,00	106324,00	117328,00	128652,00	140329,00	152395,00	164851,00	177635,00	190689,00	203979,00	217490,00
Heel deg	0,00	0,00	0,00	0,00	0,00	0,00	0,00	0,00	0,00	0,00	0,00	0,00	0,00	0,00	0,00	0,00	0,00
Draft at FP m	5,30	6,30	7,30	8,30	9,30	10,30	11,30	12,30	13,30	14,30	15,30	16,30	17,30	18,30	19,30	20,30	21,30
Draft at AP m	3,70	4,70	5,70	6,70	7,70	8,70	9,70	10,70	11,70	12,70	13,70	14,70	15,70	16,70	17,70	18,70	19,70
Draft at LCF m	4,50	5,50	6,49	7,48	8,47	9,46	10,44	11,43	12,42	13,42	14,41	15,40	16,40	17,41	18,41	19,42	20,43
Trim (+ve by stern) m	-1,59	-1,59	-1,59	-1,59	-1,59	-1,59	-1,59	-1,59	-1,59	-1,59	-1,59	-1,59	-1,59	-1,59	-1,59	-1,59	-1,59
WL Length m	316,29	316,81	317,01	316,84	316,42	315,71	314,48	312,44	312,11	315,07	320,10	325,47	326,29	326,87	327,51	328,21	328,96
Beam max extents on WL m	44,20	44,22	44,22	44,23	44,23	44,23	44,23	44,23	44,23	44,23	44,23	44,23	44,23	44,23	44,23	44,23	44,23
Wetted Area m ²	10290,00	11039,52	11796,78	12568,24	13352,94	14142,80	14918,99	15700,73	16504,13	17326,58	18176,37	19050,57	19908,14	20714,26	21497,24	22268,00	23038,60
Waterpl. Area m ²	8859,05	9138,28	9405,04	9666,81	9922,10	10166,44	10380,47	10601,98	10881,06	11211,50	11575,43	11963,69	12321,04	12608,14	12854,65	13076,90	13282,92
Prismatic coeff. (Cp)	0,57	0,59	0,60	0,61	0,62	0,63	0,64	0,65	0,66	0,67	0,68	0,69	0,70	0,71	0,72	0,73	0,74
Block coeff. (Cb)	0,56	0,57	0,58	0,60	0,61	0,62	0,63	0,64	0,65	0,66	0,67	0,68	0,69	0,70	0,71	0,72	0,73
Max Sect. area coeff. (Cm)	0,98	0,98	0,98	0,98	0,99	0,99	0,99	0,99	0,99	0,99	0,99	0,99	0,99	0,99	0,99	0,99	0,99
Waterpl. area coeff. (Cwp)	0,63	0,65	0,67	0,69	0,70	0,72	0,74	0,75	0,77	0,79	0,82	0,85	0,87	0,89	0,91	0,93	0,94
LCB from zero pt. (+ve fwd) m	163,66	162,70	161,82	160,92	159,96	158,92	157,84	156,74	155,63	154,51	153,43	152,39	151,42	150,60	149,93	149,44	149,11
LCF from zero pt. (+ve fwd) m	159,48	158,33	156,77	154,84	152,59	150,21	148,03	145,97	143,87	142,14	140,86	139,87	139,57	140,29	141,59	143,21	144,98
KB m	2,40	2,93	3,46	3,99	4,53	5,06	5,60	6,14	6,69	7,23	7,79	8,35	8,92	9,50	10,07	10,65	11,23
KG m	14,73	14,73	14,73	14,73	14,73	14,73	14,73	14,73	14,73	14,73	14,73	14,73	14,73	14,73	14,73	14,73	14,73
BMt m	30,09	25,09	21,68	19,22	17,39	15,98	14,78	13,78	12,99	12,34	11,77	11,29	10,87	10,48	10,09	9,71	9,34
BML m	1111,72	953,06	842,58	760,96	697,23	644,95	598,10	561,54	541,04	533,19	533,07	537,42	537,81	529,99	518,88	506,59	494,05
GMt m	17,74	13,27	10,39	8,48	7,18	6,31	5,65	5,20	4,96	4,86	4,86	4,95	5,10	5,29	5,48	5,67	5,89
GML m	1099,36	941,24	831,30	750,21	687,02	635,29	588,98	552,96	533,01	525,72	526,16	531,08	532,04	524,80	514,27	502,56	490,60
KMt m	32,49	28,02	25,13	23,21	21,92	21,04	20,38	19,92	19,67	19,57	19,56	19,64	19,80	19,98	20,16	20,35	20,57
KML m	1114,10	955,98	846,03	764,94	701,75	650,01	603,69	567,67	547,72	540,42	540,85	545,77	546,72	539,48	528,94	517,23	505,27
Immersion (TPc) tonne/cm	90,81	93,67	96,40	99,09	101,70	104,21	106,40	108,67	111,53	114,92	118,65	122,63	126,29	129,23	131,76	134,04	136,15
MTc tonne.m	1249,76	1342,75	1434,08	1524,54	1612,80	1696,88	1768,06	1846,72	1964,33	2124,44	2319,18	2542,15	2754,92	2928,19	3080,27	3219,92	3351,52
RM at 1deg = GMt.Disp.sin(1) tonne.m	11202,54	10521,17	9958,41	9569,52	9367,70	9365,77	9430,31	9656,27	10150,95	10916,56	11901,95	13158,54	14685,24	16401,73	18229,13	20196,03	22348,52
Max deck inclination deg	0,29	0,29	0,29	0,29	0,29	0,29	0,29	0,29	0,29	0,29	0,29	0,29	0,29	0,29	0,29	0,29	0,29
Trim angle (+ve by stern) deg	-0,29	-0,29	-0,29	-0,29	-0,29	-0,29	-0,29	-0,29	-0,29	-0,29	-0,29	-0,29	-0,29	-0,29	-0,29	-0,29	-0,29

3 CURVAS DE KN'S

Para el cálculo de las hidrostáticas se utilizará el mismo modelo que el utilizado en el apartado anterior y también el programa *Maxsurf Stability*, utilizando para el cálculo la opción "KN values".

Se utilizarán 17 desplazamientos, correspondientes a los 17 calados utilizados para el cálculo de las hidrostáticas. Los trimados serán los mismos que los utilizados en el apartado anterior: 1, 0,5, 0 y -0,5% de la eslora entre perpendiculares.

En este caso también se introducirán distintos ángulos de escora, que van desde los 0 a los 50 grados en intervalos de 5 grados.

Se adjuntan como Anexo I los resultados obtenidos del programa *Maxsurf* tanto de las curvas KN's como de las hidrostáticas calculadas en el apartado anterior.

Se muestran a continuación las diferentes tablas obtenidas para cada trimado:

3.1 CURVA DE KN'S PARA UN TRIMADO DE 1 M

Displacement t	Draft amidships m	Trim (+ve by stern) m	KN 0 deg	KN 5 deg	KN 10 deg	KN 15 deg	KN 20 deg	KN 25 deg	KN 30 deg	KN 35 deg	KN 40 deg	KN 45 deg	KN 50 deg
36537	4,50	3,184	0,00	2,91	5,78	8,36	10,31	11,84	13,12	14,19	15,10	15,85	16,45
45924	5,50	3,184	0,00	2,53	5,06	7,51	9,58	11,23	12,62	13,83	14,89	15,81	16,61
55665	6,50	3,184	0,00	2,28	4,57	6,85	8,97	10,73	12,23	13,54	14,71	15,76	16,71
65746	7,50	3,184	0,00	2,10	4,22	6,35	8,45	10,31	11,90	13,30	14,56	15,72	16,73
76137	8,50	3,184	0,00	1,98	3,97	5,99	8,03	9,95	11,63	13,11	14,45	15,67	16,68
86797	9,50	3,184	0,00	1,89	3,79	5,73	7,70	9,64	11,40	12,96	14,37	15,59	16,59
97732	10,50	3,184	0,00	1,83	3,67	5,54	7,45	9,38	11,20	12,83	14,29	15,50	16,48
108964	11,50	3,184	0,00	1,79	3,58	5,41	7,27	9,16	11,02	12,72	14,19	15,39	16,35
120488	12,50	3,184	0,00	1,76	3,53	5,32	7,14	9,00	10,86	12,61	14,07	15,27	16,18
132302	13,50	3,184	0,00	1,74	3,50	5,26	7,05	8,88	10,74	12,48	13,94	15,11	15,98
144369	14,50	3,184	0,00	1,74	3,48	5,23	6,99	8,80	10,63	12,33	13,78	14,91	15,77
156637	15,50	3,184	0,00	1,73	3,47	5,21	6,97	8,76	10,53	12,18	13,59	14,69	15,54
169089	16,50	3,184	0,00	1,74	3,47	5,21	6,97	8,73	10,43	12,01	13,37	14,45	15,29
181725	17,50	3,184	0,00	1,74	3,48	5,22	6,98	8,71	10,34	11,83	13,12	14,19	15,02
194546	18,50	3,184	0,00	1,75	3,50	5,25	7,00	8,68	10,24	11,63	12,86	13,90	14,75
207553	19,50	3,184	0,00	1,76	3,52	5,29	7,01	8,63	10,11	11,43	12,59	13,61	14,46
220746	20,50	3,184	0,00	1,77	3,55	5,32	7,00	8,56	9,96	11,21	12,32	13,30	14,16

3.2 CURVA DE KN'S PARA UN TRIMADO DE 0,5 M

Displacement t	Draft amidships m	Trim (+ve by stern) m	KN 0 deg	KN 5 deg	KN 10 deg	KN 15 deg	KN 20 deg	KN 25 deg	KN 30 deg	KN 35 deg	KN 40 deg	KN 45 deg	KN 50 deg
36330	4,50	1,592	0	2,89	5,73	8,28	10,21	11,73	13,00	14,08	14,98	15,72	16,31
45662	5,50	1,592	0	2,50	5,01	7,44	9,48	11,11	12,49	13,69	14,75	15,69	16,49
55320	6,50	1,592	0	2,25	4,52	6,77	8,87	10,61	12,09	13,39	14,57	15,64	16,61
65297	7,50	1,592	0	2,08	4,17	6,28	8,36	10,20	11,77	13,16	14,42	15,60	16,67
75578	8,50	1,592	0	1,96	3,93	5,92	7,94	9,84	11,51	12,99	14,32	15,58	16,62
86124	9,50	1,592	0	1,87	3,75	5,67	7,62	9,54	11,29	12,84	14,26	15,54	16,53
96913	10,50	1,592	0	1,81	3,63	5,48	7,38	9,29	11,11	12,73	14,22	15,44	16,44
107966	11,50	1,592	0	1,77	3,55	5,36	7,21	9,09	10,94	12,65	14,15	15,35	16,33
119302	12,50	1,592	0	1,74	3,50	5,28	7,09	8,94	10,81	12,58	14,04	15,25	16,17
130928	13,50	1,592	0	1,73	3,47	5,23	7,01	8,84	10,70	12,47	13,92	15,11	15,99
142871	14,50	1,592	0	1,73	3,46	5,21	6,97	8,77	10,63	12,33	13,79	14,93	15,79
155102	15,50	1,592	0	1,73	3,46	5,20	6,95	8,75	10,55	12,19	13,62	14,73	15,56
167578	16,50	1,592	0	1,73	3,47	5,21	6,96	8,75	10,45	12,05	13,41	14,49	15,32
180277	17,50	1,592	0	1,74	3,48	5,23	6,99	8,74	10,37	11,88	13,17	14,23	15,06
193183	18,50	1,592	0	1,75	3,50	5,26	7,03	8,71	10,28	11,69	12,92	13,95	14,79
206289	19,50	1,592	0	1,76	3,53	5,30	7,05	8,67	10,16	11,48	12,65	13,66	14,50
219585	20,50	1,592	0	1,78	3,56	5,35	7,04	8,61	10,02	11,26	12,37	13,35	14,20

3.3 CURVA DE KN'S PARA UN TRIMADO DE 0 M

Displacement t	Draft amidships m	Trim (+ve by stern) m	KN 0 deg	KN 5 deg	KN 10 deg	KN 15 deg	KN 20 deg	KN 25 deg	KN 30 deg	KN 35 deg	KN 40 deg	KN 45 deg	KN 50 deg
36218	4,50	0	0,00	2,86	5,68	8,20	10,10	11,61	12,86	13,94	14,85	15,59	16,18
45496	5,50	0	0,00	2,47	4,95	7,36	9,37	10,99	12,35	13,54	14,60	15,55	16,36
55077	6,50	0	0,00	2,22	4,46	6,70	8,77	10,49	11,96	13,25	14,42	15,50	16,49
64951	7,50	0	0,00	2,05	4,13	6,22	8,27	10,09	11,64	13,03	14,29	15,47	16,59
75112	8,50	0	0,00	1,94	3,89	5,86	7,86	9,74	11,40	12,86	14,20	15,48	16,56
85541	9,50	0	0,00	1,85	3,72	5,61	7,54	9,45	11,19	12,74	14,16	15,47	16,47
96201	10,50	0	0,00	1,79	3,60	5,43	7,31	9,21	11,02	12,64	14,15	15,39	16,40
107090	11,50	0	0,00	1,75	3,52	5,31	7,15	9,03	10,87	12,58	14,11	15,30	16,29
118249	12,50	0	0,00	1,73	3,47	5,24	7,04	8,89	10,75	12,54	14,01	15,22	16,16
129711	13,50	0	0,00	1,72	3,45	5,20	6,98	8,80	10,67	12,46	13,90	15,10	15,99
141509	14,50	0	0,00	1,72	3,44	5,19	6,95	8,75	10,62	12,33	13,79	14,94	15,80
153674	15,50	0	0,00	1,72	3,45	5,19	6,94	8,74	10,56	12,20	13,64	14,75	15,58
166157	16,50	0	0,00	1,73	3,46	5,20	6,96	8,76	10,47	12,07	13,44	14,52	15,35
178908	17,50	0	0,00	1,74	3,48	5,23	7,00	8,77	10,39	11,91	13,22	14,27	15,09
191895	18,50	0	0,00	1,76	3,51	5,27	7,05	8,73	10,31	11,73	12,96	14,00	14,82
205094	19,50	0	0,00	1,77	3,54	5,32	7,08	8,70	10,21	11,53	12,69	13,70	14,53
218497	20,50	0	0,00	1,79	3,58	5,38	7,07	8,65	10,06	11,31	12,41	13,39	14,23

3.4 CURVA DE KN'S PARA UN TRIMADO DE -0,5 M

Displacement t	Draft amidships m	Trim (+ve by stern) m	KN 0 deg	KN 5 deg	KN 10 deg	KN 15 deg	KN 20 deg	KN 25 deg	KN 30 deg	KN 35 deg	KN 40 deg	KN 45 deg	KN 50 deg
36192	4,50	-1,592	0,00	2,83	5,62	8,10	9,98	11,48	12,72	13,78	14,68	15,44	16,04
45417	5,50	-1,592	0,00	2,45	4,90	7,27	9,27	10,86	12,21	13,39	14,45	15,39	16,22
54921	6,50	-1,592	0,00	2,20	4,42	6,63	8,68	10,38	11,83	13,11	14,27	15,35	16,37
64696	7,50	-1,592	0,00	2,03	4,08	6,16	8,18	9,98	11,53	12,90	14,16	15,35	16,49
74737	8,50	-1,592	0,00	1,92	3,85	5,81	7,78	9,65	11,29	12,75	14,09	15,38	16,48
85037	9,50	-1,592	0,00	1,84	3,68	5,56	7,47	9,37	11,09	12,64	14,07	15,40	16,41
95570	10,50	-1,592	0,00	1,78	3,57	5,39	7,25	9,14	10,94	12,56	14,08	15,34	16,34
106324	11,50	-1,592	0,00	1,74	3,50	5,27	7,10	8,97	10,81	12,52	14,06	15,26	16,26
117328	12,50	-1,592	0,00	1,72	3,45	5,21	7,00	8,85	10,71	12,49	13,97	15,18	16,14
128652	13,50	-1,592	0,00	1,71	3,43	5,17	6,95	8,77	10,64	12,44	13,88	15,08	15,98
140329	14,50	-1,592	0,00	1,71	3,43	5,17	6,93	8,74	10,61	12,33	13,78	14,94	15,80
152395	15,50	-1,592	0,00	1,72	3,44	5,18	6,94	8,74	10,56	12,20	13,64	14,76	15,60
164851	16,50	-1,592	0,00	1,73	3,46	5,20	6,96	8,77	10,48	12,08	13,47	14,55	15,37
177635	17,50	-1,592	0,00	1,74	3,49	5,24	7,01	8,78	10,41	11,94	13,25	14,30	15,12
190689	18,50	-1,592	0,00	1,76	3,52	5,28	7,07	8,76	10,34	11,76	13,00	14,03	14,85
203979	19,50	-1,592	0,00	1,78	3,55	5,34	7,10	8,72	10,24	11,56	12,73	13,73	14,56
217490	20,50	-1,592	0,00	1,80	3,60	5,40	7,09	8,68	10,10	11,34	12,45	13,42	14,26

4 ZONA ESTANCA DEL BUQUE

En esta apartado se define la zona estanca del buque, aquella que no tiene aberturas al exterior y si las hubiese estarían cerradas de manera estanca.

En un buque portacontenedores la zona estanca se extiende hasta la cubierta superior, incluyendo también las escotillas estancas. También se considera zona estanca la superestructura hasta la altura del puente.

Se muestra a continuación un esquema de la misma:

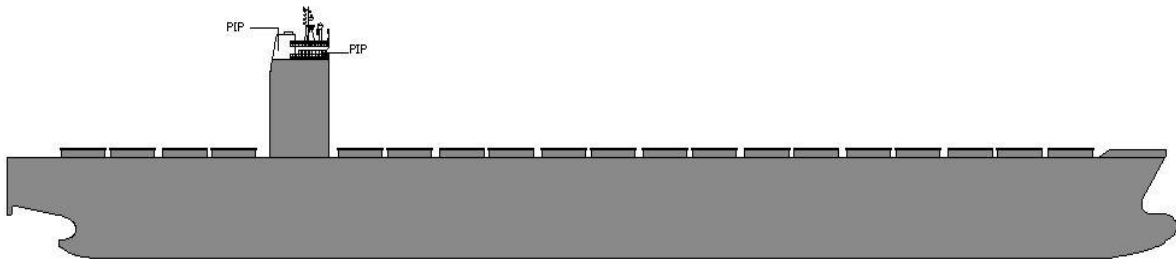

5 PUNTOS DE INUNDACIÓN PROGRESIVA DEL BUQUE

Los puntos de inundación progresiva son aquellos puntos donde existen aperturas en nuestro buque que dan acceso al interior.

En el caso de nuestro buque esos puntos son las ventilaciones de cámara de máquinas y la entrada al puente en lo más alto de la superestructura.

Las coordenadas de los puntos de inundación (babor y estribor) son los siguientes:

- VENTILACIÓN CÁMARA DE MÁQUINAS:

LONGITUDINAL	72,4 m
TRANSVERSAL	5,8 m
VERTICAL	52,2 m

LONGITUDINAL	72,4 m
TRANSVERSAL	- 5,8 m
VERTICAL	52,2 m

- ENTRADA HABILITACIÓN:

LONGITUDINAL	78,7 m
TRANSVERSAL	10,9 m
VERTICAL	52,2 m

LONGITUDINAL	78,7 m
TRANSVERSAL	- 10,9 m
VERTICAL	52,2 m

Se muestra a continuación un esquema de los puntos de inundación:

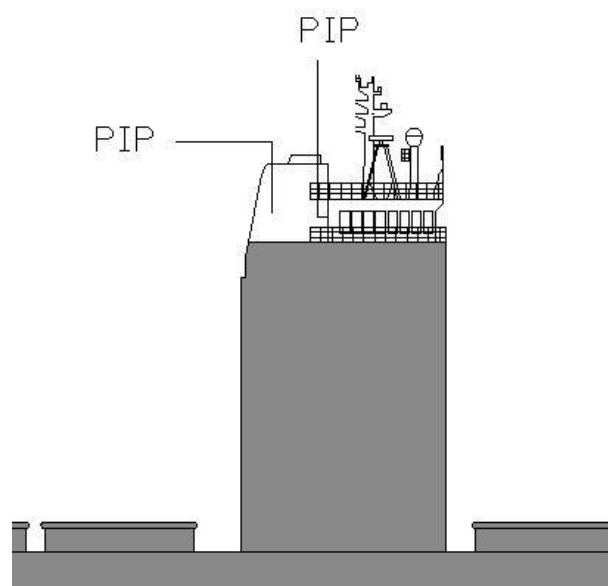

6 JUSTIFICACIÓN DEL COMPARTIMENTADO

6.1 COMPARTIMENTADO LONGITUDINAL

La disposición de los mamparos longitudinales será la siguiente:

ZONA	SEPARACION CUADERNAS,	CUADERNAS		DIF	EXTENSIÓN	
PIQUE DE POPA	0,680	-10	23	33	-6,88	15,60
BODEGA 1 - 1	0,740	14	32	18	9,19	21,77
COFFERDAM 1	0,740	32	34	2	21,77	23,25
BODEGA 1 - 2	0,740	34	51	17	23,25	35,83
COFFERDAM 2	0,740	51	54	3	35,83	38,05
BODEGA 2 - 3	0,740	54	71	17	38,05	50,63
AGUA DULCE / AGUA TÉCNICA	0,740	71	73	2	50,92	52,40
BODEGA 2 - 4	0,740	73	90	17	52,40	64,98
CÁMARA DE MÁQUINAS	0,740	90	120	30	64,98	87,18
FUEL OIL 1	0,740	120	123	3	87,18	89,40
BODEGA 3 - 5	0,740	123	140	17	89,40	101,98
COFFERDAM 5	0,740	140	142	2	101,98	103,46
BODEGA 3 - 6	0,740	142	159	17	103,46	116,04
FUEL OIL 2	0,740	159	162	3	116,04	118,26
BODEGA 4 - 7	0,740	162	179	17	118,26	130,84
COFFERDAM 7	0,740	179	181	2	130,84	132,32
BODEGA 4 - 8	0,740	181	198	17	132,32	144,90
FUEL OIL 3	0,740	198	201	3	144,90	147,12
BODEGA 5 - 9	0,740	201	218	17	147,12	159,70
COFFERDAM 9	0,740	218	220	2	159,70	161,18
BODEGA 5 - 10	0,740	220	237	17	161,18	173,76
FUEL OIL 4	0,740	237	240	3	173,76	175,98
BODEGA 6 - 11	0,740	240	257	17	175,98	188,56
COFFERDAM 11	0,740	257	259	2	188,56	190,04
BODEGA 6 - 12	0,740	259	276	17	190,04	202,62
DIESEL 1	0,740	276	279	3	202,62	204,84
BODEGA 7 - 13	0,740	279	296	17	204,84	217,42
COFFERDAM 13	0,740	296	298	2	217,42	218,90
BODEGA 7 - 14	0,740	298	315	17	218,90	231,48
COFFERDAM 14	0,740	315	318	3	231,48	233,70
BODEGA 8 - 15	0,740	318	335	17	233,70	246,28
COFFERDAM 15	0,740	335	337	2	246,28	247,76
BODEGA 8 - 16	0,740	337	354	17	247,76	260,34
COFFERDAM 16	0,740	354	356	2	260,34	261,82
BODEGA 9 - 17	0,740	356	373	17	261,82	274,40
COFFERDAM 17	0,740	373	375	2	274,40	275,88
BODEGA 9 - 18	0,740	375	392	17	275,88	288,46
COFFERDAM 18	0,740	392	394	2	288,46	289,94
PROPULSOR DE PROA / BODEGA 10 - 19	0,680	394	413	19	289,94	304,00
PIQUE DE PROA	0,680	413	445	32	304,00	333,37

La separación será menor en las zonas de proa y popa, con 680 mm, que en la sección cilíndrica del buque, con 740 mm.

Las bodegas se han dispuesto de tal modo que permitan almacenar 2 contenedores de 6,1 m (20 ft, TEU) longitudinalmente, con una separación entre ellos de 0,050 m. y 0,180 m. en los extremos de proa y popa de cada una. Se ocuparán tanques verticales con fuel oil, diésel y agua dulce entre bodegas.

- **COMPROBACIÓN DEL MAMPARO DE COLISIÓN**

El pique de proa es la zona que se sitúa a proa del mamparo de colisión. La posición de este mamparo queda determinado por las reglas del *Lloyd's Register 2015* (P3; Ch3; 4.2.1.) y por el reglamento SOLAS, Capítulo II Regla 12.

Siguiendo lo establecido en los reglamentos citados, se instalará un mamparo de colisión que será estanco hasta la cubierta de cierre. Este mamparo estará situado a una distancia de la perpendicular de proa no inferior a $0,05LF$ o a 10 m, si esta segunda magnitud es menor, y, salvo cuando la Administración permita otra cosa, dicha distancia no será superior a $0,08LF$ o $0,05LF + 3$ m, si esta segunda magnitud es mayor.

Cuando cualquier parte del buque que quede debajo de la flotación se prolongue por delante de la perpendicular de proa, como por ejemplo ocurre con el bulbo de este buque, las distancias estipuladas en el primer párrafo se medirán desde un punto situado:

- A mitad de la protuberancia del bulbo.
- A una distancia igual a $0,015LF$ por delante de la perpendicular de proa.
- A una distancia de 3 m por delante de la perpendicular de proa.

Tomándose de estas medidas la menor.

Se define la eslora LF , como el 96% de la eslora total medida en una flotación cuya distancia a la cara superior de la quilla sea igual al 85% del puntal mínimo de trazado, o la eslora medida en esa flotación desde la cara proel de la roda hasta el eje de la mecha del timón, si esta segunda magnitud es mayor:

$$L_F = \max \{0,96 \times 329,84; 322,96\} = \max \{316,64; 322,96\} = \mathbf{322,96}$$

En primer lugar se determinan los valores de las tres distancias anteriores:

$$\begin{aligned}x &= 0,5 \times 7,64 = 3,82 \text{ m} \\x &= 0,015 \times 322,96 = 4,84 \text{ m} \\x &= 3 \text{ m}\end{aligned}$$

Por lo tanto, el punto de referencia será 3 metros. A continuación calcularemos un intervalo dentro del cual deberá situarse el mamparo de colisión:

$$x_{max} = \max \{0,08 \times 322,9; 0,05 \times 322,9 + 3\} = \max \{25,83; 19,14\} = 25,83 \text{ m}$$

$$x_{min} = \min \{0,05 \times 322,9; 10\} = \min \{16,13; 10\} = 10 \text{ m}$$

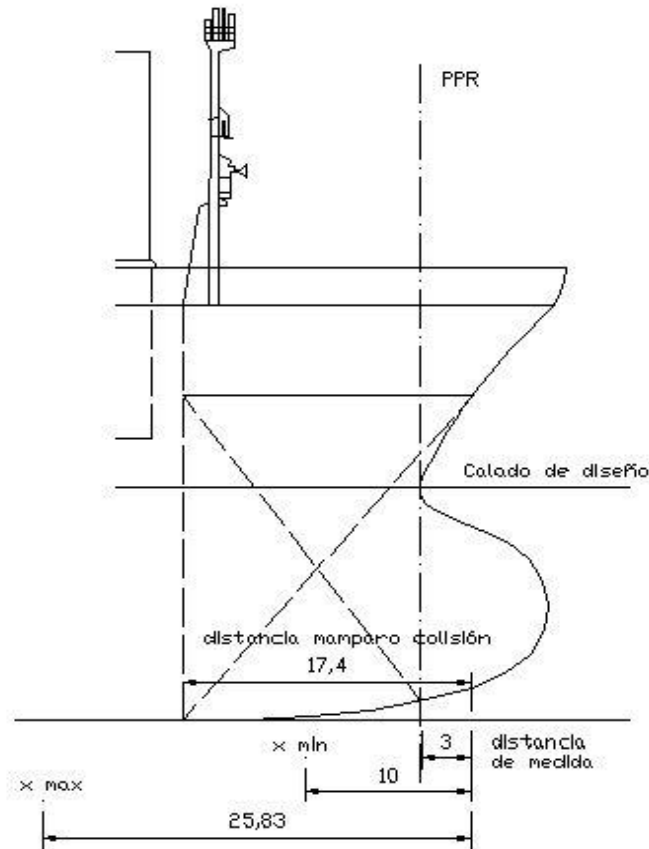

6.2 COMPARTIMENTADO VERTICAL

La disposición del compartimentado vertical será la siguiente:

- DOBLE FONDO:

El doble fondo tendrá una altura de 2 m sobre la línea base.

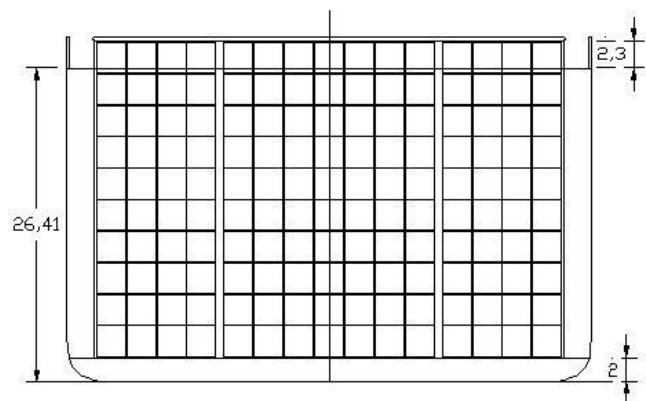

- VOLUMEN DE BODEGA:

El volumen de bodega irá desde el doble fondo hasta 28,71 m, ya que se prolonga por encima de la cubierta superior (26,41 m) 2,30 m debido a la altura de las brazolas. Se podrán alojar 10 contenedores en puntal de 8,5 ft (2,59 m), teniendo

en cuenta un margen superior para la flexión de las tapas de escotilla de 0,50 m y márgenes entre contenedores de 0,05 m.

6.3 COMPARTIMENTADO TRANSVERSAL

Transversalmente el buque posee un doble casco que variará con la sección que se considere, ya que está adaptado según las diferentes disposiciones de los contenedores, de 8 ft (2,438 m), a lo largo del buque.

La manga media será de 2,39 m pero variará ligeramente en función de la manga a lo largo del buque como se muestra en el croquis.

Se adjuntan en el Anexo IV las diferentes secciones transversales del buque donde se aprecia la configuración del doble casco así como la estiba de contenedores a los distintos niveles.

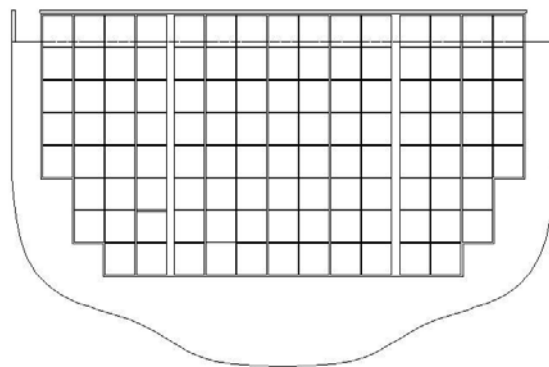

7 JUSTIFICACIÓN DE LAS CAPACIDADES DE TANQUES Y BODEGAS

Las capacidades que se determinarán son las siguientes:

- Tanques de Combustible.
- Tanques de Agua Dulce.
- Tanques de Aceite.
- Tanques de Lastre.
- Otros Tanques.
- Contenedores en bodega.

7.1 TANQUES DE COMBUSTIBLE

Se calcularán las capacidades del combustible Fuel-Oil total así como el necesario para uso diario y el de sedimentación.

7.1.1 TANQUES ALMACÉN DE COMBUSTIBLE

En primer lugar se calculan las toneladas de Fuel-Oil necesarias contando con el consumo tanto del motor principal como de los auxiliares:

$$C_{Combustible} = C_e \times BKW \times \frac{\text{autonomía}}{v \times 10^3}$$

donde C_e es el consumo de la planta propulsora, y BKW es la potencia total.

Se ha escogido un motor propulsor MAN modelo K90ME-C9-TII de 12 cilindros, con una potencia de 68.640 kW ya que es la potencia, de los motores ofertados en el mercado que más se acerca a la potencia estimada para nuestro buque 66.570 kW. Además de motor principal tendremos cuatro motores auxiliares de 2.534 kW cada uno, calculados en el Cuaderno 11.

Se adjunta la información sobre el motor como Anexo III.

$$C_e = 0,171 \frac{kg}{kW \times h}$$

$$BKW = BKW_{motor} + BKW_{auxiliares} = 68640 + 4 \times 2534 = 78776 kW$$

El buque proyecto tendrá una autonomía de 12.000 millas a 25,5 nudos.

Así tenemos que el consumo de combustible total será:

$$C_{Combustible} = 0,171 \times 78776 \times \frac{12000}{25,5 \times 10^3} = 6339 ton.$$

Aplicando un margen del 10% obtenemos que la capacidad de los tanques de combustible no puede ser menor de:

$$C_{Combustible} = 6973 ton.$$

7.1.2 TANQUES DE USO DIARIO

Los tanques de combustible de uso diario tienen capacidad suficiente para almacenar 24 horas de consumo de combustible. Este se almacenará en dos tanques:

$$C_{Cusodiario} = 24 h \times C_e \times BKW \times 10^{-3}$$

$$C_{Cusodiario} = 24 \times 0,171 \times 78776 \times 10^{-3} = 323 ton.$$

7.1.3 TANQUES DE SEDIMENTACIÓN

Se estimará una capacidad de 36 horas de consumo de combustible con un margen del 10% debido a que los lodos que se acumulan en su fondo son mayores. Este se almacenará en dos tanques como mínimo.

$$C_{Csedimentación} = 36 h \times C_e \times BKW \times 10^{-3}$$

$$C_{Csedimentación} = 36 \times 0,171 \times 78776 \times 10^{-3} = 485 ton.$$

Aplicando un margen del 10% obtenemos:

$$C_{Csedimentación} = 534 ton.$$

7.2 TANQUES DE DIÉSEL

Incluye el consumo Diésel Oil para arranque parada y maniobra de los motores principales y consumo en la estancia en puerto. Además, debido a que nuestro buque pasará por las costas del Norte de Europa cuyas costas están denominadas como zonas ECA, será necesaria una cantidad de combustible a mayores para el paso por esas zonas de aproximadamente 3 días.

Se dispondrá de un tanque con una capacidad estimada de 5 días de navegación.

$$CDiesel = 120 h \times Ce \times BKW \times 10^{-3}$$

$$CDiesel = 120 \times 0,171 \times 78776 \times 10^{-3} = \mathbf{1617 ton.}$$

7.2.1 TANQUES DIÉSEL DE USO DIARIO

Los tanques de diésel de uso diario tienen capacidad suficiente para almacenar 24 horas de consumo de combustible. Este se almacenará en dos tanques:

$$CCusodiario = 24 h \times Ce \times BKW \times 10^{-3}$$

$$CCusodiario = 24 \times 0,171 \times 78776 \times 10^{-3} = \mathbf{324 ton.}$$

7.2.2 TANQUES DIÉSEL DE SEDIMENTACIÓN

Se estimará una capacidad de 36 horas de consumo de diésel con un margen del 10% debido a que los lodos que se acumulan en su fondo son mayores. Este se almacenará en dos tanques como mínimo.

$$CCsedimentación = 36 h \times Ce \times BKW \times 10^{-3}$$

$$CCsedimentación = 36 \times 0,171 \times 78776 \times 10^{-3} = \mathbf{485 ton.}$$

Aplicando un margen del 10% obtenemos:

$$CCsedimentación = \mathbf{534 ton.}$$

7.3 TANQUES DE AGUA DULCE

Los tanques de agua dulce se diferencian en tanques de agua potable, necesaria para la tripulación y tanques de agua técnica.

7.3.1 TANQUES DE AGUA POTABLE

Para el cálculo de la capacidad de estos tanques será necesario primero estimar la duración de la travesía más larga a realizar. El buque proyecto dispone de 28 tripulantes y de una autonomía de 12.000 millas a 25,5 nudos de velocidad.

Con esto se calcularán los días de viaje:

$$t = \frac{\text{autonomía}}{\text{velocidad}} = \frac{12000 \text{ millas}}{25,5 \text{ kn}} = 471 \text{ horas} = 20 \text{ días}$$

Para el dimensionamiento de este tanque se recurrirá a la norma UN-ISO 15748-2, donde en su tabla A.1 nos da la cantidad de agua potable por persona y día para diferentes tipos de buques.

Tabla A.1
Valores guía para el consumo de agua potable en litros por persona/cama y día

Tipo de buque		Grupo de personas embarcado	Consumo de agua cuando esté equipado con	
			sistema de aseos de gravedad	sistema de aseos de vacío
Buque de alta mar	Carguero	Tripulante/cama	220 l	175 l
	Buque de pasaje	Pasajero/cama	270 l	225 l
	Crucero de lujo	Pasajero/cama	–	275 l
	Trasbordador con cabinas	Pasajero/cama	205 l ^a	160 l ^a
		Pasajero sin cama	100 l	55 l
	Trasbordador sin cabinas	Pasajero sin cama	150 l	105 l
Tripulante sin cama		100 l	55 l	
Embarcación de navegación interior	Carguero	Tripulante/cama	mínimo 150 l	
	Buque de pasaje con cabinas	Pasajero/tripulante/cama	220 l	175 l
	Buque de pasaje sin cabinas	Tripulante/pasajero	100 l	
Buques especiales	Buque de investigación	por cama	220 l	175 l
	Buque auxiliar de las fuerzas armadas y mayores	Tripulante/cama	160 l	110 l
	Buque de las fuerzas armadas menor que un auxiliar	Tripulante/cama	100 l	55 l
Pesquero		Tripulante/cama	mínimo 150 l	
Plataforma "offshore"		Tripulante/cama	350 l	
^a Sin lavandería a bordo.				

En nuestro caso no interesa el apartado para buques de carga de alta mar, en el caso de un sistema de aseos de vacío, por lo que el consumo de agua por persona y día será de 175 l.

Por tanto, para dimensionar el tanque de agua potable, haremos el siguiente cálculo:

$$CAP = 20 \text{ días} \times 28 \text{ personas} \times 175 \frac{\text{litros}}{\text{pers} \times \text{día}} \times 10^3 = 98 \text{ m}^3 = 98 \text{ ton}$$

7.3.2 AGUA TÉCNICA

En cuanto al agua dulce técnica usaremos la tabla A.2 de la misma norma, la cual se muestra a continuación:

Tabla A.2
Valores guía del consumo de agua en diferentes puntos de servicio por persona y día para buques de carga

Punto de servicio	Consumo por cada utilización l	Frecuencia de uso por día	Consumo		
			Cantidad total de agua l/día	Agua fría l/día	Agua caliente ^a l/día
Lavabo de pared o pedestal	2	6 ×	12	5	7
Plato de ducha	60	2 ×	120	50	70
Retrete de gravedad ^b	10	6 ×	60	60	–
Retrete de vacío ^b	1,2	6 ×	8	8	–
Urinario ^b	3	5 ×	15 ^c	15 ^c	–
Zona de cocina	–	–	20	8	12
Lavandería ^b	–	–	38	15 ^d	23
Limpieza	–	–	5	2	3

^a Temperatura de 60 °C en la admisión de agua caliente.
^b Si se utiliza agua no potable se reduce el consumo de agua potable proporcionalmente.
^c El uso de urinarios reduce la utilización de retretes.
^d Consumo de los aparatos con conexiones al agua caliente.

Si sumamos los consumos totales, teniendo en cuenta que utilizamos un sistema de retretes por vacío, tendremos un total de 180 l por agua y día de agua técnica. Por tanto, el total de agua técnica será:

$$CAT = 20 \text{ días} \times 28 \text{ personas} \times 180 \frac{\text{litros}}{\text{pers} \times \text{día}} \times 10^3 = 100 \text{ m}^3 = 100 \text{ ton}$$

7.4 TANQUES DE ACEITE

Para el cálculo de capacidades de tanques de aceite será necesario observar la guía del fabricante de la planta propulsora, MAN modelo K90ME-C9-TII. De las especificaciones técnicas se extraen los siguientes consumos específicos:

- Sistema de aceite, 60,3 kg/día.
- Lubricación de cilindros, 0,60 kg/kW h.

Para poder obtener un consumo específico total:

$$ce = ce1 + ce2$$
$$ce1 = 60,3 \frac{kg}{día} \times \frac{1 \text{ día}}{24 \text{ h}} \times \frac{1}{78776 \text{ kW}} = 3,15 \times 10^{-5} \frac{kg}{kW \times h}$$

$$ce2 = 0,60 \frac{g}{kW \times h} \times \frac{1 \text{ kg}}{1000 \text{ g}} = 6 \times 10^{-4} \frac{kg}{KW \times h}$$

$$ce = 6,3 \times 10^{-4}$$

Una vez conocido el consumo específico es posible calcular las toneladas de aceite necesarias:

$$CAceite = 471 \text{ h} \times Ce \times BKW \times 10^{-3}$$

$$CAceite = 471 \times 6,3 \times 10^{-4} \times 78776 \times 10^{-3} = \mathbf{23,5 \text{ ton}}$$

7.5 OTROS TANQUES

7.5.1 TANQUES DE LODOS

De acuerdo con MARPOL, Anexo I, Capítulo 3, Parte A, Regla 12: "Todo buque de arqueo bruto igual o superior a 400 tendrá un tanque o tanques de capacidad suficiente, habida cuenta del tipo de maquinaria con que esté equipado y la duración de sus viajes, para recibir los residuos de hidrocarburos (fangos) que no sea posible eliminar de otro modo cumpliendo las prescripciones del presente anexo, tales como los resultantes de la purificación de los combustibles y aceite lubricantes y de las fugas de hidrocarburos que se producen en los espacios de máquinas".

Según la interpretación 15.1 a dicha regla:

1. *“Respecto de los buques que no lleven agua de lastre en los tanques de combustible líquido, la capacidad mínima del tanque de fangos (V1) será calculada conforme a la fórmula siguiente (...).”*

2. *“Cuando tales buques estén provistos de homogeneizadores, incineradores de fangos y otros medios reconocidos para la eliminación de fangos a bordo, la capacidad mínima del tanque de fangos (V1) será, en lugar de la antedicha, la siguiente: $V1 = 1 \text{ m}^3$ para buques de arqueo bruto igual o superior a 400 pero inferior a 4000, o 2 m^3 para buques de arqueo bruto igual o superior a 4000.”*

Por lo tanto, la capacidad necesaria del tanque de lodos será como mínimo de 2 m³. Se dispondrán dos tanques de lodos, con una capacidad de 4 m³ cada uno, en el doble fondo de la cámara de máquinas, dejando un margen con el fondo del buque.

7.5.2 TANQUES DE AGUAS RESIDUALES

De acuerdo con el MARPOL Anexo IV, Capítulo 3, Regla 9: *“Todo buque que, de conformidad con lo dispuesto en la regla 2, esté sujeto a las disposiciones del presente anexo estará equipado con uno de los siguientes sistemas de tratamiento de aguas sucias:*

1. *Una instalación de tratamiento de aguas sucias aprobada por la Administración, teniendo en cuenta las normas y los métodos de prueba elaborados por la Organización, o*
2. *Un sistema para desmenuzar y desinfectar las aguas sucias aprobado por la Administración. Este sistema estará dotado de medios que, a juicio de la Administración, permitan almacenar temporalmente las aguas sucias cuando el buque esté a menos de 3 millas marinas de la tierra más próxima, o*
3. *Un tanque de retención que tenga capacidad suficiente, a juicio de la Administración, para retener todas las aguas sucias, habida cuenta del servicio que presta el buque, el número de personas a bordo y otros factores pertinentes. El tanque de retención estará construido del modo que la Administración juzgue satisfactorio y estará dotado de medios para indicar visualmente la cantidad del contenido.”*

En el buque proyecto se dispondrá una instalación de tratamiento de aguas residuales y de un tanque de almacenamiento de aguas residuales. Para definir la capacidad del tanque se tiene en cuenta lo definido en la norma UNE-EN ISO 15749-1:2004 y en UNE-EN ISO 15749-2:2004:

8 TANQUE COLECTOR Y PLANTA DE TRATAMIENTO DE AGUAS NEGRAS

Para el diseño de los tanques o de las plantas de tratamiento de aguas negras, se tiene que tener en cuenta lo siguiente:

- el volumen mínimo de aguas de desecho de acuerdo con la Norma ISO 15749-1:2004, tabla 2;
- si es necesario, el volumen distinto del volumen mínimo de aguas de desecho;
- bien sea necesario o acordado, el tiempo de mantenimiento de las aguas de desecho en los tanques o en las plantas de tratamiento dependiendo del tráfico efectuado por el buque;
- los requisitos generales que figuran en la Norma ISO 15749-1.

4.3 Cantidad de agua de desecho

Cuando se diseña una planta, hay que considerar las cantidades mínimas de agua de desecho de acuerdo con la tabla 2.

Tabla 2
Cantidad mínima de agua de desecho

Tipo de buque	Cantidad mínima de agua de desecho por persona y día en litros			
	Planta sin vacío		Planta con vacío	
	Aguas negras	Aguas negras y grises	Aguas negras	Aguas negras y grises
Buques de pasaje	70	230	25	185
Buques de alta mar exceptuando los de pasaje	70	180	25	135
Los buques costeros pueden conservar los valores recomendados por las autoridades responsables.				
NOTA— Estos valores son los recomendados. Hay que considerar las posibles variaciones debidas a los reglamentos nacionales o a las recomendaciones de las sociedades de clasificación.				

Según esto la capacidad necesaria será:

$$CA_{Residuales} = 28 \text{ personas} \times 180 \text{ l} = 5 \text{ ton}$$

Se dispondrán dos tanques residuales simétricos con una capacidad de 5 toneladas cada uno.

7.5.3 TANQUES DE ACEITE USADO

Se dispondrán dos tanques para aceites en el doble fondo de la cámara de máquinas, dejando un margen con el fondo del buque, de 24 toneladas cada uno.

7.6 TANQUES DE LASTRE

La capacidad de los tanques de lastre debe ser suficiente como para que en una situación de navegación sin carga se garantice la inmersión de la hélice.

Para que se sumerja la hélice es necesario un calado mínimo en popa:

$$T_{PP} \min = MI \times D_H \times MS$$

siendo:

- MI , el margen inferior de la hélice para evitar daños. Se toma a partir del Cuaderno 3 un valor de 0,38 m.
- Dh , el diámetro de la hélice, 9,7 m.
- MS , el margen superior. Se ha estimado un valor de 0,15 m.

$$T_{PP} \min = 0,38 + 9,7 + 0,15 = 10,23 \text{ m.}$$

Para asegurar la inmersión de la hélice se supone un trimado positivo igual al 1% de la eslora entre perpendiculares.

$$t = \frac{1}{100} \times L_{PP} = \frac{1}{100} \times 318,4 = 3,184 \text{ m (+)}$$

A continuación utilizaremos el programa *Maxsurf Stability* para calcular un calado medio que asegure el calado en popa mayor o igual a $T_{pp} \min$. Suponemos un calado de 10,23 m en la perpendicular de popa y un trimado de 3,184 m, resultando un valor del calado medio de 8,64 m y el desplazamiento del buque correspondiente a este calado mínimo, 77.613 ton. Estos valores se obtienen de la siguiente tabla:

Draft Amidships	8,64
Displacement t	77613
Heel deg	0
Draft at FP m	7,048
Draft at AP m	10,23
Draft at LCF m	8,758
Trim (+ve by stern) m	3,184
WL Length m	317,017
Beam max extents on WL m	44,228
Wetted Area m ²	13654,1
Waterpl. Area m ²	10305,1
Prismatic coeff. (Cp)	0,633
Block coeff. (Cb)	0,621
Max Sect. area coeff. (Cm)	0,986
Waterpl. area coeff. (Cwp)	0,73
LCB from zero pt. (+ve fwd) m	148,968
LCF from zero pt. (+ve fwd) m	147,413
KB m	4,705
KG m	14,73
BMt m	17,773
BML m	739,885
GMt m	7,647
GML m	729,758
KMt m	22,478
KML m	744,553
Immersion (TPc) tonne/cm	105,627
MTc tonne.m	1779,06
RM at 1deg = GMt.Disp.sin(1) tonne.m	10357,8
Max deck inclination deg	0,573
Trim angle (+ve by stern) deg	0,573

Sabemos que el desplazamiento del buque es $\Delta = PR + PM$. El peso en rosca, PR , lo conocemos de la estimación realizada en el Cuaderno 2, 47.571 ton. El peso muerto, PM lo compondrán la carga útil, los consumos, el lastre y la tripulación y pertrechos, de modo que:

$$\Delta = PR + (\text{Consumos} + \text{Carga útil} + \text{Tripulación} + \text{Pertrechos} + \text{Lastre})$$

Para una condición de navegación sin carga y al 10% de consumos tendremos:

PESO EN ROSCA	CONSUMOS AL 10%										CONSUMOS AL 90%			TRIPULACIÓN Y PERTRECHOS
	FUEL ALMACÉN	FUEL USO DIARIO	FUEL SEDIMENTACIÓN	DIÉSEL	DIESEL USO DIARIO	DIESEL SEDIMENTACIÓN	AGUA POTABLE	AGUA TÉCNICA	ACEITE	VIVERES	LODOS	AGUAS RESIDUALES	ACEITE USADO	
47571	697,3	32,3	53,4	161,7	32,4	53,4	9,8	10	2,4	0,28	7,2	9,0	43,9	405,5

$$PM = 1.529 + Lastre$$

Así conocido el desplazamiento al calado mínimo de popa, el peso en rosca del buque y el peso muerto en la condición calculada, se obtienen las toneladas de lastre necesarias:

$$CLastre = \Delta - PR - 1.529 = 77.613 - 47.571 - 1.519 = \mathbf{28.523 \text{ ton.}}$$

7.7 CONTENEDORES EN BODEGA

Teniendo en consideración el compartimentado realizado la capacidad de las bodegas será el mostrado en la tabla a continuación.

DISPOSICIÓN DE CONTENEDORES EN BODEGA

BODEGA	ZONA	COLUMNA		RECUENTO
		A	B	
1	1	67	67	134
	2	78	78	156
2	3	93	93	186
	4	112	112	224
3	5	146	146	292
	6	150	150	300
4	7	150	150	300
	8	150	150	300
5	9	150	150	300
	10	150	150	300
6	11	150	150	300
	12	140	140	280
7	13	136	136	272
	14	124	124	248
8	15	108	108	216
	16	86	86	172
9	17	67	67	134
	18	39	39	78
10	19	32	32	64
TOTAL				4256

En bodega se disponen 4.256 TEU's como se había calculado en el Cuaderno 1.

Se adjunta como Anexo III la disposición longitudinal y transversal de los contenedores en detalle de cada bodega.

8 TABLA RESUMEN CAPACIDADES

Se muestra una tabla resumen de las capacidades obtenidas:

COMBUSTIBLE ALMACÉN	6.973 ton
COMBUSTIBLE USO DIARIO	323 ton
COMBUSTIBLE SEDIMENTACIÓN	534 ton
DIESEL	1.617 ton
DIESEL USO DIARIO	324 ton
DIESEL SEDIMENTACIÓN	534 ton
AGUA POTABLE	98 ton
AGUA TÉCNICA	100 ton
ACEITE	24 ton
LODOS	8 ton
AGUAS RESIDUALES	10 ton
ACEITE USADO	48 ton
LASTRE	28.523 ton

Conocidas las capacidades requeridas necesitamos conocer si la capacidad total de los tanques del buque, cuyas formas fueron obtenidas en el Cuaderno 3, es suficiente utilizando el programa informático *Maxsurf Stability*.

Para ello se introducen los diferentes tanques en la ventana "Room definition" con sus medidas de largo, ancho y alto y el contenido del mismo y utilizando para el cálculo la opción "Tank Calibration".

Una vez hecho el cálculo se obtendrán el volumen y las toneladas de cada tanque como se muestra la tabla resumen de la página siguiente.

NOMBRE	CANTIDAD	VOL NETO	TONELADAS NETAS	LCG	TCG	VCG
AGUA POTABLE ER	100%	57,44	57,44	51,38	7,32	8,63
AGUA POTABLE BR	100%	57,44	57,44	51,38	-7,32	8,63
AGUA TÉCNICA ER	100%	67,40	67,40	51,38	8,59	11,28
AGUA TÉCNICA BR	100%	67,40	67,40	51,38	-8,59	11,28
ACEITE ER	100%	16,17	14,88	84,98	13,41	1,63
ACEITE BR	100%	16,17	14,88	84,98	-13,41	1,63
ACEITE USADO ER	100%	30,38	27,95	84,93	6,50	1,63
ACEITE USADO BR	100%	30,38	27,95	84,93	-6,50	1,63
LODOS ER	100%	4,50	4,14	81,68	3,50	1,63
LODOS BR	100%	4,50	4,14	81,68	-3,50	1,63
AGUAS RESIDUALES ER	100%	6,75	6,75	81,68	7,25	1,63
AGUAS RESIDUALES BR	100%	6,75	6,75	81,68	-7,25	1,63
FUEL OIL USO DIARIO ER	100%	190,80	180,17	83,18	15,23	11,74
FUEL OIL USO DIARIO BR	100%	190,80	180,17	83,18	-15,23	11,74
FUEL OIL SEDIMENTACION ER	100%	286,20	270,26	73,18	15,23	11,74
FUEL OIL SEDIMENTACION BR	100%	286,20	270,26	73,18	-15,23	11,74
DIESEL USO DIARIO ER	100%	190,80	180,17	83,18	15,23	14,39
DIESEL USO DIARIO BR	100%	190,80	180,17	83,18	-15,23	14,39
DIESEL SEDIMENTACION ER	100%	286,20	270,26	73,18	15,23	14,39
DIESEL SEDIMENTACION BR	100%	286,20	270,26	73,18	-15,23	14,39
FUEL OIL 1 ER	100%	1039,02	981,14	88,29	9,62	14,48
FUEL OIL 1 BR	100%	1039,02	981,14	88,29	-9,62	14,48
FUEL OIL 2 ER	100%	1068,90	1009,36	117,15	9,86	14,21
FUEL OIL 2 BR	100%	1068,90	1009,36	117,15	-9,86	14,21
FUEL OIL 3 ER	100%	1068,90	1009,36	146,01	9,86	14,21
FUEL OIL 3 BR	100%	1068,90	1009,36	146,01	-9,86	14,21
FUEL OIL 4 ER	100%	1068,90	1009,36	174,87	9,86	14,21
FUEL OIL 4 BR	100%	1068,90	1009,36	174,87	-9,86	14,21
DIESEL 1 ER	100%	994,19	835,12	203,73	9,22	14,62
DIESEL 1 BR	100%	994,19	835,12	203,73	-9,22	14,62
LASTRE 1 ER	100%	5,72	5,86	32,64	2,36	1,51
LASTRE 1 BR	100%	5,72	5,86	32,64	-2,36	1,51
LASTRE 2 ER	100%	470,26	482,01	69,77	5,85	1,13
LASTRE 2 BR	100%	470,26	482,01	69,77	-5,85	1,13
LASTRE 3 ER	100%	966,22	990,38	102,47	10,59	1,06
LASTRE 3 BR	100%	966,22	990,38	102,47	-10,59	1,06
LASTRE 4 ER	100%	1099,64	1127,13	130,47	11,55	1,02
LASTRE 4 BR	100%	1099,64	1127,13	130,47	-11,55	1,02
LASTRE 5 ER	100%	1083,94	1111,04	159,24	11,42	1,03
LASTRE 5 BR	100%	1083,94	1111,04	159,24	-11,42	1,03
LASTRE 6 ER	100%	1004,98	1030,10	187,84	10,79	1,04
LASTRE 6 BR	100%	1004,98	1030,10	187,84	-10,79	1,04
LASTRE 7 ER	100%	759,02	778,00	215,85	8,87	1,08
LASTRE 7 BR	100%	759,02	778,00	215,85	-8,87	1,08
LASTRE 8 ER	100%	350,26	359,02	243,48	5,53	1,15
LASTRE 8 BR	100%	350,26	359,02	243,48	-5,53	1,15
LASTRE 9 ER	100%	1252,12	1283,43	277,97	4,52	7,63
LASTRE 9 BR	100%	1252,12	1283,43	277,97	-4,52	7,63
LASTRE 10 ER	100%	2022,17	2072,72	23,83	17,66	16,54
LASTRE 10 BR	100%	2022,17	2072,72	23,83	-17,66	16,54
LASTRE 11 ER	100%	3470,40	3557,16	59,90	19,06	14,15
LASTRE 11 BR	100%	3470,40	3557,16	59,90	-19,06	14,15
LASTRE 12 ER	100%	1674,80	1716,67	101,60	20,59	12,95
LASTRE 12 BR	100%	1674,80	1716,67	101,60	-20,59	12,95
LASTRE 13 ER	100%	1461,12	1497,64	130,47	20,91	12,70
LASTRE 13 BR	100%	1461,12	1497,64	130,47	-20,91	12,70
LASTRE 14 ER	100%	1633,94	1674,78	159,15	20,89	14,37
LASTRE 14 BR	100%	1633,94	1674,78	159,15	-20,89	14,37
LASTRE 15 ER	100%	1567,13	1606,31	189,55	20,10	12,26
LASTRE 15 BR	100%	1567,13	1606,31	189,55	-20,10	12,26
LASTRE 16 ER	100%	1963,23	2012,31	217,23	18,25	13,01
LASTRE 16 BR	100%	1963,23	2012,31	217,23	-18,25	13,01
LASTRE 17 ER	100%	2402,82	2462,89	246,72	13,48	12,74
LASTRE 17 BR	100%	2402,82	2462,89	246,72	-13,48	12,74
LASTRE 18 ER	100%	2000,64	2050,66	272,82	10,37	16,13
LASTRE 18 BR	100%	2000,12	2050,12	272,82	-10,37	16,13
LASTRE 19 ER	100%	495,10	507,47	295,45	9,63	20,60
LASTRE 19 BR	100%	495,10	507,47	295,45	-9,63	20,60
PIQUE DE POPA	100%	6219,234	6374,71	2,09	0,00	18,60
PIQUE DE PROA	100%	1868,68	1915,40	310,08	0,00	11,72

Los resultados completos de la calibración de los tanques obtenidos del *Maxsurf Stability* adjuntan como Anexo II.

Para finalizar se muestra una tabla comparativa de las capacidades requeridas y la capacidad total de los tanques:

TANQUE	CAPACIDAD REQUERIDA	CAPACIDAD TOTAL
COMBUSTIBLE ALMACÉN	7.068 ton	8.018 ton
COMBUSTIBLE USO DIARIO	328 ton	360 ton
COMBUSTIBLE SEDIMENTACIÓN	540 ton	541 ton
DIESEL	1.638 ton	1.670 ton
DIESEL USO DIARIO	328 ton	360 ton
DIESEL SEDIMENTACIÓN	540 ton	541 ton
AGUA POTABLE	98 ton	115 ton
AGUA TÉCNICA	100 ton	135 ton
ACEITE	24 ton	30 ton
LODOS	8 ton	8 ton
AGUAS RESIDUALES	10 ton	13,5 ton
ACEITE USADO	48 ton	56 ton
LASTRE	28.523 ton	59.454 ton

ANEXO I: CURVAS HIDROSTÁTICAS Y KN MAXSURF

Hydrostatics - formas finales COMPLETAS

Stability 20.00.05.47, build: 47

Model file: D:\Desktop\mio\6º 2015-2016\PROYECTO\Cuaderno3\NUEVAS FORMAS AFIN\formas finales COMPLETAS (Medium precision, 116 sections, Trimming on, Skin thickness not applied). Long. datum: AP; Vert. datum: Baseline. Analysis tolerance - ideal (worst case): Disp. %: 0,01000(0,100); Trim % (LCG-TCG): 0,01000(0,100); Heel % (LCG-TCG): 0,01000(0,100)

Damage Case - Intact

Fixed Trim = 3,184 m (+ve by stern)

Specific gravity = 1,025; (Density = 1,025 tonne/m³)

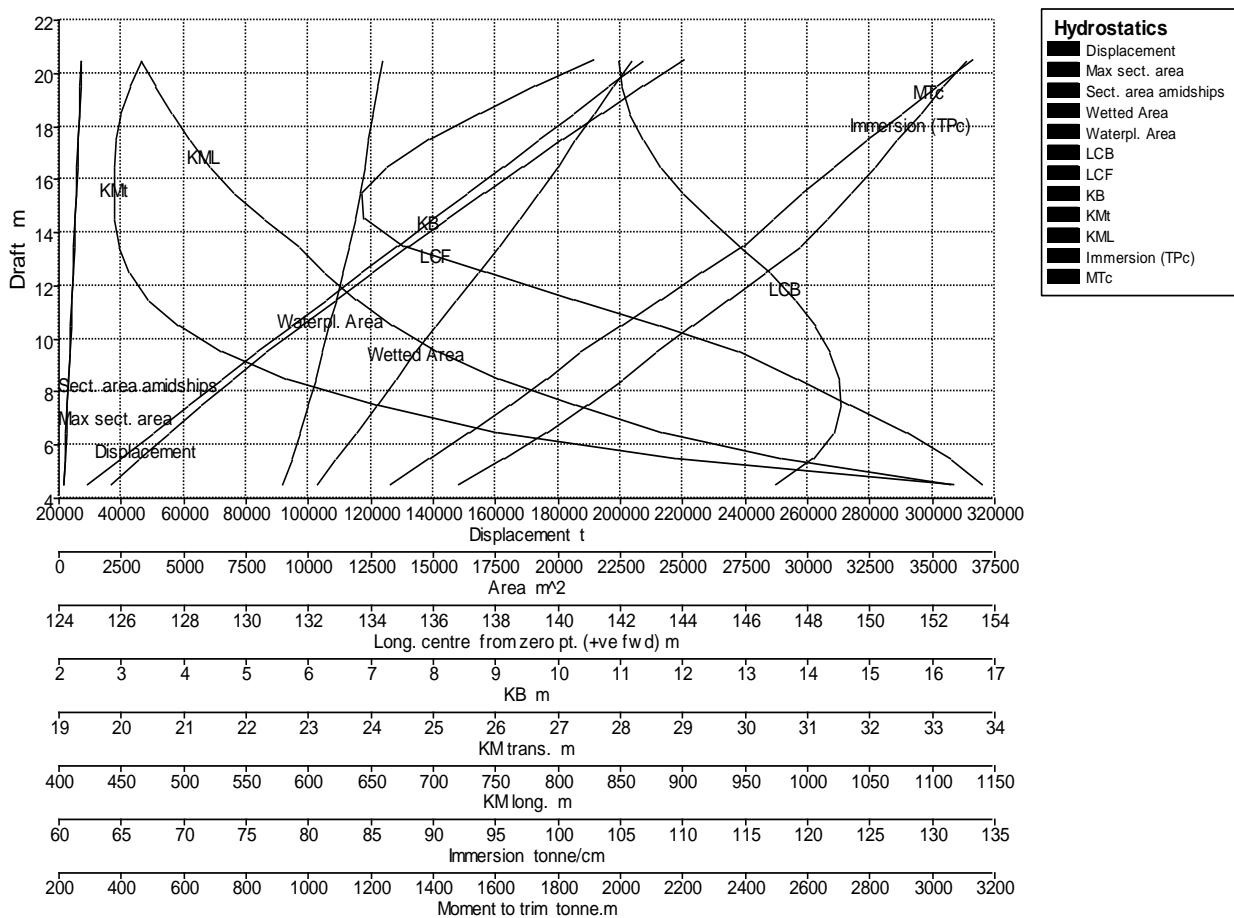

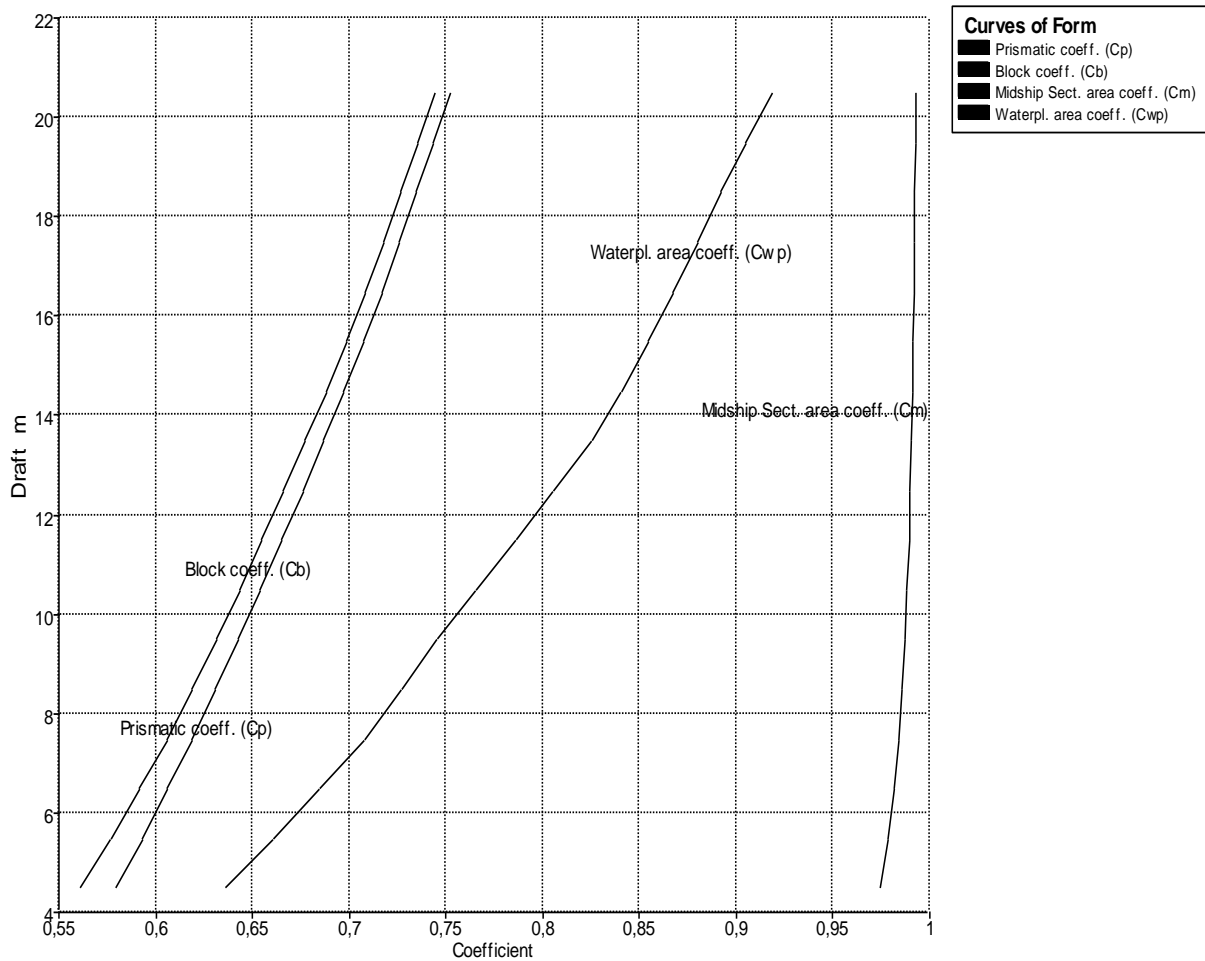

Hydrostatics - formasfinalesCOMPLETAS

Stability 20.00.05.47, build: 47

Model file: D:\Desktop\mio\6° 2015-2016\PROYECTO\Cuaderno3\NUEVAS FORMAS AFIN\formasfinalesCOMPLETAS (Medium precision, 116 sections, Trimming on, Skin thickness not applied). Long. datum: AP; Vert. datum: Baseline. Analysis tolerance - ideal(worst case): Disp. %: 0,01000(0,100); Trim%(LCG-TCG): 0,01000(0,100); Heel%(LCG-TCG): 0,01000(0,100)

Damage Case - Intact

Fixed Trim = 1,592 m (+ve by stern)

Specific gravity = 1,025; (Density = 1,025 tonne/m³)

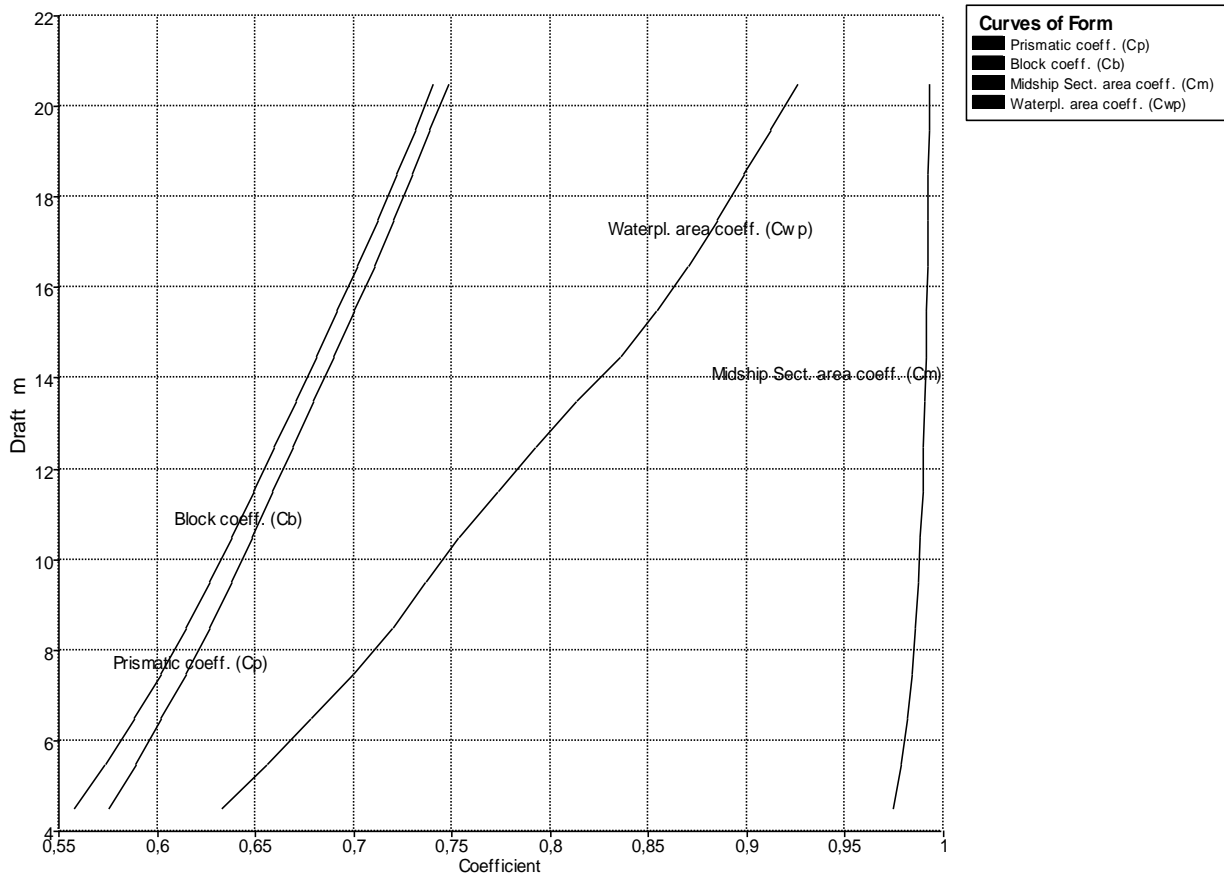
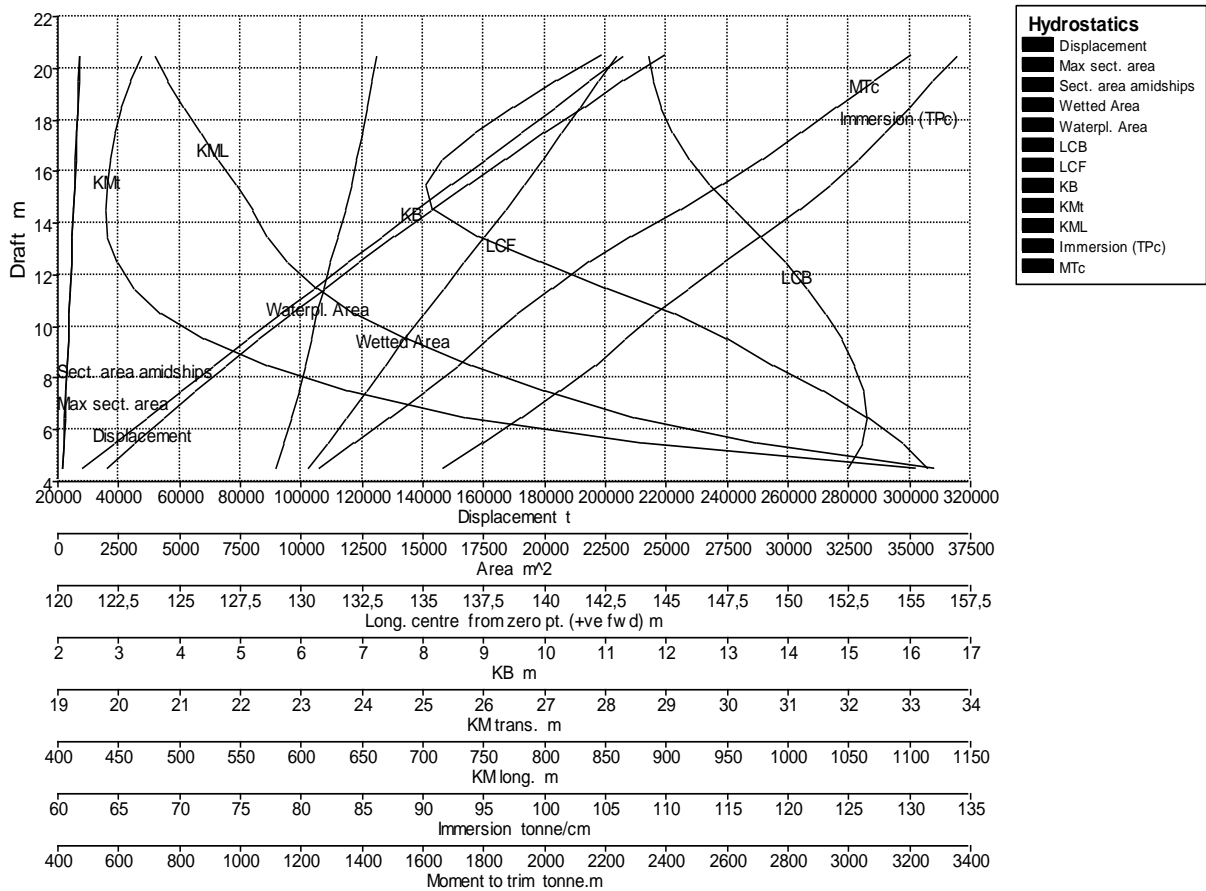

Hydrostatics - formasfinalesCOMPLETAS

Stability 20.00.05.47, build: 47

Model file: D:\Desktop\mio\6º 2015-2016\PROYECTO\Cuaderno3\NUEVAS FORMAS AFIN\formasfinalesCOMPLETAS (Medium precision, 116 sections, Trimming on, Skin thickness not applied). Long. datum: AP; Vert. datum: Baseline. Analysis tolerance - ideal(worst case): Disp.‰: 0,01000(0,100); Trim‰(LCG-TCG): 0,01000(0,100); Heel‰(LCG-TCG): 0,01000(0,100)

Damage Case - Intact

Fixed Trim = 0 m (+ve by stern)

Specific gravity = 1,025; (Density = 1,025 tonne/m³)

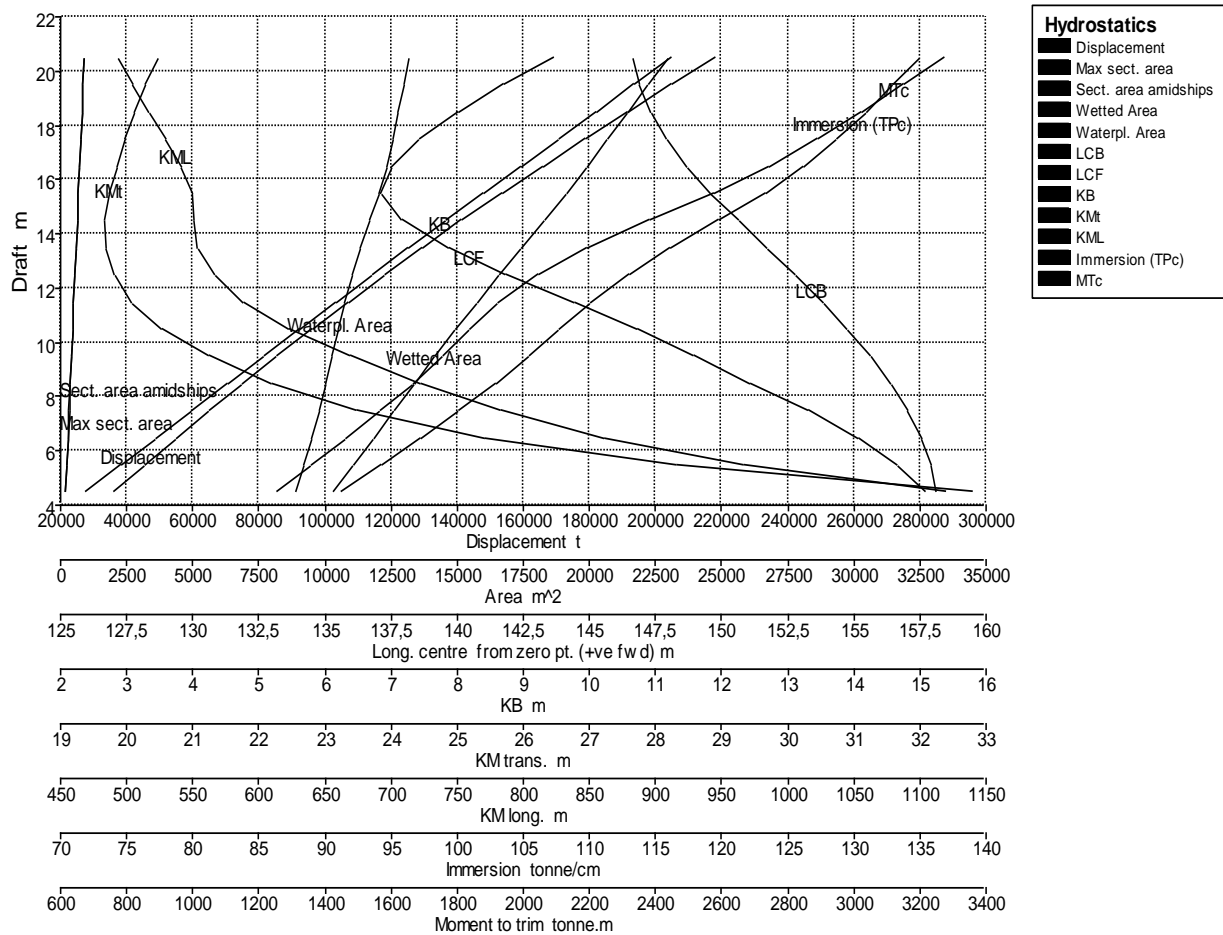

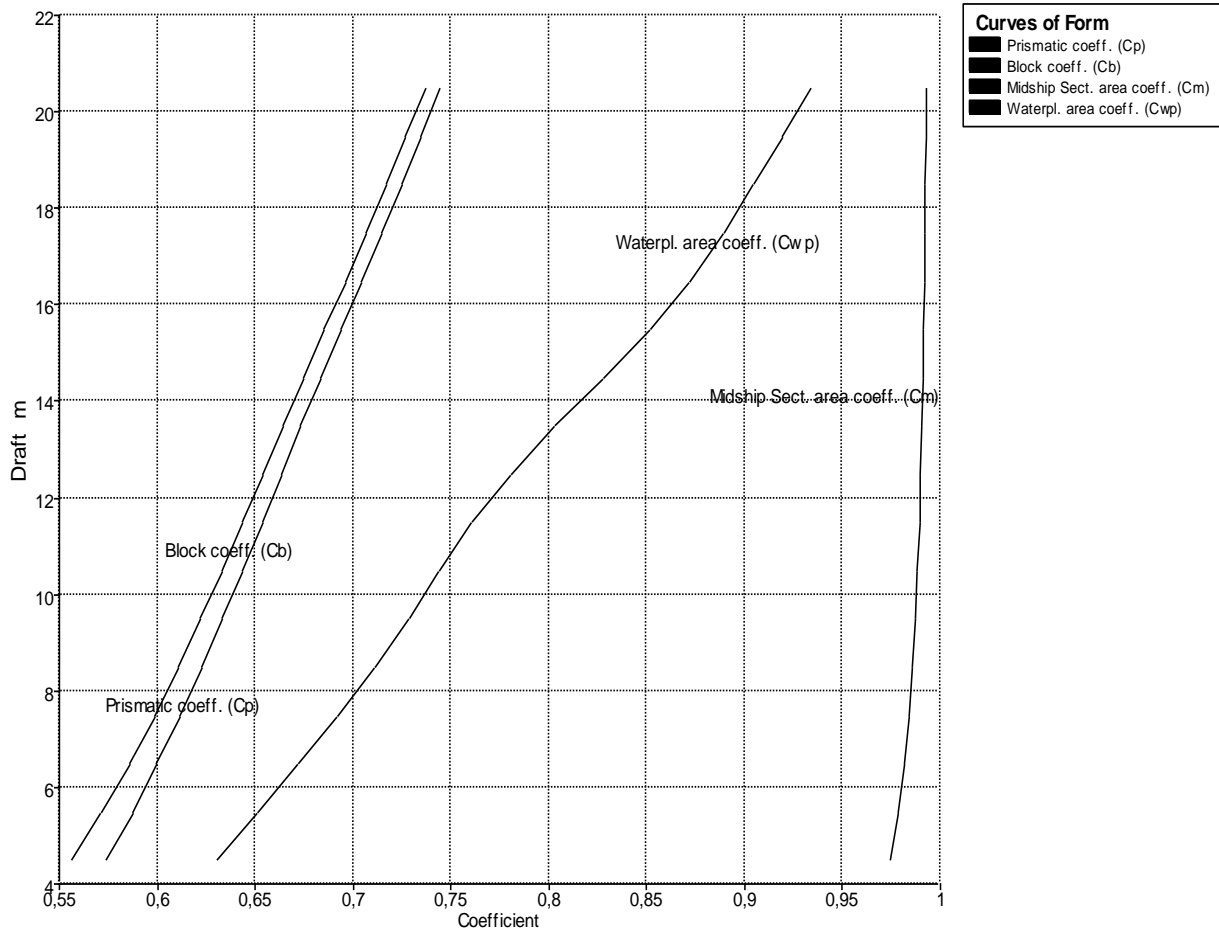

Hydrostatics - formasfinalesCOMPLETAS

Stability 20.00.05.47, build: 47

Model file: D:\Desktop\mio\6º 2015-2016\PROYECTO\Cuaderno3\NUEVAS FORMAS AFIN\formasfinalesCOMPLETAS (Medium precision, 116 sections, Trimming on, Skin thickness not applied). Long. datum: AP; Vert. datum: Baseline. Analysis tolerance - ideal(worst case): Disp.‰: 0,01000(0,100); Trim‰(LCG-TCG): 0,01000(0,100); Heel‰(LCG-TCG): 0,01000(0,100)

Damage Case - Intact

Fixed Trim = -1,592 m (+ve by stern)

Specific gravity = 1,025; (Density = 1,025 tonne/m³)

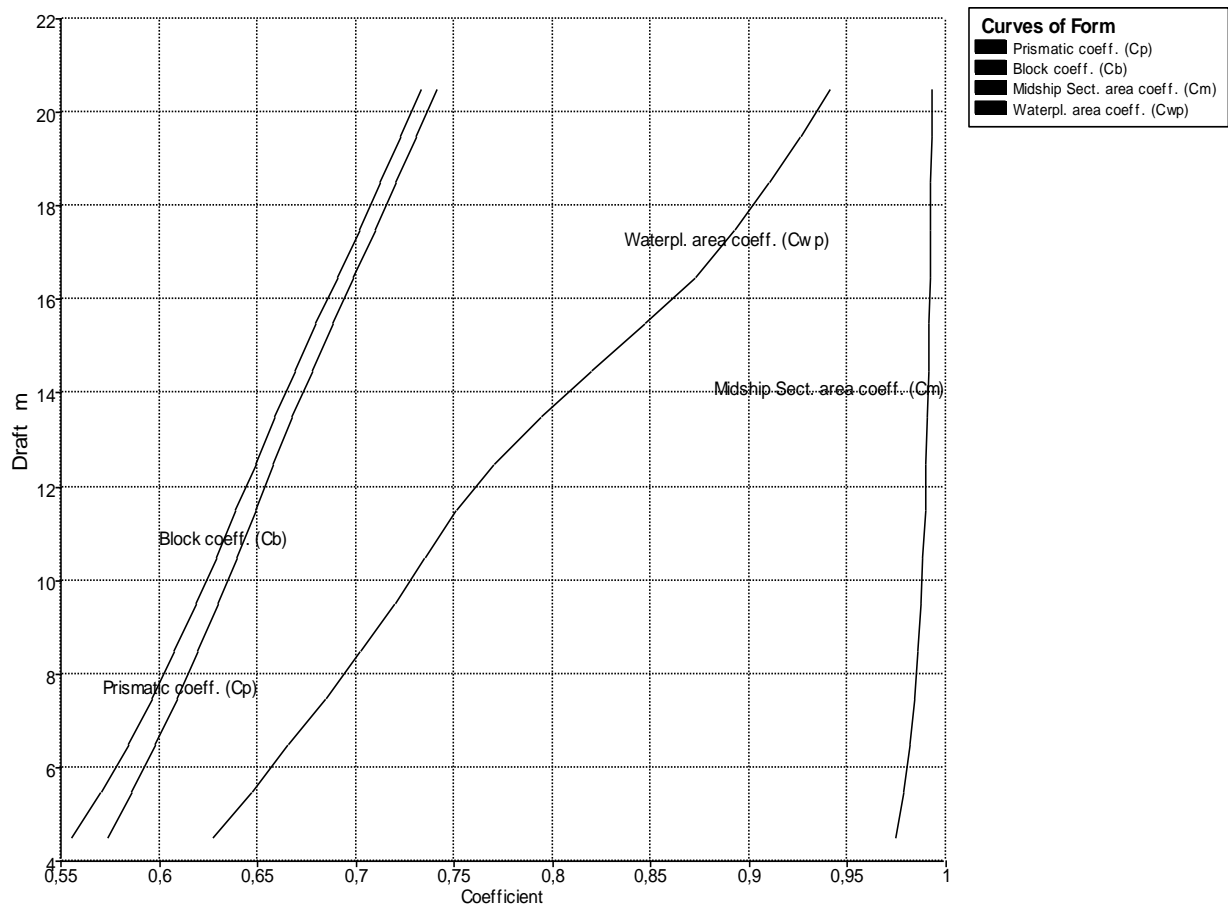
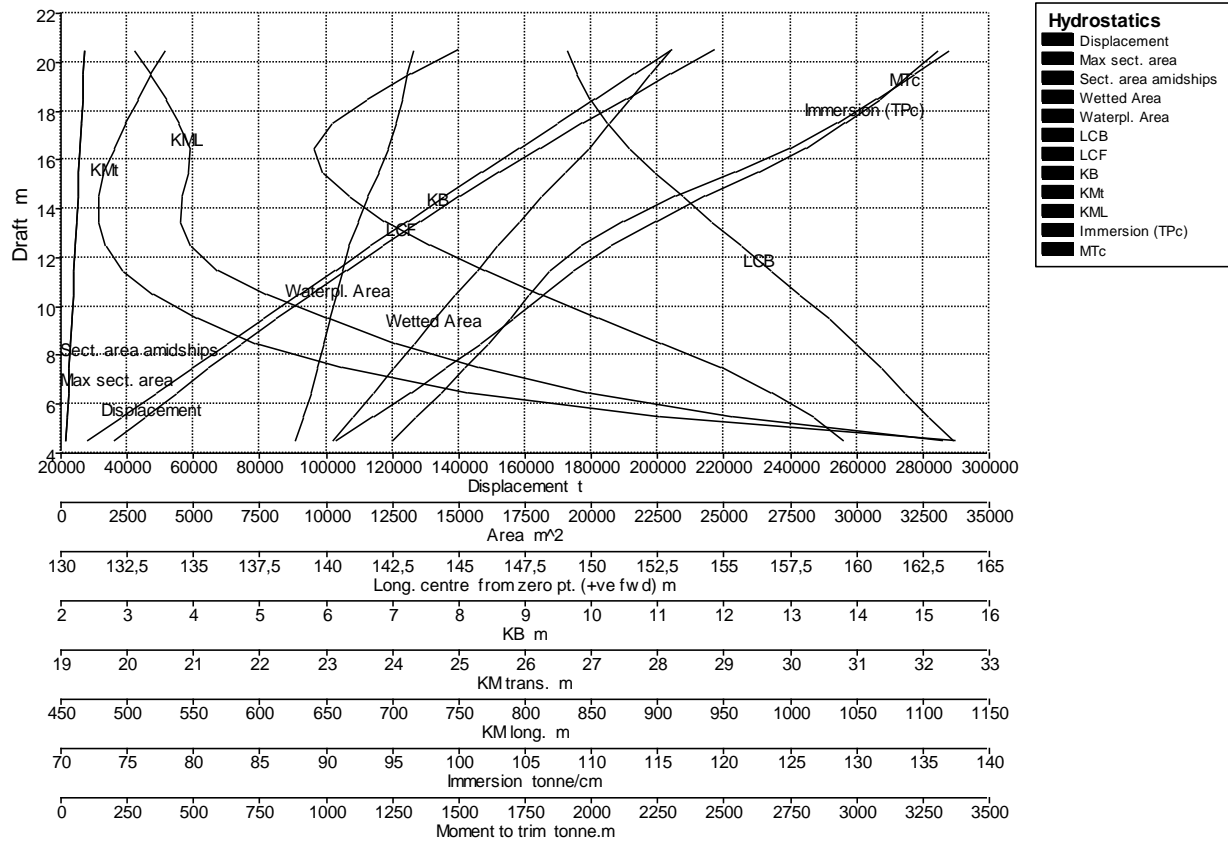

KN Calculation - formasfinalesCOMPLETAS

Stability 20.00.05.47, build: 47

Model file: D:\Desktop\mio\6º 2015-2016\PROYECTO\Cuaderno3\NUEVAS FORMAS AFIN\formasfinalesCOMPLETAS (Medium precision, 116 sections, Trimming on, Skin thickness not applied). Long. datum: AP; Vert. datum: Baseline. Analysis tolerance - ideal(worst case): Disp.%(0,01000(0,100); Trim%(LCG-TCG): 0,01000(0,100); Heel%(LCG-TCG): 0,01000(0,100)

Damage Case - Intact

Fixed Trim = 3,184 m (+ve by stern)

Specific gravity = 1,025; (Density = 1,025 tonne/m³)

VCG = 0 m; TCG = 0 m

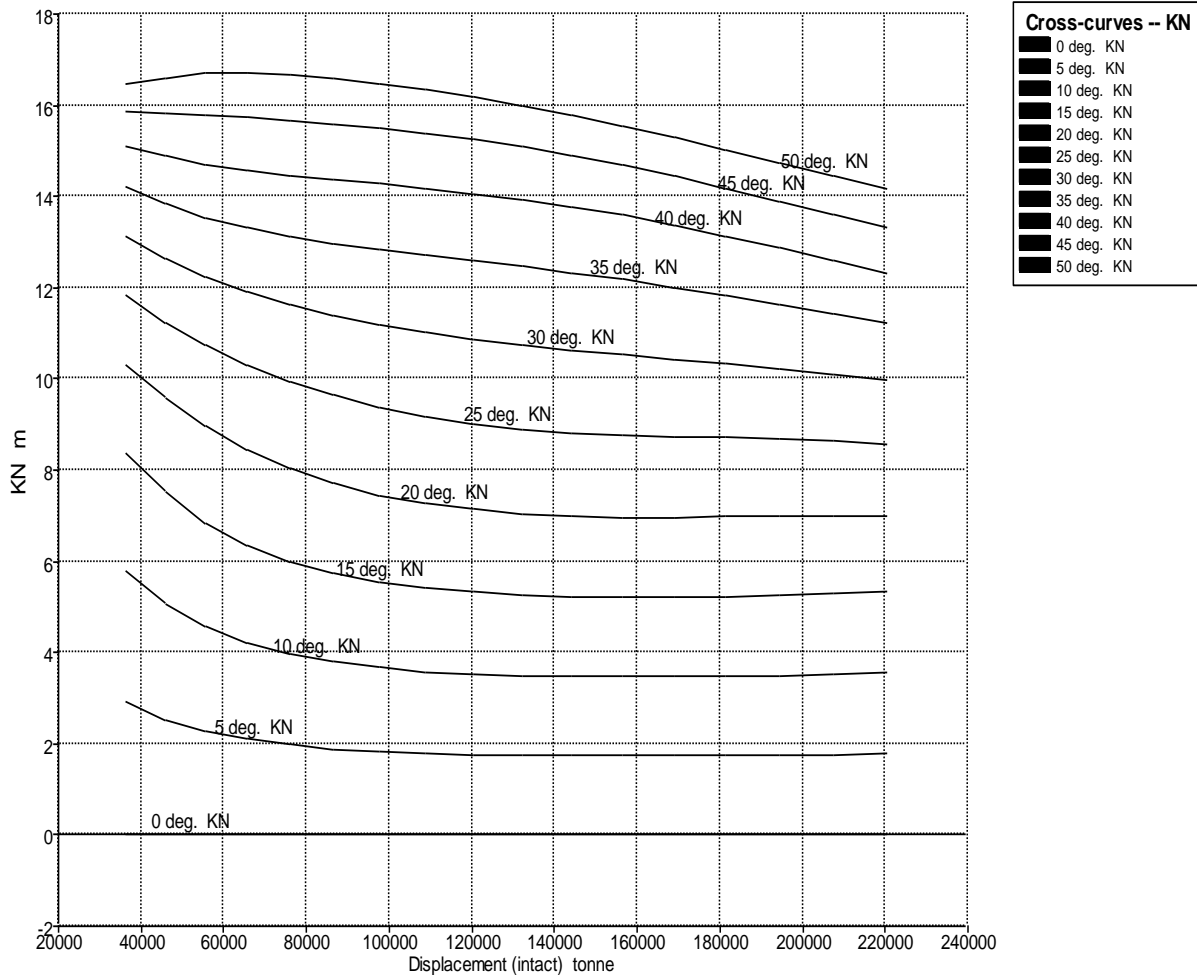

KN Calculation - formasfinalesCOMPLETAS

Stability 20.00.05.47, build: 47

Model file: D:\Desktop\mio\6º 2015-2016\PROYECTO\Cuaderno3\NUEVAS FORMAS AFIN\formasfinalesCOMPLETAS (Medium precision, 116 sections, Trimming on, Skin

thickness not applied). Long. datum: AP; Vert. datum: Baseline. Analysis tolerance - ideal(worst case): Disp. %: 0,01000(0,100); Trim%(LCG-TCG): 0,01000(0,100); Heel%(LCG-TCG): 0,01000(0,100)

Damage Case - Intact

Fixed Trim = 1,592 m (+ve by stern)

Specific gravity = 1,025; (Density = 1,025 tonne/m³)

VCG = 0 m; TCG = 0 m

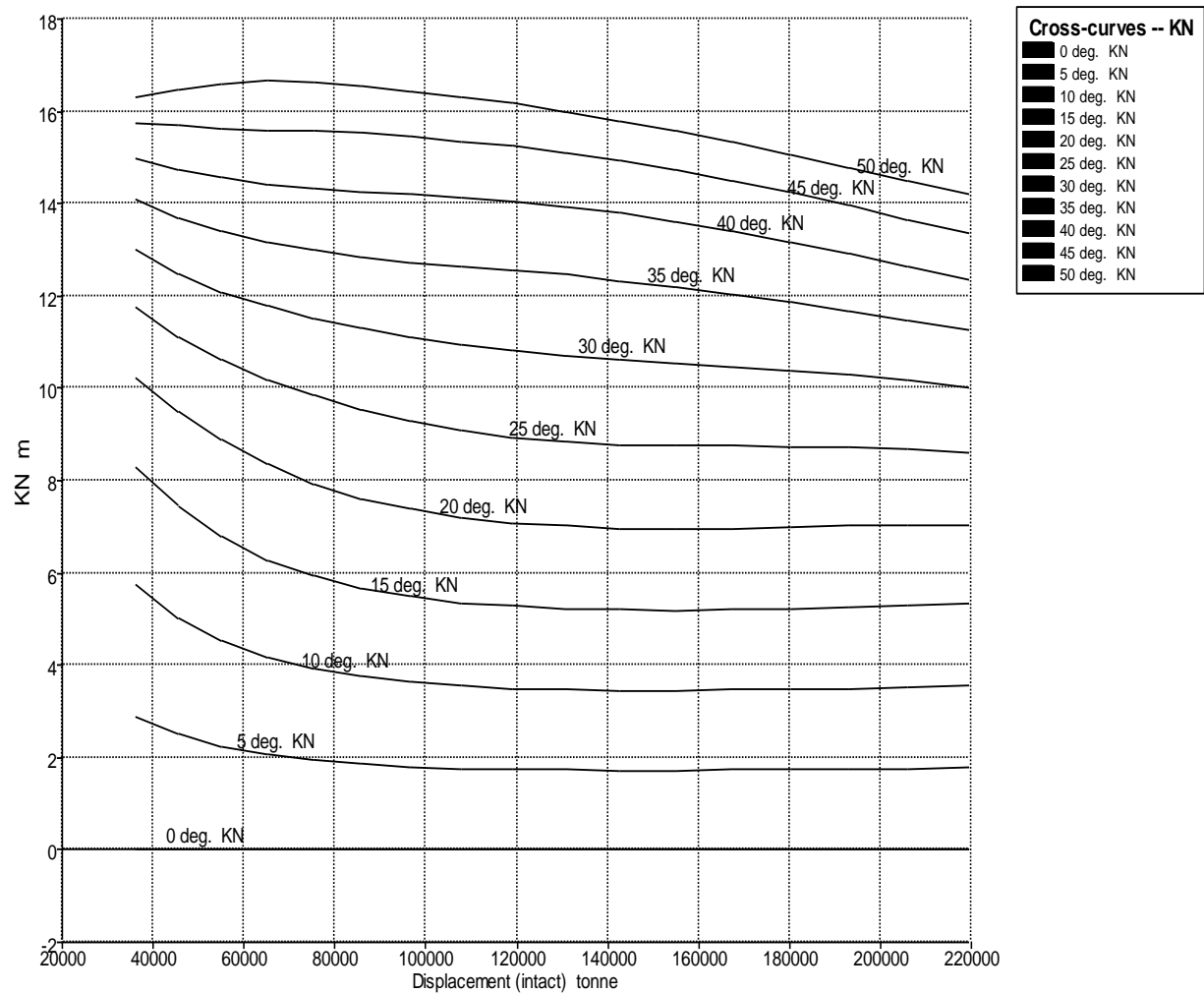

KN Calculation - formasfinalesCOMPLETAS

Stability 20.00.05.47, build: 47

Model file: D:\Desktop\mio\6º 2015-2016\PROYECTO\Cuaderno3\NUEVAS FORMAS AFIN\formasfinalesCOMPLETAS (Medium precision, 116 sections, Trimming on, Skin thickness not applied). Long. datum: AP; Vert. datum: Baseline. Analysis tolerance - ideal(worst case): Disp. %: 0,01000(0,100); Trim%(LCG-TCG): 0,01000(0,100); Heel%(LCG-TCG): 0,01000(0,100)

Damage Case - Intact

Fixed Trim = 0 m (+ve by stern)

Specific gravity = 1,025; (Density = 1,025 tonne/m³)

VCG = 0 m; TCG = 0 m

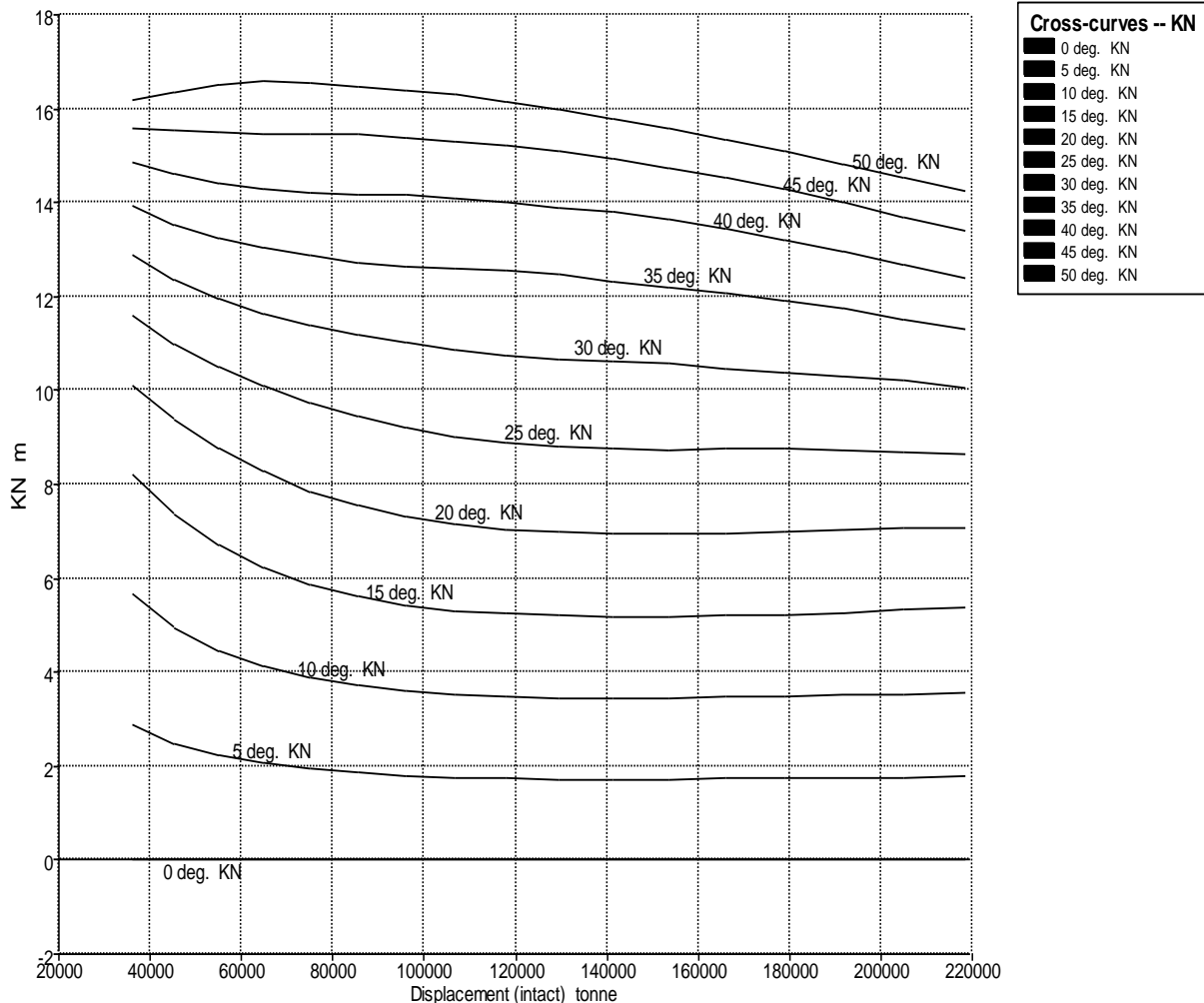

KN Calculation - formasfinalesCOMPLETAS

Stability 20.00.05.47, build: 47

Model file: D:\Desktop\mio\6° 2015-2016\PROYECTO\Cuaderno3\NUEVAS FORMAS AFIN\formasfinalesCOMPLETAS (Medium precision, 116 sections, Trimming on, Skin thickness not applied). Long. datum: AP; Vert. datum: Baseline. Analysis tolerance - ideal(worst case): Disp.%; 0,01000(0,100); Trim%(LCG-TCG): 0,01000(0,100); Heel%(LCG-TCG): 0,01000(0,100)

Damage Case - Intact

Fixed Trim = -1,592 m (+ve by stern)

Specific gravity = 1,025; (Density = 1,025 tonne/m³)

VCG = 0 m; TCG = 0 m

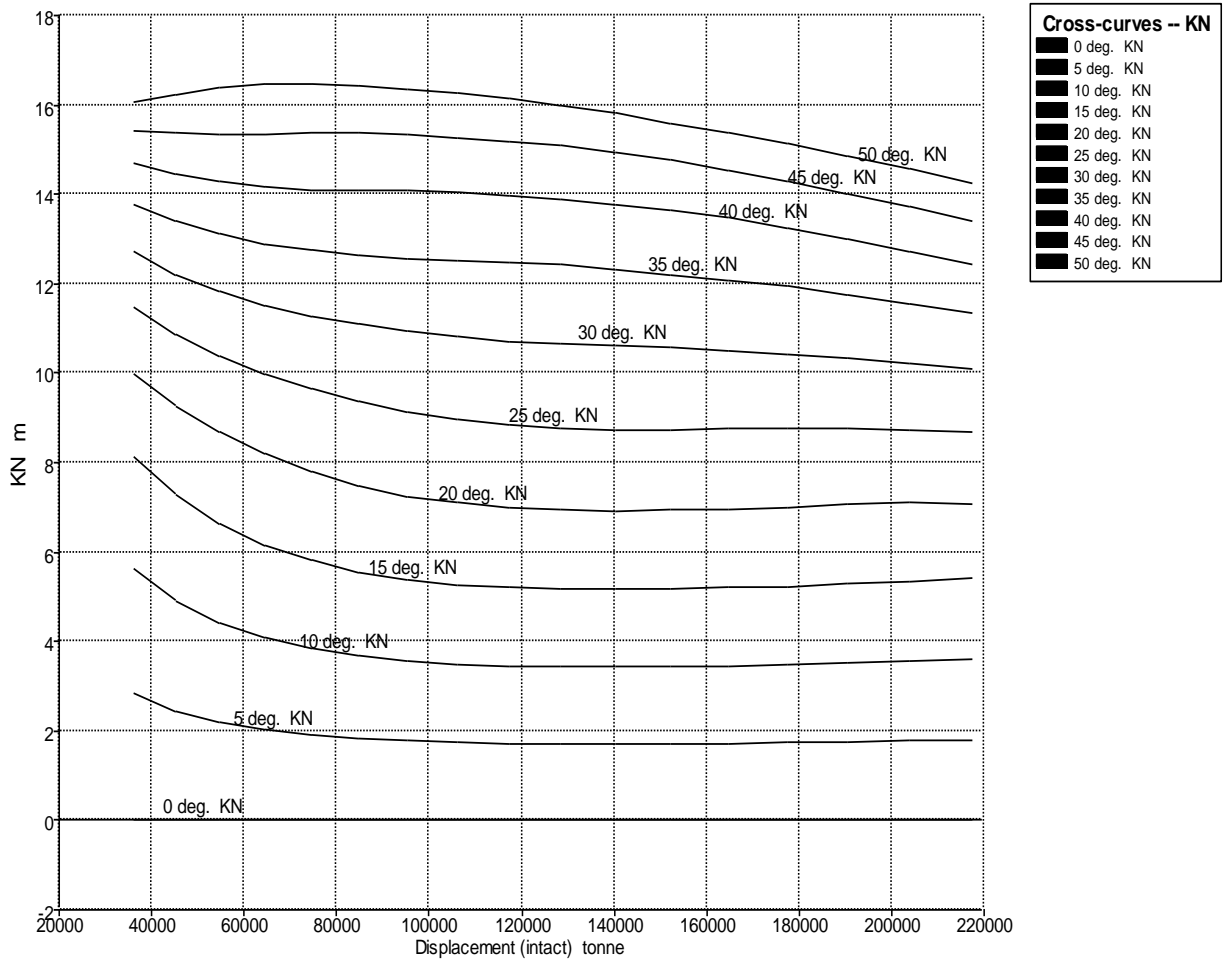

ANEXO II: RESULTADOS CALIBRACIÓN TANQUES MAXSURF

Tank Calibrations - FORMASDEFINITIVAS2!AHORASI!

Tank Calibrations - pique de popa

Fluid Type = Water Ballast Specific gravity = 1,025

Permeability = 100 %

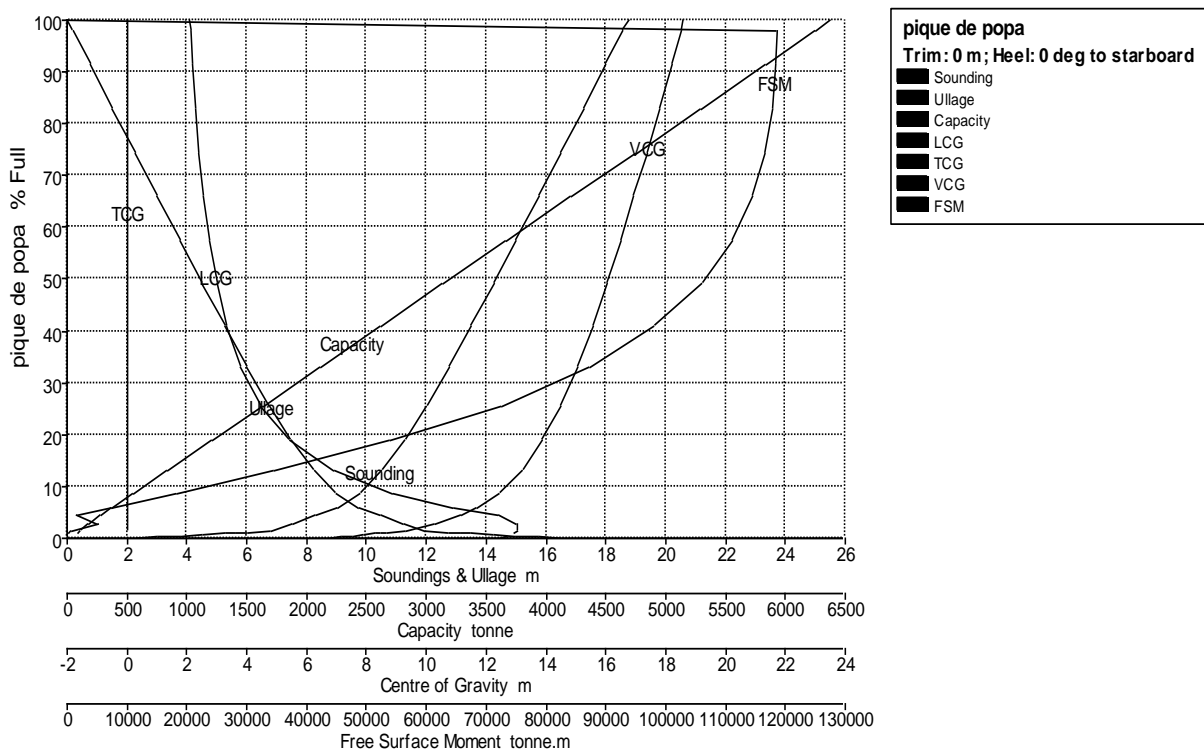

Trim = 0 m (+ve by stern); Heel = 0 deg to starboard

Tank Name	Sounding m	Ullage m	% Full	Capacity m ³	Capacity tonne	LCG m	TCG m	VCG m	FSM tonne.m
pique de popa	18,750	0,000	100,000	6219,234	6374,715	2,092	0,000	18,598	0,000
	18,575	0,175	98,000	6094,849	6247,221	2,111	0,000	18,503	118681,336
	18,566	0,184	97,900	6088,630	6240,846	2,112	0,000	18,499	118678,426
	18,000	0,750	91,430	5686,214	5828,370	2,179	0,000	18,192	118416,941

	17,250	1,500	82,868	5153,771	5282,615	2,283	0,000	17,779	117776,444
	16,500	2,250	74,329	4622,698	4738,265	2,410	0,000	17,360	116594,880
	15,750	3,000	65,830	4094,098	4196,451	2,566	0,000	16,931	114534,979
	15,000	3,750	57,398	3569,721	3658,964	2,762	0,000	16,491	111137,835
	14,250	4,500	49,078	3052,285	3128,592	3,014	0,000	16,035	105851,570
	13,500	5,250	40,934	2545,809	2609,454	3,350	0,000	15,558	98020,738
	12,750	6,000	33,061	2056,119	2107,522	3,812	0,000	15,052	87048,020
	12,000	6,750	25,599	1592,091	1631,894	4,475	0,000	14,503	72241,956
	11,250	7,500	18,779	1167,903	1197,100	5,459	0,000	13,891	53741,776
	10,500	8,250	12,919	803,471	823,558	6,941	0,000	13,187	34393,875
	9,750	9,000	8,496	528,393	541,603	8,906	0,000	12,398	18132,300
	9,000	9,750	5,725	356,040	364,941	10,919	0,000	11,639	7121,331
	8,250	10,500	4,330	269,279	276,011	12,426	0,000	11,125	1464,192
	7,500	11,250	2,590	161,053	165,079	13,061	0,000	10,276	5062,155
	6,750	12,000	1,527	94,970	97,345	13,060	0,000	9,255	615,126
	6,000	12,750	1,136	70,655	72,421	12,870	0,000	8,662	47,377
	5,585	13,165	1,000	62,193	63,748	12,813	0,000	8,432	22,197
	5,250	13,500	0,901	56,019	57,419	12,782	0,000	8,261	16,730
	4,500	14,250	0,685	42,601	43,666	12,735	0,000	7,893	14,319
	3,750	15,000	0,466	29,001	29,727	12,705	0,000	7,525	14,632
	3,000	15,750	0,242	15,064	15,440	12,684	0,000	7,151	15,294
	2,250	16,500	0,015	0,927	0,950	12,406	0,000	6,712	15,526
	1,500	17,250	0,001	0,040	0,041	9,106	0,000	5,486	0,000
	0,750	18,000	0,000	0,013	0,014	9,106	0,000	5,026	0,000
	0,000	18,750	0,000	0,000	0,000	9,106	0,000	4,555	0,000

Tank Calibrations - agua tecnica bab

Fluid Type = Fresh Water Specific gravity = 1

Permeability = 100 %

Trim = 0 m (+ve by stern); Heel = 0 deg to starboard

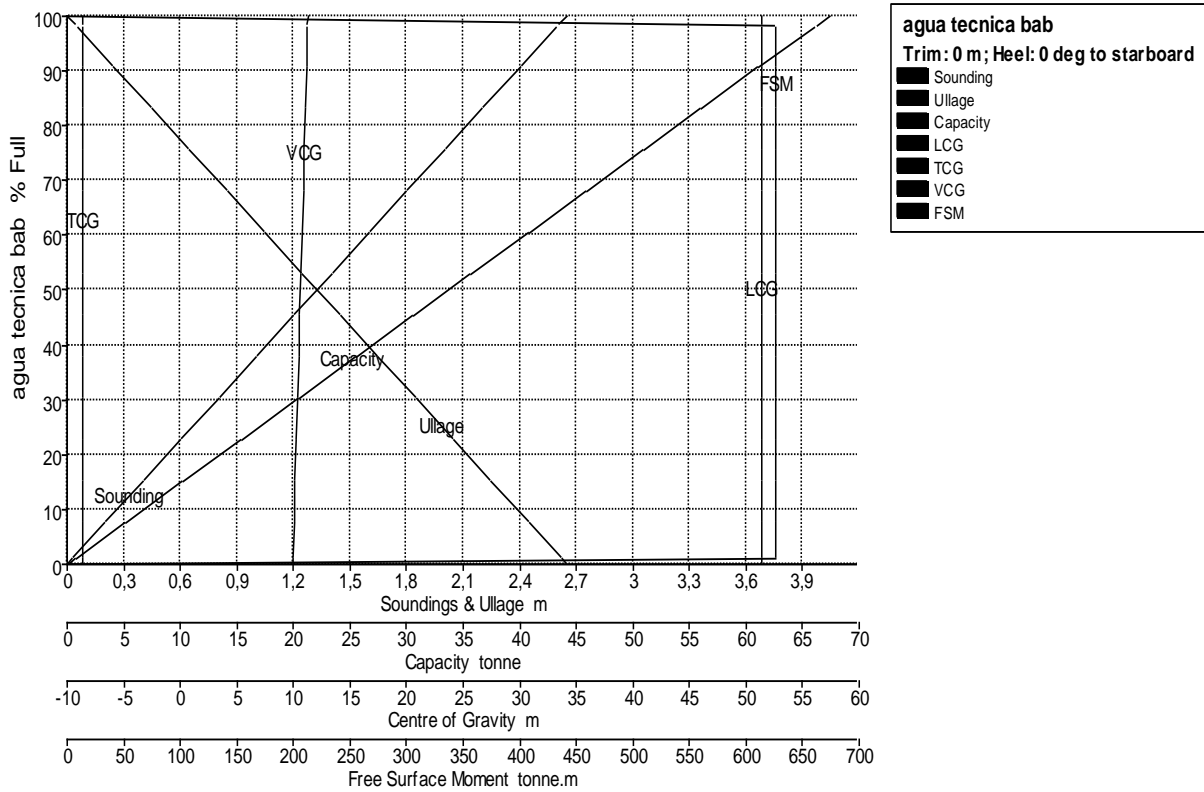

Tank Name	Sounding m	Ullage m	% Full	Capacity m ³	Capacity tonne	LCG m	TCG m	VCG m	FSM tonne.m
agua tecnica bab	2,650	0,000	100,000	67,400	67,400	51,377	-8,592	11,275	0,000
	2,600	0,050	98,113	66,128	66,128	51,377	-8,592	11,250	625,935
	2,597	0,053	98,000	66,052	66,052	51,377	-8,592	11,249	625,935
	2,594	0,056	97,900	65,984	65,984	51,377	-8,592	11,247	625,935
	2,400	0,250	90,566	61,041	61,041	51,377	-8,592	11,150	625,935
	2,200	0,450	83,019	55,954	55,954	51,377	-8,592	11,050	625,935
	2,000	0,650	75,472	50,868	50,868	51,377	-8,592	10,950	625,935
	1,800	0,850	67,925	45,781	45,781	51,377	-8,592	10,850	625,935
	1,600	1,050	60,377	40,694	40,694	51,377	-8,592	10,750	625,935
	1,400	1,250	52,830	35,607	35,607	51,377	-8,592	10,650	625,935
	1,200	1,450	45,283	30,521	30,521	51,377	-8,592	10,550	625,935
	1,000	1,650	37,736	25,434	25,434	51,377	-8,592	10,450	625,935
	0,800	1,850	30,189	20,347	20,347	51,377	-8,592	10,350	625,935
	0,600	2,050	22,642	15,260	15,260	51,377	-8,592	10,250	625,935

	0,400	2,250	15,094	10,174	10,174	51,377	-8,592	10,150	625,935
	0,200	2,450	7,547	5,087	5,087	51,377	-8,592	10,050	625,935
	0,027	2,624	1,000	0,674	0,674	51,377	-8,592	9,963	625,935
	0,000	2,650	0,000	0,000	0,000	51,377	-8,592	9,950	0,000

Tank Calibrations - agua potable bab

Fluid Type = Fresh Water Specific gravity = 1

Permeability = 100 %

rim = 0 m (+ve by stern); Heel = 0 deg to starboard

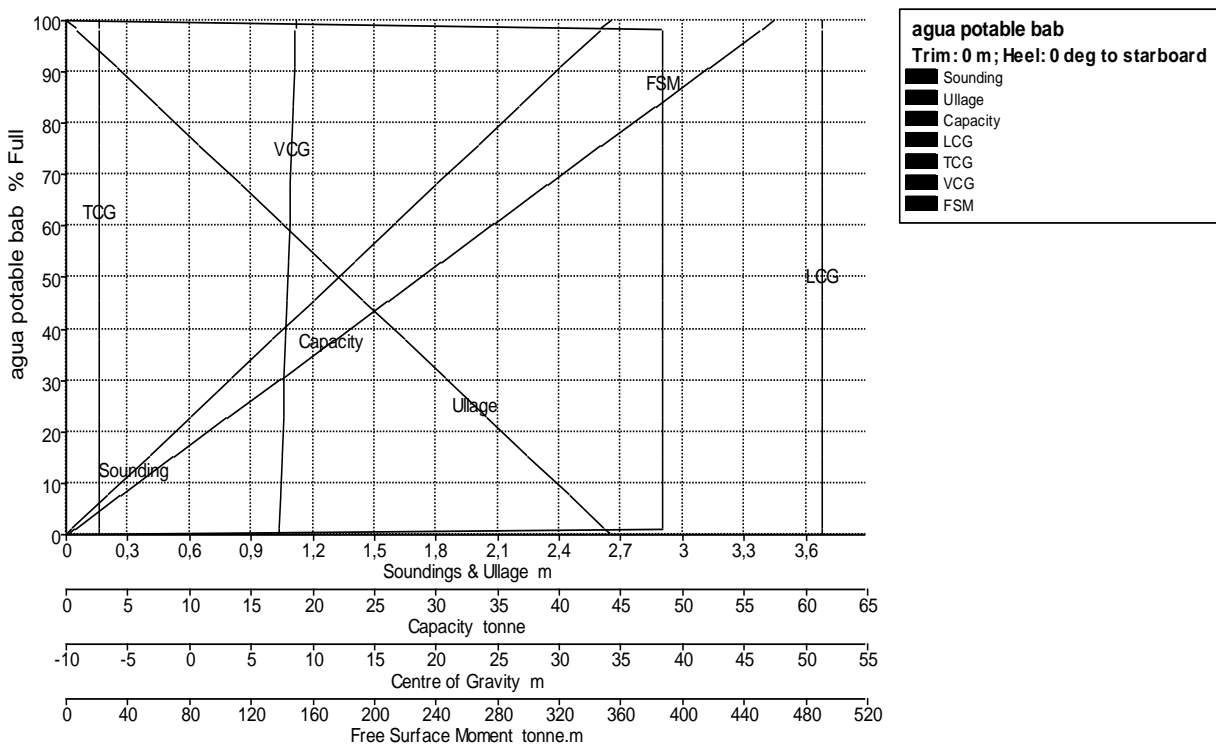

Tank Name	Sounding m	Ullage m	% Full	Capacity m ³	Capacity tonne	LCG m	TCG m	VCG m	FSM tonne.m
agua potable bab	2,650	0,000	100,000	57,438	57,438	51,377	-7,323	8,625	0,000
	2,600	0,050	98,113	56,354	56,354	51,377	-7,323	8,600	387,390
	2,597	0,053	98,000	56,289	56,289	51,377	-7,323	8,599	387,390
	2,594	0,056	97,900	56,231	56,231	51,377	-7,323	8,597	387,390
	2,400	0,250	90,566	52,019	52,019	51,377	-7,323	8,500	387,390
	2,200	0,450	83,019	47,684	47,684	51,377	-7,323	8,400	387,390

	2,000	0,650	75,472	43,349	43,349	51,377	-7,323	8,300	387,390
	1,800	0,850	67,925	39,014	39,014	51,377	-7,323	8,200	387,390
	1,600	1,050	60,377	34,679	34,679	51,377	-7,323	8,100	387,390
	1,400	1,250	52,830	30,344	30,344	51,377	-7,323	8,000	387,390
	1,200	1,450	45,283	26,010	26,010	51,377	-7,323	7,900	387,390
	1,000	1,650	37,736	21,675	21,675	51,377	-7,323	7,800	387,390
	0,800	1,850	30,189	17,340	17,340	51,377	-7,323	7,700	387,390
	0,600	2,050	22,642	13,005	13,005	51,377	-7,323	7,600	387,390
	0,400	2,250	15,094	8,670	8,670	51,377	-7,323	7,500	387,390
	0,200	2,450	7,547	4,335	4,335	51,377	-7,323	7,400	387,390
	0,026	2,623	1,000	0,574	0,574	51,377	-7,323	7,313	387,390
	0,000	2,650	0,000	0,000	0,000	51,377	-7,323	7,300	0,000

Tank Calibrations - agua tecnica estrib

Fluid Type = Fresh Water Specific gravity = 1

Permeability = 100 %

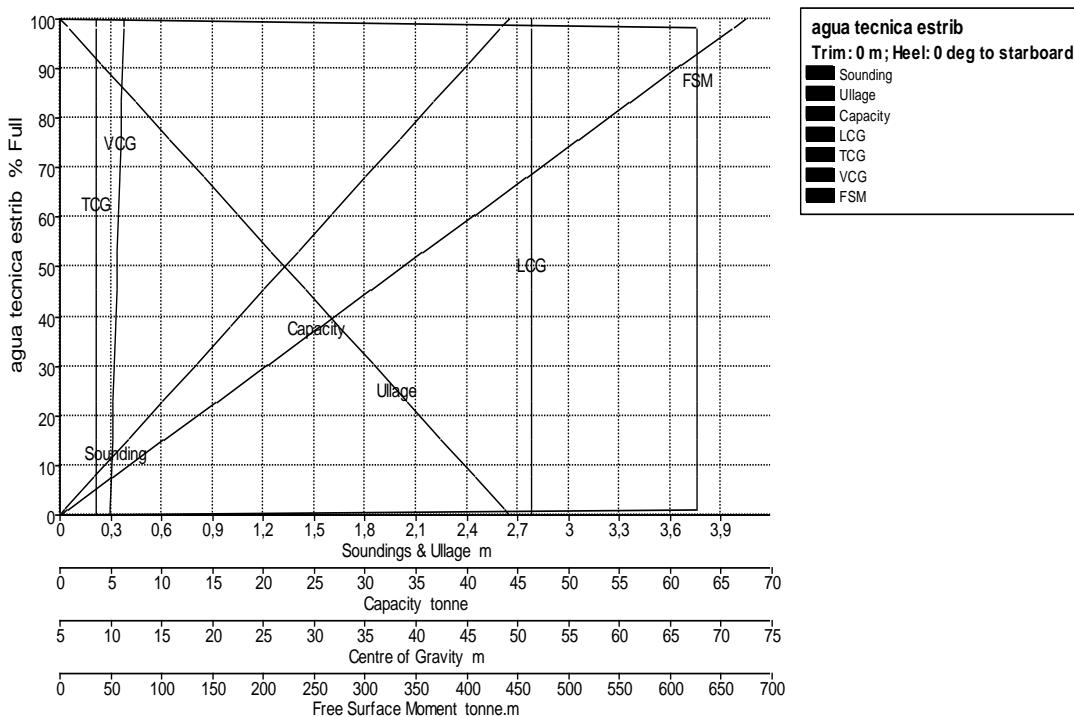

Trim = 0 m (+ve by stern); Heel = 0 deg to starboard

Tank Name	Sounding m	Ullage m	% Full	Capacity m ³	Capacity tonne	LCG m	TCG m	VCG m	FSM tonne.m
agua tecnica estrib	2,650	0,000	100,000	67,400	67,400	51,377	8,592	11,275	0,000
	2,600	0,050	98,113	66,128	66,128	51,377	8,592	11,250	625,935
	2,597	0,053	98,000	66,052	66,052	51,377	8,592	11,249	625,935
	2,594	0,056	97,900	65,984	65,984	51,377	8,592	11,247	625,935
	2,400	0,250	90,566	61,041	61,041	51,377	8,592	11,150	625,935
	2,200	0,450	83,019	55,954	55,954	51,377	8,592	11,050	625,935
	2,000	0,650	75,472	50,868	50,868	51,377	8,592	10,950	625,935
	1,800	0,850	67,925	45,781	45,781	51,377	8,592	10,850	625,935
	1,600	1,050	60,377	40,694	40,694	51,377	8,592	10,750	625,935
	1,400	1,250	52,830	35,607	35,607	51,377	8,592	10,650	625,935
	1,200	1,450	45,283	30,521	30,521	51,377	8,592	10,550	625,935
	1,000	1,650	37,736	25,434	25,434	51,377	8,592	10,450	625,935
	0,800	1,850	30,189	20,347	20,347	51,377	8,592	10,350	625,935
	0,600	2,050	22,642	15,260	15,260	51,377	8,592	10,250	625,935
	0,400	2,250	15,094	10,174	10,174	51,377	8,592	10,150	625,935
	0,200	2,450	7,547	5,087	5,087	51,377	8,592	10,050	625,935
	0,027	2,624	1,000	0,674	0,674	51,377	8,592	9,963	625,935
	0,000	2,650	0,000	0,000	0,000	51,377	8,592	9,950	0,000

Tank Calibrations - agua potable estrib

Fluid Type = Fresh Water Specific gravity = 1

Permeability = 100 %

Trim = 0 m (+ve by stern); Heel = 0 deg to starboard

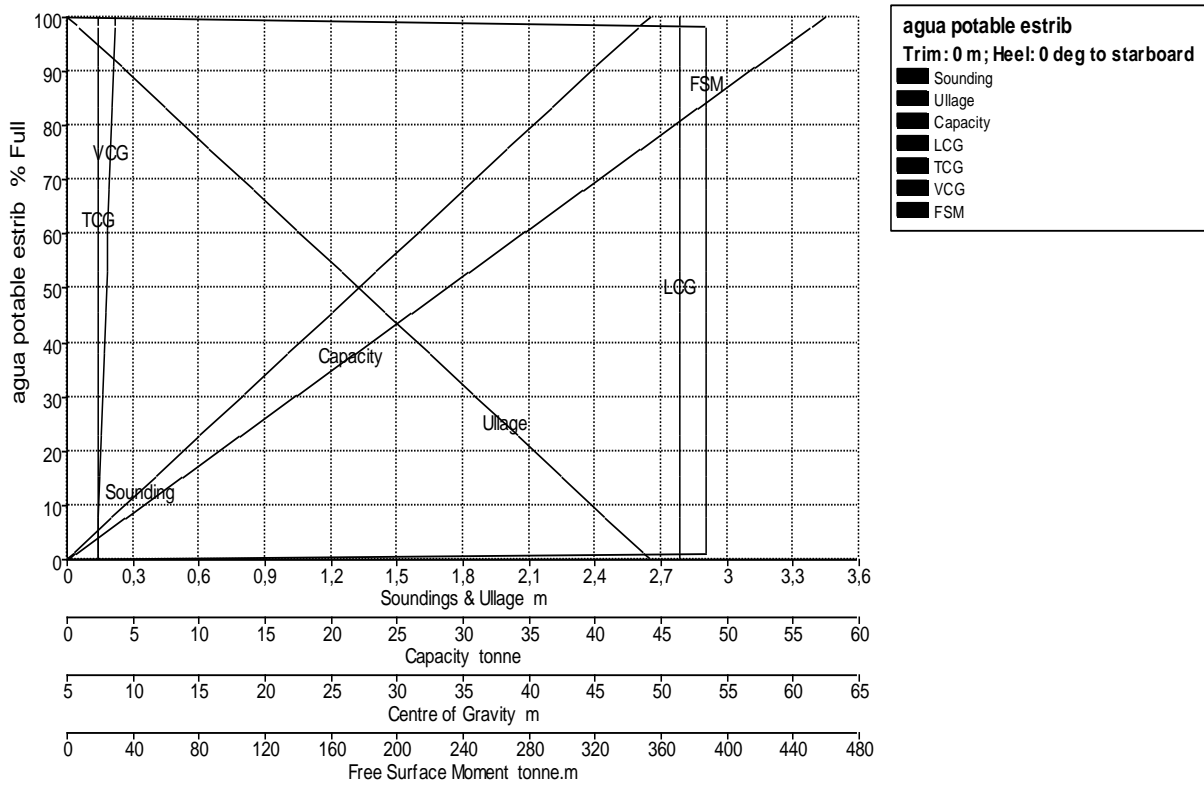

Tank Name	Sounding m	Ullage m	% Full	Capacity m ³	Capacity tonne	LCG m	TCG m	VCG m	FSM tonne.m
agua potable estrib	2,650	0,000	100,000	57,438	57,438	51,377	7,323	8,625	0,000
	2,600	0,050	98,113	56,354	56,354	51,377	7,323	8,600	387,390
	2,597	0,053	98,000	56,289	56,289	51,377	7,323	8,599	387,390
	2,594	0,056	97,900	56,231	56,231	51,377	7,323	8,597	387,390
	2,400	0,250	90,566	52,019	52,019	51,377	7,323	8,500	387,390
	2,200	0,450	83,019	47,684	47,684	51,377	7,323	8,400	387,390
	2,000	0,650	75,472	43,349	43,349	51,377	7,323	8,300	387,390
	1,800	0,850	67,925	39,014	39,014	51,377	7,323	8,200	387,390
	1,600	1,050	60,377	34,679	34,679	51,377	7,323	8,100	387,390
	1,400	1,250	52,830	30,344	30,344	51,377	7,323	8,000	387,390
	1,200	1,450	45,283	26,010	26,010	51,377	7,323	7,900	387,390

	1,000	1,650	37,736	21,675	21,675	51,377	7,323	7,800	387,390
	0,800	1,850	30,189	17,340	17,340	51,377	7,323	7,700	387,390
	0,600	2,050	22,642	13,005	13,005	51,377	7,323	7,600	387,390
	0,400	2,250	15,094	8,670	8,670	51,377	7,323	7,500	387,390
	0,200	2,450	7,547	4,335	4,335	51,377	7,323	7,400	387,390
	0,026	2,623	1,000	0,574	0,574	51,377	7,323	7,313	387,390
	0,000	2,650	0,000	0,000	0,000	51,377	7,323	7,300	0,000

Tank Calibrations - fuel uso diario bab

Fluid Type = Fuel Oil Specific gravity = 0,9443

Permeability = 100 %

Trim = 0 m (+ve by stern); Heel = 0 deg to starboard

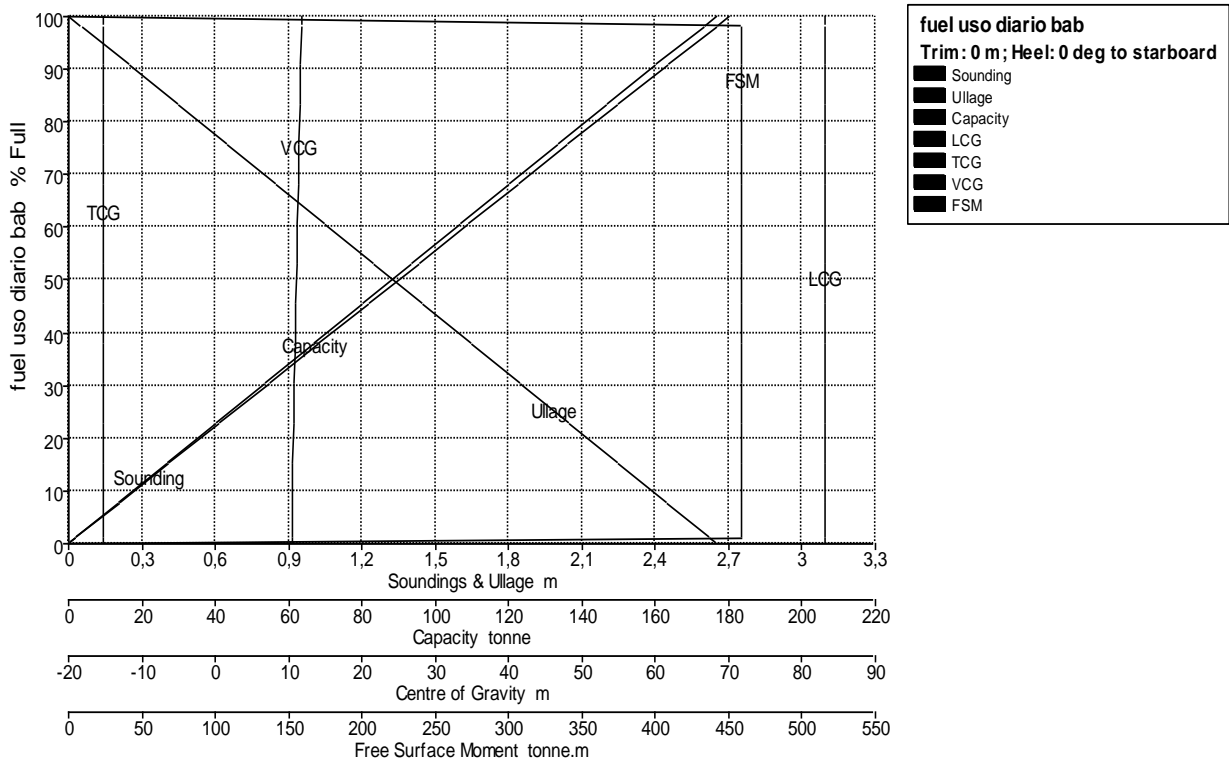

Tank Name	Sounding m	Ullage m	% Full	Capacity m ³	Capacity tonne	LCG m	TCG m	VCG m	FSM tonne.m
fuel uso diario bab	2,650	0,000	100,000	190,800	180,172	83,180	-15,225	11,735	0,000
	2,600	0,050	98,113	187,200	176,773	83,180	-15,225	11,710	458,930
	2,597	0,053	98,000	186,984	176,569	83,180	-15,225	11,709	458,930
	2,594	0,056	97,900	186,793	176,389	83,180	-15,225	11,707	458,930
	2,400	0,250	90,566	172,800	163,175	83,180	-15,225	11,610	458,930
	2,200	0,450	83,019	158,400	149,577	83,180	-15,225	11,510	458,930
	2,000	0,650	75,472	144,000	135,979	83,180	-15,225	11,410	458,930
	1,800	0,850	67,925	129,600	122,381	83,180	-15,225	11,310	458,930
	1,600	1,050	60,377	115,200	108,783	83,180	-15,225	11,210	458,930
	1,400	1,250	52,830	100,800	95,185	83,180	-15,225	11,110	458,930
	1,200	1,450	45,283	86,400	81,588	83,180	-15,225	11,010	458,930
	1,000	1,650	37,736	72,000	67,990	83,180	-15,225	10,910	458,930
	0,800	1,850	30,189	57,600	54,392	83,180	-15,225	10,810	458,930
	0,600	2,050	22,642	43,200	40,794	83,180	-15,225	10,710	458,930
	0,400	2,250	15,094	28,800	27,196	83,180	-15,225	10,610	458,930
	0,200	2,450	7,547	14,400	13,598	83,180	-15,225	10,510	458,930
	0,027	2,624	1,000	1,908	1,802	83,180	-15,225	10,423	458,930
	0,000	2,650	0,000	0,000	0,000	83,180	-15,225	10,410	0,000

Tank Calibrations - fuel uso diario estrib

Fluid Type = Fuel Oil Specific gravity = 0,9443

Permeability = 100 %

Trim = 0 m (+ve by stern); Heel = 0 deg to starboard

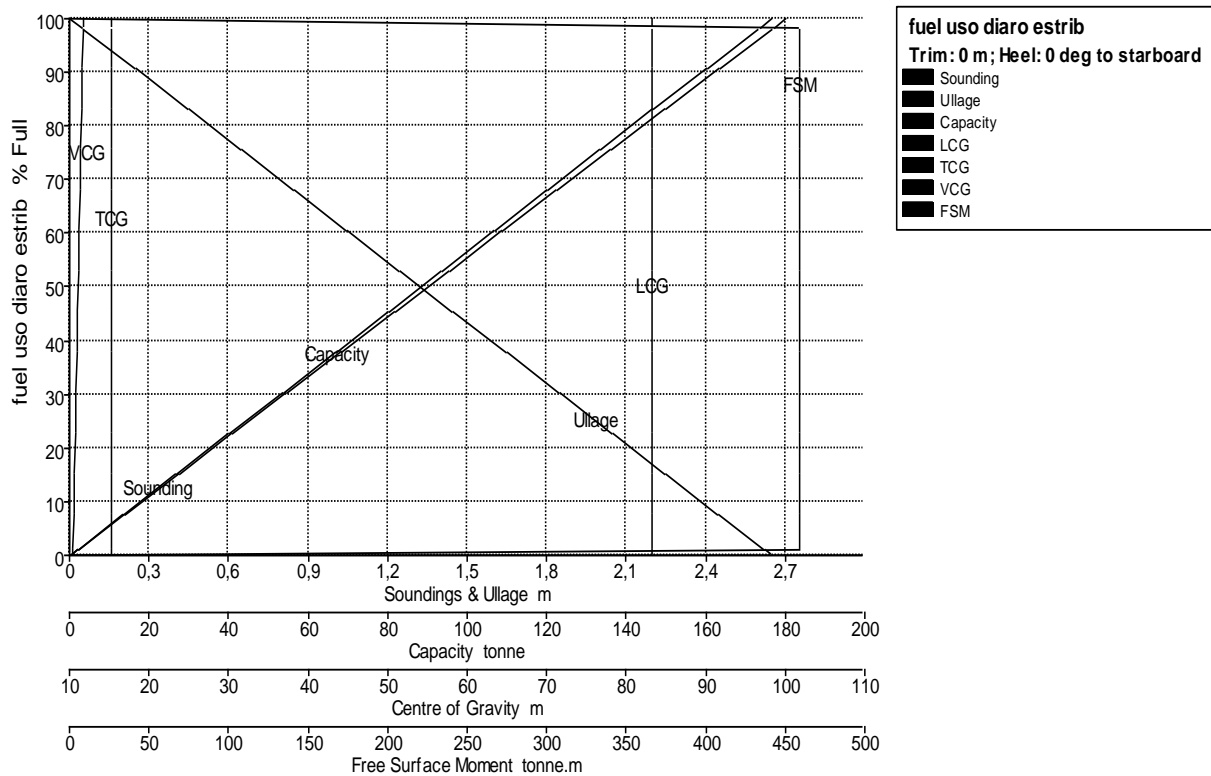

Tank Name	Sounding m	Ullage m	% Full	Capacity m ³	Capacity tonne	LCG m	TCG m	VCG m	FSM tonne.m
fuel uso diaro estrib	2,650	0,000	100,000	190,800	180,172	83,180	15,225	11,735	0,000
	2,600	0,050	98,113	187,200	176,773	83,180	15,225	11,710	458,930
	2,597	0,053	98,000	186,984	176,569	83,180	15,225	11,709	458,930
	2,594	0,056	97,900	186,793	176,389	83,180	15,225	11,707	458,930
	2,400	0,250	90,566	172,800	163,175	83,180	15,225	11,610	458,930
	2,200	0,450	83,019	158,400	149,577	83,180	15,225	11,510	458,930
	2,000	0,650	75,472	144,000	135,979	83,180	15,225	11,410	458,930
	1,800	0,850	67,925	129,600	122,381	83,180	15,225	11,310	458,930
	1,600	1,050	60,377	115,200	108,783	83,180	15,225	11,210	458,930
	1,400	1,250	52,830	100,800	95,185	83,180	15,225	11,110	458,930
	1,200	1,450	45,283	86,400	81,588	83,180	15,225	11,010	458,930
	1,000	1,650	37,736	72,000	67,990	83,180	15,225	10,910	458,930
	0,800	1,850	30,189	57,600	54,392	83,180	15,225	10,810	458,930
	0,600	2,050	22,642	43,200	40,794	83,180	15,225	10,710	458,930
	0,400	2,250	15,094	28,800	27,196	83,180	15,225	10,610	458,930

	0,200	2,450	7,547	14,400	13,598	83,180	15,225	10,510	458,930
	0,027	2,624	1,000	1,908	1,802	83,180	15,225	10,423	458,930
	0,000	2,650	0,000	0,000	0,000	83,180	15,225	10,410	0,000

Tank Calibrations - fuel sedimentacion bab

Fluid Type = Fuel Oil Specific gravity = 0,9443

Permeability = 100 %

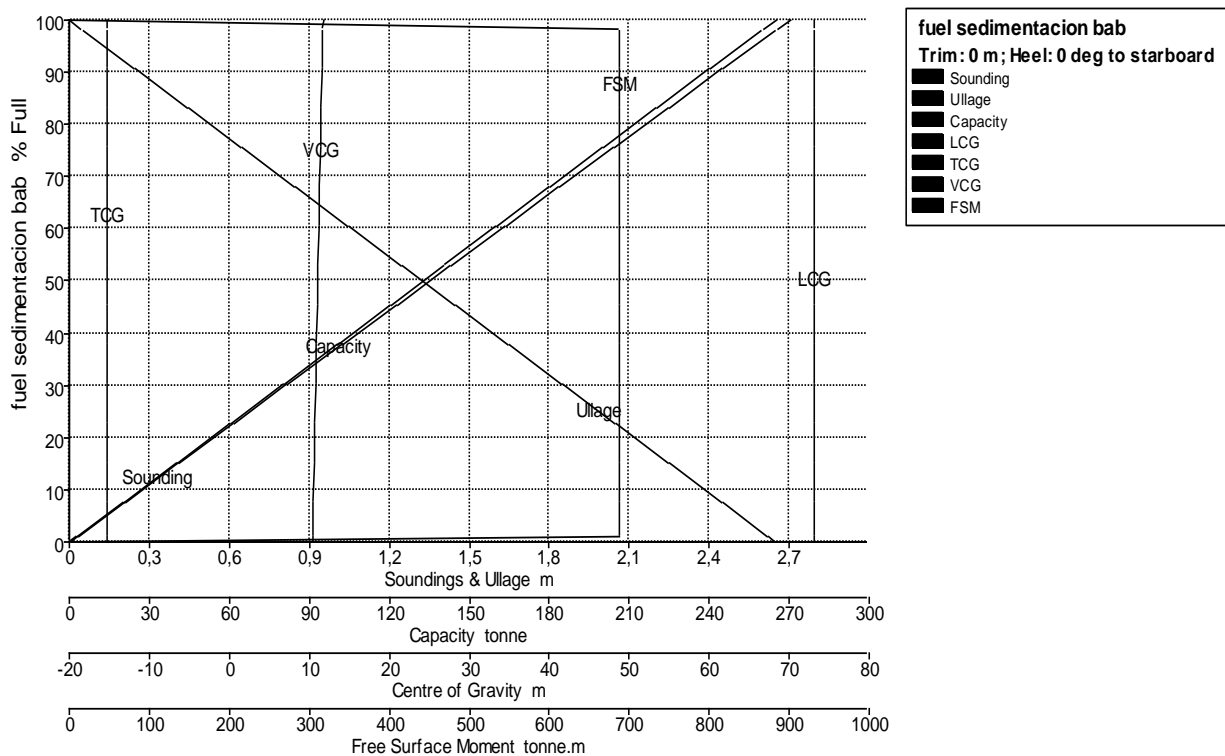

Trim = 0 m (+ve by stern); Heel = 0 deg to starboard

Tank Name	Sounding m	Ullage m	% Full	Capacity m ³	Capacity tonne	LCG m	TCG m	VCG m	FSM tonne.m
fuel sedimentacion bab	2,650	0,000	100,000	286,200	270,259	73,180	-15,225	11,735	0,000
	2,600	0,050	98,113	280,800	265,159	73,180	-15,225	11,710	688,395
	2,597	0,053	98,000	280,476	264,854	73,180	-15,225	11,709	688,395
	2,594	0,056	97,900	280,190	264,583	73,180	-15,225	11,707	688,395
	2,400	0,250	90,566	259,200	244,763	73,180	-15,225	11,610	688,395

	2,200	0,450	83,019	237,600	224,366	73,180	-15,225	11,510	688,395
	2,000	0,650	75,472	216,000	203,969	73,180	-15,225	11,410	688,395
	1,800	0,850	67,925	194,400	183,572	73,180	-15,225	11,310	688,395
	1,600	1,050	60,377	172,800	163,175	73,180	-15,225	11,210	688,395
	1,400	1,250	52,830	151,200	142,778	73,180	-15,225	11,110	688,395
	1,200	1,450	45,283	129,600	122,381	73,180	-15,225	11,010	688,395
	1,000	1,650	37,736	108,000	101,984	73,180	-15,225	10,910	688,395
	0,800	1,850	30,189	86,400	81,588	73,180	-15,225	10,810	688,395
	0,600	2,050	22,642	64,800	61,191	73,180	-15,225	10,710	688,395
	0,400	2,250	15,094	43,200	40,794	73,180	-15,225	10,610	688,395
	0,200	2,450	7,547	21,600	20,397	73,180	-15,225	10,510	688,395
	0,027	2,624	1,000	2,862	2,703	73,180	-15,225	10,423	688,395
	0,000	2,650	0,000	0,000	0,000	73,180	-15,225	10,410	0,000

Tank Calibrations - fuel sedimentacion estrib

Fluid Type = Fuel Oil Specific gravity = 0,9443

Permeability = 100 %

Trim = 0 m (+ve by stern); Heel = 0 deg to starboard

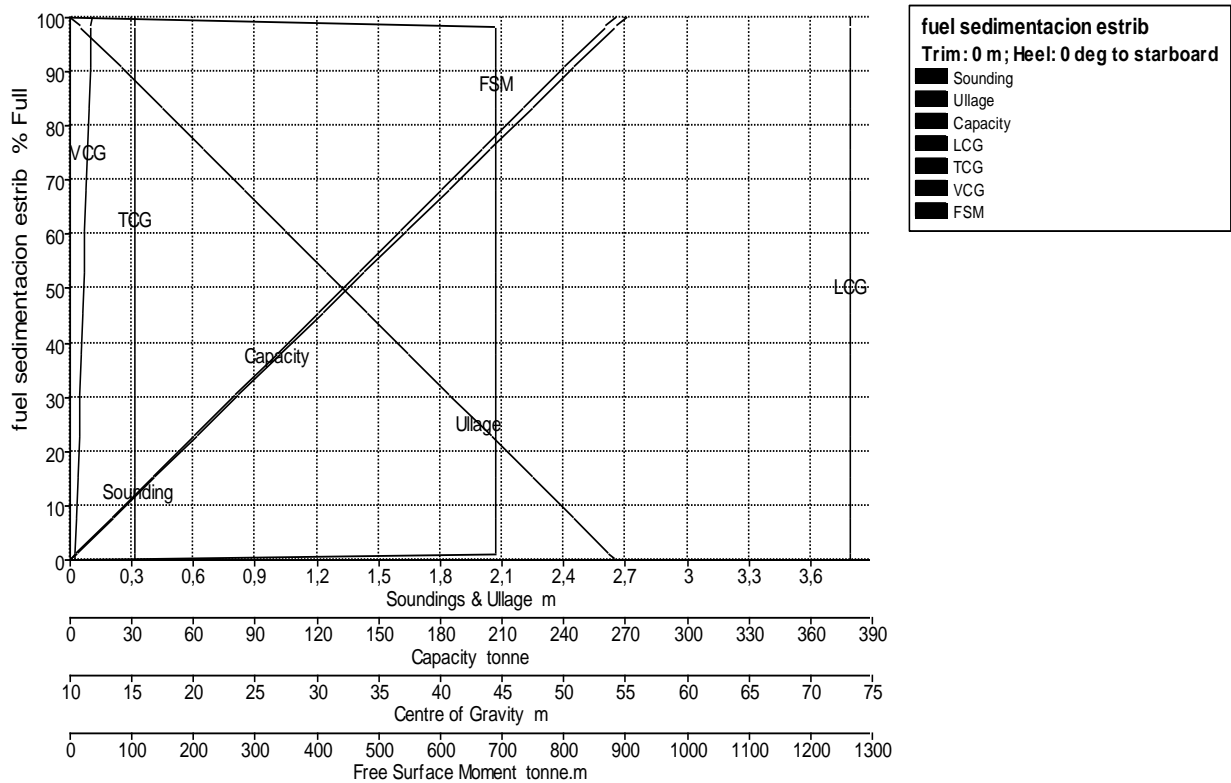

Tank Name	Sounding m	Ullage m	% Full	Capacity m ³	Capacity tonne	LCG m	TCG m	VCG m	FSM tonne.m
fuel sedimentacion estrib	2,650	0,000	100,000	286,200	270,259	73,180	15,225	11,735	0,000
	2,600	0,050	98,113	280,800	265,159	73,180	15,225	11,710	688,395
	2,597	0,053	98,000	280,476	264,854	73,180	15,225	11,709	688,395
	2,594	0,056	97,900	280,190	264,583	73,180	15,225	11,707	688,395
	2,400	0,250	90,566	259,200	244,763	73,180	15,225	11,610	688,395
	2,200	0,450	83,019	237,600	224,366	73,180	15,225	11,510	688,395
	2,000	0,650	75,472	216,000	203,969	73,180	15,225	11,410	688,395
	1,800	0,850	67,925	194,400	183,572	73,180	15,225	11,310	688,395
	1,600	1,050	60,377	172,800	163,175	73,180	15,225	11,210	688,395
	1,400	1,250	52,830	151,200	142,778	73,180	15,225	11,110	688,395
	1,200	1,450	45,283	129,600	122,381	73,180	15,225	11,010	688,395
	1,000	1,650	37,736	108,000	101,984	73,180	15,225	10,910	688,395
	0,800	1,850	30,189	86,400	81,588	73,180	15,225	10,810	688,395
	0,600	2,050	22,642	64,800	61,191	73,180	15,225	10,710	688,395
	0,400	2,250	15,094	43,200	40,794	73,180	15,225	10,610	688,395
	0,200	2,450	7,547	21,600	20,397	73,180	15,225	10,510	688,395
	0,027	2,624	1,000	2,862	2,703	73,180	15,225	10,423	688,395
	0,000	2,650	0,000	0,000	0,000	73,180	15,225	10,410	0,000

Tank Calibrations - diesel uso diario bab

Fluid Type = Fuel Oil Specific gravity = 0,9443

Permeability = 100 %

Trim = 0 m (+ve by stern); Heel = 0 deg to starboard

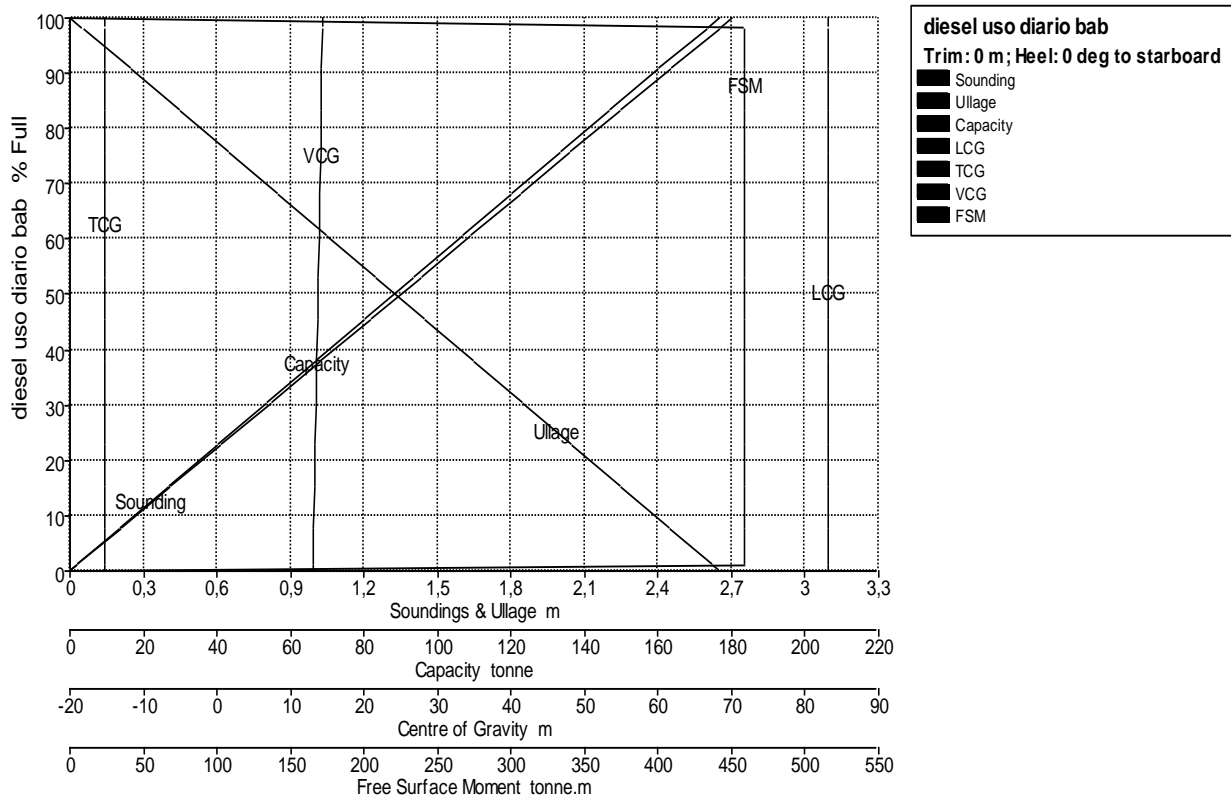

Tank Name	Sounding m	Ullage m	% Full	Capacity m ³	Capacity tonne	LCG m	TCG m	VCG m	FSM tonne.m
diesel uso diario bab	2,650	0,000	100,000	190,800	180,172	83,180	-15,225	14,385	0,000
	2,600	0,050	98,113	187,200	176,773	83,180	-15,225	14,360	458,930
	2,597	0,053	98,000	186,984	176,569	83,180	-15,225	14,359	458,930
	2,594	0,056	97,900	186,793	176,389	83,180	-15,225	14,357	458,930
	2,400	0,250	90,566	172,800	163,175	83,180	-15,225	14,260	458,930
	2,200	0,450	83,019	158,400	149,577	83,180	-15,225	14,160	458,930
	2,000	0,650	75,472	144,000	135,979	83,180	-15,225	14,060	458,930
	1,800	0,850	67,925	129,600	122,381	83,180	-15,225	13,960	458,930
	1,600	1,050	60,377	115,200	108,783	83,180	-15,225	13,860	458,930
	1,400	1,250	52,830	100,800	95,185	83,180	-15,225	13,760	458,930
	1,200	1,450	45,283	86,400	81,588	83,180	-15,225	13,660	458,930
	1,000	1,650	37,736	72,000	67,990	83,180	-15,225	13,560	458,930
	0,800	1,850	30,189	57,600	54,392	83,180	-15,225	13,460	458,930
	0,600	2,050	22,642	43,200	40,794	83,180	-15,225	13,360	458,930

	0,400	2,250	15,094	28,800	27,196	83,180	-15,225	13,260	458,930
	0,200	2,450	7,547	14,400	13,598	83,180	-15,225	13,160	458,930
	0,026	2,623	1,000	1,908	1,802	83,180	-15,225	13,073	458,930
	0,000	2,650	0,000	0,000	0,000	83,180	-15,225	13,060	0,000

Tank Calibrations - diesel uso diaro estrib

Fluid Type = Fuel Oil Specific gravity = 0,9443

Permeability = 100 %

Trim = 0 m (+ve by stern); Heel = 0 deg to starboard

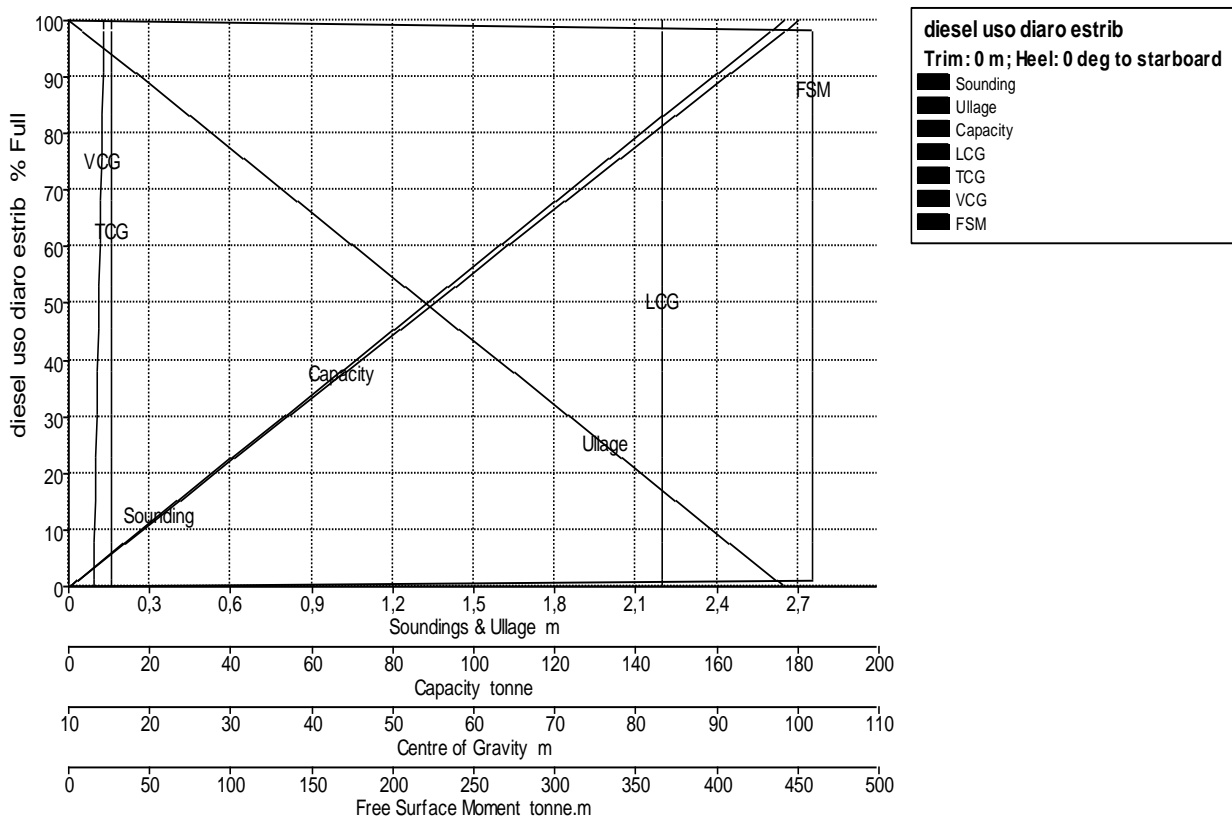

Tank Name	Sounding m	Ullage m	% Full	Capacity m ³	Capacity tonne	LCG m	TCG m	VCG m	FSM tonne.m
diesel uso diaro estrib	2,650	0,000	100,000	190,800	180,172	83,180	15,225	14,385	0,000
	2,600	0,050	98,113	187,200	176,773	83,180	15,225	14,360	458,930
	2,597	0,053	98,000	186,984	176,569	83,180	15,225	14,359	458,930
	2,594	0,056	97,900	186,793	176,389	83,180	15,225	14,357	458,930
	2,400	0,250	90,566	172,800	163,175	83,180	15,225	14,260	458,930

	2,200	0,450	83,019	158,400	149,577	83,180	15,225	14,160	458,930
	2,000	0,650	75,472	144,000	135,979	83,180	15,225	14,060	458,930
	1,800	0,850	67,925	129,600	122,381	83,180	15,225	13,960	458,930
	1,600	1,050	60,377	115,200	108,783	83,180	15,225	13,860	458,930
	1,400	1,250	52,830	100,800	95,185	83,180	15,225	13,760	458,930
	1,200	1,450	45,283	86,400	81,588	83,180	15,225	13,660	458,930
	1,000	1,650	37,736	72,000	67,990	83,180	15,225	13,560	458,930
	0,800	1,850	30,189	57,600	54,392	83,180	15,225	13,460	458,930
	0,600	2,050	22,642	43,200	40,794	83,180	15,225	13,360	458,930
	0,400	2,250	15,094	28,800	27,196	83,180	15,225	13,260	458,930
	0,200	2,450	7,547	14,400	13,598	83,180	15,225	13,160	458,930
	0,026	2,623	1,000	1,908	1,802	83,180	15,225	13,073	458,930
	0,000	2,650	0,000	0,000	0,000	83,180	15,225	13,060	0,000

Tank Calibrations - diesel sedimentacion bab

Fluid Type = Fuel Oil Specific gravity = 0,9443

Permeability = 100 %

Trim = 0 m (+ve by stern); Heel = 0 deg to starboard

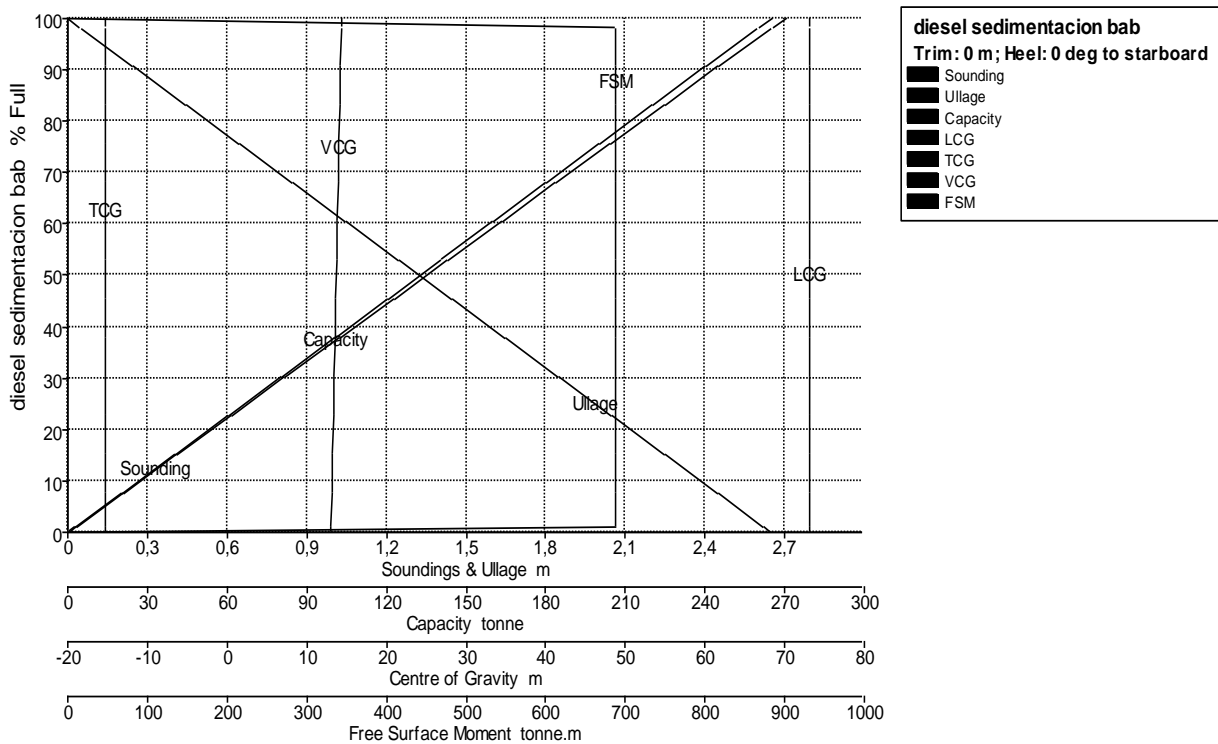

Tank Name	Sounding m	Ullage m	% Full	Capacity m ³	Capacity tonne	LCG m	TCG m	VCG m	FSM tonne.m
diesel sedimentacion bab	2,650	0,000	100,000	286,200	270,259	73,180	-15,225	14,385	0,000
	2,600	0,050	98,113	280,800	265,159	73,180	-15,225	14,360	688,395
	2,597	0,053	98,000	280,476	264,853	73,180	-15,225	14,359	688,395
	2,594	0,056	97,900	280,190	264,583	73,180	-15,225	14,357	688,395
	2,400	0,250	90,566	259,200	244,763	73,180	-15,225	14,260	688,395
	2,200	0,450	83,019	237,600	224,366	73,180	-15,225	14,160	688,395
	2,000	0,650	75,472	216,000	203,969	73,180	-15,225	14,060	688,395
	1,800	0,850	67,925	194,400	183,572	73,180	-15,225	13,960	688,395
	1,600	1,050	60,377	172,800	163,175	73,180	-15,225	13,860	688,395
	1,400	1,250	52,830	151,200	142,778	73,180	-15,225	13,760	688,395
	1,200	1,450	45,283	129,600	122,381	73,180	-15,225	13,660	688,395
	1,000	1,650	37,736	108,000	101,984	73,180	-15,225	13,560	688,395
	0,800	1,850	30,189	86,400	81,588	73,180	-15,225	13,460	688,395
	0,600	2,050	22,642	64,800	61,191	73,180	-15,225	13,360	688,395
	0,400	2,250	15,094	43,200	40,794	73,180	-15,225	13,260	688,395
	0,200	2,450	7,547	21,600	20,397	73,180	-15,225	13,160	688,395
	0,026	2,623	1,000	2,862	2,703	73,180	-15,225	13,073	688,395
	0,000	2,650	0,000	0,000	0,000	73,180	-15,225	13,060	0,000

Tank Calibrations - diesel sedimentacion estrib

Fluid Type = Fuel Oil Specific gravity = 0,9443

Permeability = 100 %

Trim = 0 m (+ve by stern); Heel = 0 deg to starboard

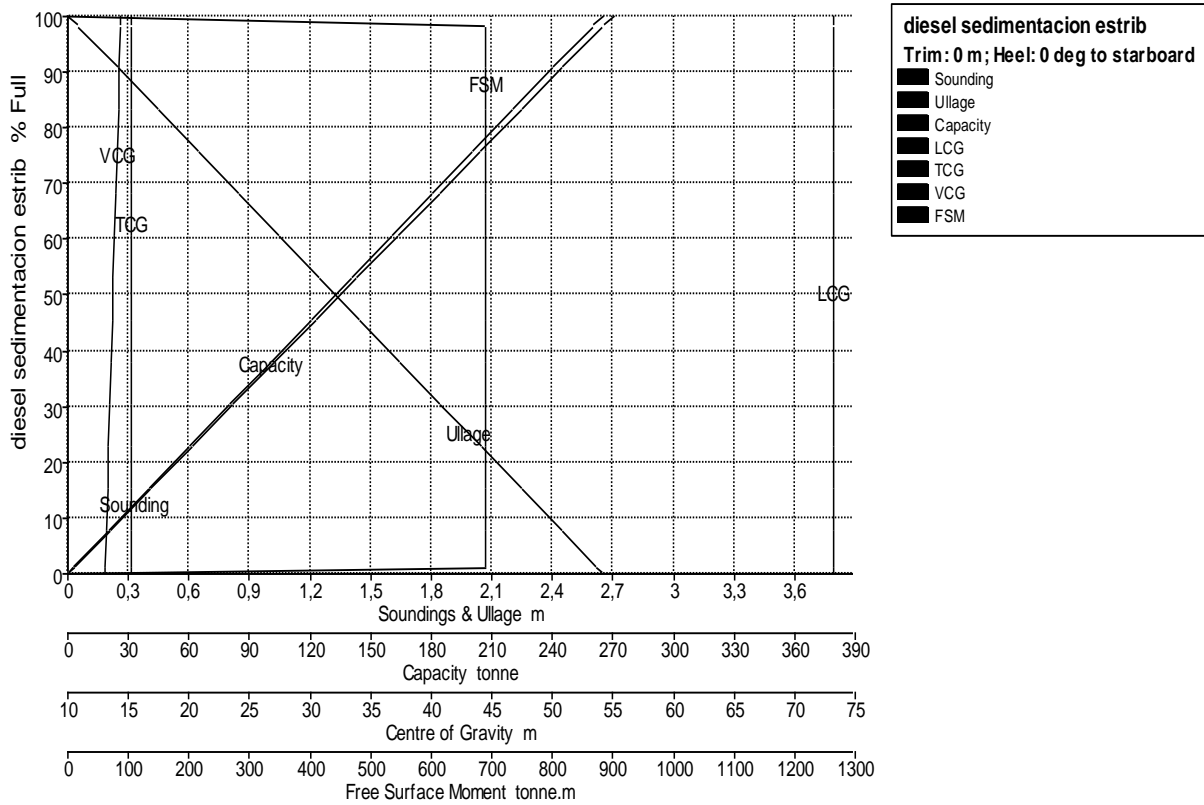

Tank Name	Sounding m	Ullage m	% Full	Capacity m ³	Capacity tonne	LCG m	TCG m	VCG m	FSM tonne.m
diesel sedimentacion estrib	2,650	0,000	100,000	286,200	270,259	73,180	15,225	14,385	0,000
	2,600	0,050	98,113	280,800	265,159	73,180	15,225	14,360	688,395
	2,597	0,053	98,000	280,476	264,853	73,180	15,225	14,359	688,395
	2,594	0,056	97,900	280,190	264,583	73,180	15,225	14,357	688,395
	2,400	0,250	90,566	259,200	244,763	73,180	15,225	14,260	688,395
	2,200	0,450	83,019	237,600	224,366	73,180	15,225	14,160	688,395
	2,000	0,650	75,472	216,000	203,969	73,180	15,225	14,060	688,395
	1,800	0,850	67,925	194,400	183,572	73,180	15,225	13,960	688,395
	1,600	1,050	60,377	172,800	163,175	73,180	15,225	13,860	688,395
	1,400	1,250	52,830	151,200	142,778	73,180	15,225	13,760	688,395
	1,200	1,450	45,283	129,600	122,381	73,180	15,225	13,660	688,395
	1,000	1,650	37,736	108,000	101,984	73,180	15,225	13,560	688,395
	0,800	1,850	30,189	86,400	81,588	73,180	15,225	13,460	688,395
	0,600	2,050	22,642	64,800	61,191	73,180	15,225	13,360	688,395

	0,400	2,250	15,094	43,200	40,794	73,180	15,225	13,260	688,395
	0,200	2,450	7,547	21,600	20,397	73,180	15,225	13,160	688,395
	0,026	2,623	1,000	2,862	2,703	73,180	15,225	13,073	688,395
	0,000	2,650	0,000	0,000	0,000	73,180	15,225	13,060	0,000

Tank Calibrations - aceite bab

Fluid Type = Lube Oil Specific gravity = 0,92

Permeability = 100 %

Trim = 0 m (+ve by stern); Heel = 0 deg to starboard

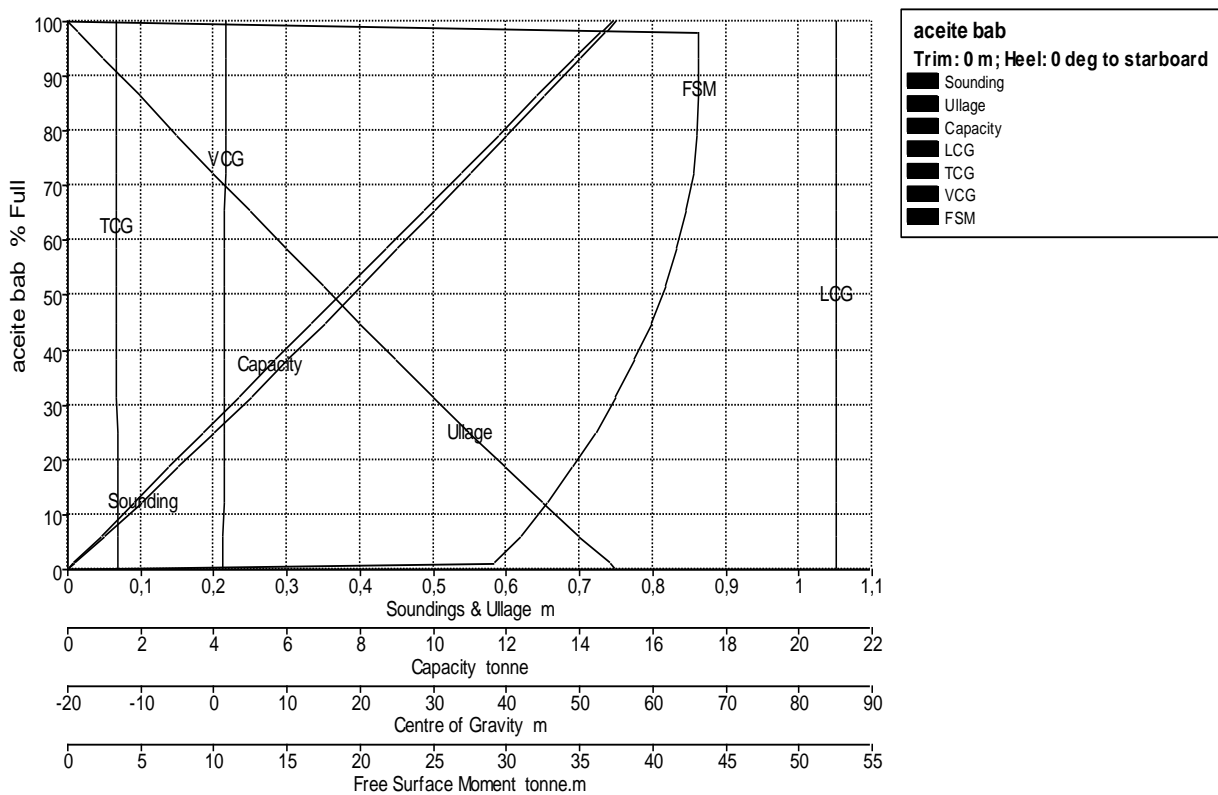

Tank Name	Sounding m	Ullage m	% Full	Capacity m ³	Capacity tonne	LCG m	TCG m	VCG m	FSM tonne.m
aceite bab	0,750	0,000	100,000	16,169	14,876	84,983	-13,409	1,634	0,000
	0,736	0,014	98,000	15,846	14,578	84,984	-13,407	1,627	43,125
	0,735	0,015	97,900	15,829	14,563	84,984	-13,407	1,627	43,125
	0,700	0,050	93,042	15,044	13,841	84,987	-13,402	1,609	43,125
	0,650	0,100	86,085	13,919	12,806	84,992	-13,394	1,583	43,125
	0,600	0,150	79,128	12,794	11,771	84,997	-13,385	1,558	43,051
	0,550	0,200	72,182	11,671	10,737	85,003	-13,374	1,532	42,768

	0,500	0,250	65,257	10,551	9,707	85,010	-13,362	1,506	42,278
	0,450	0,300	58,367	9,437	8,682	85,017	-13,348	1,480	41,666
	0,400	0,350	51,524	8,331	7,664	85,025	-13,333	1,455	40,839
	0,350	0,400	44,738	7,234	6,655	85,033	-13,316	1,429	39,860
	0,300	0,450	38,026	6,148	5,657	85,041	-13,298	1,403	38,767
	0,250	0,500	31,397	5,077	4,670	85,049	-13,279	1,377	37,447
	0,200	0,550	24,868	4,021	3,699	85,056	-13,258	1,351	36,095
	0,150	0,600	18,450	2,983	2,745	85,064	-13,235	1,326	34,442
	0,100	0,650	12,156	1,965	1,808	85,071	-13,211	1,300	32,763
	0,050	0,700	6,001	0,970	0,893	85,077	-13,185	1,275	30,874
	0,008	0,742	1,000	0,162	0,149	85,082	-13,162	1,254	29,142
	0,000	0,750	0,000	0,000	0,000	85,083	-13,157	1,250	0,000

Tank Calibrations - aceite estrib

Fluid Type = Lube Oil Specific gravity = 0,92

Permeability = 100 %

Trim = 0 m (+ve by stern); Heel = 0 deg to starboard

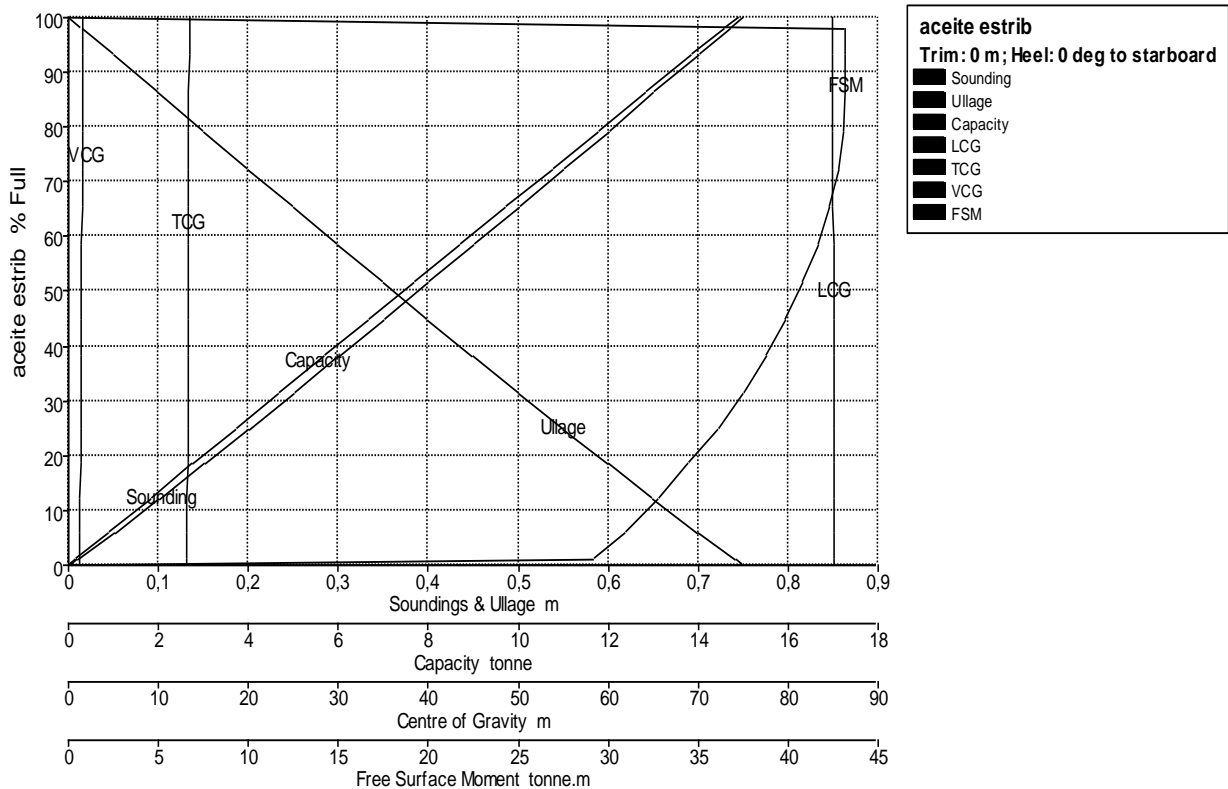

Tank Name	Sounding m	Ullage m	% Full	Capacity m ³	Capacity tonne	LCG m	TCG m	VCG m	FSM tonne.m
aceite estrib	0,750	0,000	100,000	16,169	14,876	84,983	13,409	1,634	0,000
	0,736	0,014	98,000	15,846	14,578	84,984	13,407	1,627	43,125
	0,735	0,015	97,900	15,829	14,563	84,984	13,407	1,627	43,125
	0,700	0,050	93,042	15,044	13,841	84,987	13,402	1,609	43,125
	0,650	0,100	86,085	13,919	12,806	84,992	13,394	1,583	43,125
	0,600	0,150	79,128	12,794	11,771	84,997	13,385	1,558	43,051
	0,550	0,200	72,182	11,671	10,737	85,003	13,374	1,532	42,768
	0,500	0,250	65,257	10,551	9,707	85,010	13,362	1,506	42,278
	0,450	0,300	58,367	9,437	8,682	85,017	13,348	1,480	41,666
	0,400	0,350	51,524	8,331	7,664	85,025	13,333	1,455	40,839
	0,350	0,400	44,738	7,234	6,655	85,033	13,316	1,429	39,860
	0,300	0,450	38,026	6,148	5,657	85,041	13,298	1,403	38,767
	0,250	0,500	31,397	5,077	4,670	85,049	13,279	1,377	37,447
	0,200	0,550	24,868	4,021	3,699	85,056	13,258	1,351	36,095
	0,150	0,600	18,450	2,983	2,745	85,064	13,235	1,326	34,442
	0,100	0,650	12,156	1,965	1,808	85,071	13,211	1,300	32,763
	0,050	0,700	6,001	0,970	0,893	85,077	13,185	1,275	30,874
	0,008	0,742	1,000	0,162	0,149	85,082	13,162	1,254	29,142
	0,000	0,750	0,000	0,000	0,000	85,083	13,157	1,250	0,000

Tank Calibrations - aceite usado bab

Fluid Type = Lube Oil Specific gravity = 0,92

Permeability = 100 %

Trim = 0 m (+ve by stern); Heel = 0 deg to starboard

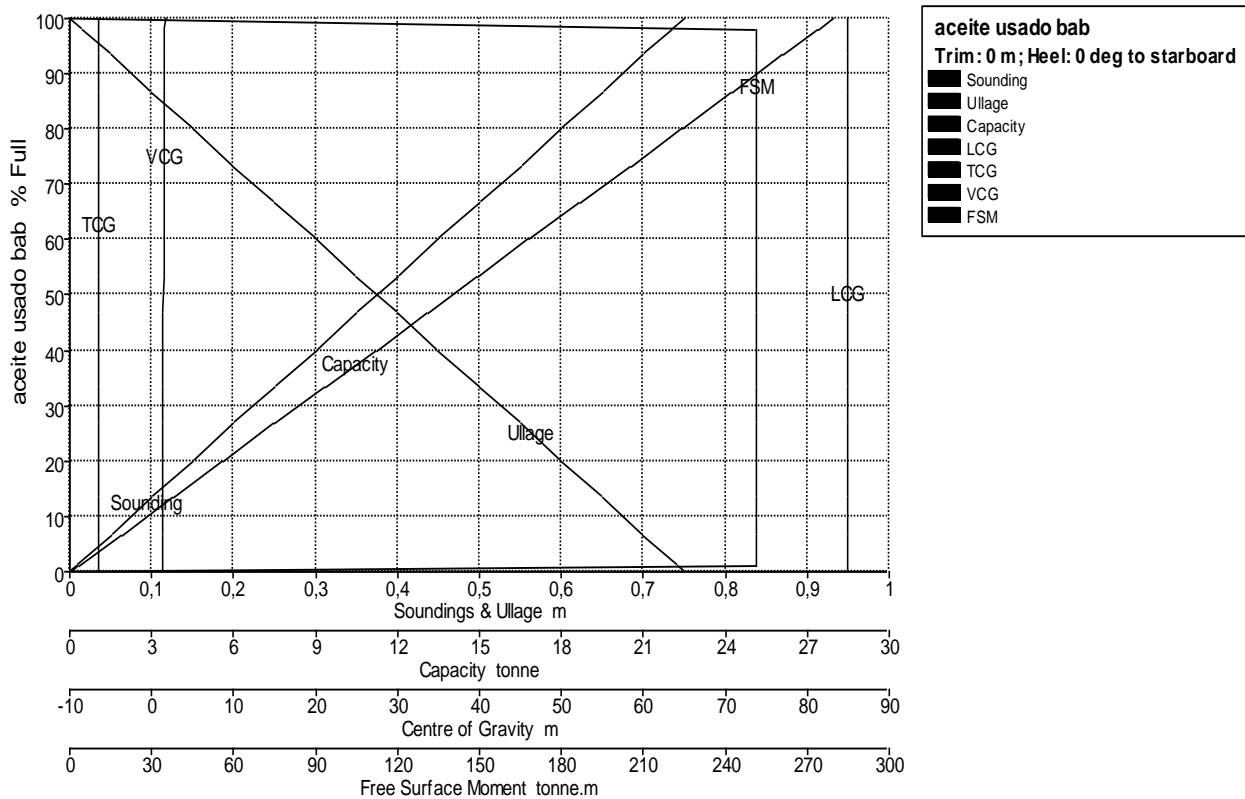

Tank Name	Sounding m	Ullage m	% Full	Capacity m ³	Capacity tonne	LCG m	TCG m	VCG m	FSM tonne.m
aceite usado bab	0,750	0,000	100,000	30,375	27,945	84,930	-6,500	1,625	0,000
	0,735	0,015	98,000	29,767	27,386	84,930	-6,500	1,618	251,505
	0,734	0,016	97,900	29,737	27,358	84,930	-6,500	1,617	251,505
	0,700	0,050	93,333	28,350	26,082	84,930	-6,500	1,600	251,505
	0,650	0,100	86,667	26,325	24,219	84,930	-6,500	1,575	251,505
	0,600	0,150	80,000	24,300	22,356	84,930	-6,500	1,550	251,505
	0,550	0,200	73,333	22,275	20,493	84,930	-6,500	1,525	251,505
	0,500	0,250	66,667	20,250	18,630	84,930	-6,500	1,500	251,505
	0,450	0,300	60,000	18,225	16,767	84,930	-6,500	1,475	251,505
	0,400	0,350	53,333	16,200	14,904	84,930	-6,500	1,450	251,505
	0,350	0,400	46,667	14,175	13,041	84,930	-6,500	1,425	251,505
	0,300	0,450	40,000	12,150	11,178	84,930	-6,500	1,400	251,505
	0,250	0,500	33,333	10,125	9,315	84,930	-6,500	1,375	251,505
	0,200	0,550	26,667	8,100	7,452	84,930	-6,500	1,350	251,505
	0,150	0,600	20,000	6,075	5,589	84,930	-6,500	1,325	251,505

	0,100	0,650	13,333	4,050	3,726	84,930	-6,500	1,300	251,505
	0,050	0,700	6,667	2,025	1,863	84,930	-6,500	1,275	251,505
	0,008	0,742	1,000	0,304	0,279	84,930	-6,500	1,254	251,505
	0,000	0,750	0,000	0,000	0,000	84,930	-6,500	1,250	0,000

Tank Calibrations - aceite usado estrib

Fluid Type = Lube Oil Specific gravity = 0,92

Permeability = 100 %

Trim = 0 m (+ve by stern); Heel = 0 deg to starboard

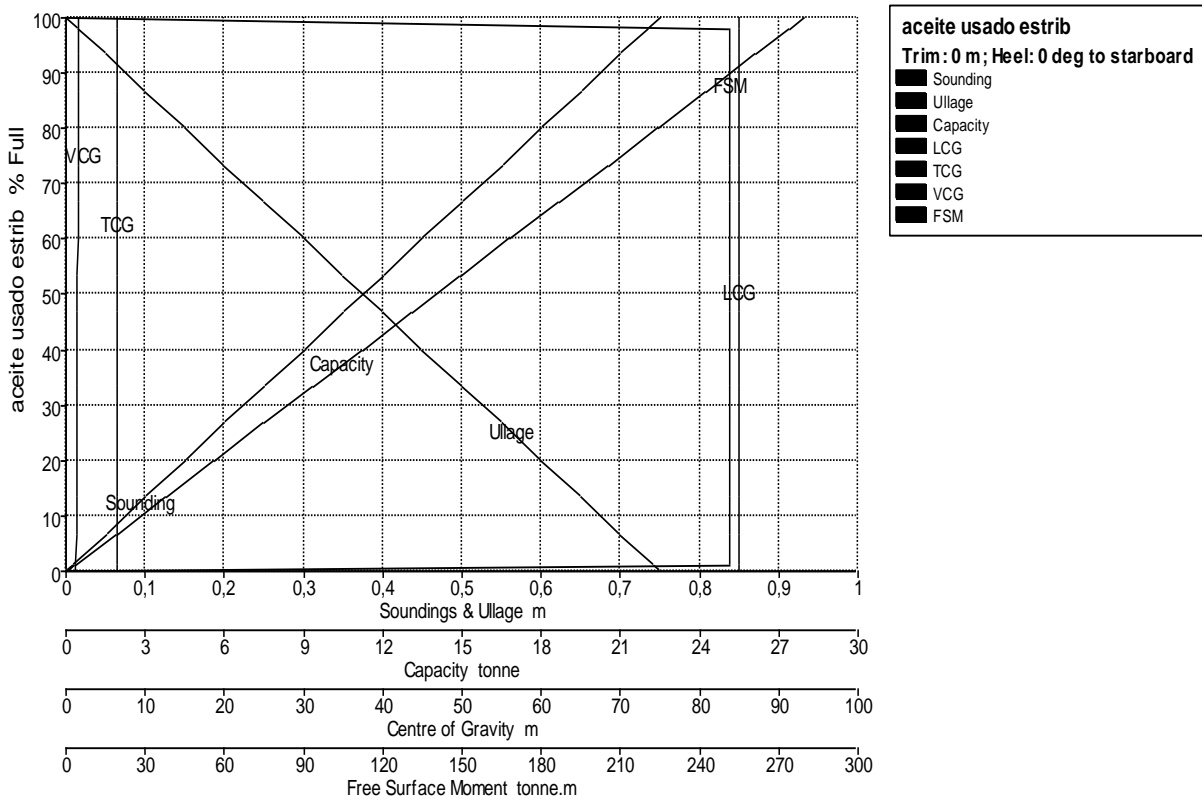

Tank Name	Sounding m	Ullage m	% Full	Capacity m ³	Capacity tonne	LCG m	TCG m	VCG m	FSM tonne.m
aceite usado estrib	0,750	0,000	100,000	30,375	27,945	84,930	6,500	1,625	0,000
	0,735	0,015	98,000	29,767	27,386	84,930	6,500	1,618	251,505
	0,734	0,016	97,900	29,737	27,358	84,930	6,500	1,617	251,505
	0,700	0,050	93,333	28,350	26,082	84,930	6,500	1,600	251,505
	0,650	0,100	86,667	26,325	24,219	84,930	6,500	1,575	251,505
	0,600	0,150	80,000	24,300	22,356	84,930	6,500	1,550	251,505

	0,550	0,200	73,333	22,275	20,493	84,930	6,500	1,525	251,505
	0,500	0,250	66,667	20,250	18,630	84,930	6,500	1,500	251,505
	0,450	0,300	60,000	18,225	16,767	84,930	6,500	1,475	251,505
	0,400	0,350	53,333	16,200	14,904	84,930	6,500	1,450	251,505
	0,350	0,400	46,667	14,175	13,041	84,930	6,500	1,425	251,505
	0,300	0,450	40,000	12,150	11,178	84,930	6,500	1,400	251,505
	0,250	0,500	33,333	10,125	9,315	84,930	6,500	1,375	251,505
	0,200	0,550	26,667	8,100	7,452	84,930	6,500	1,350	251,505
	0,150	0,600	20,000	6,075	5,589	84,930	6,500	1,325	251,505
	0,100	0,650	13,333	4,050	3,726	84,930	6,500	1,300	251,505
	0,050	0,700	6,667	2,025	1,863	84,930	6,500	1,275	251,505
	0,008	0,742	1,000	0,304	0,279	84,930	6,500	1,254	251,505
	0,000	0,750	0,000	0,000	0,000	84,930	6,500	1,250	0,000

Tank Calibrations - lodos bab

Fluid Type = Lube Oil Specific gravity = 0,92

Permeability = 100 %

Trim = 0 m (+ve by stern); Heel = 0 deg to starboard

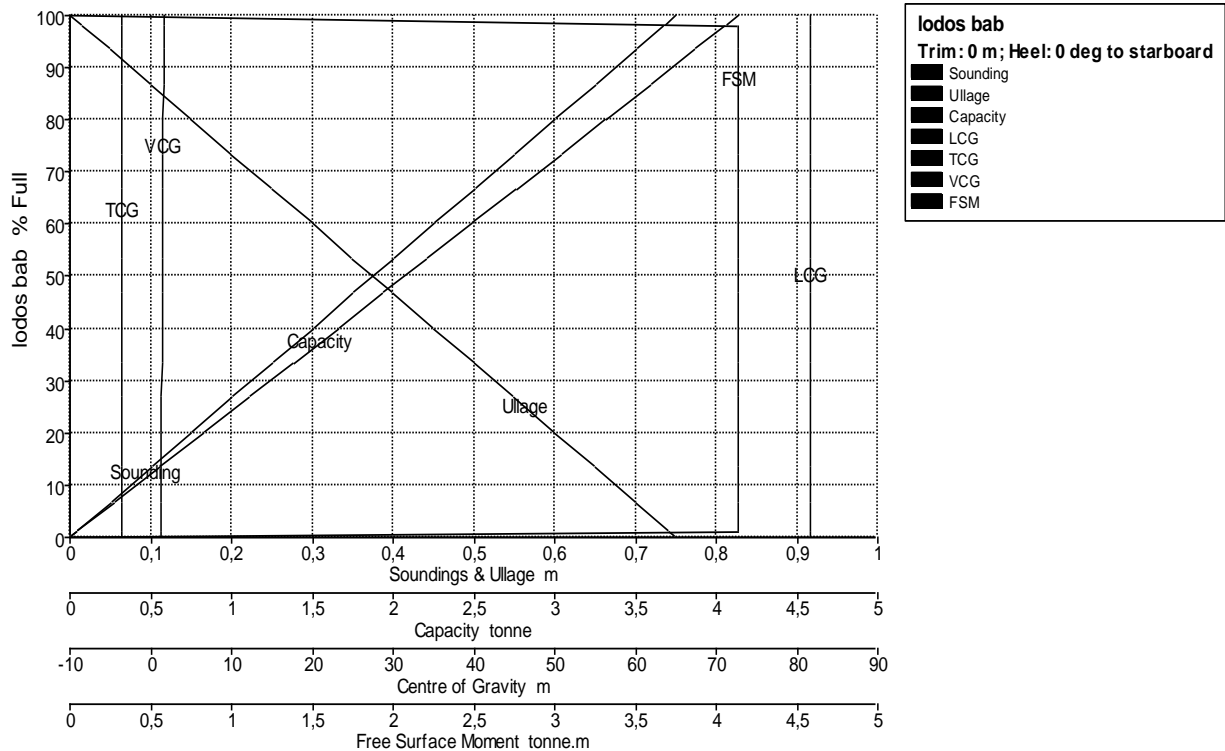

Tank Name	Sounding m	Ullage m	% Full	Capacity m ³	Capacity tonne	LCG m	TCG m	VCG m	FSM tonne.m
Iodos bab	0,750	0,000	100,000	4,500	4,140	81,680	-3,500	1,625	0,000
	0,735	0,015	98,000	4,410	4,057	81,680	-3,500	1,617	4,140
	0,734	0,016	97,900	4,405	4,053	81,680	-3,500	1,617	4,140
	0,700	0,050	93,333	4,200	3,864	81,680	-3,500	1,600	4,140
	0,650	0,100	86,667	3,900	3,588	81,680	-3,500	1,575	4,140
	0,600	0,150	80,000	3,600	3,312	81,680	-3,500	1,550	4,140
	0,550	0,200	73,333	3,300	3,036	81,680	-3,500	1,525	4,140
	0,500	0,250	66,667	3,000	2,760	81,680	-3,500	1,500	4,140
	0,450	0,300	60,000	2,700	2,484	81,680	-3,500	1,475	4,140
	0,400	0,350	53,333	2,400	2,208	81,680	-3,500	1,450	4,140
	0,350	0,400	46,667	2,100	1,932	81,680	-3,500	1,425	4,140
	0,300	0,450	40,000	1,800	1,656	81,680	-3,500	1,400	4,140
	0,250	0,500	33,333	1,500	1,380	81,680	-3,500	1,375	4,140
	0,200	0,550	26,667	1,200	1,104	81,680	-3,500	1,350	4,140
	0,150	0,600	20,000	0,900	0,828	81,680	-3,500	1,325	4,140
	0,100	0,650	13,333	0,600	0,552	81,680	-3,500	1,300	4,140
	0,050	0,700	6,667	0,300	0,276	81,680	-3,500	1,275	4,140
	0,008	0,742	1,000	0,045	0,041	81,680	-3,500	1,254	4,140
	0,000	0,750	0,000	0,000	0,000	81,680	-3,500	1,250	0,000

Tank Calibrations - Iodos estrib

Fluid Type = Lube Oil Specific gravity = 0,92

Permeability = 100 %

Trim = 0 m (+ve by stern); Heel = 0 deg to starboard

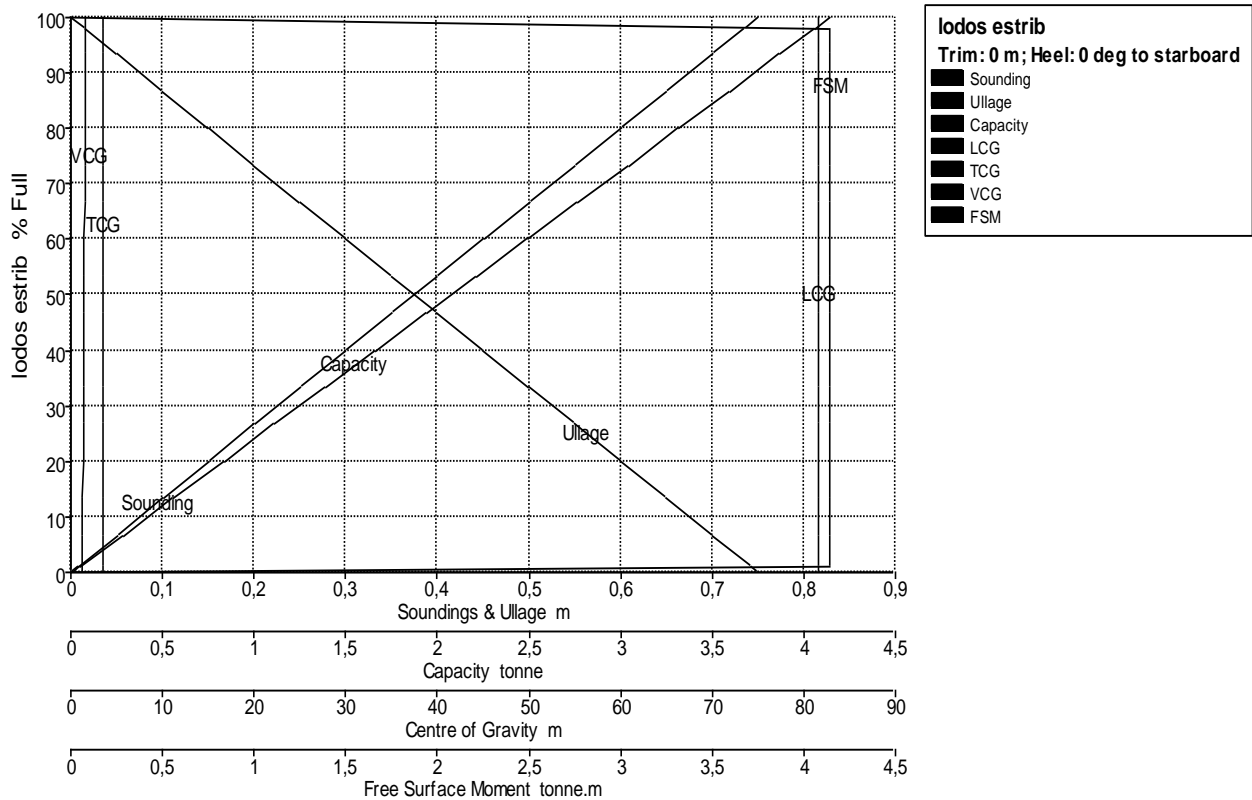

Tank Name	Sounding m	Ullage m	% Full	Capacity m ³	Capacity tonne	LCG m	TCG m	VCG m	FSM tonne.m
lodos estrib	0,750	0,000	100,000	4,500	4,140	81,680	3,500	1,625	0,000
	0,735	0,015	98,000	4,410	4,057	81,680	3,500	1,617	4,140
	0,734	0,016	97,900	4,405	4,053	81,680	3,500	1,617	4,140
	0,700	0,050	93,333	4,200	3,864	81,680	3,500	1,600	4,140
	0,650	0,100	86,667	3,900	3,588	81,680	3,500	1,575	4,140
	0,600	0,150	80,000	3,600	3,312	81,680	3,500	1,550	4,140
	0,550	0,200	73,333	3,300	3,036	81,680	3,500	1,525	4,140
	0,500	0,250	66,667	3,000	2,760	81,680	3,500	1,500	4,140
	0,450	0,300	60,000	2,700	2,484	81,680	3,500	1,475	4,140
	0,400	0,350	53,333	2,400	2,208	81,680	3,500	1,450	4,140
	0,350	0,400	46,667	2,100	1,932	81,680	3,500	1,425	4,140
	0,300	0,450	40,000	1,800	1,656	81,680	3,500	1,400	4,140
	0,250	0,500	33,333	1,500	1,380	81,680	3,500	1,375	4,140
	0,200	0,550	26,667	1,200	1,104	81,680	3,500	1,350	4,140

	0,150	0,600	20,000	0,900	0,828	81,680	3,500	1,325	4,140
	0,100	0,650	13,333	0,600	0,552	81,680	3,500	1,300	4,140
	0,050	0,700	6,667	0,300	0,276	81,680	3,500	1,275	4,140
	0,008	0,742	1,000	0,045	0,041	81,680	3,500	1,254	4,140
	0,000	0,750	0,000	0,000	0,000	81,680	3,500	1,250	0,000

Tank Calibrations - aguas residuales bab

Fluid Type = Fresh Water Specific gravity = 1

Permeability = 100 %

Trim = 0 m (+ve by stern); Heel = 0 deg to starboard

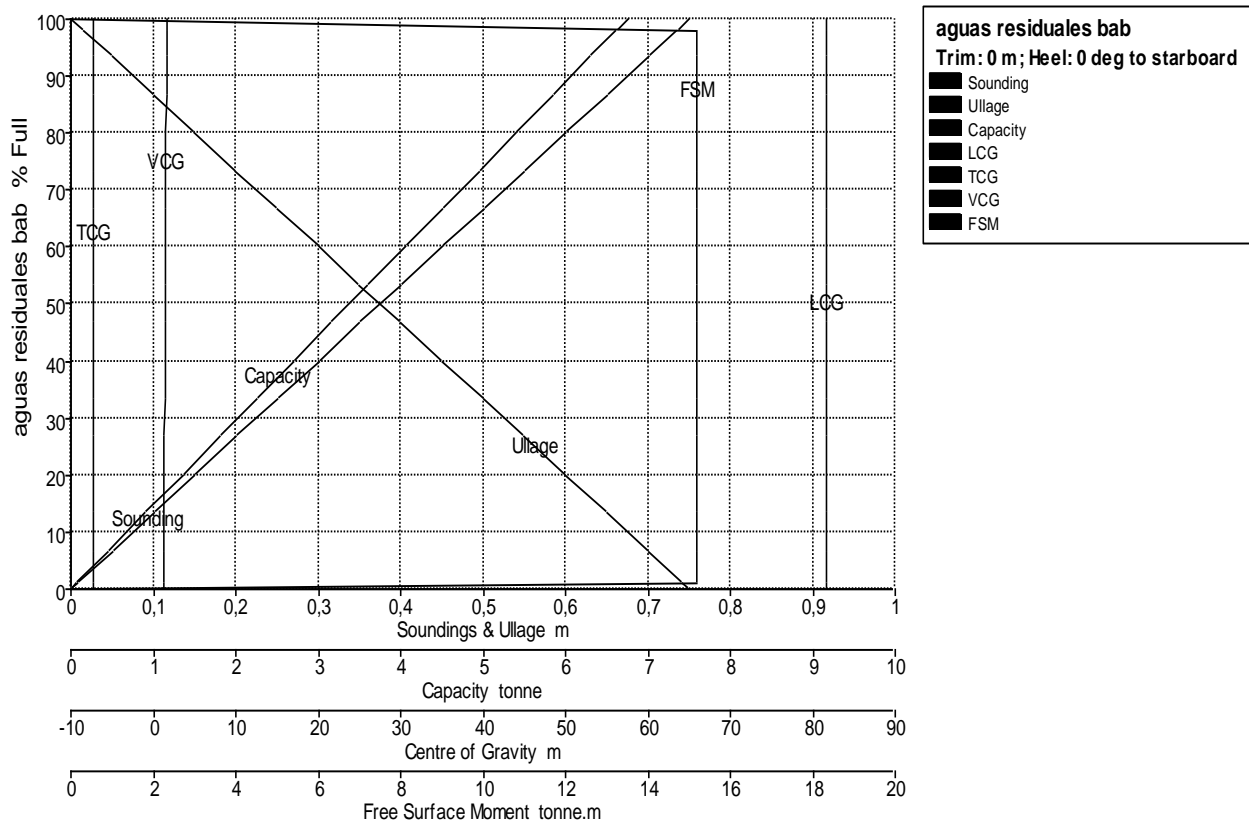

Tank Name	Sounding m	Ullage m	% Full	Capacity m ³	Capacity tonne	LCG m	TCG m	VCG m	FSM tonne.m
aguas residuales bab	0,750	0,000	100,000	6,750	6,750	81,680	-7,250	1,625	0,000
	0,735	0,015	98,000	6,615	6,615	81,680	-7,250	1,618	15,188
	0,734	0,016	97,900	6,608	6,608	81,680	-7,250	1,617	15,188
	0,700	0,050	93,333	6,300	6,300	81,680	-7,250	1,600	15,188

	0,650	0,100	86,667	5,850	5,850	81,680	-7,250	1,575	15,188
	0,600	0,150	80,000	5,400	5,400	81,680	-7,250	1,550	15,188
	0,550	0,200	73,333	4,950	4,950	81,680	-7,250	1,525	15,188
	0,500	0,250	66,667	4,500	4,500	81,680	-7,250	1,500	15,188
	0,450	0,300	60,000	4,050	4,050	81,680	-7,250	1,475	15,188
	0,400	0,350	53,333	3,600	3,600	81,680	-7,250	1,450	15,188
	0,350	0,400	46,667	3,150	3,150	81,680	-7,250	1,425	15,188
	0,300	0,450	40,000	2,700	2,700	81,680	-7,250	1,400	15,188
	0,250	0,500	33,333	2,250	2,250	81,680	-7,250	1,375	15,188
	0,200	0,550	26,667	1,800	1,800	81,680	-7,250	1,350	15,188
	0,150	0,600	20,000	1,350	1,350	81,680	-7,250	1,325	15,188
	0,100	0,650	13,333	0,900	0,900	81,680	-7,250	1,300	15,188
	0,050	0,700	6,667	0,450	0,450	81,680	-7,250	1,275	15,188
	0,008	0,742	1,000	0,068	0,068	81,680	-7,250	1,254	15,188
	0,000	0,750	0,000	0,000	0,000	81,680	-7,250	1,250	0,000

Tank Calibrations - aguas residuales estrib

Fluid Type = Fresh Water Specific gravity = 1

Permeability = 100 %

Trim = 0 m (+ve by stern); Heel = 0 deg to starboard

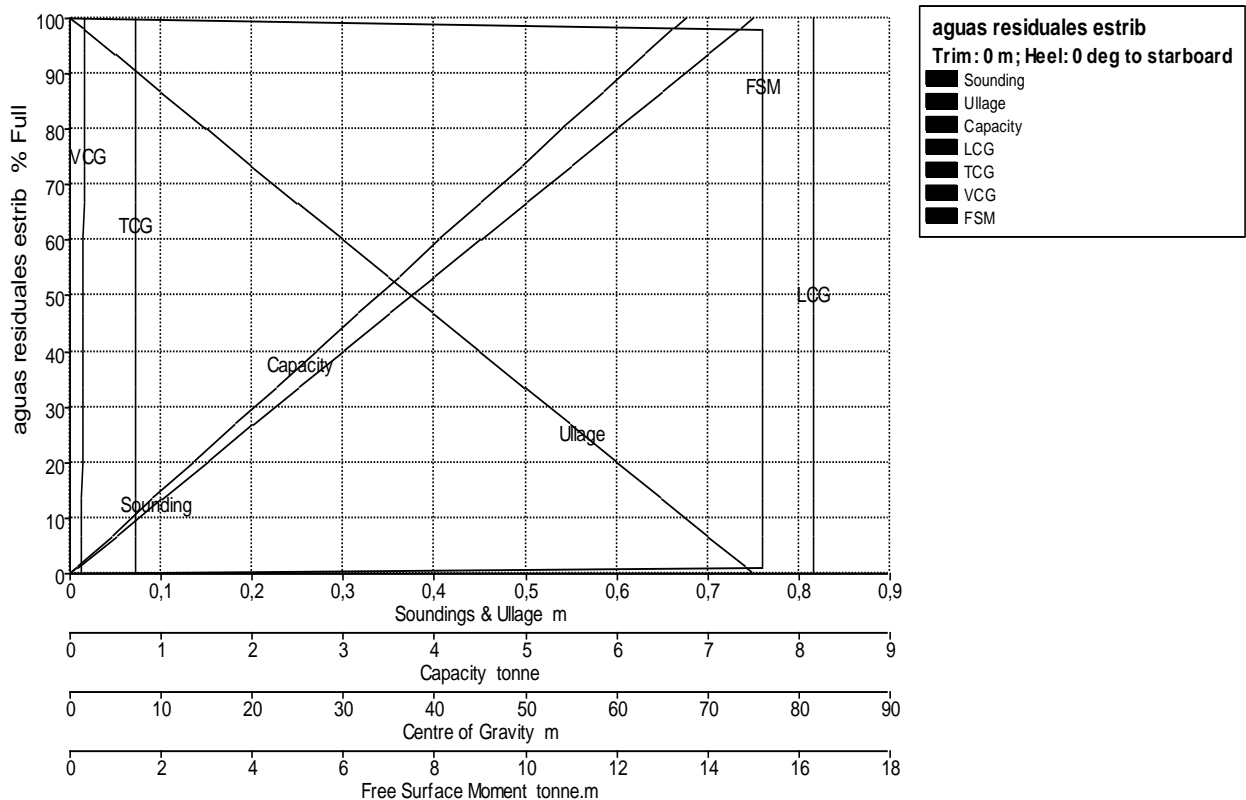

Tank Name	Sounding m	Ullage m	% Full	Capacity m³	Capacity tonne	LCG m	TCG m	VCG m	FSM tonne.m
aguas residuales estrib	0,750	0,000	100,000	6,750	6,750	81,680	7,250	1,625	0,000
	0,735	0,015	98,000	6,615	6,615	81,680	7,250	1,618	15,188
	0,734	0,016	97,900	6,608	6,608	81,680	7,250	1,617	15,188
	0,700	0,050	93,333	6,300	6,300	81,680	7,250	1,600	15,188
	0,650	0,100	86,667	5,850	5,850	81,680	7,250	1,575	15,188
	0,600	0,150	80,000	5,400	5,400	81,680	7,250	1,550	15,188
	0,550	0,200	73,333	4,950	4,950	81,680	7,250	1,525	15,188
	0,500	0,250	66,667	4,500	4,500	81,680	7,250	1,500	15,188
	0,450	0,300	60,000	4,050	4,050	81,680	7,250	1,475	15,188
	0,400	0,350	53,333	3,600	3,600	81,680	7,250	1,450	15,188
	0,350	0,400	46,667	3,150	3,150	81,680	7,250	1,425	15,188
	0,300	0,450	40,000	2,700	2,700	81,680	7,250	1,400	15,188
	0,250	0,500	33,333	2,250	2,250	81,680	7,250	1,375	15,188
	0,200	0,550	26,667	1,800	1,800	81,680	7,250	1,350	15,188
	0,150	0,600	20,000	1,350	1,350	81,680	7,250	1,325	15,188
	0,100	0,650	13,333	0,900	0,900	81,680	7,250	1,300	15,188
	0,050	0,700	6,667	0,450	0,450	81,680	7,250	1,275	15,188
	0,008	0,742	1,000	0,068	0,068	81,680	7,250	1,254	15,188
	0,000	0,750	0,000	0,000	0,000	81,680	7,250	1,250	0,000

Tank Calibrations - fuel oil 1 bab

Fluid Type = Fuel Oil Specific gravity = 0,9443

Permeability = 100 %

Trim = 0 m (+ve by stern); Heel = 0 deg to starboard

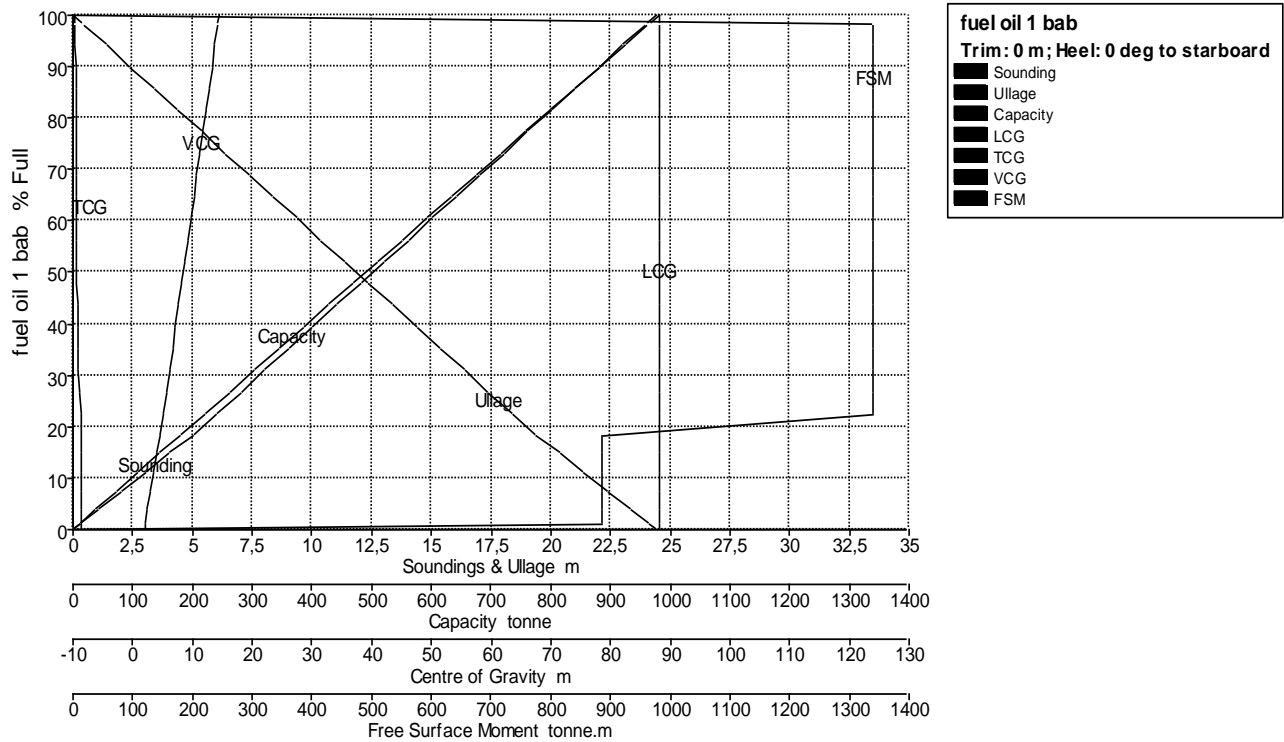

Tank Name	Sounding m	Ullage m	% Full	Capacity m ³	Capacity tonne	LCG m	TCG m	VCG m	FSM tonne.m
fuel oil 1 bab	24,410	0,000	100,000	1039,017	981,143	88,290	-9,615	14,480	0,000
	24,000	0,410	98,272	1021,063	964,190	88,290	-9,611	14,274	1340,704
	23,935	0,475	98,000	1018,236	961,521	88,290	-9,610	14,241	1340,704
	23,912	0,498	97,900	1017,197	960,539	88,290	-9,610	14,229	1340,704
	23,000	1,410	94,058	977,273	922,839	88,290	-9,600	13,771	1340,704
	22,000	2,410	89,843	933,484	881,489	88,290	-9,587	13,267	1340,704
	21,000	3,410	85,629	889,694	840,138	88,290	-9,574	12,764	1340,704
	20,000	4,410	81,414	845,905	798,788	88,290	-9,559	12,260	1340,704
	19,000	5,410	77,199	802,115	757,437	88,290	-9,542	11,755	1340,704
	18,000	6,410	72,985	758,326	716,087	88,290	-9,524	11,250	1340,704
	17,000	7,410	68,770	714,536	674,737	88,290	-9,503	10,745	1340,704
	16,000	8,410	64,556	670,747	633,386	88,290	-9,480	10,238	1340,704
	15,000	9,410	60,341	626,957	592,036	88,290	-9,453	9,731	1340,704
	14,000	10,410	56,127	583,168	550,685	88,290	-9,422	9,223	1340,704
	13,000	11,410	51,912	539,378	509,335	88,290	-9,386	8,713	1340,704
	12,000	12,410	47,698	495,589	467,984	88,290	-9,344	8,202	1340,704
	11,000	13,410	43,483	451,799	426,634	88,290	-9,294	7,689	1340,704

	10,000	14,410	39,269	408,010	385,283	88,290	-9,233	7,172	1340,704
	9,000	15,410	35,054	364,220	343,933	88,290	-9,157	6,652	1340,704
	8,000	16,410	30,840	320,431	302,583	88,290	-9,061	6,126	1340,704
	7,000	17,410	26,625	276,641	261,232	88,290	-8,934	5,592	1340,704
	6,000	18,410	22,411	232,851	219,882	88,290	-8,760	5,045	1340,704
	5,000	19,410	18,359	190,754	180,129	88,290	-8,592	4,500	886,606
	4,000	20,410	14,687	152,603	144,103	88,290	-8,592	4,000	886,606
	3,000	21,410	11,015	114,452	108,077	88,290	-8,592	3,500	886,606
	2,000	22,410	7,344	76,301	72,051	88,290	-8,592	3,000	886,606
	1,000	23,410	3,672	38,151	36,026	88,290	-8,592	2,500	886,606
	0,272	24,138	1,000	10,390	9,811	88,290	-8,592	2,136	886,606
	0,000	24,410	0,000	0,000	0,000	88,290	-8,592	2,000	0,000

Tank Calibrations - fuel oil 1 estrib

Fluid Type = Fuel Oil Specific gravity = 0,9443

Permeability = 100 %

Trim = 0 m (+ve by stern); Heel = 0 deg to starboard

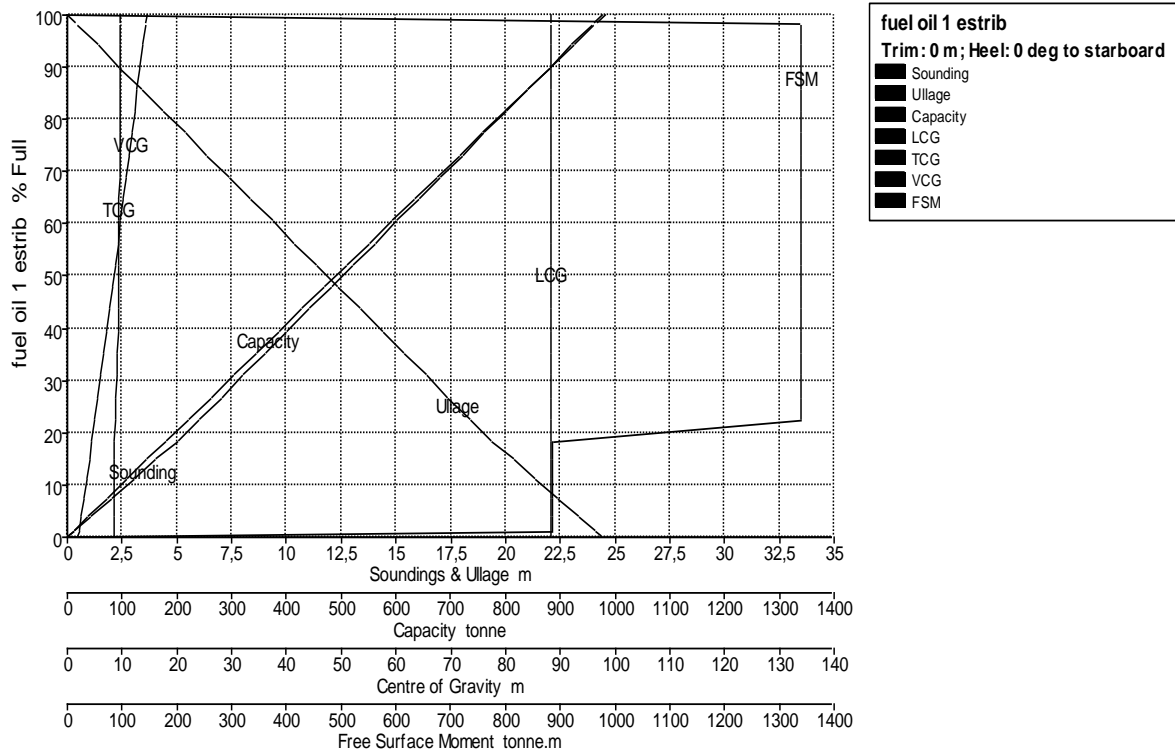

Tank Name	Sounding m	Ullage m	% Full	Capacity m ³	Capacity tonne	LCG m	TCG m	VCG m	FSM tonne.m
fuel oil 1 estrib	24,410	0,000	100,000	1039,017	981,143	88,290	9,615	14,480	0,000
	24,000	0,410	98,272	1021,063	964,190	88,290	9,611	14,274	1340,704
	23,935	0,475	98,000	1018,236	961,521	88,290	9,610	14,241	1340,704
	23,912	0,498	97,900	1017,197	960,539	88,290	9,610	14,229	1340,704
	23,000	1,410	94,058	977,273	922,839	88,290	9,600	13,771	1340,704
	22,000	2,410	89,843	933,484	881,489	88,290	9,587	13,267	1340,704
	21,000	3,410	85,629	889,694	840,138	88,290	9,574	12,764	1340,704
	20,000	4,410	81,414	845,905	798,788	88,290	9,559	12,260	1340,704
	19,000	5,410	77,199	802,115	757,437	88,290	9,542	11,755	1340,704
	18,000	6,410	72,985	758,326	716,087	88,290	9,524	11,250	1340,704
	17,000	7,410	68,770	714,536	674,737	88,290	9,503	10,745	1340,704
	16,000	8,410	64,556	670,747	633,386	88,290	9,480	10,238	1340,704
	15,000	9,410	60,341	626,957	592,036	88,290	9,453	9,731	1340,704
	14,000	10,410	56,127	583,168	550,685	88,290	9,422	9,223	1340,704
	13,000	11,410	51,912	539,378	509,335	88,290	9,386	8,713	1340,704
	12,000	12,410	47,698	495,589	467,984	88,290	9,344	8,202	1340,704
	11,000	13,410	43,483	451,799	426,634	88,290	9,294	7,689	1340,704
	10,000	14,410	39,269	408,010	385,283	88,290	9,233	7,172	1340,704
	9,000	15,410	35,054	364,220	343,933	88,290	9,157	6,652	1340,704
	8,000	16,410	30,840	320,431	302,583	88,290	9,061	6,126	1340,704

	7,000	17,410	26,625	276,641	261,232	88,290	8,934	5,592	1340,704
	6,000	18,410	22,411	232,851	219,882	88,290	8,760	5,045	1340,704
	5,000	19,410	18,359	190,754	180,129	88,290	8,592	4,500	886,606
	4,000	20,410	14,687	152,603	144,103	88,290	8,592	4,000	886,606
	3,000	21,410	11,015	114,452	108,077	88,290	8,592	3,500	886,606
	2,000	22,410	7,344	76,301	72,051	88,290	8,592	3,000	886,606
	1,000	23,410	3,672	38,151	36,026	88,290	8,592	2,500	886,606
	0,272	24,138	1,000	10,390	9,811	88,290	8,592	2,136	886,606
	0,000	24,410	0,000	0,000	0,000	88,290	8,592	2,000	0,000

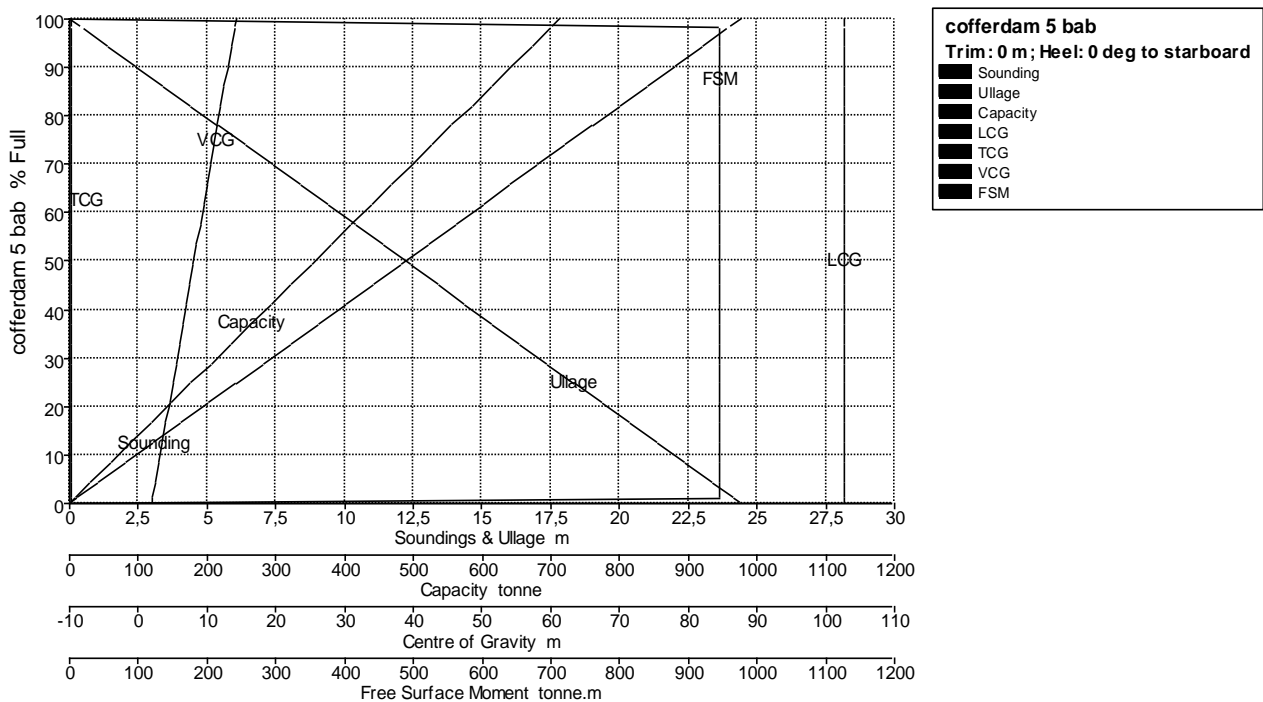

Tank Calibrations - cofferdam 5 bab

Fluid Type = Specific gravity = 1

Permeability = 100 %

Trim = 0 m (+ve by stern); Heel = 0 deg to starboard

Tank Name	Soundi ng m	Ullage m	% Full	Capacity m^3	Capacity tonne	LCG m	TCG m	VCG m	FSM tonne.m
cofferdam 5 bab	24,410	0,000	100,000	712,599	712,599	102,720	-9,863	14,205	0,000
	24,000	0,410	98,320	700,630	700,630	102,720	-9,863	14,000	946,521
	23,922	0,488	98,000	698,347	698,347	102,720	-9,863	13,961	946,521
	23,897	0,513	97,900	697,635	697,635	102,720	-9,863	13,949	946,521
	23,000	1,410	94,224	671,437	671,437	102,720	-9,863	13,500	946,521
	22,000	2,410	90,127	642,244	642,244	102,720	-9,863	13,000	946,521
	21,000	3,410	86,030	613,051	613,051	102,720	-9,863	12,500	946,521
	20,000	4,410	81,934	583,858	583,858	102,720	-9,863	12,000	946,521
	19,000	5,410	77,837	554,665	554,665	102,720	-9,863	11,500	946,521
	18,000	6,410	73,740	525,472	525,472	102,720	-9,863	11,000	946,521
	17,000	7,410	69,644	496,280	496,280	102,720	-9,863	10,500	946,521
	16,000	8,410	65,547	467,087	467,087	102,720	-9,863	10,000	946,521
	15,000	9,410	61,450	437,894	437,894	102,720	-9,863	9,500	946,521
	14,000	10,410	57,354	408,701	408,701	102,720	-9,863	9,000	946,521
	13,000	11,410	53,257	379,508	379,508	102,720	-9,863	8,500	946,521
	12,000	12,410	49,160	350,315	350,315	102,720	-9,863	8,000	946,521
	11,000	13,410	45,063	321,122	321,122	102,720	-9,863	7,500	946,521
	10,000	14,410	40,967	291,929	291,929	102,720	-9,863	7,000	946,521
	9,000	15,410	36,870	262,736	262,736	102,720	-9,863	6,500	946,521
	8,000	16,410	32,773	233,543	233,543	102,720	-9,863	6,000	946,521
	7,000	17,410	28,677	204,350	204,350	102,720	-9,863	5,500	946,521
	6,000	18,410	24,580	175,157	175,157	102,720	-9,863	5,000	946,521
	5,000	19,410	20,483	145,965	145,965	102,720	-9,863	4,500	946,521
	4,000	20,410	16,387	116,772	116,772	102,720	-9,863	4,000	946,521
	3,000	21,410	12,290	87,579	87,579	102,720	-9,863	3,500	946,521
	2,000	22,410	8,193	58,386	58,386	102,720	-9,863	3,000	946,521
	1,000	23,410	4,097	29,193	29,193	102,720	-9,863	2,500	946,521
	0,244	24,166	1,000	7,126	7,126	102,720	-9,863	2,122	946,521
	0,000	24,410	0,000	0,000	0,000	102,720	-9,863	2,000	0,000

Tank Calibrations - cofferdam 5 estrib

Fluid Type = Specific gravity = 1

Permeability = 100 %

Trim = 0 m (+ve by stern); Heel = 0 deg to starboard

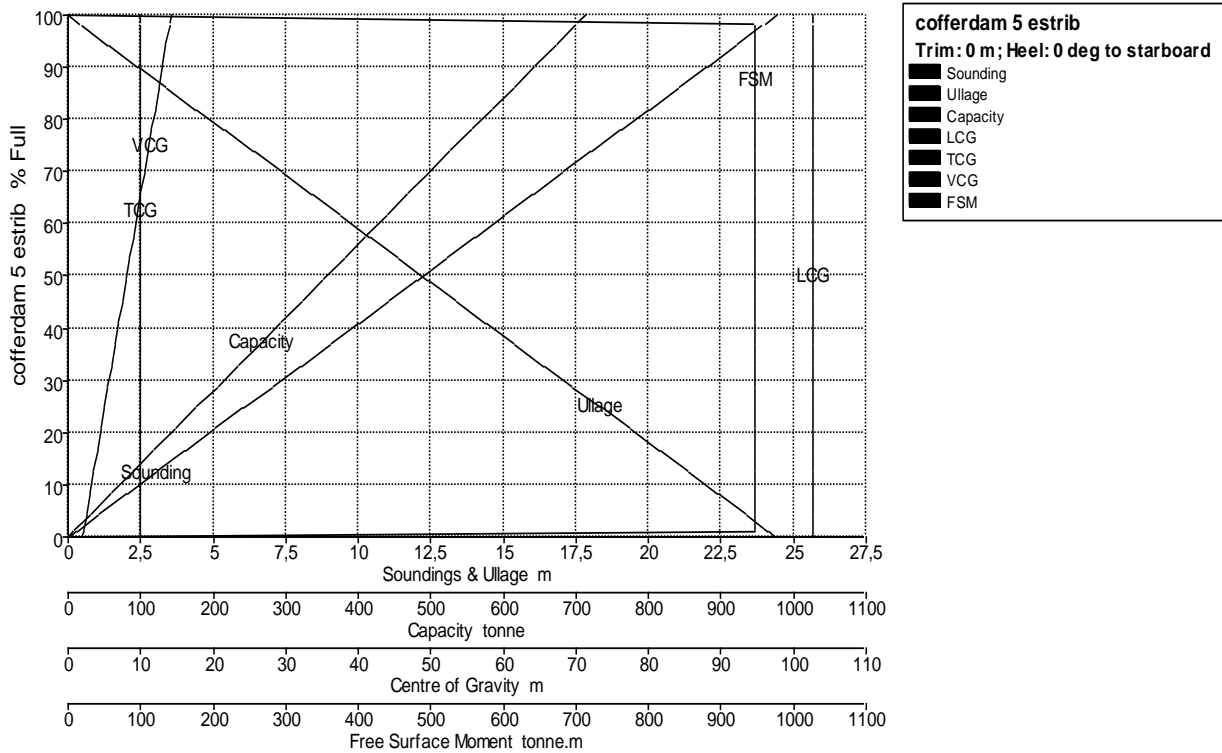

Tank Name	Sounding m	Ullage m	% Full	Capacity m ³	Capacity tonne	LCG m	TCG m	VCG m	FSM tonne.m
cofferdam 5 estrib	24,410	0,000	100,000	712,599	712,599	102,720	9,863	14,205	0,000
	24,000	0,410	98,320	700,630	700,630	102,720	9,863	14,000	946,521
	23,922	0,488	98,000	698,347	698,347	102,720	9,863	13,961	946,521
	23,897	0,513	97,900	697,635	697,635	102,720	9,863	13,949	946,521
	23,000	1,410	94,224	671,437	671,437	102,720	9,863	13,500	946,521
	22,000	2,410	90,127	642,244	642,244	102,720	9,863	13,000	946,521
	21,000	3,410	86,030	613,051	613,051	102,720	9,863	12,500	946,521
	20,000	4,410	81,934	583,858	583,858	102,720	9,863	12,000	946,521
	19,000	5,410	77,837	554,665	554,665	102,720	9,863	11,500	946,521
	18,000	6,410	73,740	525,472	525,472	102,720	9,863	11,000	946,521
	17,000	7,410	69,644	496,280	496,280	102,720	9,863	10,500	946,521
	16,000	8,410	65,547	467,087	467,087	102,720	9,863	10,000	946,521
	15,000	9,410	61,450	437,894	437,894	102,720	9,863	9,500	946,521
	14,000	10,410	57,354	408,701	408,701	102,720	9,863	9,000	946,521
	13,000	11,410	53,257	379,508	379,508	102,720	9,863	8,500	946,521

	12,000	12,410	49,160	350,315	350,315	102,720	9,863	8,000	946,521
	11,000	13,410	45,063	321,122	321,122	102,720	9,863	7,500	946,521
	10,000	14,410	40,967	291,929	291,929	102,720	9,863	7,000	946,521
	9,000	15,410	36,870	262,736	262,736	102,720	9,863	6,500	946,521
	8,000	16,410	32,773	233,543	233,543	102,720	9,863	6,000	946,521
	7,000	17,410	28,677	204,350	204,350	102,720	9,863	5,500	946,521
	6,000	18,410	24,580	175,157	175,157	102,720	9,863	5,000	946,521
	5,000	19,410	20,483	145,965	145,965	102,720	9,863	4,500	946,521
	4,000	20,410	16,387	116,772	116,772	102,720	9,863	4,000	946,521
	3,000	21,410	12,290	87,579	87,579	102,720	9,863	3,500	946,521
	2,000	22,410	8,193	58,386	58,386	102,720	9,863	3,000	946,521
	1,000	23,410	4,097	29,193	29,193	102,720	9,863	2,500	946,521
	0,244	24,166	1,000	7,126	7,126	102,720	9,863	2,122	946,521
	0,000	24,410	0,000	0,000	0,000	102,720	9,863	2,000	0,000

Tank Calibrations - fuel oil 2 bab

Fluid Type = Fuel Oil Specific gravity = 0,9443

Permeability = 100 %

Trim = 0 m (+ve by stern); Heel = 0 deg to starboard

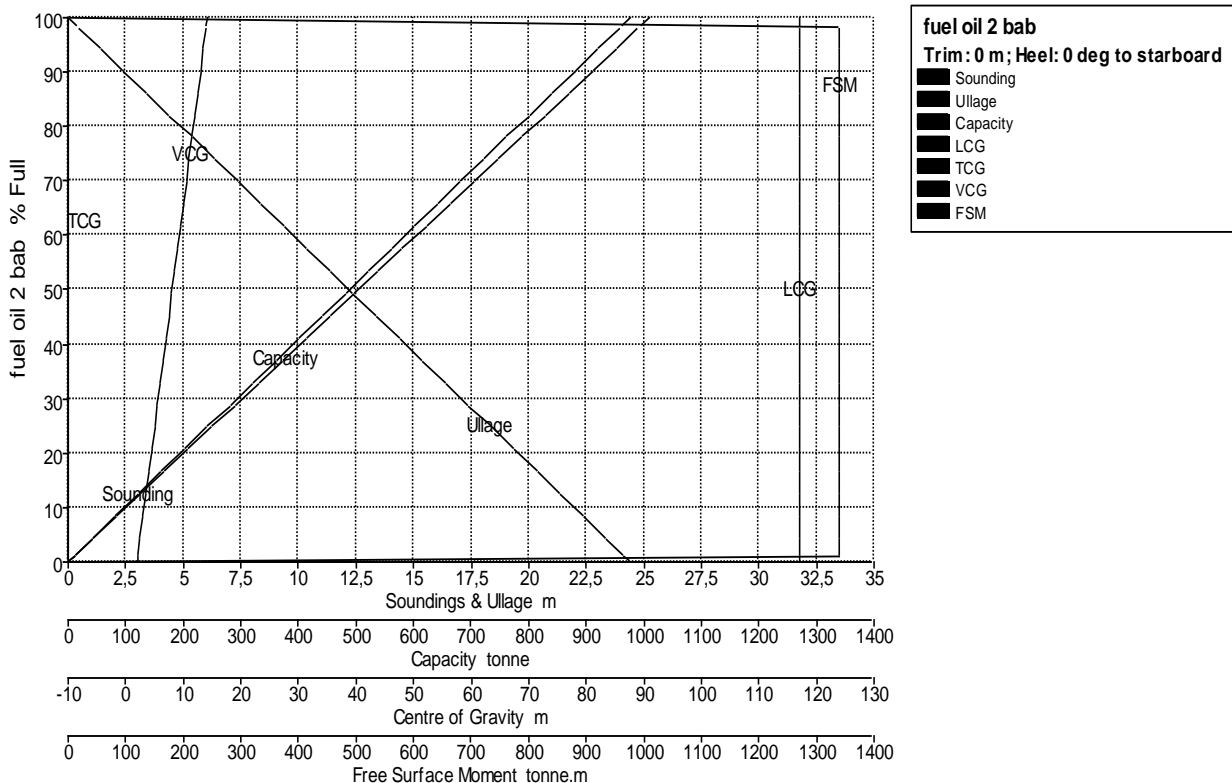

Tank Name	Sounding m	Ullage m	% Full	Capacity m ³	Capacity tonne	LCG m	TCG m	VCG m	FSM tonne.m
fuel oil 2 bab	24,410	0,000	100,000	1068,902	1009,364	117,150	-9,863	14,205	0,000
	24,000	0,410	98,320	1050,949	992,411	117,150	-9,863	14,000	1340,704
	23,922	0,488	98,000	1047,524	989,177	117,150	-9,863	13,961	1340,704
	23,897	0,513	97,900	1046,455	988,168	117,150	-9,863	13,949	1340,704
	23,000	1,410	94,224	1007,159	951,060	117,150	-9,863	13,500	1340,704
	22,000	2,410	90,127	963,370	909,710	117,150	-9,863	13,000	1340,704
	21,000	3,410	86,030	919,580	868,359	117,150	-9,863	12,500	1340,704
	20,000	4,410	81,934	875,790	827,009	117,150	-9,863	12,000	1340,704
	19,000	5,410	77,837	832,001	785,659	117,150	-9,863	11,500	1340,704
	18,000	6,410	73,740	788,211	744,308	117,150	-9,863	11,000	1340,704
	17,000	7,410	69,644	744,422	702,958	117,150	-9,863	10,500	1340,704
	16,000	8,410	65,547	700,632	661,607	117,150	-9,863	10,000	1340,704
	15,000	9,410	61,450	656,843	620,257	117,150	-9,863	9,500	1340,704
	14,000	10,410	57,354	613,053	578,906	117,150	-9,863	9,000	1340,704
	13,000	11,410	53,257	569,264	537,556	117,150	-9,863	8,500	1340,704
	12,000	12,410	49,160	525,474	496,205	117,150	-9,863	8,000	1340,704
	11,000	13,410	45,063	481,685	454,855	117,150	-9,863	7,500	1340,704
	10,000	14,410	40,967	437,895	413,504	117,150	-9,863	7,000	1340,704
	9,000	15,410	36,870	394,106	372,154	117,150	-9,863	6,500	1340,704
	8,000	16,410	32,773	350,316	330,804	117,150	-9,863	6,000	1340,704
	7,000	17,410	28,677	306,527	289,453	117,150	-9,863	5,500	1340,704
	6,000	18,410	24,580	262,737	248,103	117,150	-9,863	5,000	1340,704
	5,000	19,410	20,483	218,948	206,752	117,150	-9,863	4,500	1340,704
	4,000	20,410	16,387	175,158	165,402	117,150	-9,863	4,000	1340,704
	3,000	21,410	12,290	131,369	124,051	117,150	-9,863	3,500	1340,704
	2,000	22,410	8,193	87,579	82,701	117,150	-9,863	3,000	1340,704
	1,000	23,410	4,097	43,790	41,350	117,150	-9,863	2,500	1340,704
	0,244	24,166	1,000	10,689	10,094	117,150	-9,863	2,122	1340,704
	0,000	24,410	0,000	0,000	0,000	117,150	-9,863	2,000	0,000

Tank Calibrations - fuel oil 2 estrib

Fluid Type = Fuel Oil Specific gravity = 0,9443

Permeability = 100 %

Trim = 0 m (+ve by stern); Heel = 0 deg to starboard

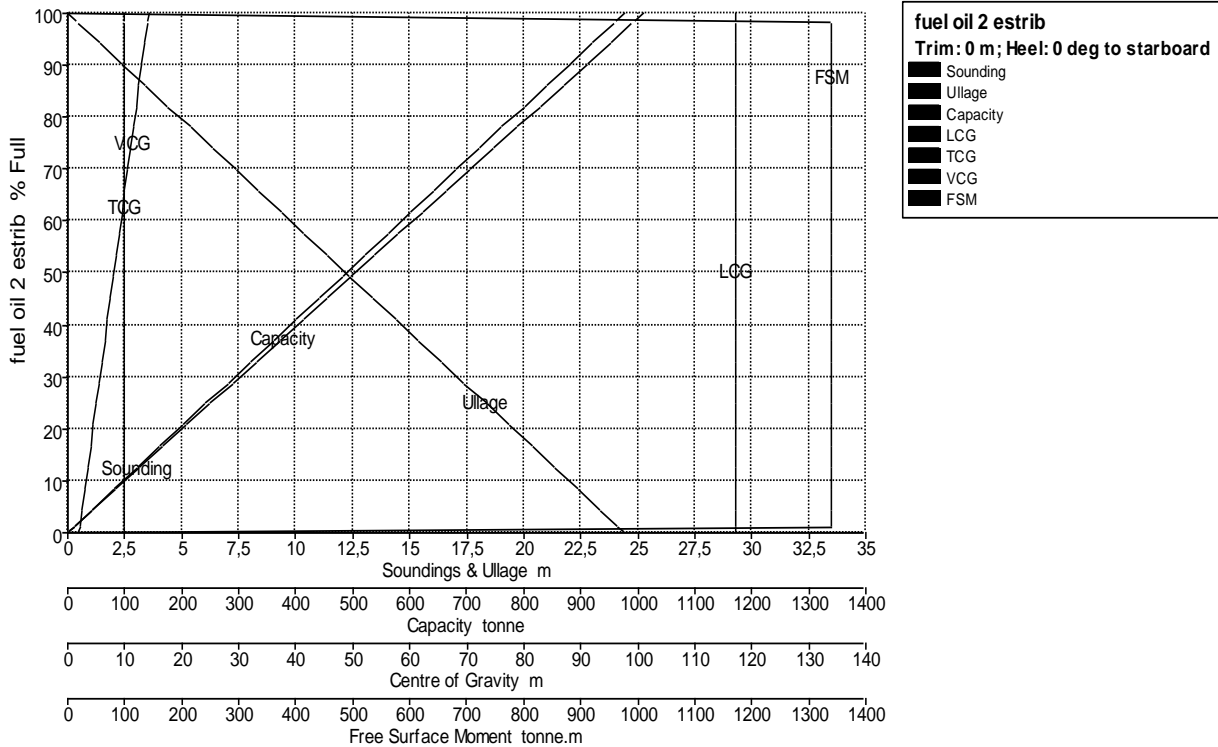

Tank Name	Sounding m	Ullage m	% Full	Capacity m ³	Capacity tonne	LCG m	TCG m	VCG m	FSM tonne.m
fuel oil 2 estrib	24,410	0,000	100,000	1068,902	1009,364	117,150	9,863	14,205	0,000
	24,000	0,410	98,320	1050,949	992,411	117,150	9,863	14,000	1340,704
	23,922	0,488	98,000	1047,524	989,177	117,150	9,863	13,961	1340,704
	23,897	0,513	97,900	1046,455	988,168	117,150	9,863	13,949	1340,704
	23,000	1,410	94,224	1007,159	951,060	117,150	9,863	13,500	1340,704
	22,000	2,410	90,127	963,370	909,710	117,150	9,863	13,000	1340,704
	21,000	3,410	86,030	919,580	868,359	117,150	9,863	12,500	1340,704
	20,000	4,410	81,934	875,790	827,009	117,150	9,863	12,000	1340,704
	19,000	5,410	77,837	832,001	785,659	117,150	9,863	11,500	1340,704
	18,000	6,410	73,740	788,211	744,308	117,150	9,863	11,000	1340,704
	17,000	7,410	69,644	744,422	702,958	117,150	9,863	10,500	1340,704
	16,000	8,410	65,547	700,632	661,607	117,150	9,863	10,000	1340,704
	15,000	9,410	61,450	656,843	620,257	117,150	9,863	9,500	1340,704
	14,000	10,410	57,354	613,053	578,906	117,150	9,863	9,000	1340,704

	13,000	11,410	53,257	569,264	537,556	117,150	9,863	8,500	1340,704
	12,000	12,410	49,160	525,474	496,205	117,150	9,863	8,000	1340,704
	11,000	13,410	45,063	481,685	454,855	117,150	9,863	7,500	1340,704
	10,000	14,410	40,967	437,895	413,504	117,150	9,863	7,000	1340,704
	9,000	15,410	36,870	394,106	372,154	117,150	9,863	6,500	1340,704
	8,000	16,410	32,773	350,316	330,804	117,150	9,863	6,000	1340,704
	7,000	17,410	28,677	306,527	289,453	117,150	9,863	5,500	1340,704
	6,000	18,410	24,580	262,737	248,103	117,150	9,863	5,000	1340,704
	5,000	19,410	20,483	218,948	206,752	117,150	9,863	4,500	1340,704
	4,000	20,410	16,387	175,158	165,402	117,150	9,863	4,000	1340,704
	3,000	21,410	12,290	131,369	124,051	117,150	9,863	3,500	1340,704
	2,000	22,410	8,193	87,579	82,701	117,150	9,863	3,000	1340,704
	1,000	23,410	4,097	43,790	41,350	117,150	9,863	2,500	1340,704
	0,244	24,166	1,000	10,689	10,094	117,150	9,863	2,122	1340,704
	0,000	24,410	0,000	0,000	0,000	117,150	9,863	2,000	0,000

Tank Calibrations - cofferdam 7 bab

Fluid Type = Specific gravity = 1

Permeability = 100 %

Trim = 0 m (+ve by stern); Heel = 0 deg to starboard

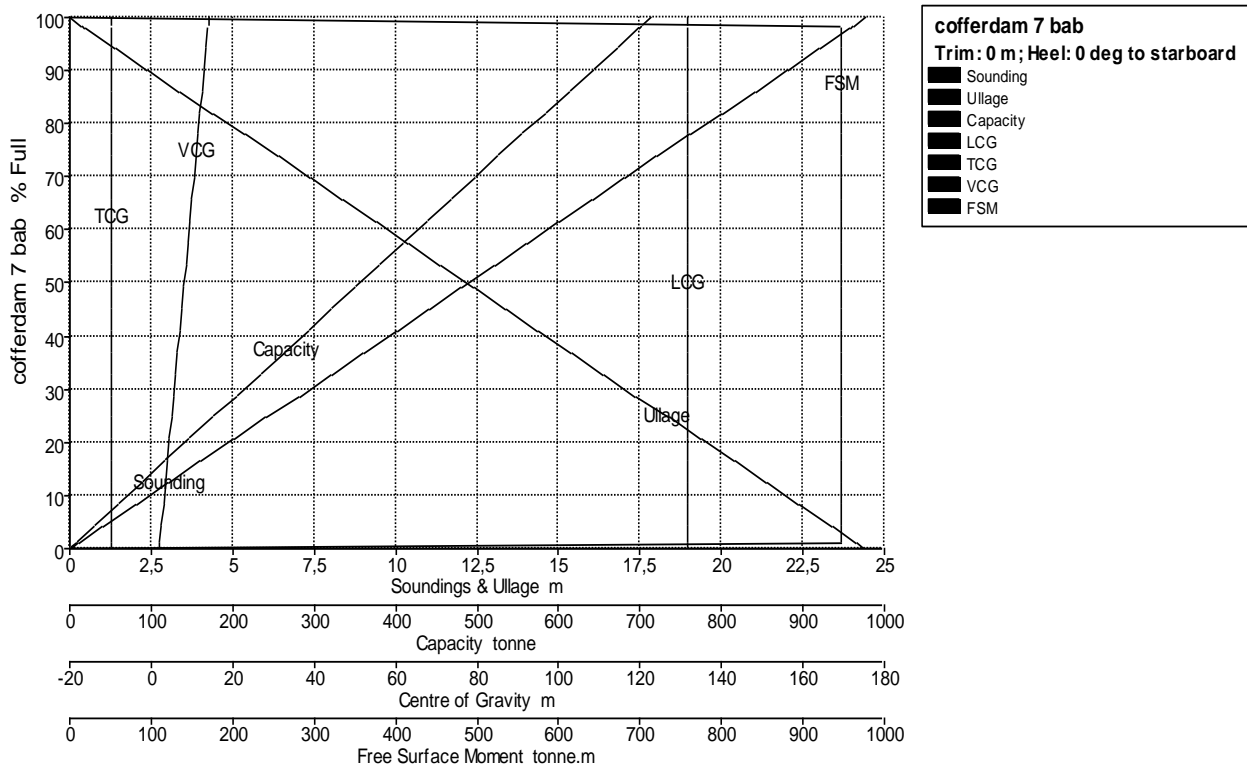

Tank Name	Sounding m	Ullage m	% Full	Capacity m³	Capacity tonne	LCG m	TCG m	VCG m	FSM tonne.m
cofferdam 7 bab	24,410	0,000	100,000	712,606	712,606	131,580	-9,863	14,205	0,000
	24,000	0,410	98,320	700,637	700,637	131,580	-9,863	14,000	946,531
	23,922	0,488	98,000	698,354	698,354	131,580	-9,863	13,961	946,531
	23,897	0,513	97,900	697,642	697,642	131,580	-9,863	13,949	946,531
	23,000	1,410	94,224	671,444	671,444	131,580	-9,863	13,500	946,531
	22,000	2,410	90,127	642,251	642,251	131,580	-9,863	13,000	946,531
	21,000	3,410	86,030	613,058	613,058	131,580	-9,863	12,500	946,531
	20,000	4,410	81,934	583,864	583,864	131,580	-9,863	12,000	946,531
	19,000	5,410	77,837	554,671	554,671	131,580	-9,863	11,500	946,531
	18,000	6,410	73,740	525,478	525,478	131,580	-9,863	11,000	946,531
	17,000	7,410	69,644	496,285	496,285	131,580	-9,863	10,500	946,531
	16,000	8,410	65,547	467,091	467,091	131,580	-9,863	10,000	946,531
	15,000	9,410	61,450	437,898	437,898	131,580	-9,863	9,500	946,531
	14,000	10,410	57,354	408,705	408,705	131,580	-9,863	9,000	946,531
	13,000	11,410	53,257	379,512	379,512	131,580	-9,863	8,500	946,531
	12,000	12,410	49,160	350,319	350,319	131,580	-9,863	8,000	946,531
	11,000	13,410	45,063	321,125	321,125	131,580	-9,863	7,500	946,531
	10,000	14,410	40,967	291,932	291,932	131,580	-9,863	7,000	946,531
	9,000	15,410	36,870	262,739	262,739	131,580	-9,863	6,500	946,531
	8,000	16,410	32,773	233,546	233,546	131,580	-9,863	6,000	946,531
	7,000	17,410	28,677	204,353	204,353	131,580	-9,863	5,500	946,531
	6,000	18,410	24,580	175,159	175,159	131,580	-9,863	5,000	946,531
	5,000	19,410	20,483	145,966	145,966	131,580	-9,863	4,500	946,531
	4,000	20,410	16,387	116,773	116,773	131,580	-9,863	4,000	946,531
	3,000	21,410	12,290	87,580	87,580	131,580	-9,863	3,500	946,531
	2,000	22,410	8,193	58,386	58,386	131,580	-9,863	3,000	946,531
	1,000	23,410	4,097	29,193	29,193	131,580	-9,863	2,500	946,531
	0,244	24,166	1,000	7,126	7,126	131,580	-9,863	2,122	946,531
	0,000	24,410	0,000	0,000	0,000	131,580	-9,863	2,000	0,000

Tank Calibrations - cofferdam 7 estrib

Fluid Type = Specific gravity = 1

Permeability = 100 %

Trim = 0 m (+ve by stern); Heel = 0 deg to starboard

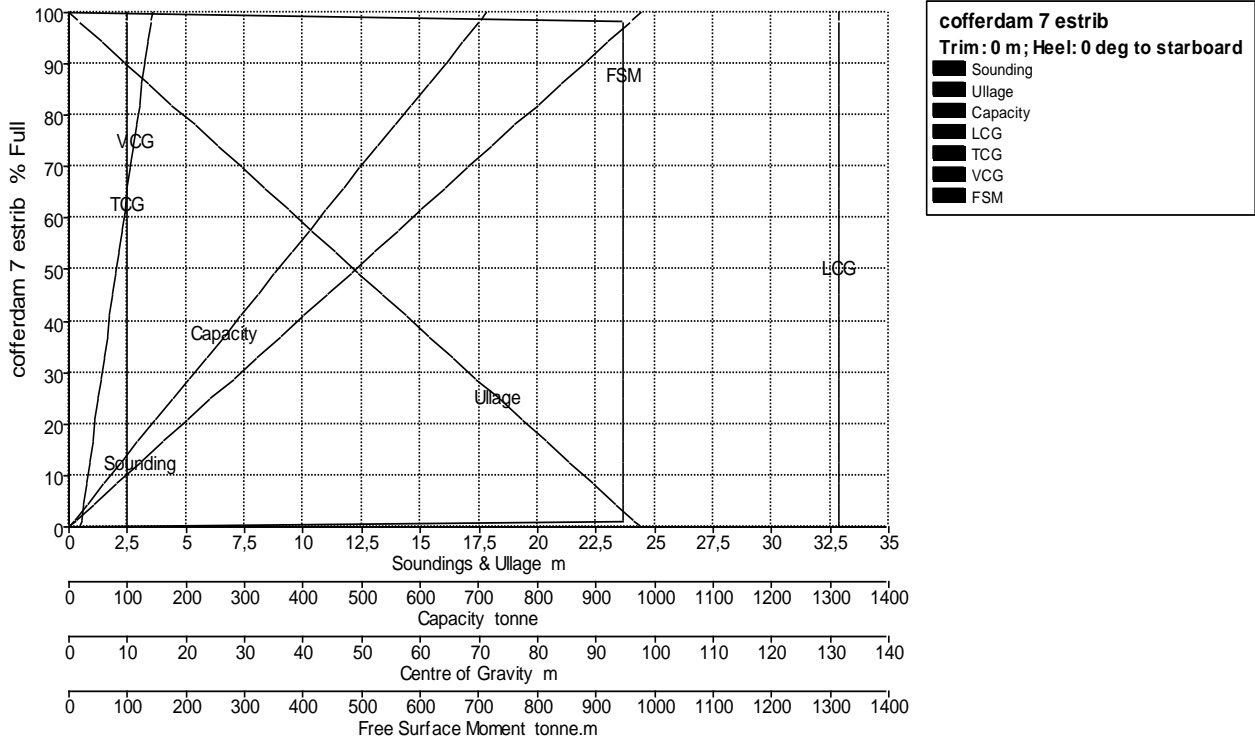

Tank Name	Sounding m	Ullage m	% Full	Capacity m ³	Capacity tonne	LCG m	TCG m	VCG m	FSM tonne.m
cofferdam 7 estrib	24,410	0,000	100,000	712,606	712,606	131,580	9,863	14,205	0,000
	24,000	0,410	98,320	700,637	700,637	131,580	9,863	14,000	946,531
	23,922	0,488	98,000	698,354	698,354	131,580	9,863	13,961	946,531
	23,897	0,513	97,900	697,642	697,642	131,580	9,863	13,949	946,531
	23,000	1,410	94,224	671,444	671,444	131,580	9,863	13,500	946,531
	22,000	2,410	90,127	642,251	642,251	131,580	9,863	13,000	946,531
	21,000	3,410	86,030	613,058	613,058	131,580	9,863	12,500	946,531
	20,000	4,410	81,934	583,864	583,864	131,580	9,863	12,000	946,531
	19,000	5,410	77,837	554,671	554,671	131,580	9,863	11,500	946,531
	18,000	6,410	73,740	525,478	525,478	131,580	9,863	11,000	946,531
	17,000	7,410	69,644	496,285	496,285	131,580	9,863	10,500	946,531

	16,000	8,410	65,547	467,091	467,091	131,580	9,863	10,000	946,531
	15,000	9,410	61,450	437,898	437,898	131,580	9,863	9,500	946,531
	14,000	10,410	57,354	408,705	408,705	131,580	9,863	9,000	946,531
	13,000	11,410	53,257	379,512	379,512	131,580	9,863	8,500	946,531
	12,000	12,410	49,160	350,319	350,319	131,580	9,863	8,000	946,531
	11,000	13,410	45,063	321,125	321,125	131,580	9,863	7,500	946,531
	10,000	14,410	40,967	291,932	291,932	131,580	9,863	7,000	946,531
	9,000	15,410	36,870	262,739	262,739	131,580	9,863	6,500	946,531
	8,000	16,410	32,773	233,546	233,546	131,580	9,863	6,000	946,531
	7,000	17,410	28,677	204,353	204,353	131,580	9,863	5,500	946,531
	6,000	18,410	24,580	175,159	175,159	131,580	9,863	5,000	946,531
	5,000	19,410	20,483	145,966	145,966	131,580	9,863	4,500	946,531
	4,000	20,410	16,387	116,773	116,773	131,580	9,863	4,000	946,531
	3,000	21,410	12,290	87,580	87,580	131,580	9,863	3,500	946,531
	2,000	22,410	8,193	58,386	58,386	131,580	9,863	3,000	946,531
	1,000	23,410	4,097	29,193	29,193	131,580	9,863	2,500	946,531
	0,244	24,166	1,000	7,126	7,126	131,580	9,863	2,122	946,531
	0,000	24,410	0,000	0,000	0,000	131,580	9,863	2,000	0,000

Tank Calibrations - fuel oil 3 bab

Fluid Type = Fuel Oil Specific gravity = 0,9443

Permeability = 100 %

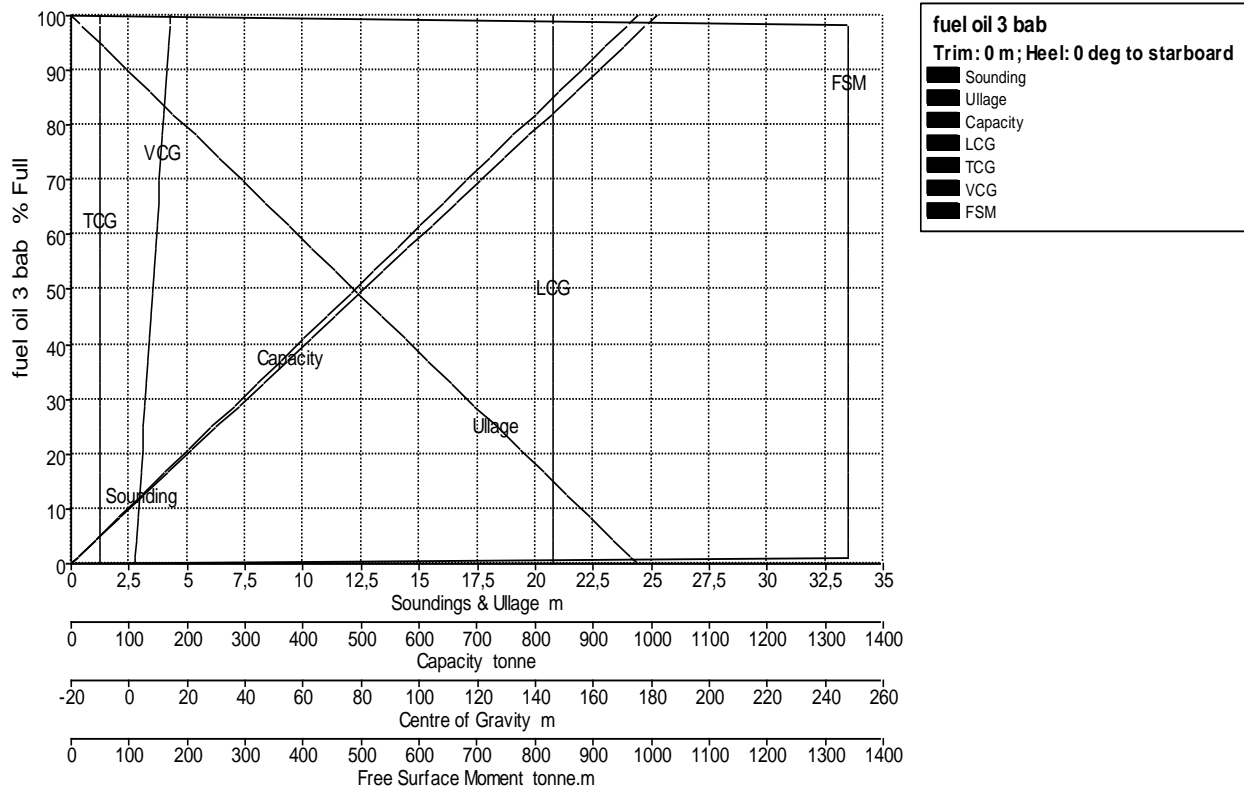

Trim = 0 m (+ve by stern); Heel = 0 deg to starboard

Tank Name	Sounding m	Ullage m	% Full	Capacity m ³	Capacity tonne	LCG m	TCG m	VCG m	FSM tonne.m
fuel oil 3 bab	24,410	0,000	100,000	1068,902	1009,364	146,010	-9,863	14,205	0,000
	24,000	0,410	98,320	1050,949	992,411	146,010	-9,863	14,000	1340,704
	23,922	0,488	98,000	1047,524	989,177	146,010	-9,863	13,961	1340,704
	23,897	0,513	97,900	1046,455	988,168	146,010	-9,863	13,949	1340,704
	23,000	1,410	94,224	1007,159	951,060	146,010	-9,863	13,500	1340,704
	22,000	2,410	90,127	963,370	909,710	146,010	-9,863	13,000	1340,704
	21,000	3,410	86,030	919,580	868,359	146,010	-9,863	12,500	1340,704
	20,000	4,410	81,934	875,790	827,009	146,010	-9,863	12,000	1340,704
	19,000	5,410	77,837	832,001	785,659	146,010	-9,863	11,500	1340,704
	18,000	6,410	73,740	788,211	744,308	146,010	-9,863	11,000	1340,704
	17,000	7,410	69,644	744,422	702,958	146,010	-9,863	10,500	1340,704
	16,000	8,410	65,547	700,632	661,607	146,010	-9,863	10,000	1340,704
	15,000	9,410	61,450	656,843	620,257	146,010	-9,863	9,500	1340,704
	14,000	10,410	57,354	613,053	578,906	146,010	-9,863	9,000	1340,704
	13,000	11,410	53,257	569,264	537,556	146,010	-9,863	8,500	1340,704
	12,000	12,410	49,160	525,474	496,205	146,010	-9,863	8,000	1340,704
	11,000	13,410	45,063	481,685	454,855	146,010	-9,863	7,500	1340,704
	10,000	14,410	40,967	437,895	413,504	146,010	-9,863	7,000	1340,704
	9,000	15,410	36,870	394,106	372,154	146,010	-9,863	6,500	1340,704
	8,000	16,410	32,773	350,316	330,804	146,010	-9,863	6,000	1340,704
	7,000	17,410	28,677	306,527	289,453	146,010	-9,863	5,500	1340,704
	6,000	18,410	24,580	262,737	248,103	146,010	-9,863	5,000	1340,704
	5,000	19,410	20,483	218,948	206,752	146,010	-9,863	4,500	1340,704
	4,000	20,410	16,387	175,158	165,402	146,010	-9,863	4,000	1340,704
	3,000	21,410	12,290	131,369	124,051	146,010	-9,863	3,500	1340,704
	2,000	22,410	8,193	87,579	82,701	146,010	-9,863	3,000	1340,704
	1,000	23,410	4,097	43,790	41,350	146,010	-9,863	2,500	1340,704
	0,244	24,166	1,000	10,689	10,094	146,010	-9,863	2,122	1340,704
	0,000	24,410	0,000	0,000	0,000	146,010	-9,863	2,000	0,000

Tank Calibrations - fuel oil 3 estrib

Fluid Type = Fuel Oil Specific gravity = 0,9443

Permeability = 100 %

Trim = 0 m (+ve by stern); Heel = 0 deg to starboard

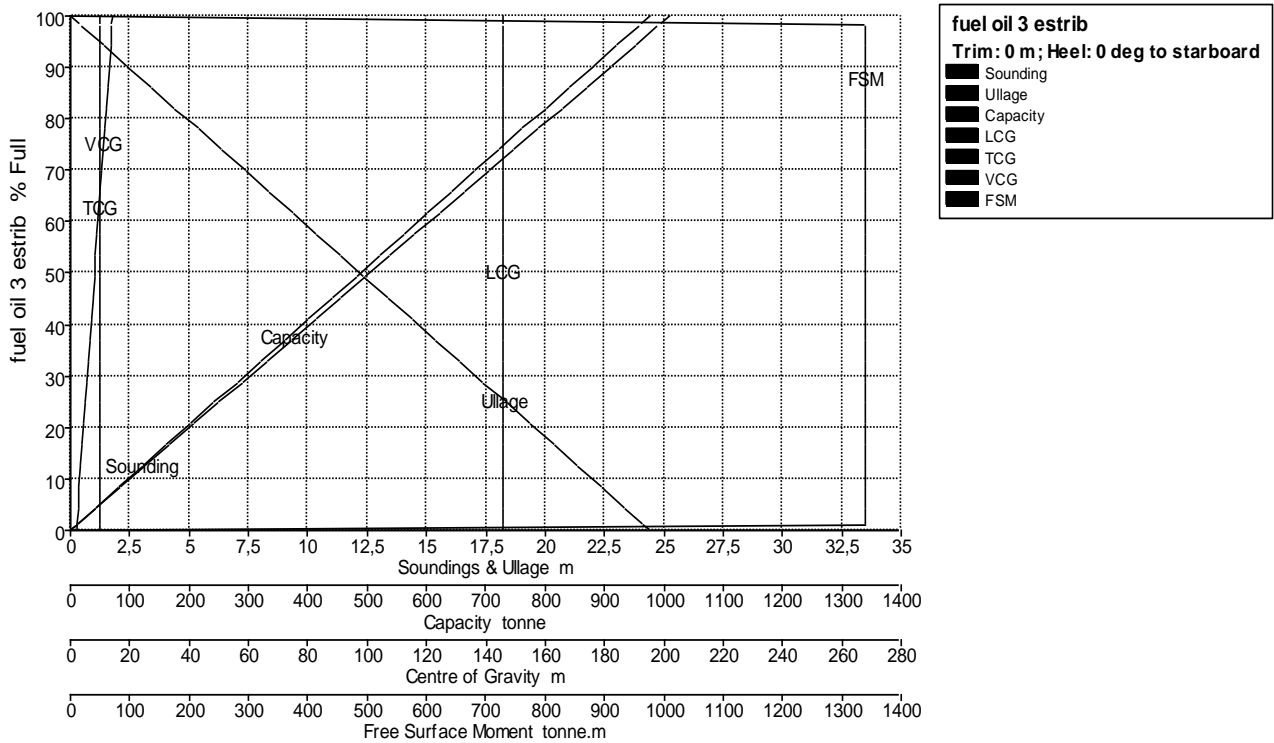

Tank Name	Sounding m	Ullage m	% Full	Capacity m ³	Capacity tonne	LCG m	TCG m	VCG m	FSM tonne.m
fuel oil 3 estrib	24,410	0,000	100,000	1068,902	1009,364	146,010	9,863	14,205	0,000
	24,000	0,410	98,320	1050,949	992,411	146,010	9,863	14,000	1340,704
	23,922	0,488	98,000	1047,524	989,177	146,010	9,863	13,961	1340,704
	23,897	0,513	97,900	1046,455	988,168	146,010	9,863	13,949	1340,704
	23,000	1,410	94,224	1007,159	951,060	146,010	9,863	13,500	1340,704
	22,000	2,410	90,127	963,370	909,710	146,010	9,863	13,000	1340,704
	21,000	3,410	86,030	919,580	868,359	146,010	9,863	12,500	1340,704
	20,000	4,410	81,934	875,790	827,009	146,010	9,863	12,000	1340,704
	19,000	5,410	77,837	832,001	785,659	146,010	9,863	11,500	1340,704
	18,000	6,410	73,740	788,211	744,308	146,010	9,863	11,000	1340,704
	17,000	7,410	69,644	744,422	702,958	146,010	9,863	10,500	1340,704

	16,000	8,410	65,547	700,632	661,607	146,010	9,863	10,000	1340,704
	15,000	9,410	61,450	656,843	620,257	146,010	9,863	9,500	1340,704
	14,000	10,410	57,354	613,053	578,906	146,010	9,863	9,000	1340,704
	13,000	11,410	53,257	569,264	537,556	146,010	9,863	8,500	1340,704
	12,000	12,410	49,160	525,474	496,205	146,010	9,863	8,000	1340,704
	11,000	13,410	45,063	481,685	454,855	146,010	9,863	7,500	1340,704
	10,000	14,410	40,967	437,895	413,504	146,010	9,863	7,000	1340,704
	9,000	15,410	36,870	394,106	372,154	146,010	9,863	6,500	1340,704
	8,000	16,410	32,773	350,316	330,804	146,010	9,863	6,000	1340,704
	7,000	17,410	28,677	306,527	289,453	146,010	9,863	5,500	1340,704
	6,000	18,410	24,580	262,737	248,103	146,010	9,863	5,000	1340,704
	5,000	19,410	20,483	218,948	206,752	146,010	9,863	4,500	1340,704
	4,000	20,410	16,387	175,158	165,402	146,010	9,863	4,000	1340,704
	3,000	21,410	12,290	131,369	124,051	146,010	9,863	3,500	1340,704
	2,000	22,410	8,193	87,579	82,701	146,010	9,863	3,000	1340,704
	1,000	23,410	4,097	43,790	41,350	146,010	9,863	2,500	1340,704
	0,244	24,166	1,000	10,689	10,094	146,010	9,863	2,122	1340,704
	0,000	24,410	0,000	0,000	0,000	146,010	9,863	2,000	0,000

Tank Calibrations - cofferdam 9 bab

Fluid Type = Specific gravity = 1

Permeability = 100 %

Trim = 0 m (+ve by stern); Heel = 0 deg to starboard

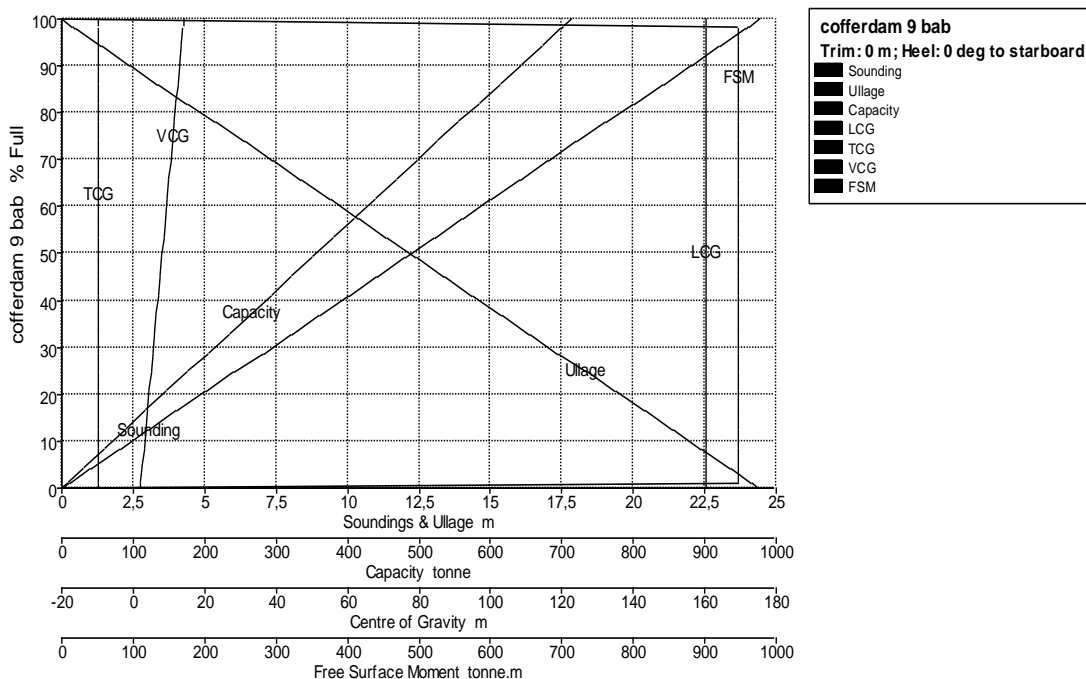

Tank Name	Sounding m	Ullage m	% Full	Capacity m³	Capacity tonne	LCG m	TCG m	VCG m	FSM tonne.m
cofferdam 9 bab	24,410	0,000	100,000	712,599	712,599	160,440	-9,863	14,205	0,000
	24,000	0,410	98,320	700,630	700,630	160,440	-9,863	14,000	946,521
	23,922	0,488	98,000	698,347	698,347	160,440	-9,863	13,961	946,521
	23,897	0,513	97,900	697,635	697,635	160,440	-9,863	13,949	946,521
	23,000	1,410	94,224	671,437	671,437	160,440	-9,863	13,500	946,521
	22,000	2,410	90,127	642,244	642,244	160,440	-9,863	13,000	946,521
	21,000	3,410	86,030	613,051	613,051	160,440	-9,863	12,500	946,521
	20,000	4,410	81,934	583,858	583,858	160,440	-9,863	12,000	946,521
	19,000	5,410	77,837	554,665	554,665	160,440	-9,863	11,500	946,521
	18,000	6,410	73,740	525,472	525,472	160,440	-9,863	11,000	946,521
	17,000	7,410	69,644	496,280	496,280	160,440	-9,863	10,500	946,521
	16,000	8,410	65,547	467,087	467,087	160,440	-9,863	10,000	946,521
	15,000	9,410	61,450	437,894	437,894	160,440	-9,863	9,500	946,521
	14,000	10,410	57,354	408,701	408,701	160,440	-9,863	9,000	946,521
	13,000	11,410	53,257	379,508	379,508	160,440	-9,863	8,500	946,521
	12,000	12,410	49,160	350,315	350,315	160,440	-9,863	8,000	946,521
	11,000	13,410	45,063	321,122	321,122	160,440	-9,863	7,500	946,521
	10,000	14,410	40,967	291,929	291,929	160,440	-9,863	7,000	946,521
	9,000	15,410	36,870	262,736	262,736	160,440	-9,863	6,500	946,521
	8,000	16,410	32,773	233,543	233,543	160,440	-9,863	6,000	946,521
	7,000	17,410	28,677	204,350	204,350	160,440	-9,863	5,500	946,521
	6,000	18,410	24,580	175,157	175,157	160,440	-9,863	5,000	946,521
	5,000	19,410	20,483	145,965	145,965	160,440	-9,863	4,500	946,521
	4,000	20,410	16,387	116,772	116,772	160,440	-9,863	4,000	946,521
	3,000	21,410	12,290	87,579	87,579	160,440	-9,863	3,500	946,521
	2,000	22,410	8,193	58,386	58,386	160,440	-9,863	3,000	946,521
	1,000	23,410	4,097	29,193	29,193	160,440	-9,863	2,500	946,521
	0,244	24,166	1,000	7,126	7,126	160,440	-9,863	2,122	946,521
	0,000	24,410	0,000	0,000	0,000	160,440	-9,863	2,000	0,000

Tank Calibrations - cofferdam 9 estrib

Fluid Type = Specific gravity = 1

Permeability = 100 %

Trim = 0 m (+ve by stern); Heel = 0 deg to starboard

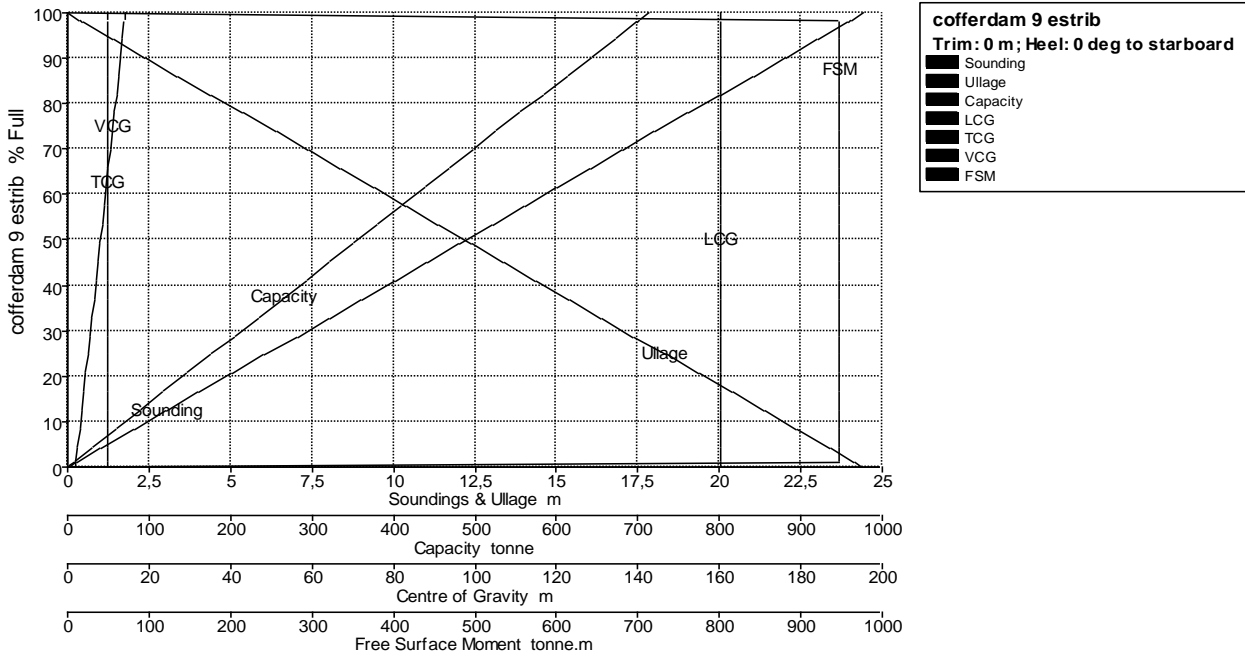

Tank Name	Sounding m	Ullage m	% Full	Capacity m³	Capacity tonne	LCG m	TCG m	VCG m	FSM tonne.m
cofferdam 9 estrib	24,410	0,000	100,000	712,599	712,599	160,440	9,863	14,205	0,000
	24,000	0,410	98,320	700,630	700,630	160,440	9,863	14,000	946,521
	23,922	0,488	98,000	698,347	698,347	160,440	9,863	13,961	946,521
	23,897	0,513	97,900	697,635	697,635	160,440	9,863	13,949	946,521
	23,000	1,410	94,224	671,437	671,437	160,440	9,863	13,500	946,521
	22,000	2,410	90,127	642,244	642,244	160,440	9,863	13,000	946,521
	21,000	3,410	86,030	613,051	613,051	160,440	9,863	12,500	946,521
	20,000	4,410	81,934	583,858	583,858	160,440	9,863	12,000	946,521
	19,000	5,410	77,837	554,665	554,665	160,440	9,863	11,500	946,521
	18,000	6,410	73,740	525,472	525,472	160,440	9,863	11,000	946,521
	17,000	7,410	69,644	496,280	496,280	160,440	9,863	10,500	946,521
	16,000	8,410	65,547	467,087	467,087	160,440	9,863	10,000	946,521
	15,000	9,410	61,450	437,894	437,894	160,440	9,863	9,500	946,521
	14,000	10,410	57,354	408,701	408,701	160,440	9,863	9,000	946,521
	13,000	11,410	53,257	379,508	379,508	160,440	9,863	8,500	946,521
	12,000	12,410	49,160	350,315	350,315	160,440	9,863	8,000	946,521
	11,000	13,410	45,063	321,122	321,122	160,440	9,863	7,500	946,521
	10,000	14,410	40,967	291,929	291,929	160,440	9,863	7,000	946,521
	9,000	15,410	36,870	262,736	262,736	160,440	9,863	6,500	946,521
	8,000	16,410	32,773	233,543	233,543	160,440	9,863	6,000	946,521
	7,000	17,410	28,677	204,350	204,350	160,440	9,863	5,500	946,521
	6,000	18,410	24,580	175,157	175,157	160,440	9,863	5,000	946,521
	5,000	19,410	20,483	145,965	145,965	160,440	9,863	4,500	946,521
	4,000	20,410	16,387	116,772	116,772	160,440	9,863	4,000	946,521
	3,000	21,410	12,290	87,579	87,579	160,440	9,863	3,500	946,521
	2,000	22,410	8,193	58,386	58,386	160,440	9,863	3,000	946,521
	1,000	23,410	4,097	29,193	29,193	160,440	9,863	2,500	946,521
	0,244	24,166	1,000	7,126	7,126	160,440	9,863	2,122	946,521
	0,000	24,410	0,000	0,000	0,000	160,440	9,863	2,000	0,000

Tank Calibrations - fuel oil 4 bab

Fluid Type = Fuel Oil Specific gravity = 0,9443

Permeability = 100 %

Trim = 0 m (+ve by stern); Heel = 0 deg to starboard

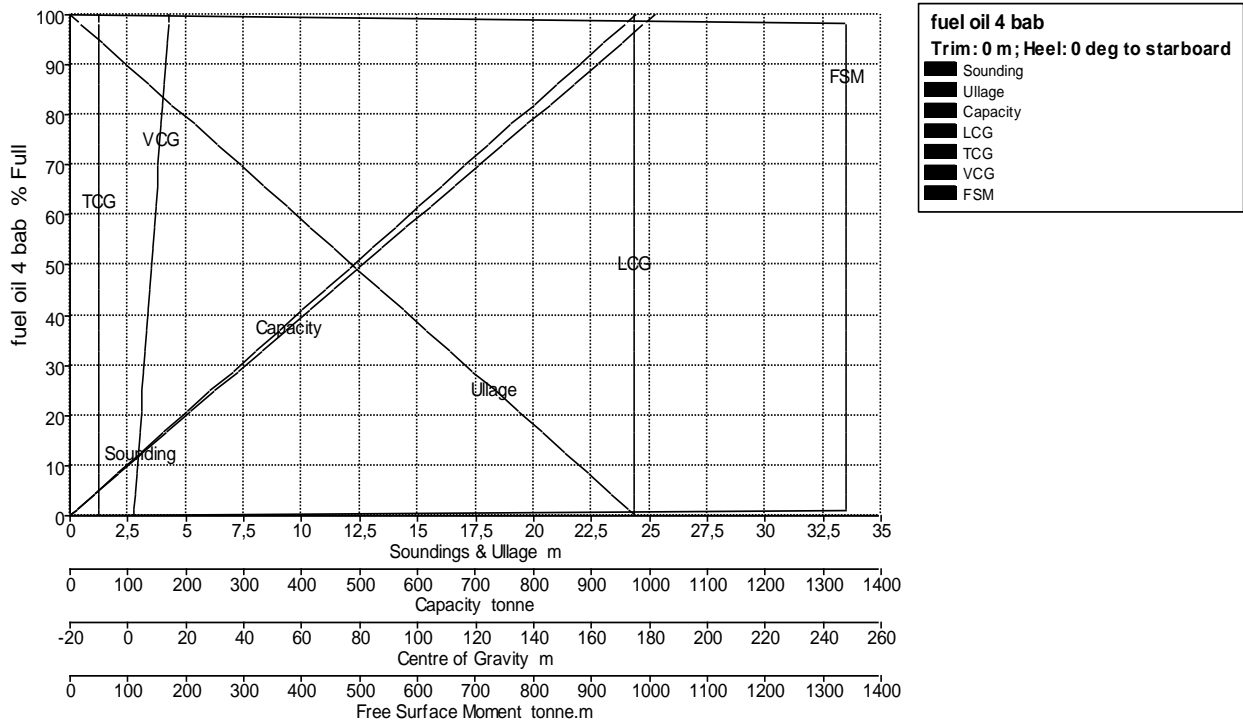

Tank Name	Sounding m	Ullage m	% Full	Capacity m ³	Capacity tonne	LCG m	TCG m	VCG m	FSM tonne.m
fuel oil 4 bab	24,410	0,000	100,000	1068,902	1009,364	174,870	-9,863	14,205	0,000
	24,000	0,410	98,320	1050,949	992,411	174,870	-9,863	14,000	1340,704
	23,922	0,488	98,000	1047,524	989,177	174,870	-9,863	13,961	1340,704
	23,897	0,513	97,900	1046,455	988,168	174,870	-9,863	13,949	1340,704
	23,000	1,410	94,224	1007,159	951,060	174,870	-9,863	13,500	1340,704
	22,000	2,410	90,127	963,370	909,710	174,870	-9,863	13,000	1340,704
	21,000	3,410	86,030	919,580	868,359	174,870	-9,863	12,500	1340,704
	20,000	4,410	81,934	875,790	827,009	174,870	-9,863	12,000	1340,704
	19,000	5,410	77,837	832,001	785,659	174,870	-9,863	11,500	1340,704
	18,000	6,410	73,740	788,211	744,308	174,870	-9,863	11,000	1340,704
	17,000	7,410	69,644	744,422	702,958	174,870	-9,863	10,500	1340,704
	16,000	8,410	65,547	700,632	661,607	174,870	-9,863	10,000	1340,704

	15,000	9,410	61,450	656,843	620,257	174,870	-9,863	9,500	1340,704
	14,000	10,410	57,354	613,053	578,906	174,870	-9,863	9,000	1340,704
	13,000	11,410	53,257	569,264	537,556	174,870	-9,863	8,500	1340,704
	12,000	12,410	49,160	525,474	496,205	174,870	-9,863	8,000	1340,704
	11,000	13,410	45,063	481,685	454,855	174,870	-9,863	7,500	1340,704
	10,000	14,410	40,967	437,895	413,504	174,870	-9,863	7,000	1340,704
	9,000	15,410	36,870	394,106	372,154	174,870	-9,863	6,500	1340,704
	8,000	16,410	32,773	350,316	330,804	174,870	-9,863	6,000	1340,704
	7,000	17,410	28,677	306,527	289,453	174,870	-9,863	5,500	1340,704
	6,000	18,410	24,580	262,737	248,103	174,870	-9,863	5,000	1340,704
	5,000	19,410	20,483	218,948	206,752	174,870	-9,863	4,500	1340,704
	4,000	20,410	16,387	175,158	165,402	174,870	-9,863	4,000	1340,704
	3,000	21,410	12,290	131,369	124,051	174,870	-9,863	3,500	1340,704
	2,000	22,410	8,193	87,579	82,701	174,870	-9,863	3,000	1340,704
	1,000	23,410	4,097	43,790	41,350	174,870	-9,863	2,500	1340,704
	0,244	24,166	1,000	10,689	10,094	174,870	-9,863	2,122	1340,704
	0,000	24,410	0,000	0,000	0,000	174,870	-9,863	2,000	0,000

Tank Calibrations - fuel oil 4 estrib

Fluid Type = Fuel Oil Specific gravity = 0,9443

Permeability = 100 %

Trim = 0 m (+ve by stern); Heel = 0 deg to starboard

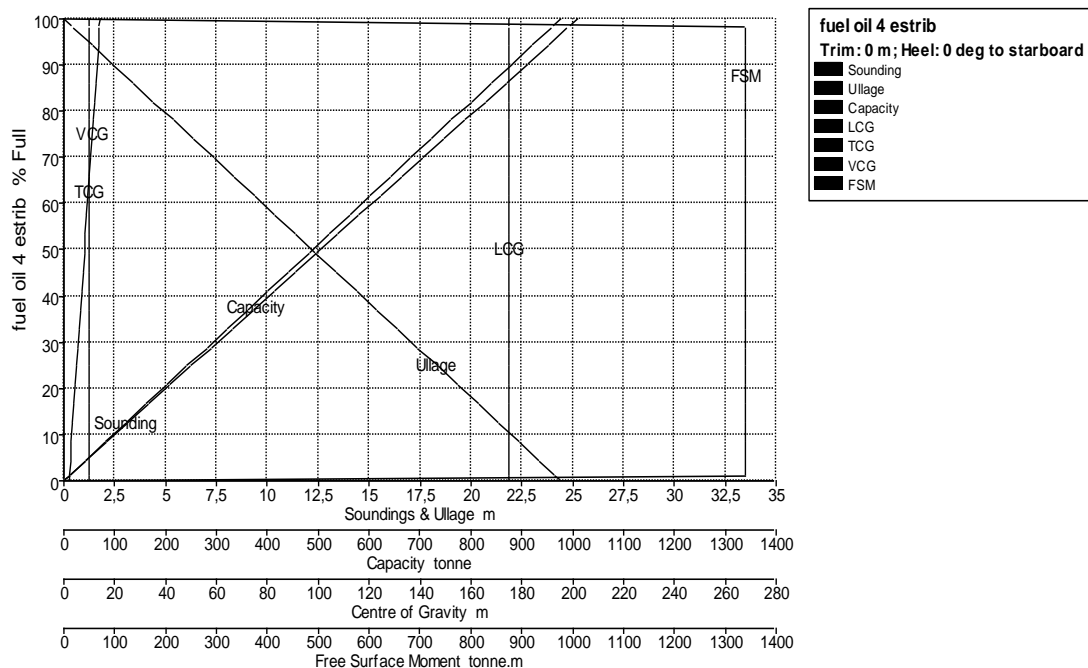

Tank Name	Sounding m	Ullage m	% Full	Capacity m³	Capacity tonne	LCG m	TCG m	VCG m	FSM tonne.m
fuel oil 4 estrib	24,410	0,000	100,000	1068,902	1009,364	174,870	9,863	14,205	0,000
	24,000	0,410	98,320	1050,949	992,411	174,870	9,863	14,000	1340,704
	23,922	0,488	98,000	1047,524	989,177	174,870	9,863	13,961	1340,704
	23,897	0,513	97,900	1046,455	988,168	174,870	9,863	13,949	1340,704
	23,000	1,410	94,224	1007,159	951,060	174,870	9,863	13,500	1340,704
	22,000	2,410	90,127	963,370	909,710	174,870	9,863	13,000	1340,704
	21,000	3,410	86,030	919,580	868,359	174,870	9,863	12,500	1340,704
	20,000	4,410	81,934	875,790	827,009	174,870	9,863	12,000	1340,704
	19,000	5,410	77,837	832,001	785,659	174,870	9,863	11,500	1340,704
	18,000	6,410	73,740	788,211	744,308	174,870	9,863	11,000	1340,704
	17,000	7,410	69,644	744,422	702,958	174,870	9,863	10,500	1340,704
	16,000	8,410	65,547	700,632	661,607	174,870	9,863	10,000	1340,704
	15,000	9,410	61,450	656,843	620,257	174,870	9,863	9,500	1340,704
	14,000	10,410	57,354	613,053	578,906	174,870	9,863	9,000	1340,704
	13,000	11,410	53,257	569,264	537,556	174,870	9,863	8,500	1340,704
	12,000	12,410	49,160	525,474	496,205	174,870	9,863	8,000	1340,704
	11,000	13,410	45,063	481,685	454,855	174,870	9,863	7,500	1340,704
	10,000	14,410	40,967	437,895	413,504	174,870	9,863	7,000	1340,704
	9,000	15,410	36,870	394,106	372,154	174,870	9,863	6,500	1340,704
	8,000	16,410	32,773	350,316	330,804	174,870	9,863	6,000	1340,704
	7,000	17,410	28,677	306,527	289,453	174,870	9,863	5,500	1340,704
	6,000	18,410	24,580	262,737	248,103	174,870	9,863	5,000	1340,704
	5,000	19,410	20,483	218,948	206,752	174,870	9,863	4,500	1340,704
	4,000	20,410	16,387	175,158	165,402	174,870	9,863	4,000	1340,704
	3,000	21,410	12,290	131,369	124,051	174,870	9,863	3,500	1340,704
	2,000	22,410	8,193	87,579	82,701	174,870	9,863	3,000	1340,704
	1,000	23,410	4,097	43,790	41,350	174,870	9,863	2,500	1340,704

	0,244	24,166	1,000	10,689	10,094	174,870	9,863	2,122	1340,704
	0,000	24,410	0,000	0,000	0,000	174,870	9,863	2,000	0,000

Tank Calibrations - diesel 1 bab

Fluid Type = Diesel Specific gravity = 0,84

Permeability = 100 %

Trim = 0 m (+ve by stern); Heel = 0 deg to starboard

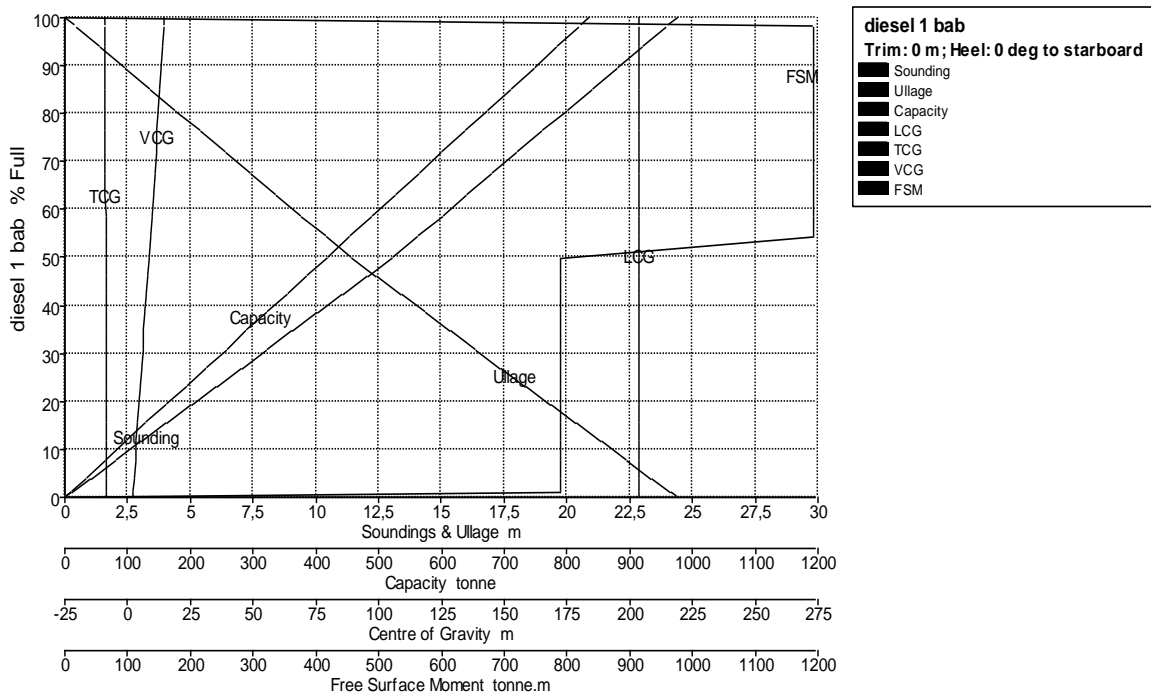

Tank Name	Sounding m	Ullage m	% Full	Capacity m ³	Capacity tonne	LCG m	TCG m	VCG m	FSM tonne.m
diesel 1 bab	24,410	0,000	100,000	994,188	835,118	203,730	-9,217	14,624	0,000
	24,000	0,410	98,194	976,234	820,037	203,730	-9,205	14,411	1192,621
	23,956	0,454	98,000	974,304	818,416	203,730	-9,204	14,388	1192,621
	23,933	0,477	97,900	973,310	817,581	203,730	-9,203	14,377	1192,621
	23,000	1,410	93,790	932,445	783,254	203,730	-9,174	13,891	1192,621
	22,000	2,410	89,385	888,655	746,471	203,730	-9,140	13,368	1192,621
	21,000	3,410	84,980	844,866	709,687	203,730	-9,103	12,843	1192,621
	20,000	4,410	80,576	801,076	672,904	203,730	-9,061	12,315	1192,621
	19,000	5,410	76,171	757,287	636,121	203,730	-9,015	11,784	1192,621

	18,000	6,410	71,767	713,497	599,338	203,730	-8,963	11,249	1192,621
	17,000	7,410	67,362	669,708	562,555	203,730	-8,904	10,709	1192,621
	16,000	8,410	62,958	625,918	525,771	203,730	-8,837	10,164	1192,621
	15,000	9,410	58,553	582,129	488,988	203,730	-8,760	9,612	1192,621
	14,000	10,410	54,149	538,339	452,205	203,730	-8,670	9,052	1192,621
	13,000	11,410	49,886	495,959	416,606	203,730	-8,592	8,500	788,678
	12,000	12,410	46,048	457,809	384,559	203,730	-8,592	8,000	788,678
	11,000	13,410	42,211	419,658	352,513	203,730	-8,592	7,500	788,678
	10,000	14,410	38,374	381,507	320,466	203,730	-8,592	7,000	788,678
	9,000	15,410	34,536	343,356	288,419	203,730	-8,592	6,500	788,678
	8,000	16,410	30,699	305,206	256,373	203,730	-8,592	6,000	788,678
	7,000	17,410	26,862	267,055	224,326	203,730	-8,592	5,500	788,678
	6,000	18,410	23,024	228,904	192,280	203,730	-8,592	5,000	788,678
	5,000	19,410	19,187	190,754	160,233	203,730	-8,592	4,500	788,678
	4,000	20,410	15,349	152,603	128,186	203,730	-8,592	4,000	788,678
	3,000	21,410	11,512	114,452	96,140	203,730	-8,592	3,500	788,678
	2,000	22,410	7,675	76,301	64,093	203,730	-8,592	3,000	788,678
	1,000	23,410	3,837	38,151	32,047	203,730	-8,592	2,500	788,678
	0,261	24,149	1,000	9,942	8,351	203,730	-8,592	2,130	788,678
	0,000	24,410	0,000	0,000	0,000	203,730	-8,592	2,000	0,000

Tank Calibrations - diesel 1 estrib

Fluid Type = Diesel Specific gravity = 0,84

Permeability = 100 %

Trim = 0 m (+ve by stern); Heel = 0 deg to starboard

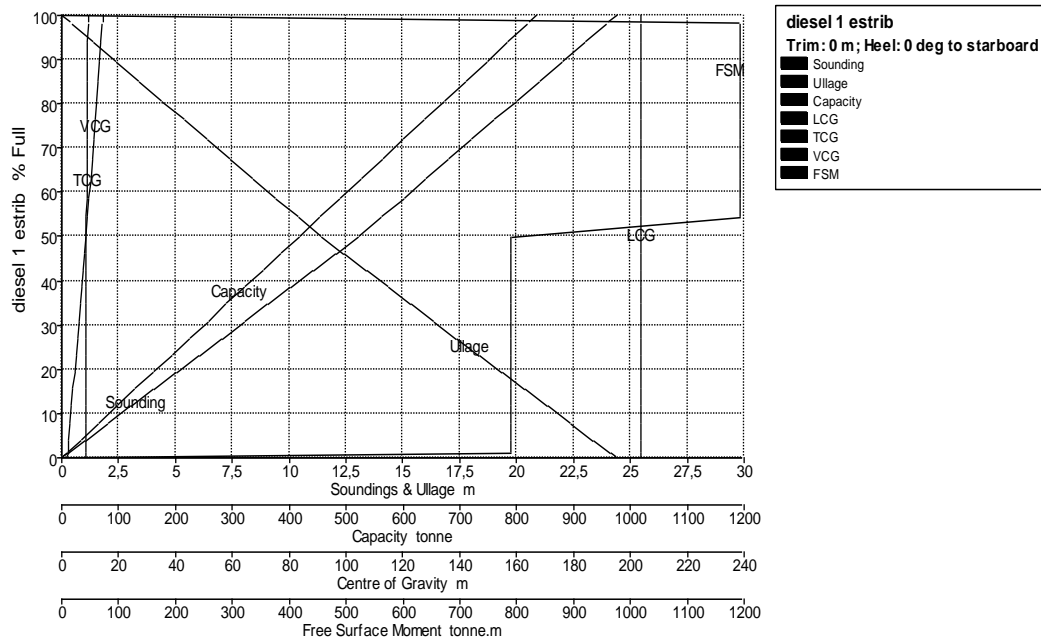

Tank Name	Sounding m	Ullage m	% Full	Capacity m ³	Capacity tonne	LCG m	TCG m	VCG m	FSM tonne.m
diesel 1 estrib	24,410	0,000	100,000	994,188	835,118	203,730	9,217	14,624	0,000
	24,000	0,410	98,194	976,234	820,037	203,730	9,205	14,411	1192,621
	23,956	0,454	98,000	974,304	818,416	203,730	9,204	14,388	1192,621
	23,933	0,477	97,900	973,310	817,581	203,730	9,203	14,377	1192,621
	23,000	1,410	93,790	932,445	783,254	203,730	9,174	13,891	1192,621
	22,000	2,410	89,385	888,655	746,471	203,730	9,140	13,368	1192,621
	21,000	3,410	84,980	844,866	709,687	203,730	9,103	12,843	1192,621
	20,000	4,410	80,576	801,076	672,904	203,730	9,061	12,315	1192,621
	19,000	5,410	76,171	757,287	636,121	203,730	9,015	11,784	1192,621
	18,000	6,410	71,767	713,497	599,338	203,730	8,963	11,249	1192,621
	17,000	7,410	67,362	669,708	562,555	203,730	8,904	10,709	1192,621
	16,000	8,410	62,958	625,918	525,771	203,730	8,837	10,164	1192,621
	15,000	9,410	58,553	582,129	488,988	203,730	8,760	9,612	1192,621
	14,000	10,410	54,149	538,339	452,205	203,730	8,670	9,052	1192,621
	13,000	11,410	49,886	495,959	416,606	203,730	8,592	8,500	788,678
	12,000	12,410	46,048	457,809	384,559	203,730	8,592	8,000	788,678

	11,000	13,410	42,211	419,658	352,513	203,730	8,592	7,500	788,678
	10,000	14,410	38,374	381,507	320,466	203,730	8,592	7,000	788,678
	9,000	15,410	34,536	343,356	288,419	203,730	8,592	6,500	788,678
	8,000	16,410	30,699	305,206	256,373	203,730	8,592	6,000	788,678
	7,000	17,410	26,862	267,055	224,326	203,730	8,592	5,500	788,678
	6,000	18,410	23,024	228,904	192,280	203,730	8,592	5,000	788,678
	5,000	19,410	19,187	190,754	160,233	203,730	8,592	4,500	788,678
	4,000	20,410	15,349	152,603	128,186	203,730	8,592	4,000	788,678
	3,000	21,410	11,512	114,452	96,140	203,730	8,592	3,500	788,678
	2,000	22,410	7,675	76,301	64,093	203,730	8,592	3,000	788,678
	1,000	23,410	3,837	38,151	32,047	203,730	8,592	2,500	788,678
	0,261	24,149	1,000	9,942	8,351	203,730	8,592	2,130	788,678
	0,000	24,410	0,000	0,000	0,000	203,730	8,592	2,000	0,000

Tank Calibrations - pique de proa

Fluid Type = Water Ballast Specific gravity = 1,025

Permeability = 100 %

Trim = 0 m (+ve by stern); Heel = 0 deg to starboard

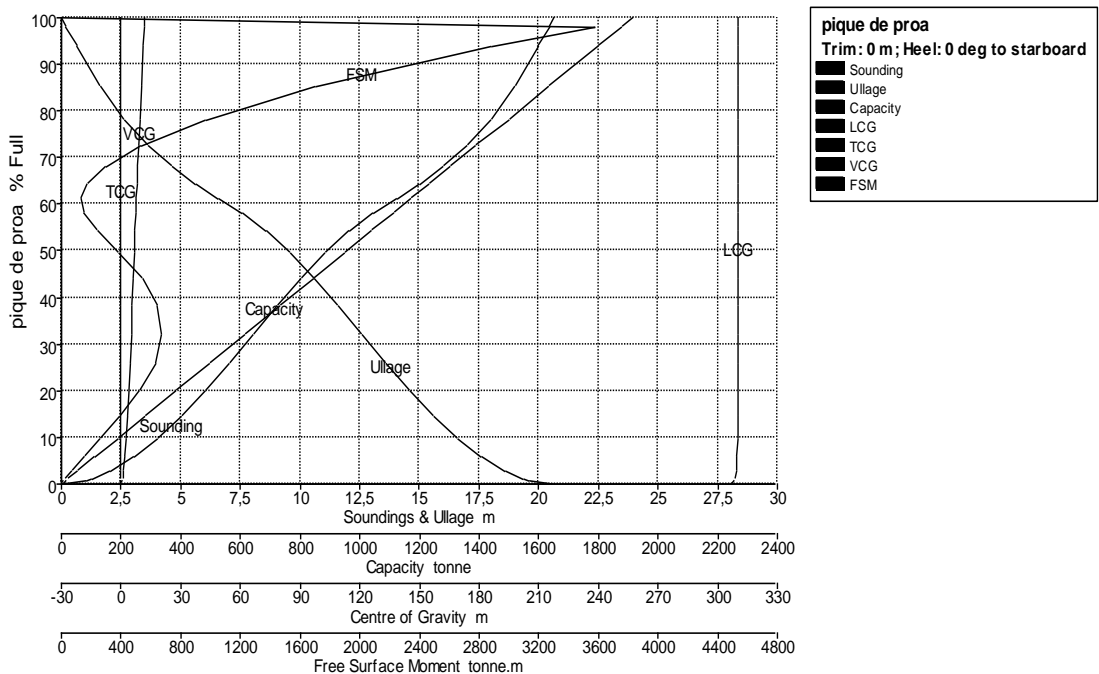

Tank Name	Sounding m	Ullage m	% Full	Capacity m ³	Capacity tonne	LCG m	TCG m	VCG m	FSM tonne.m
paque de proa	20,630	0,000	100,000	1868,681	1915,398	310,076	0,000	11,717	0,000
	20,436	0,194	98,000	1831,308	1877,090	310,079	0,000	11,537	3588,089
	20,426	0,204	97,900	1829,439	1875,175	310,079	0,000	11,528	3570,106
	20,000	0,630	93,754	1751,969	1795,769	310,087	0,000	11,144	2876,311
	19,000	1,630	85,209	1592,283	1632,090	310,112	0,000	10,304	1694,455
	18,000	2,630	78,169	1460,725	1497,243	310,147	0,000	9,565	965,414
	17,000	3,630	72,467	1354,184	1388,038	310,190	0,000	8,939	532,297
	16,000	4,630	67,908	1268,989	1300,714	310,243	0,000	8,430	287,749
	15,000	5,630	64,265	1200,915	1230,938	310,302	0,000	8,028	169,082
	14,000	6,630	61,157	1142,835	1171,406	310,364	0,000	7,699	129,274
	13,000	7,630	58,017	1084,161	1111,265	310,421	0,000	7,386	150,154
	12,000	8,630	54,229	1013,371	1038,705	310,458	0,000	7,030	241,608
	11,000	9,630	49,541	925,756	948,900	310,466	0,000	6,608	390,599
	10,000	10,630	44,091	823,927	844,525	310,452	0,000	6,129	544,258
	9,000	11,630	38,138	712,680	730,497	310,422	0,000	5,603	645,143
	8,000	12,630	31,954	597,114	612,042	310,375	0,000	5,043	672,099
	7,000	13,630	25,810	482,313	494,371	310,307	0,000	4,457	630,947
	6,000	14,630	19,942	372,647	381,963	310,217	0,000	3,855	523,097
	5,000	15,630	14,536	271,622	278,413	310,095	0,000	3,239	389,638
	4,000	16,630	9,758	182,342	186,901	309,920	0,000	2,616	258,856
	3,000	17,630	5,743	107,323	110,006	309,649	0,000	1,986	146,468
	2,000	18,630	2,625	49,049	50,275	309,150	0,000	1,345	62,720
	1,249	19,381	1,000	18,687	19,154	308,434	0,000	0,848	21,862
	1,000	19,630	0,627	11,719	12,012	308,127	0,000	0,681	12,638
	0,000	20,630	0,000	0,000	0,000	306,124	0,000	0,000	0,000

Tank Calibrations - doble fondo 1 bab

Fluid Type = Water Ballast Specific gravity = 1,025

Permeability = 100 %

Trim = 0 m (+ve by stern); Heel = 0 deg to starboard

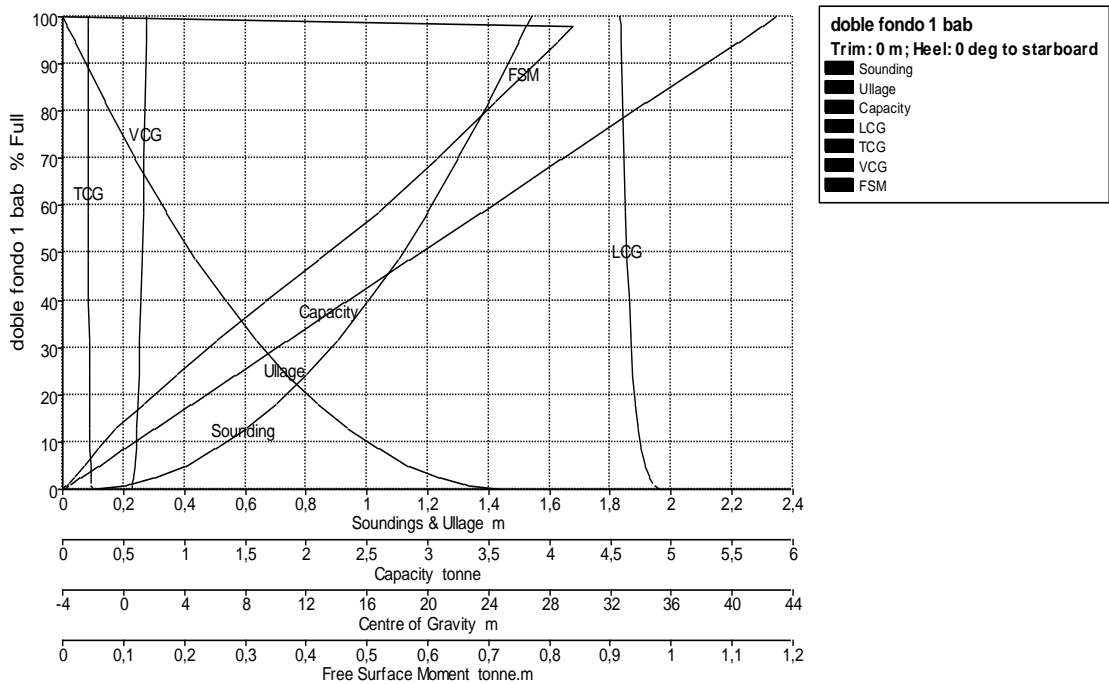

Tank Name	Sounding m	Ullage m	% Full	Capacity m ³	Capacity tonne	LCG m	TCG m	VCG m	FSM tonne.m
doble fondo 1 bab	1,540	0,000	100,000	5,718	5,861	32,643	-2,358	1,514	0,000
	1,525	0,015	98,000	5,604	5,744	32,657	-2,356	1,505	0,839
	1,524	0,015	97,900	5,598	5,738	32,657	-2,356	1,504	0,838
	1,500	0,040	94,616	5,410	5,546	32,680	-2,353	1,488	0,812
	1,400	0,140	81,703	4,672	4,789	32,780	-2,339	1,421	0,710
	1,300	0,240	69,656	3,983	4,083	32,889	-2,324	1,354	0,614
	1,200	0,340	58,528	3,347	3,430	33,003	-2,308	1,286	0,518
	1,100	0,440	48,437	2,770	2,839	33,114	-2,291	1,218	0,420
	1,000	0,540	39,382	2,252	2,308	33,222	-2,272	1,150	0,331
	0,900	0,640	31,290	1,789	1,834	33,345	-2,255	1,083	0,252
	0,800	0,740	24,163	1,382	1,416	33,488	-2,237	1,016	0,187
	0,700	0,840	18,002	1,029	1,055	33,647	-2,220	0,949	0,132
	0,600	0,940	12,805	0,732	0,751	33,813	-2,202	0,883	0,087
	0,500	1,040	8,480	0,485	0,497	34,002	-2,184	0,817	0,059
	0,400	1,140	4,941	0,283	0,290	34,298	-2,166	0,749	0,036
	0,300	1,240	2,386	0,136	0,140	34,585	-2,139	0,680	0,019

	0,220	1,320	1,000	0,057	0,059	34,887	-2,108	0,621	0,008
	0,200	1,340	0,769	0,044	0,045	34,960	-2,099	0,607	0,006
	0,100	1,440	0,109	0,006	0,006	35,323	-2,052	0,533	0,000
	0,000	1,540	0,000	0,000	0,000	35,722	-2,000	0,460	0,000

Tank Calibrations - doble fondo 1 estrib

Fluid Type = Water Ballast Specific gravity = 1,025

Permeability = 100 %

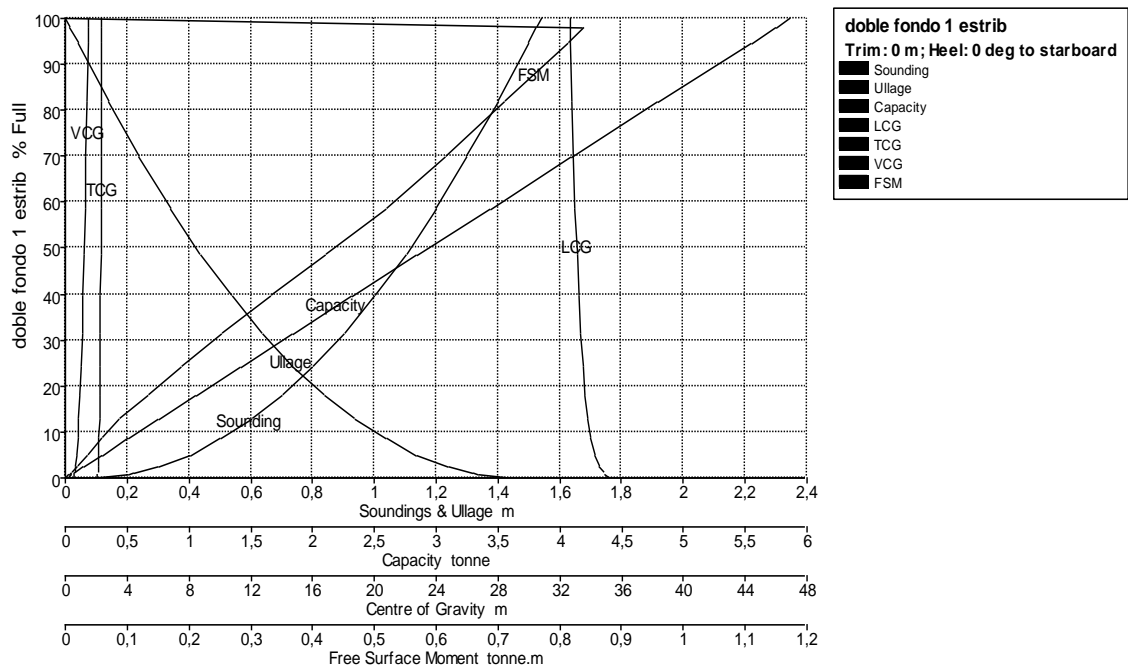

Trim = 0 m (+ve by stern); Heel = 0 deg to starboard

Tank Name	Sounding m	Ullage m	% Full	Capacity m ³	Capacity tonne	LCG m	TCG m	VCG m	FSM tonne.m
doble fondo 1 estrib	1,540	0,000	100,000	5,718	5,861	32,643	2,358	1,514	0,000
	1,525	0,015	98,000	5,604	5,744	32,657	2,356	1,505	0,839
	1,524	0,015	97,900	5,598	5,738	32,657	2,356	1,504	0,838
	1,500	0,040	94,616	5,410	5,546	32,680	2,353	1,488	0,812
	1,400	0,140	81,703	4,672	4,789	32,780	2,339	1,421	0,710
	1,300	0,240	69,656	3,983	4,083	32,889	2,324	1,354	0,614

	1,200	0,340	58,528	3,347	3,430	33,003	2,308	1,286	0,518
	1,100	0,440	48,437	2,770	2,839	33,114	2,291	1,218	0,420
	1,000	0,540	39,382	2,252	2,308	33,222	2,272	1,150	0,331
	0,900	0,640	31,290	1,789	1,834	33,345	2,255	1,083	0,252
	0,800	0,740	24,163	1,382	1,416	33,488	2,237	1,016	0,187
	0,700	0,840	18,002	1,029	1,055	33,647	2,220	0,949	0,132
	0,600	0,940	12,805	0,732	0,751	33,813	2,202	0,883	0,087
	0,500	1,040	8,480	0,485	0,497	34,002	2,184	0,817	0,059
	0,400	1,140	4,941	0,283	0,290	34,298	2,166	0,749	0,036
	0,300	1,240	2,386	0,136	0,140	34,585	2,139	0,680	0,019
	0,220	1,320	1,000	0,057	0,059	34,887	2,108	0,621	0,008
	0,200	1,340	0,769	0,044	0,045	34,960	2,099	0,607	0,006
	0,100	1,440	0,109	0,006	0,006	35,323	2,052	0,533	0,000
	0,000	1,540	0,000	0,000	0,000	35,722	2,000	0,460	0,000

Tank Calibrations - doble fondo 2 bab

Fluid Type = Water Ballast Specific gravity = 1,025

Permeability = 100 %

Trim = 0 m (+ve by stern); Heel = 0 deg to starboard

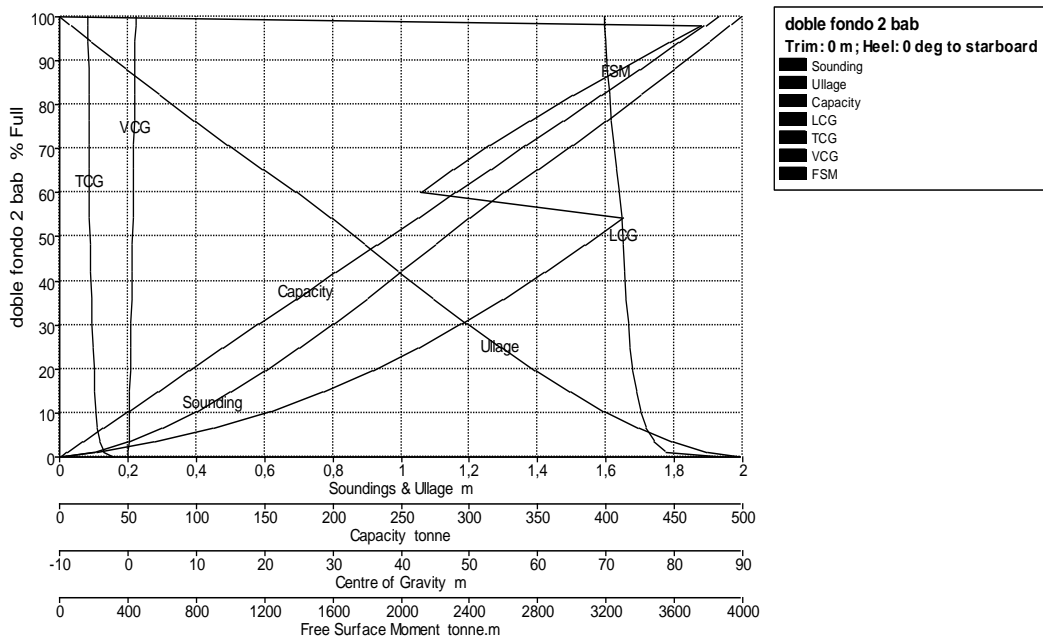

Tank Name	Sounding m	Ullage m	% Full	Capacity m ³	Capacity tonne	LCG m	TCG m	VCG m	FSM tonne.m
doble fondo 2 bab	1,996	0,000	100,000	470,257	482,014	69,765	-5,845	1,127	0,000
	1,964	0,032	98,000	460,852	472,374	69,832	-5,830	1,109	3760,399
	1,963	0,033	97,900	460,382	471,892	69,836	-5,830	1,108	3755,559
	1,900	0,096	94,027	442,169	453,223	69,974	-5,802	1,074	3566,760
	1,800	0,196	87,970	413,687	424,030	70,217	-5,762	1,020	3274,389
	1,700	0,296	82,083	386,000	395,650	70,489	-5,725	0,968	3000,616
	1,600	0,396	76,363	359,101	368,079	70,794	-5,693	0,916	2746,958
	1,500	0,496	70,812	332,997	341,322	71,138	-5,665	0,866	2515,094
	1,400	0,596	65,428	307,681	315,373	71,525	-5,643	0,818	2304,276
	1,300	0,696	60,217	283,173	290,252	71,963	-5,628	0,772	2110,124
	1,200	0,796	54,452	256,062	262,464	72,301	-5,587	0,721	3303,672
	1,100	0,896	48,032	225,875	231,522	72,485	-5,507	0,663	3069,761
	1,000	0,996	41,829	196,706	201,623	72,693	-5,422	0,605	2834,119
	0,900	1,096	35,861	168,637	172,853	72,932	-5,329	0,547	2595,572
	0,800	1,196	30,145	141,757	145,301	73,209	-5,227	0,488	2351,736
	0,700	1,296	24,707	116,186	119,090	73,537	-5,113	0,430	2096,233
	0,600	1,396	19,577	92,061	94,363	73,937	-4,984	0,371	1831,458
	0,500	1,496	14,799	69,596	71,336	74,441	-4,834	0,312	1542,898
	0,400	1,596	10,444	49,112	50,340	75,074	-4,654	0,252	1234,239
	0,300	1,696	6,600	31,038	31,814	75,878	-4,424	0,192	898,220
	0,200	1,796	3,390	15,941	16,340	76,981	-4,107	0,131	550,585
	0,100	1,896	1,026	4,827	4,947	78,758	-3,602	0,069	211,109
	0,099	1,897	1,000	4,703	4,820	78,794	-3,592	0,068	206,635
	0,000	1,996	0,000	0,000	0,000	87,128	-2,015	0,004	0,000

Tank Calibrations - doble fondo 2 estrib

Fluid Type = Water Ballast Specific gravity = 1,025

Permeability = 100 %

Trim = 0 m (+ve by stern); Heel = 0 deg to starboard

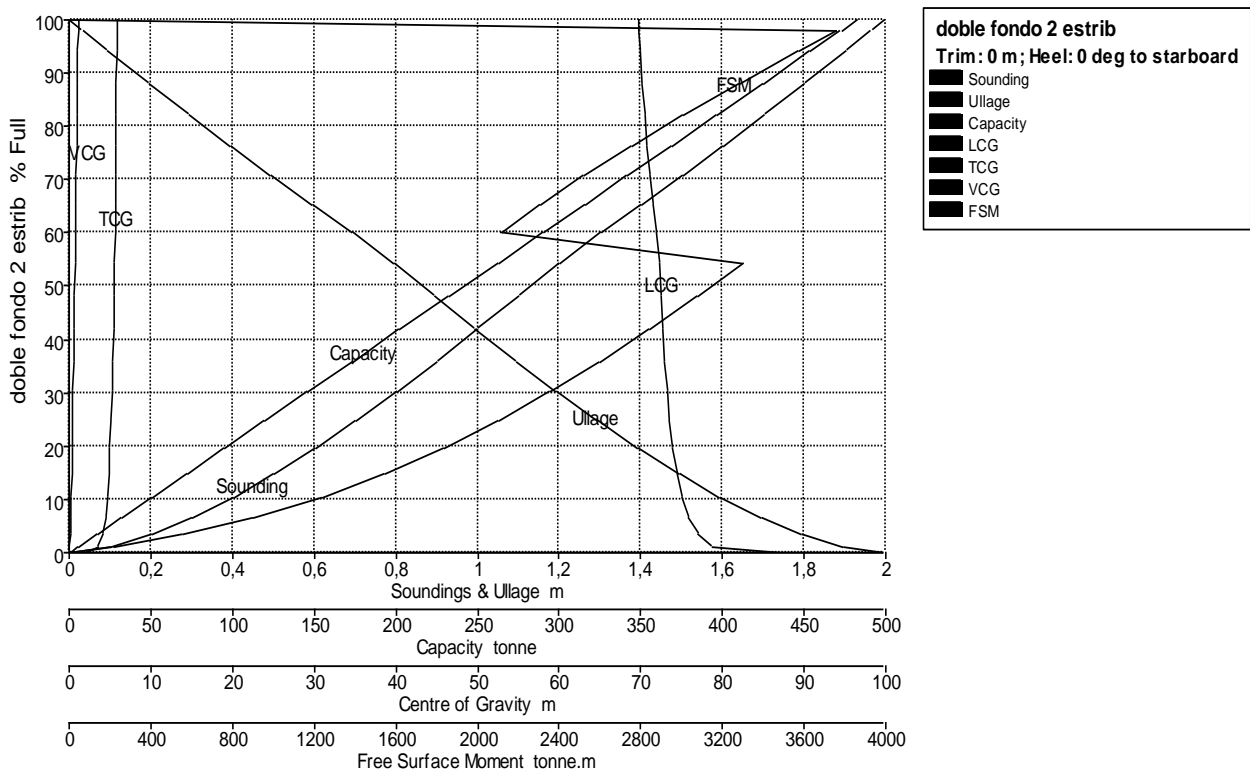

Tank Name	Sounding m	Ullage m	% Full	Capacity m ³	Capacity tonne	LCG m	TCG m	VCG m	FSM tonne.m
doble fondo 2 estrib	1,996	0,000	100,000	470,257	482,014	69,765	5,845	1,127	0,000
	1,964	0,032	98,000	460,852	472,374	69,832	5,830	1,109	3760,397
	1,963	0,033	97,900	460,382	471,891	69,836	5,830	1,108	3755,557
	1,900	0,096	94,027	442,169	453,223	69,974	5,802	1,074	3566,758
	1,800	0,196	87,970	413,687	424,030	70,217	5,762	1,020	3274,387
	1,700	0,296	82,083	386,000	395,650	70,489	5,725	0,968	3000,614
	1,600	0,396	76,363	359,101	368,078	70,794	5,693	0,916	2746,956
	1,500	0,496	70,812	332,997	341,321	71,138	5,665	0,866	2515,092
	1,400	0,596	65,428	307,681	315,373	71,525	5,643	0,818	2304,274
	1,300	0,696	60,217	283,173	290,252	71,963	5,628	0,772	2110,123
	1,200	0,796	54,452	256,062	262,464	72,301	5,587	0,721	3303,671
	1,100	0,896	48,032	225,875	231,522	72,485	5,507	0,663	3069,760
	1,000	0,996	41,829	196,706	201,623	72,693	5,422	0,605	2834,118
	0,900	1,096	35,861	168,637	172,853	72,932	5,329	0,547	2595,571

	0,800	1,196	30,145	141,757	145,301	73,209	5,227	0,488	2351,735
	0,700	1,296	24,707	116,186	119,090	73,537	5,113	0,430	2096,233
	0,600	1,396	19,577	92,061	94,363	73,937	4,984	0,371	1831,458
	0,500	1,496	14,799	69,596	71,336	74,441	4,834	0,312	1542,898
	0,400	1,596	10,444	49,112	50,340	75,074	4,654	0,252	1234,239
	0,300	1,696	6,600	31,038	31,814	75,878	4,424	0,192	898,220
	0,200	1,796	3,390	15,941	16,340	76,981	4,107	0,131	550,585
	0,100	1,896	1,026	4,827	4,947	78,758	3,602	0,069	211,109
	0,099	1,897	1,000	4,703	4,820	78,794	3,592	0,068	206,635
	0,000	1,996	0,000	0,000	0,000	87,128	2,015	0,004	0,000

Tank Calibrations - doble fondo 3 bab

Fluid Type = Water Ballast Specific gravity = 1,025

Permeability = 100 %

Trim = 0 m (+ve by stern); Heel = 0 deg to starboard

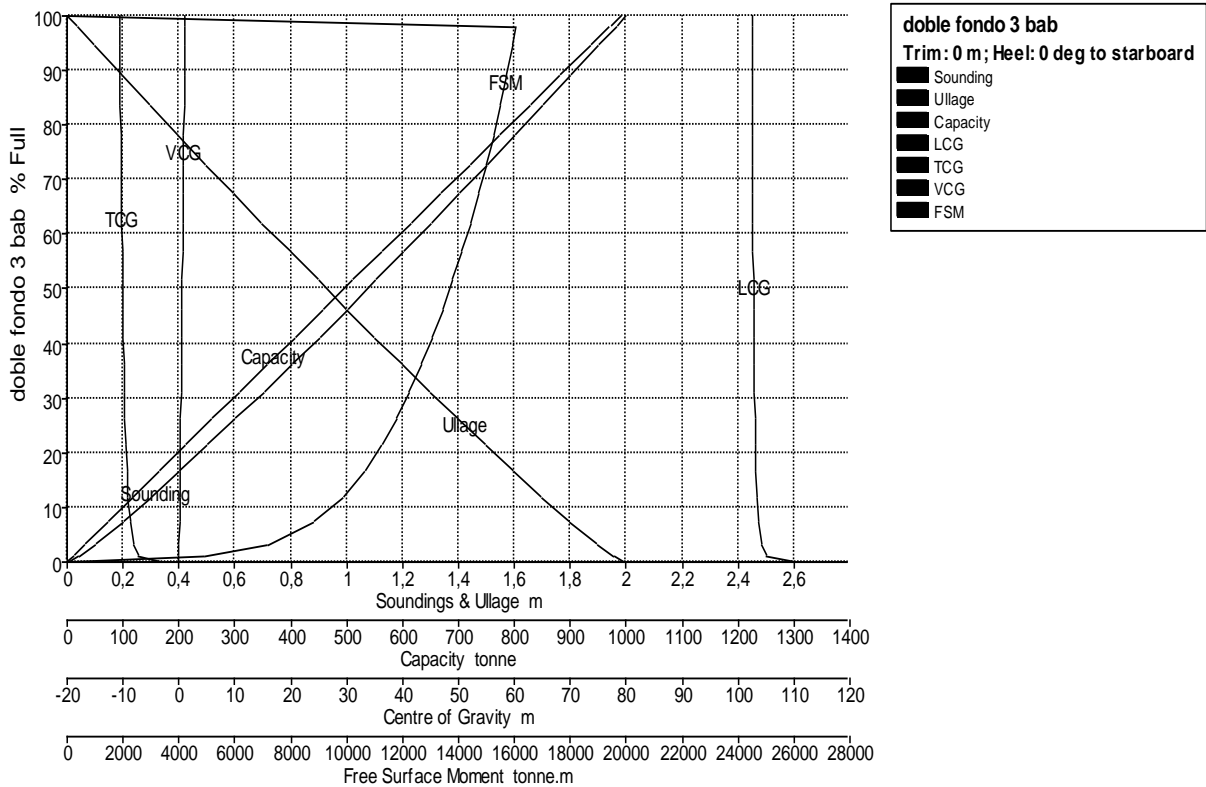

Tank Name	Sounding m	Ullage m	% Full	Capacity m ³	Capacity tonne	LCG m	TCG m	VCG m	FSM tonne.m
doble fondo 3 bab	2,000	0,000	100,000	966,221	990,377	102,473	-10,587	1,055	0,000
	1,964	0,036	98,000	946,897	970,569	102,481	-10,572	1,037	16056,512
	1,962	0,038	97,900	945,930	969,579	102,482	-10,572	1,036	16053,062
	1,900	0,100	94,465	912,740	935,558	102,496	-10,545	1,003	15927,321
	1,800	0,200	88,958	859,528	881,016	102,519	-10,501	0,951	15713,652
	1,700	0,300	83,480	806,600	826,765	102,544	-10,455	0,898	15499,795
	1,600	0,400	78,034	753,977	772,827	102,570	-10,405	0,846	15258,222
	1,500	0,500	72,623	701,695	719,238	102,598	-10,353	0,793	14998,639
	1,400	0,600	67,249	649,778	666,022	102,627	-10,297	0,741	14719,792
	1,300	0,700	61,917	598,253	613,209	102,658	-10,238	0,688	14436,269
	1,200	0,800	56,626	547,137	560,815	102,692	-10,174	0,636	14134,933
	1,100	0,900	51,383	496,472	508,884	102,729	-10,105	0,583	13803,694
	1,000	1,000	46,190	446,301	457,458	102,770	-10,030	0,531	13446,449
	0,900	1,100	41,052	396,657	406,574	102,815	-9,947	0,478	13079,179
	0,800	1,200	35,974	347,586	356,276	102,867	-9,856	0,426	12680,246
	0,700	1,300	30,961	299,151	306,630	102,928	-9,753	0,373	12238,191
	0,600	1,400	26,022	251,431	257,717	103,001	-9,633	0,321	11768,191
	0,500	1,500	21,167	204,520	209,633	103,092	-9,491	0,268	11236,503
	0,400	1,600	16,414	158,592	162,557	103,211	-9,315	0,215	10620,968
	0,300	1,700	11,788	113,897	116,744	103,378	-9,082	0,162	9860,700
	0,200	1,800	7,343	70,948	72,722	103,638	-8,740	0,109	8824,419
	0,100	1,900	3,202	30,937	31,711	104,146	-8,118	0,055	7118,017
	0,039	1,961	1,000	9,662	9,904	104,959	-7,237	0,022	4888,168
	0,000	2,000	0,000	0,000	0,000	110,558	-2,941	0,000	0,000

Tank Calibrations - doble fondo 3 estrib

Fluid Type = Water Ballast Specific gravity = 1,025

Permeability = 100 %

Trim = 0 m (+ve by stern); Heel = 0 deg to starboard

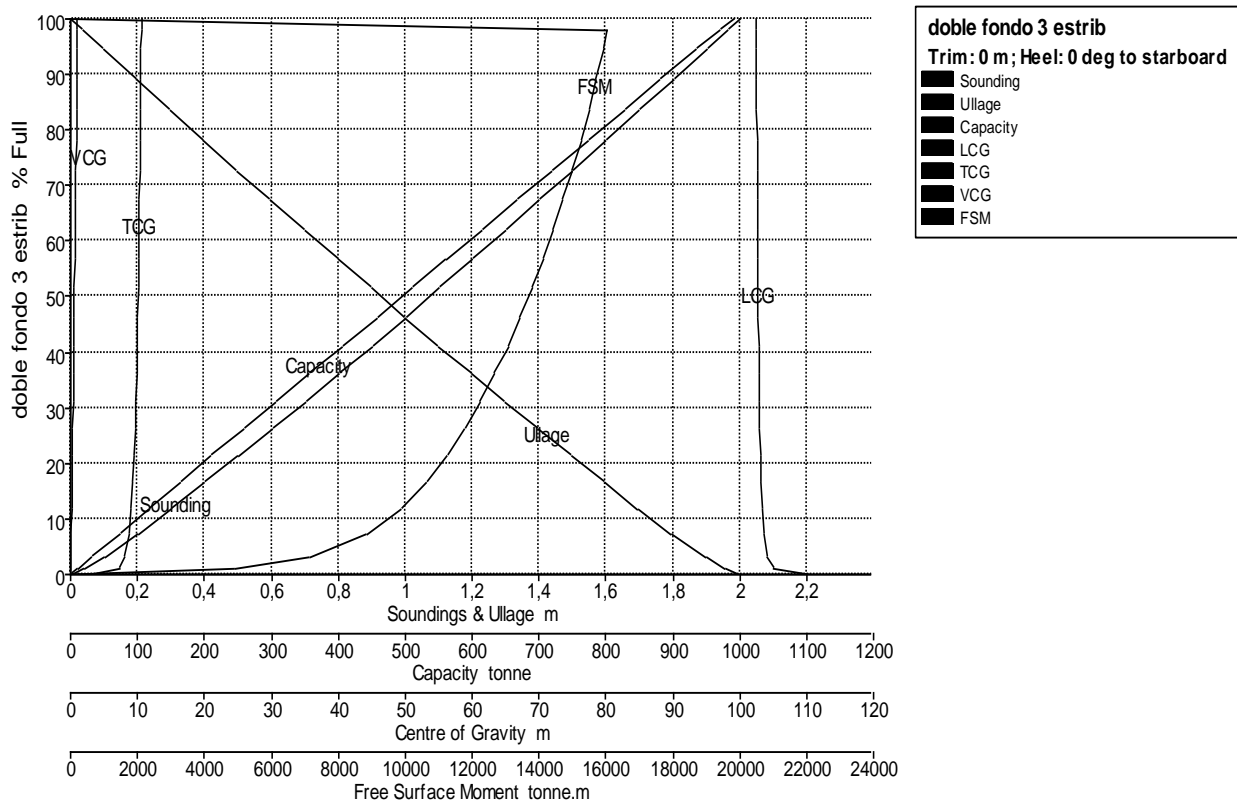

Tank Name	Sounding m	Ullage m	% Full	Capacity m ³	Capacity tonne	LCG m	TCG m	VCG m	FSM tonne.m
doble fondo 3 estrib	2,000	0,000	100,000	966,221	990,377	102,473	10,587	1,055	0,000
	1,964	0,036	98,000	946,897	970,569	102,481	10,572	1,037	16056,512
	1,962	0,038	97,900	945,930	969,579	102,482	10,572	1,036	16053,062
	1,900	0,100	94,465	912,740	935,558	102,496	10,545	1,003	15927,321
	1,800	0,200	88,958	859,528	881,016	102,519	10,501	0,951	15713,652
	1,700	0,300	83,480	806,600	826,765	102,544	10,455	0,898	15499,795
	1,600	0,400	78,034	753,977	772,827	102,570	10,405	0,846	15258,222
	1,500	0,500	72,623	701,695	719,238	102,598	10,353	0,793	14998,639
	1,400	0,600	67,249	649,778	666,022	102,627	10,297	0,741	14719,792
	1,300	0,700	61,917	598,253	613,209	102,658	10,238	0,688	14436,269
	1,200	0,800	56,626	547,137	560,815	102,692	10,174	0,636	14134,933
	1,100	0,900	51,383	496,472	508,884	102,729	10,105	0,583	13803,694
	1,000	1,000	46,190	446,301	457,458	102,770	10,030	0,531	13446,449
	0,900	1,100	41,052	396,657	406,574	102,815	9,947	0,478	13079,179

	0,800	1,200	35,974	347,586	356,276	102,867	9,856	0,426	12680,246
	0,700	1,300	30,961	299,151	306,630	102,928	9,753	0,373	12238,191
	0,600	1,400	26,022	251,431	257,717	103,001	9,633	0,321	11768,191
	0,500	1,500	21,167	204,520	209,633	103,092	9,491	0,268	11236,503
	0,400	1,600	16,414	158,592	162,557	103,211	9,315	0,215	10620,968
	0,300	1,700	11,788	113,897	116,744	103,378	9,082	0,162	9860,700
	0,200	1,800	7,343	70,948	72,722	103,638	8,740	0,109	8824,419
	0,100	1,900	3,202	30,937	31,711	104,146	8,118	0,055	7118,017
	0,039	1,961	1,000	9,662	9,904	104,959	7,237	0,022	4888,168
	0,000	2,000	0,000	0,000	0,000	110,558	2,941	0,000	0,000

Tank Calibrations - doble fondo 4 bab

Fluid Type = Water Ballast Specific gravity = 1,025

Permeability = 100 %

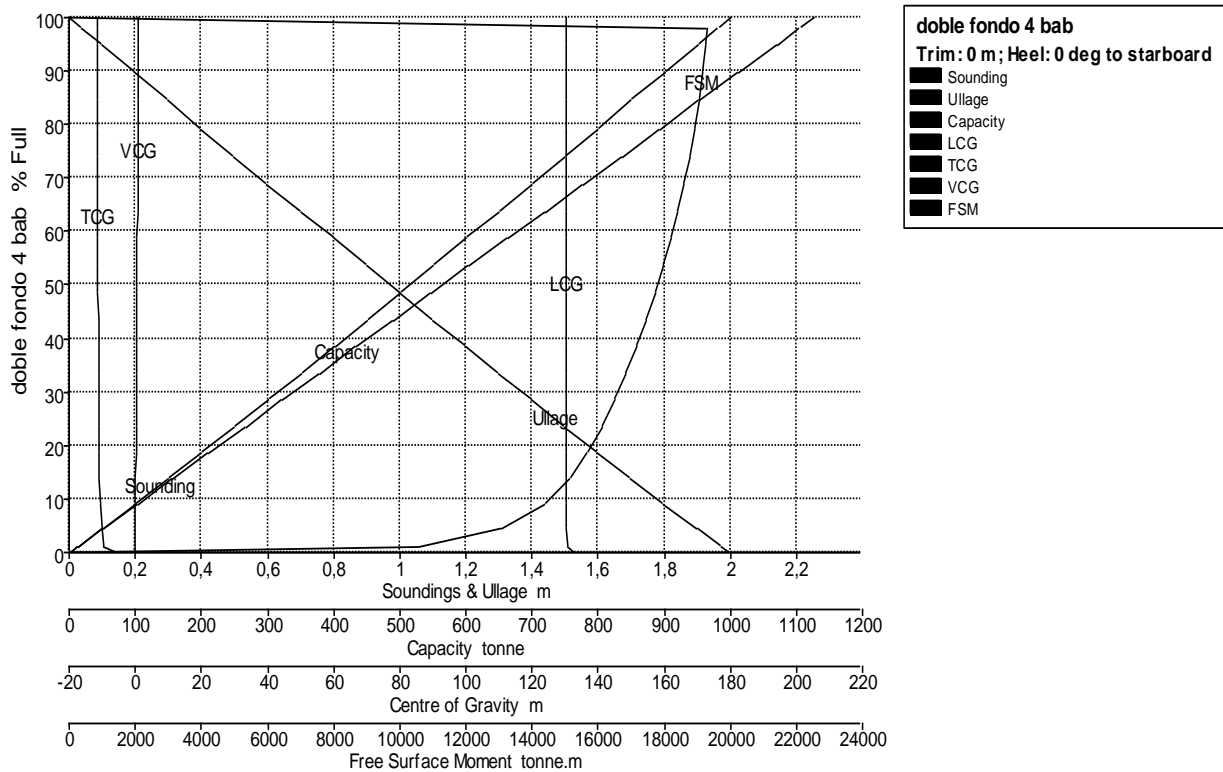

Trim = 0 m (+)

Tank Name	Soundin g m	Ullage m	% Full	Capacity m ³	Capacity tonne	LCG m	TCG m	VCG m	FSM tonne.m
doble fondo 4 bab	2,000	0,000	100,000	1099,640	1127,131	130,474	-11,546	1,022	0,000
	1,962	0,038	98,000	1077,647	1104,589	130,474	-11,538	1,003	19323,863
	1,960	0,040	97,900	1076,548	1103,462	130,474	-11,538	1,002	19321,884
	1,900	0,100	94,788	1042,322	1068,380	130,474	-11,525	0,971	19260,322
	1,800	0,200	89,584	985,107	1009,734	130,474	-11,502	0,920	19157,551
	1,700	0,300	84,391	927,993	951,193	130,474	-11,478	0,869	19055,147
	1,600	0,400	79,206	870,987	892,761	130,474	-11,452	0,818	18935,277
	1,500	0,500	74,035	814,119	834,472	130,474	-11,424	0,767	18778,690
	1,400	0,600	68,879	757,425	776,361	130,475	-11,394	0,716	18597,970
	1,300	0,700	63,740	700,914	718,437	130,475	-11,362	0,665	18418,251
	1,200	0,800	58,618	644,591	660,706	130,476	-11,328	0,614	18221,837
	1,100	0,900	53,516	588,488	603,200	130,477	-11,290	0,563	17993,022
	1,000	1,000	48,438	532,639	545,955	130,479	-11,250	0,511	17736,470
	0,900	1,100	43,383	477,059	488,986	130,481	-11,206	0,460	17477,350
	0,800	1,200	38,355	421,768	432,312	130,483	-11,157	0,409	17186,717
	0,700	1,300	33,357	366,808	375,979	130,486	-11,102	0,358	16857,836
	0,600	1,400	28,392	312,212	320,017	130,489	-11,040	0,307	16521,524
	0,500	1,500	23,463	258,009	264,460	130,494	-10,966	0,256	16126,148
	0,400	1,600	18,578	204,294	209,402	130,500	-10,876	0,205	15662,586
	0,300	1,700	13,743	151,121	154,899	130,509	-10,758	0,154	15133,920
	0,200	1,800	8,978	98,724	101,192	130,526	-10,588	0,103	14374,159
	0,100	1,900	4,317	47,470	48,657	130,567	-10,273	0,052	13065,157
	0,026	1,974	1,000	10,996	11,271	130,736	-9,542	0,013	10534,429
	0,000	2,000	0,000	0,000	0,000	132,991	-5,441	0,000	0,000

Tank Calibrations - doble fondo 4 estrib

Fluid Type = Water Ballast Specific gravity = 1,025

Permeability = 100 %

Trim = 0 m (+ve by stern); Heel = 0 deg to starboard

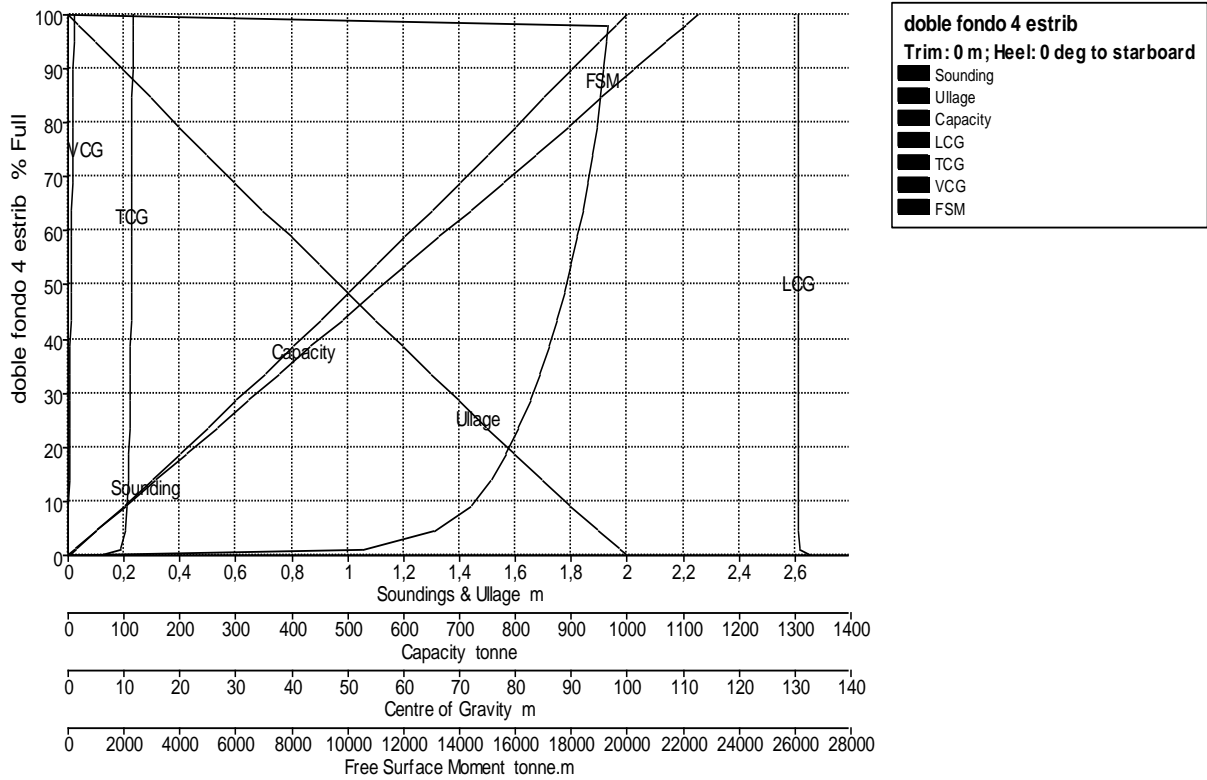

Tank Name	Sounding m	Ullage m	% Full	Capacity m ³	Capacity tonne	LCG m	TCG m	VCG m	FSM tonne.m
doble fondo 4 estrib	2,000	0,000	100,000	1099,640	1127,131	130,474	11,546	1,022	0,000
	1,962	0,038	98,000	1077,647	1104,589	130,474	11,538	1,003	19323,863
	1,960	0,040	97,900	1076,548	1103,462	130,474	11,538	1,002	19321,884
	1,900	0,100	94,788	1042,322	1068,380	130,474	11,525	0,971	19260,322
	1,800	0,200	89,584	985,107	1009,734	130,474	11,502	0,920	19157,551
	1,700	0,300	84,391	927,993	951,193	130,474	11,478	0,869	19055,147
	1,600	0,400	79,206	870,987	892,761	130,474	11,452	0,818	18935,277
	1,500	0,500	74,035	814,119	834,472	130,474	11,424	0,767	18778,690
	1,400	0,600	68,879	757,425	776,361	130,475	11,394	0,716	18597,970
	1,300	0,700	63,740	700,914	718,437	130,475	11,362	0,665	18418,251
	1,200	0,800	58,618	644,591	660,706	130,476	11,328	0,614	18221,837
	1,100	0,900	53,516	588,488	603,200	130,477	11,290	0,563	17993,022
	1,000	1,000	48,438	532,639	545,955	130,479	11,250	0,511	17736,470
	0,900	1,100	43,383	477,059	488,986	130,481	11,206	0,460	17477,350

	0,800	1,200	38,355	421,768	432,312	130,483	11,157	0,409	17186,717
	0,700	1,300	33,357	366,808	375,979	130,486	11,102	0,358	16857,836
	0,600	1,400	28,392	312,212	320,017	130,489	11,040	0,307	16521,524
	0,500	1,500	23,463	258,009	264,460	130,494	10,966	0,256	16126,148
	0,400	1,600	18,578	204,294	209,402	130,500	10,876	0,205	15662,586
	0,300	1,700	13,743	151,121	154,899	130,509	10,758	0,154	15133,920
	0,200	1,800	8,978	98,724	101,192	130,526	10,588	0,103	14374,159
	0,100	1,900	4,317	47,470	48,657	130,567	10,273	0,052	13065,157
	0,026	1,974	1,000	10,996	11,271	130,736	9,542	0,013	10534,429
	0,000	2,000	0,000	0,000	0,000	132,991	5,441	0,000	0,000

Tank Calibrations - doble fondo 5 bab

Fluid Type = Water Ballast Specific gravity = 1,025

Permeability = 100 %

Trim = 0 m (+ve by stern); Heel = 0 deg to starboard

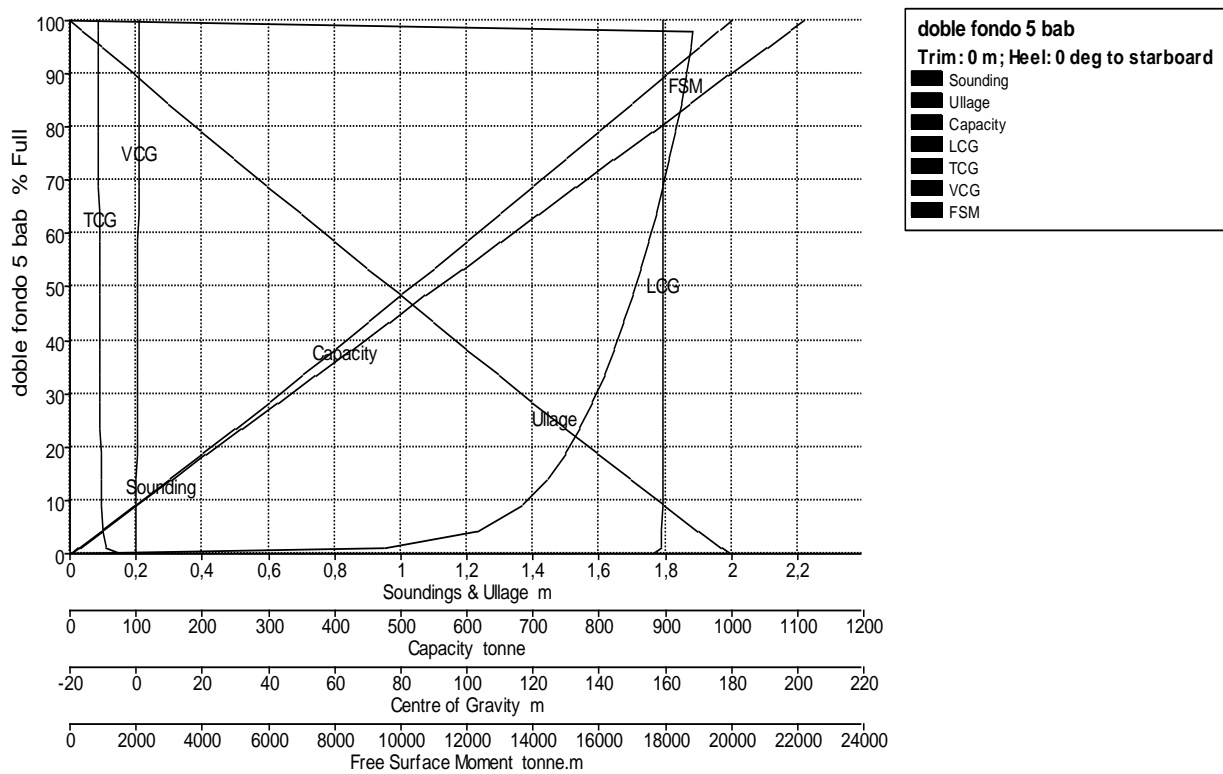

Tank Name	Soundin g m	Ullage m	% Full	Capacity m ³	Capacity tonne	LCG m	TCG m	VCG m	FSM tonne.m
doble fondo 5 bab	2,000	0,000	100,000	1083,942	1111,040	159,242	-11,417	1,025	0,000
	1,962	0,038	98,000	1062,263	1088,819	159,241	-11,408	1,005	18843,255
	1,960	0,040	97,900	1061,179	1087,708	159,241	-11,407	1,004	18841,174
	1,900	0,100	94,757	1027,111	1052,789	159,240	-11,393	0,974	18772,246
	1,800	0,200	89,525	970,403	994,663	159,238	-11,368	0,922	18643,009
	1,700	0,300	84,307	913,837	936,683	159,237	-11,341	0,871	18488,245
	1,600	0,400	79,104	857,443	878,880	159,235	-11,312	0,820	18312,511
	1,500	0,500	73,918	801,230	821,261	159,233	-11,282	0,769	18133,985
	1,400	0,600	68,750	745,209	763,839	159,231	-11,251	0,717	17941,145
	1,300	0,700	63,601	689,399	706,634	159,228	-11,217	0,666	17726,301
	1,200	0,800	58,474	633,825	649,671	159,226	-11,180	0,615	17495,391
	1,100	0,900	53,370	578,496	592,958	159,223	-11,142	0,564	17261,081
	1,000	1,000	48,289	523,425	536,511	159,219	-11,099	0,513	17011,068
	0,900	1,100	43,235	468,637	480,353	159,215	-11,053	0,461	16735,009
	0,800	1,200	38,208	414,155	424,509	159,210	-11,003	0,410	16453,272
	0,700	1,300	33,211	359,991	368,991	159,204	-10,945	0,359	16151,997
	0,600	1,400	28,248	306,187	313,842	159,197	-10,879	0,308	15803,871
	0,500	1,500	23,322	252,798	259,118	159,186	-10,800	0,257	15430,294
	0,400	1,600	18,439	199,864	204,861	159,170	-10,702	0,206	14997,336
	0,300	1,700	13,610	147,525	151,214	159,147	-10,571	0,155	14420,334
	0,200	1,800	8,853	95,960	98,359	159,105	-10,376	0,104	13676,592
	0,100	1,900	4,216	45,695	46,838	159,003	-10,006	0,052	12293,002
	0,027	1,973	1,000	10,839	11,110	158,672	-9,160	0,014	9476,459
	0,000	2,000	0,000	0,000	0,000	155,803	-4,227	0,000	0,000

Tank Calibrations - doble fondo 5 estrib

Fluid Type = Water Ballast Specific gravity = 1,025

Permeability = 100 %

Trim = 0 m (+ve by stern); Heel = 0 deg to starboard

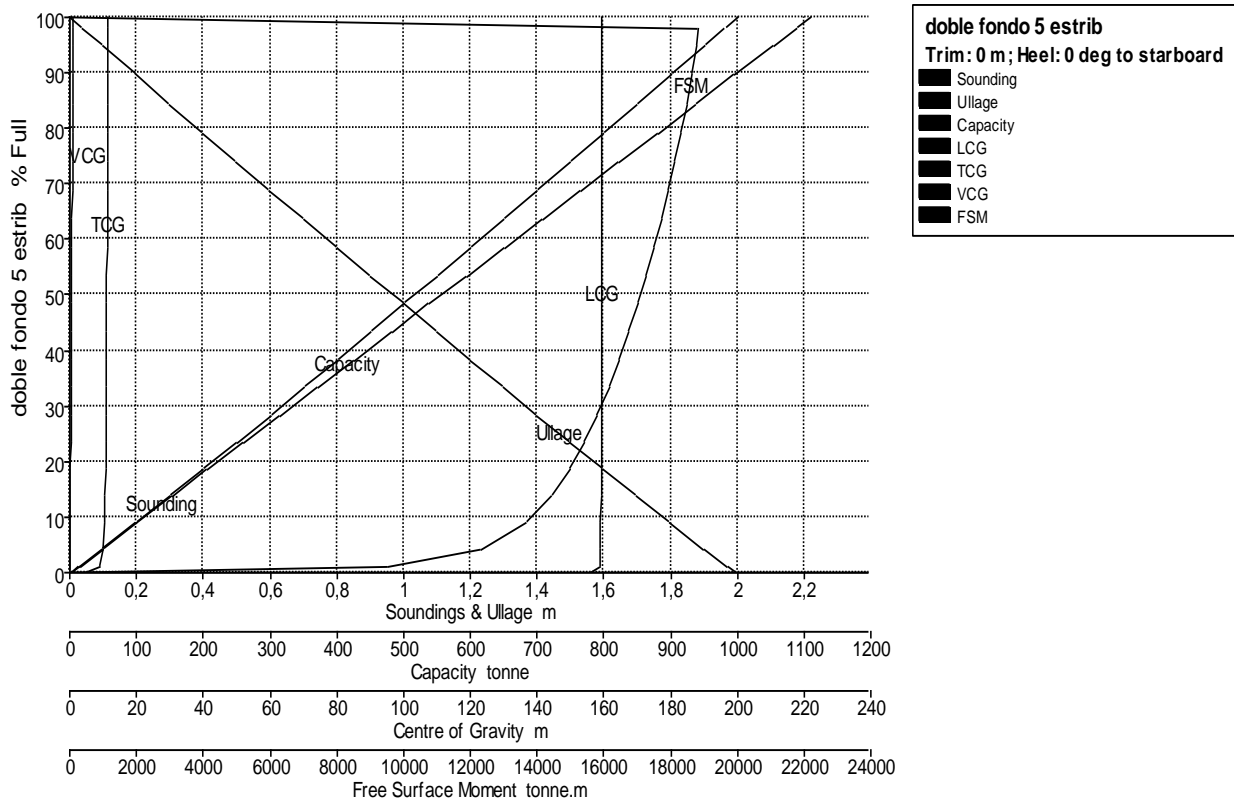

Tank Name	Sounding m	Ullage m	% Full	Capacity m ³	Capacity tonne	LCG m	TCG m	VCG m	FSM tonne.m
doble fondo 5 estrib	2,000	0,000	100,000	1083,942	1111,040	159,242	11,417	1,025	0,000
	1,962	0,038	98,000	1062,263	1088,819	159,241	11,408	1,005	18843,255
	1,960	0,040	97,900	1061,179	1087,708	159,241	11,407	1,004	18841,174
	1,900	0,100	94,757	1027,111	1052,789	159,240	11,393	0,974	18772,246
	1,800	0,200	89,525	970,403	994,663	159,238	11,368	0,922	18643,009
	1,700	0,300	84,307	913,837	936,683	159,237	11,341	0,871	18488,245
	1,600	0,400	79,104	857,443	878,880	159,235	11,312	0,820	18312,511
	1,500	0,500	73,918	801,230	821,261	159,233	11,282	0,769	18133,985
	1,400	0,600	68,750	745,209	763,839	159,231	11,251	0,717	17941,145
	1,300	0,700	63,601	689,399	706,634	159,228	11,217	0,666	17726,301
	1,200	0,800	58,474	633,825	649,671	159,226	11,180	0,615	17495,391
	1,100	0,900	53,370	578,496	592,958	159,223	11,142	0,564	17261,081
	1,000	1,000	48,289	523,425	536,511	159,219	11,099	0,513	17011,068

	0,900	1,100	43,235	468,637	480,353	159,215	11,053	0,461	16735,009
	0,800	1,200	38,208	414,155	424,509	159,210	11,003	0,410	16453,272
	0,700	1,300	33,211	359,991	368,991	159,204	10,945	0,359	16151,997
	0,600	1,400	28,248	306,187	313,842	159,197	10,879	0,308	15803,871
	0,500	1,500	23,322	252,798	259,118	159,186	10,800	0,257	15430,294
	0,400	1,600	18,439	199,864	204,861	159,170	10,702	0,206	14997,336
	0,300	1,700	13,610	147,525	151,214	159,147	10,571	0,155	14420,334
	0,200	1,800	8,853	95,960	98,359	159,105	10,376	0,104	13676,592
	0,100	1,900	4,216	45,695	46,838	159,003	10,006	0,052	12293,002
	0,027	1,973	1,000	10,839	11,110	158,672	9,160	0,014	9476,459
	0,000	2,000	0,000	0,000	0,000	155,803	4,227	0,000	0,000

Tank Calibrations - doble fondo 6 bab

Fluid Type = Water Ballast Specific gravity = 1,025

Permeability = 100 %

Trim = 0 m (+ve by stern); Heel = 0 deg to starboard

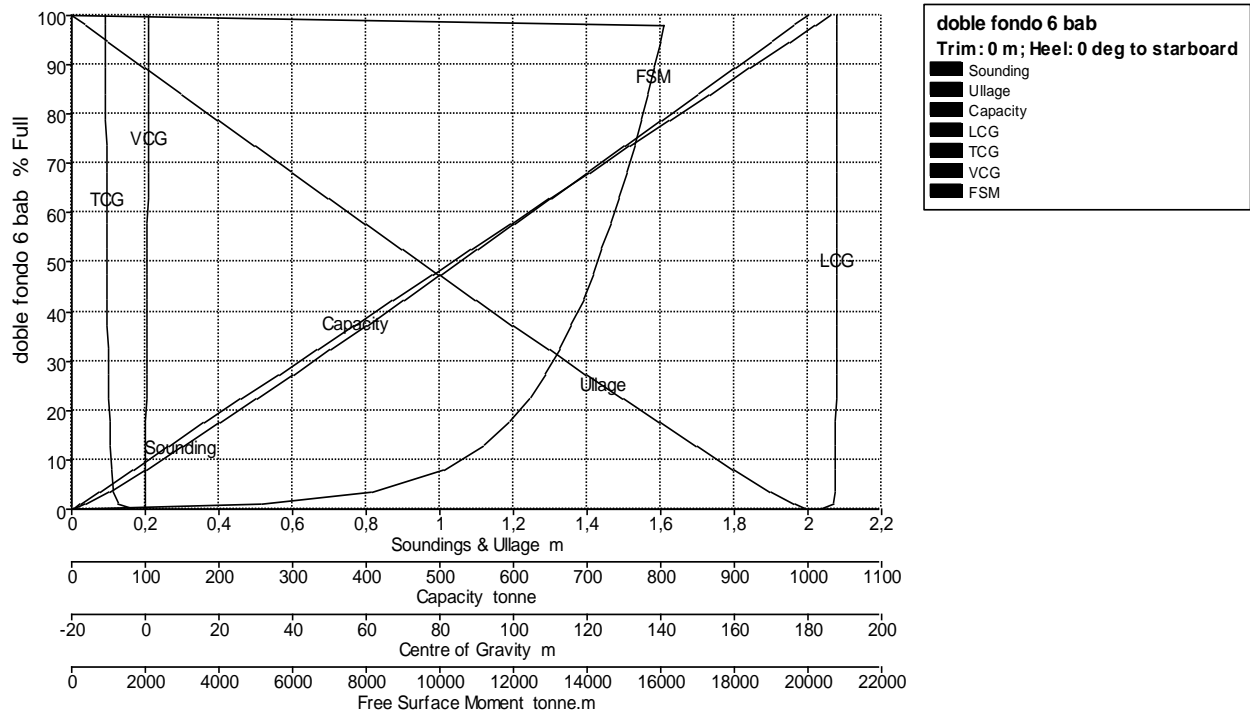

Tank Name	Sounding m	Ullage m	% Full	Capacity m³	Capacity tonne	LCG m	TCG m	VCG m	FSM tonne.m
doble fondo 6 bab	2,000	0,000	100,000	1004,979	1030,103	187,837	-10,789	1,039	0,000
	1,963	0,037	98,000	984,879	1009,501	187,835	-10,778	1,019	16110,522
	1,961	0,039	97,900	983,874	1008,471	187,835	-10,778	1,018	16107,542
	1,900	0,100	94,645	951,165	974,944	187,832	-10,759	0,987	16009,125
	1,800	0,200	89,308	897,528	919,966	187,826	-10,726	0,936	15845,024
	1,700	0,300	83,990	844,083	865,185	187,820	-10,692	0,884	15673,406
	1,600	0,400	78,692	790,842	810,613	187,814	-10,655	0,832	15489,629
	1,500	0,500	73,417	737,824	756,270	187,806	-10,616	0,781	15290,892
	1,400	0,600	68,165	685,040	702,166	187,798	-10,575	0,729	15087,546
	1,300	0,700	62,937	632,499	648,312	187,789	-10,530	0,678	14877,534
	1,200	0,800	57,734	580,217	594,722	187,779	-10,481	0,626	14652,605
	1,100	0,900	52,560	528,219	541,424	187,767	-10,428	0,575	14409,086
	1,000	1,000	47,416	476,521	488,434	187,753	-10,369	0,523	14158,878
	0,900	1,100	42,303	425,141	435,770	187,737	-10,304	0,471	13892,105
	0,800	1,200	37,227	374,120	383,473	187,718	-10,229	0,420	13586,442
	0,700	1,300	32,191	323,510	331,598	187,695	-10,142	0,368	13253,701
	0,600	1,400	27,200	273,351	280,185	187,665	-10,039	0,316	12889,906
	0,500	1,500	22,263	223,740	229,333	187,628	-9,911	0,264	12431,614
	0,400	1,600	17,396	174,823	179,194	187,579	-9,748	0,212	11888,383
	0,300	1,700	12,618	126,804	129,974	187,510	-9,523	0,160	11157,270
	0,200	1,800	7,975	80,150	82,154	187,402	-9,178	0,108	10087,929
	0,100	1,900	3,573	35,909	36,806	187,206	-8,516	0,055	8119,580
	0,035	1,965	1,000	10,050	10,301	186,920	-7,371	0,019	5113,276
	0,000	2,000	0,000	0,000	0,000	183,018	-2,723	0,000	0,000

Tank Calibrations - doble fondo 6 estrib

Fluid Type = Water Ballast Specific gravity = 1,025

Permeability = 100 %

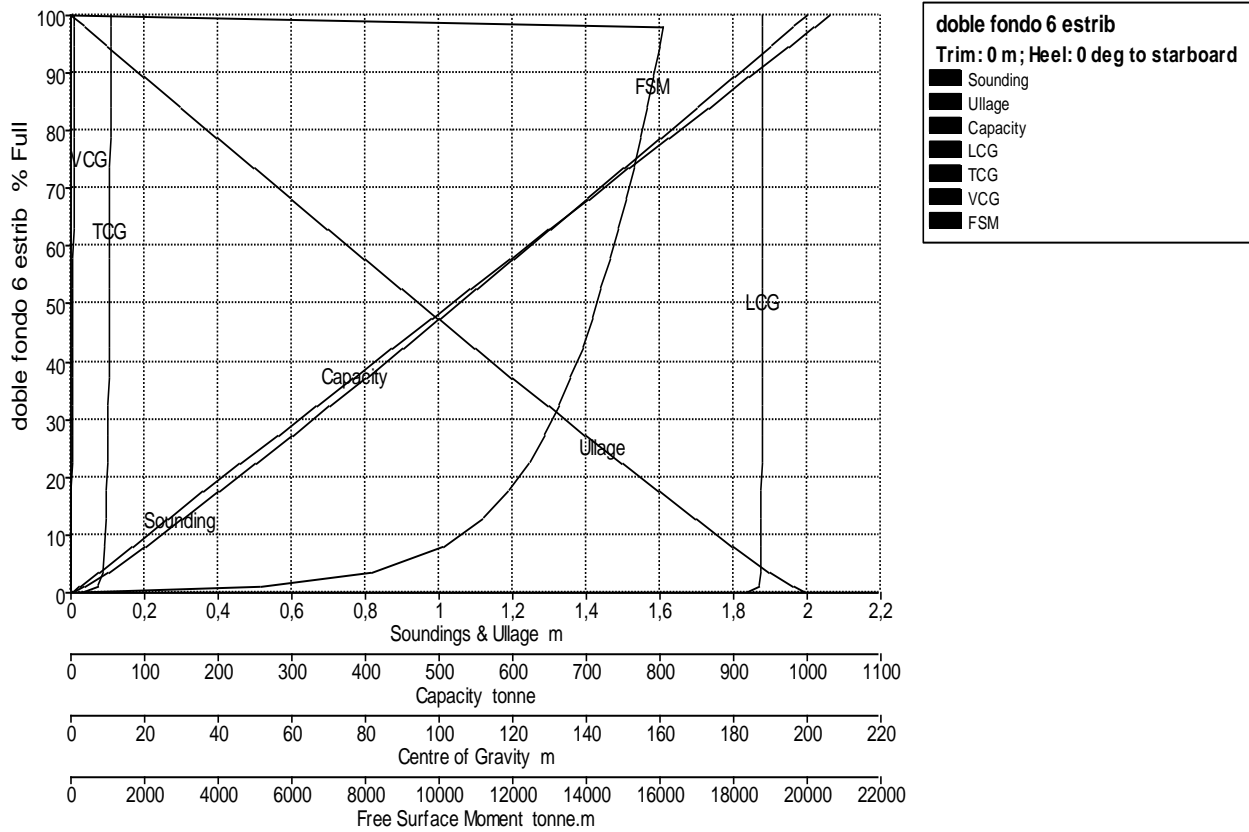

Trim = 0 m (+ve by stern); Heel = 0 deg to starboard

Tank Name	Sounding m	Ullage m	% Full	Capacity m ³	Capacity tonne	LCG m	TCG m	VCG m	FSM tonne.m
doble fondo 6 estrib	2,000	0,000	100,000	1004,979	1030,103	187,837	10,789	1,039	0,000
	1,963	0,037	98,000	984,879	1009,501	187,835	10,778	1,019	16110,522
	1,961	0,039	97,900	983,874	1008,471	187,835	10,778	1,018	16107,542
	1,900	0,100	94,645	951,165	974,944	187,832	10,759	0,987	16009,125
	1,800	0,200	89,308	897,528	919,966	187,826	10,726	0,936	15845,024
	1,700	0,300	83,990	844,083	865,185	187,820	10,692	0,884	15673,406
	1,600	0,400	78,692	790,842	810,613	187,814	10,655	0,832	15489,629

	1,500	0,500	73,417	737,824	756,270	187,806	10,616	0,781	15290,892
	1,400	0,600	68,165	685,040	702,166	187,798	10,575	0,729	15087,546
	1,300	0,700	62,937	632,499	648,312	187,789	10,530	0,678	14877,534
	1,200	0,800	57,734	580,217	594,722	187,779	10,481	0,626	14652,605
	1,100	0,900	52,560	528,219	541,424	187,767	10,428	0,575	14409,086
	1,000	1,000	47,416	476,521	488,434	187,753	10,369	0,523	14158,878
	0,900	1,100	42,303	425,141	435,770	187,737	10,304	0,471	13892,105
	0,800	1,200	37,227	374,120	383,473	187,718	10,229	0,420	13586,442
	0,700	1,300	32,191	323,510	331,598	187,695	10,142	0,368	13253,701
	0,600	1,400	27,200	273,351	280,185	187,665	10,039	0,316	12889,906
	0,500	1,500	22,263	223,740	229,333	187,628	9,911	0,264	12431,614
	0,400	1,600	17,396	174,823	179,194	187,579	9,748	0,212	11888,383
	0,300	1,700	12,618	126,804	129,974	187,510	9,523	0,160	11157,270
	0,200	1,800	7,975	80,150	82,154	187,402	9,178	0,108	10087,929
	0,100	1,900	3,573	35,909	36,806	187,206	8,516	0,055	8119,580
	0,035	1,965	1,000	10,050	10,301	186,920	7,371	0,019	5113,276
	0,000	2,000	0,000	0,000	0,000	183,018	2,723	0,000	0,000

Tank Calibrations - doble fondo 7 bab

Fluid Type = Water Ballast Specific gravity = 1,025

Permeability = 100 %

Trim = 0 m (+ve by stern);

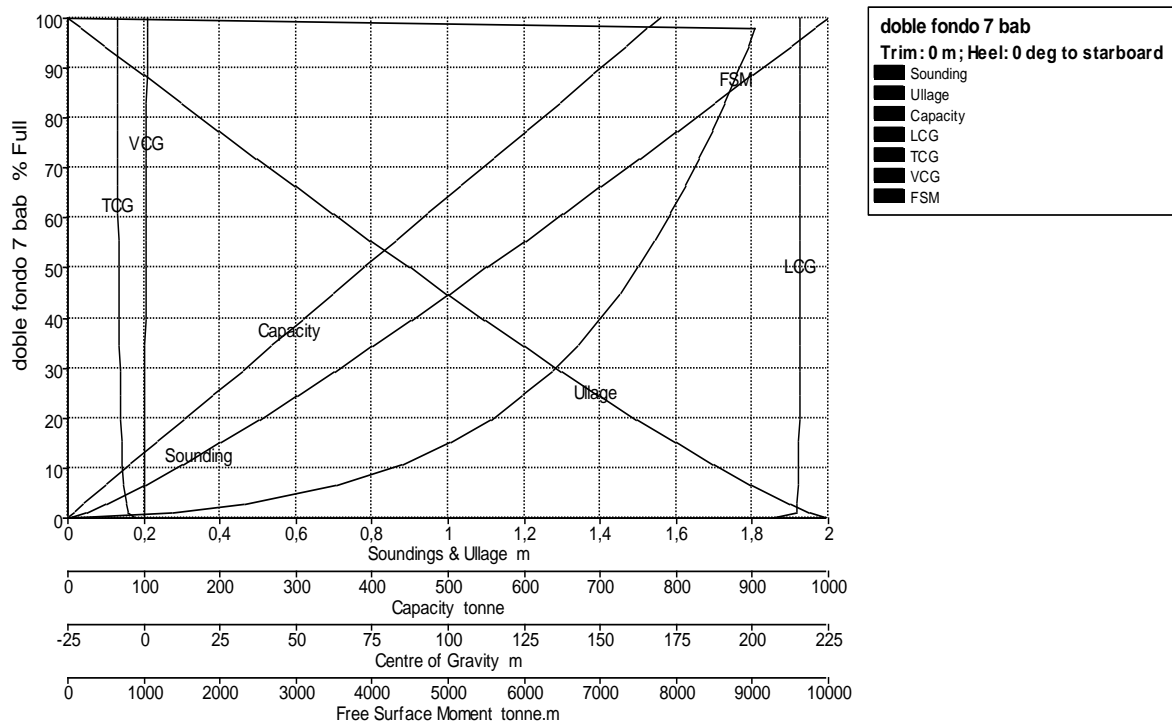

Tank Name	Sounding m	Ullage m	% Full	Capacity m ³	Capacity tonne	LCG m	TCG m	VCG m	FSM tonne.m
doble fondo 7 bab	2,000	0,000	100,000	759,023	777,999	215,850	-8,874	1,076	0,000
	1,965	0,035	98,000	743,843	762,439	215,844	-8,859	1,058	9043,269
	1,963	0,037	97,900	743,084	761,661	215,844	-8,858	1,057	9040,736
	1,900	0,100	94,290	715,684	733,576	215,834	-8,829	1,023	8948,950
	1,800	0,200	88,610	672,567	689,382	215,817	-8,782	0,970	8798,147
	1,700	0,300	82,967	629,739	645,482	215,799	-8,731	0,917	8638,485
	1,600	0,400	77,364	587,211	601,892	215,780	-8,677	0,864	8478,077
	1,500	0,500	71,804	545,007	558,633	215,760	-8,619	0,811	8302,849
	1,400	0,600	66,290	503,154	515,733	215,738	-8,557	0,758	8117,182
	1,300	0,700	60,825	461,674	473,216	215,715	-8,490	0,705	7919,432
	1,200	0,800	55,413	420,601	431,116	215,689	-8,417	0,651	7715,533
	1,100	0,900	50,060	379,966	389,465	215,662	-8,337	0,598	7491,637
	1,000	1,000	44,772	339,827	348,323	215,631	-8,248	0,545	7245,241
	0,900	1,100	39,556	300,237	307,743	215,598	-8,149	0,491	6976,346
	0,800	1,200	34,420	261,253	267,785	215,561	-8,037	0,437	6691,877
	0,700	1,300	29,375	222,964	228,538	215,519	-7,908	0,384	6356,757
	0,600	1,400	24,440	185,504	190,142	215,471	-7,758	0,330	5974,967
	0,500	1,500	19,632	149,009	152,734	215,415	-7,578	0,276	5552,960
	0,400	1,600	14,980	113,701	116,544	215,345	-7,354	0,222	5013,823
	0,300	1,700	10,532	79,938	81,937	215,256	-7,062	0,167	4379,348
	0,200	1,800	6,361	48,283	49,490	215,120	-6,650	0,112	3520,010
	0,100	1,900	2,628	19,945	20,444	214,851	-5,954	0,057	2303,531
	0,048	1,952	1,000	7,590	7,780	214,466	-5,257	0,028	1363,643
	0,000	2,000	0,000	0,000	0,000	206,265	-2,399	0,000	0,000

Tank Calibrations - doble fondo 7 estrib

Fluid Type = Water Ballast Specific gravity = 1,025

Permeability = 100 %

Trim = 0 m (+ve by stern); Heel = 0 deg to starboard

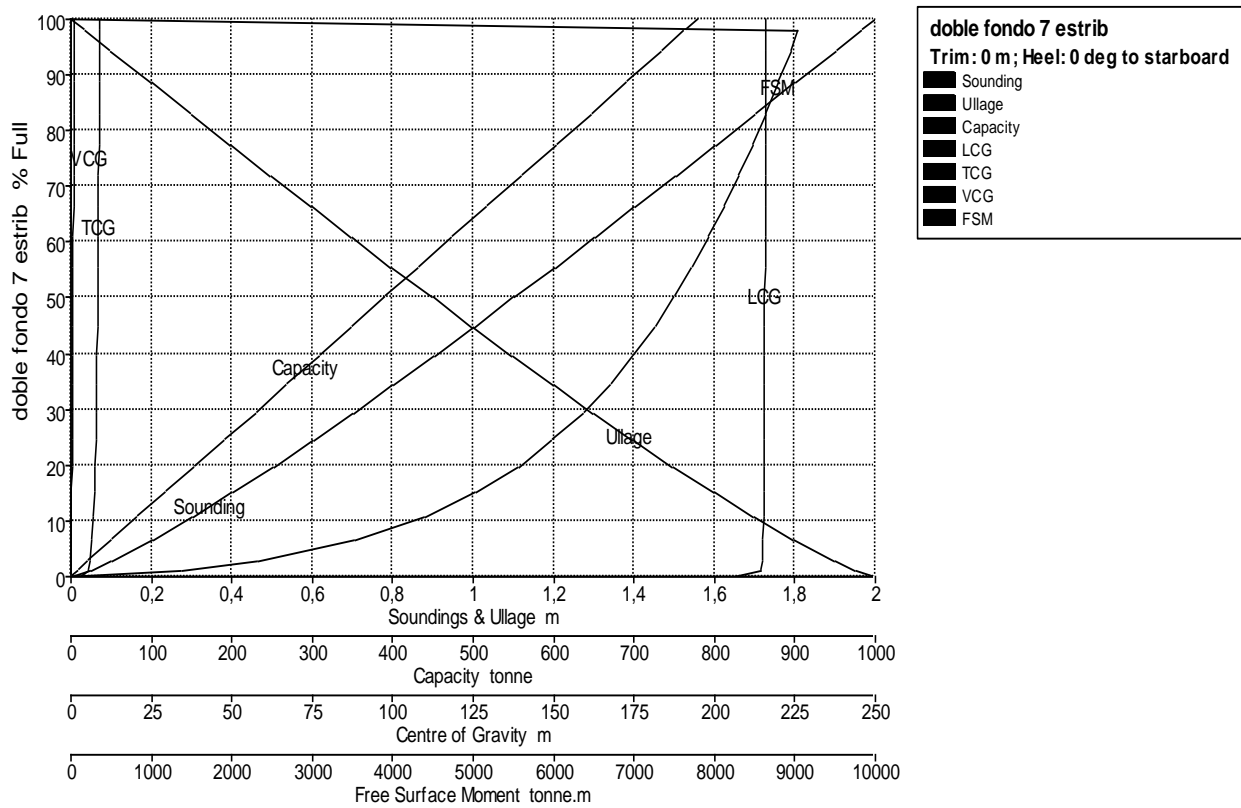

Tank Name	Sounding m	Ullage m	% Full	Capacity m ³	Capacity tonne	LCG m	TCG m	VCG m	FSM tonne.m
doble fondo 7 estrib	2,000	0,000	100,000	759,023	777,999	215,850	8,874	1,076	0,000
	1,965	0,035	98,000	743,843	762,439	215,844	8,859	1,058	9043,269
	1,963	0,037	97,900	743,084	761,661	215,844	8,858	1,057	9040,736
	1,900	0,100	94,290	715,684	733,576	215,834	8,829	1,023	8948,950
	1,800	0,200	88,610	672,567	689,382	215,817	8,782	0,970	8798,147
	1,700	0,300	82,967	629,739	645,482	215,799	8,731	0,917	8638,485
	1,600	0,400	77,364	587,211	601,892	215,780	8,677	0,864	8478,077
	1,500	0,500	71,804	545,007	558,633	215,760	8,619	0,811	8302,849
	1,400	0,600	66,290	503,154	515,733	215,738	8,557	0,758	8117,182
	1,300	0,700	60,825	461,674	473,216	215,715	8,490	0,705	7919,432
	1,200	0,800	55,413	420,601	431,116	215,689	8,417	0,651	7715,533
	1,100	0,900	50,060	379,966	389,465	215,662	8,337	0,598	7491,637
	1,000	1,000	44,772	339,827	348,323	215,631	8,248	0,545	7245,241
	0,900	1,100	39,556	300,237	307,743	215,598	8,149	0,491	6976,346

	0,800	1,200	34,420	261,253	267,785	215,561	8,037	0,437	6691,877
	0,700	1,300	29,375	222,964	228,538	215,519	7,908	0,384	6356,757
	0,600	1,400	24,440	185,504	190,142	215,471	7,758	0,330	5974,967
	0,500	1,500	19,632	149,009	152,734	215,415	7,578	0,276	5552,960
	0,400	1,600	14,980	113,701	116,544	215,345	7,354	0,222	5013,823
	0,300	1,700	10,532	79,938	81,937	215,256	7,062	0,167	4379,348
	0,200	1,800	6,361	48,283	49,490	215,120	6,650	0,112	3520,010
	0,100	1,900	2,628	19,945	20,444	214,851	5,954	0,057	2303,531
	0,048	1,952	1,000	7,590	7,780	214,466	5,257	0,028	1363,643
	0,000	2,000	0,000	0,000	0,000	206,265	2,399	0,000	0,000

Tank Calibrations - doble fondo 8 bab

Fluid Type = Water Ballast Specific gravity = 1,025

Permeability = 100 %

Trim = 0 m (+ve by stern); Heel = 0 deg to starboard

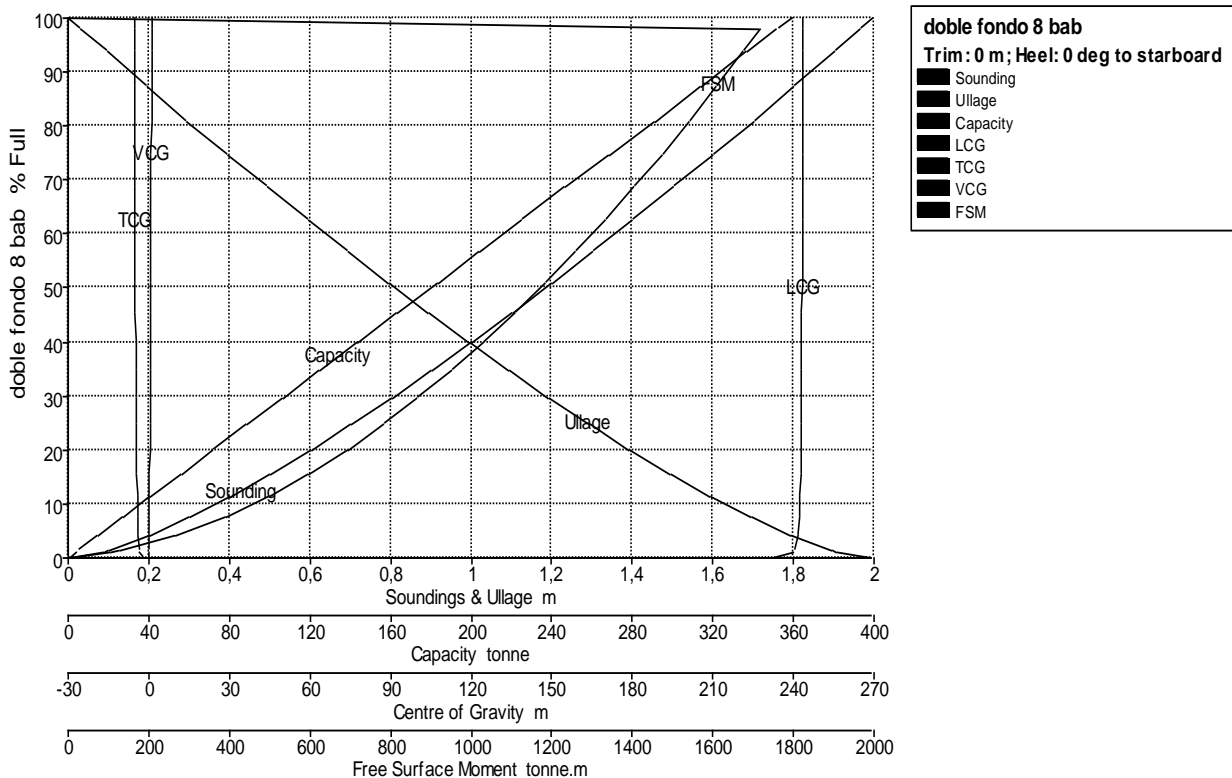

Tank Name	Sounding m	Ullage m	% Full	Capacity m ³	Capacity tonne	LCG m	TCG m	VCG m	FSM tonne.m
doble fondo 8 bab	1,996	0,000	100,000	350,263	359,020	243,484	-5,531	1,145	0,000
	1,966	0,030	98,000	343,258	351,840	243,476	-5,517	1,128	1717,040
	1,964	0,032	97,900	342,908	351,481	243,476	-5,516	1,127	1716,068
	1,900	0,096	93,699	328,193	336,398	243,460	-5,485	1,091	1673,657
	1,800	0,196	87,258	305,634	313,275	243,433	-5,435	1,035	1606,772
	1,700	0,296	80,922	283,441	290,527	243,404	-5,383	0,978	1539,887
	1,600	0,396	74,695	261,630	268,171	243,374	-5,329	0,922	1472,619
	1,500	0,496	68,582	240,217	246,223	243,342	-5,271	0,866	1403,194
	1,400	0,596	62,587	219,219	224,699	243,307	-5,211	0,809	1331,810
	1,300	0,696	56,717	198,658	203,625	243,268	-5,147	0,753	1257,853
	1,200	0,796	50,979	178,560	183,024	243,226	-5,080	0,697	1182,917
	1,100	0,896	45,381	158,953	162,927	243,178	-5,007	0,640	1107,865
	1,000	0,996	39,933	139,872	143,369	243,126	-4,929	0,584	1031,032
	0,900	1,096	34,648	121,358	124,392	243,066	-4,845	0,527	950,243
	0,800	1,196	29,537	103,458	106,044	242,995	-4,753	0,471	864,378
	0,700	1,296	24,616	86,220	88,375	242,908	-4,652	0,414	780,075
	0,600	1,396	19,907	69,726	71,469	242,803	-4,537	0,357	691,777
	0,500	1,496	15,442	54,087	55,440	242,668	-4,405	0,300	593,792
	0,400	1,596	11,260	39,438	40,424	242,479	-4,249	0,243	493,680
	0,300	1,696	7,419	25,985	26,635	242,200	-4,054	0,186	388,078
	0,200	1,796	4,031	14,119	14,472	241,701	-3,798	0,128	263,829
	0,100	1,896	1,311	4,593	4,708	240,482	-3,398	0,068	124,611
	0,086	1,911	1,000	3,503	3,590	240,106	-3,319	0,059	103,952
	0,000	1,996	0,000	0,000	0,000	231,644	-2,018	0,004	0,000

Tank Calibrations - doble fondo 8 estrib

Fluid Type = Water Ballast Specific gravity = 1,025

Permeability = 100 %

Trim = 0 m (+ve by stern); Heel = 0 deg to starboard

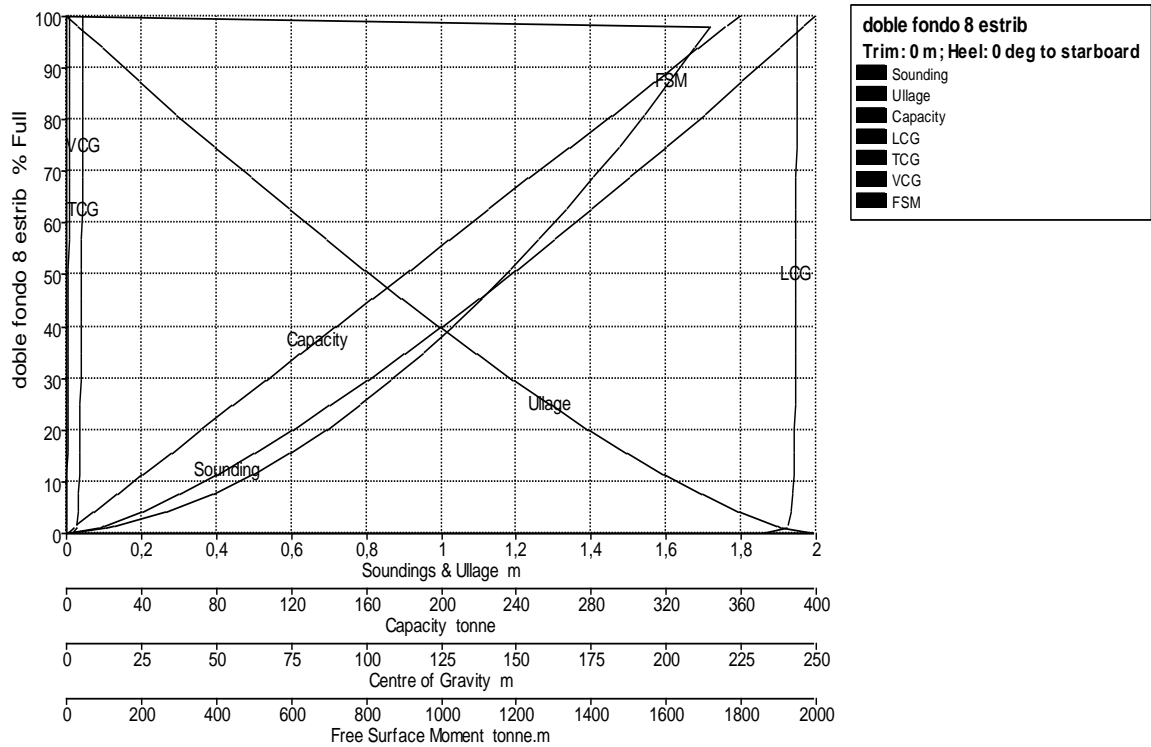

Tank Name	Sounding m	Ullage m	% Full	Capacity m ³	Capacity tonne	LCG m	TCG m	VCG m	FSM tonne.m
doble fondo 8 estrib	1,996	0,000	100,000	350,263	359,020	243,484	5,531	1,145	0,000
	1,966	0,030	98,000	343,258	351,840	243,476	5,517	1,128	1717,040
	1,964	0,032	97,900	342,908	351,481	243,476	5,516	1,127	1716,068
	1,900	0,096	93,699	328,193	336,398	243,460	5,485	1,091	1673,657
	1,800	0,196	87,258	305,634	313,275	243,433	5,435	1,035	1606,772
	1,700	0,296	80,922	283,441	290,527	243,404	5,383	0,978	1539,887
	1,600	0,396	74,695	261,630	268,171	243,374	5,329	0,922	1472,619
	1,500	0,496	68,582	240,217	246,223	243,342	5,271	0,866	1403,194
	1,400	0,596	62,587	219,219	224,699	243,307	5,211	0,809	1331,810
	1,300	0,696	56,717	198,658	203,625	243,268	5,147	0,753	1257,853
	1,200	0,796	50,979	178,560	183,024	243,226	5,080	0,697	1182,917
	1,100	0,896	45,381	158,953	162,927	243,178	5,007	0,640	1107,865
	1,000	0,996	39,933	139,872	143,369	243,126	4,929	0,584	1031,032
	0,900	1,096	34,648	121,358	124,392	243,066	4,845	0,527	950,243
	0,800	1,196	29,537	103,458	106,044	242,995	4,753	0,471	864,378
	0,700	1,296	24,616	86,220	88,375	242,908	4,652	0,414	780,075

	0,600	1,396	19,907	69,726	71,469	242,803	4,537	0,357	691,777
	0,500	1,496	15,442	54,087	55,440	242,668	4,405	0,300	593,792
	0,400	1,596	11,260	39,438	40,424	242,479	4,249	0,243	493,680
	0,300	1,696	7,419	25,985	26,635	242,200	4,054	0,186	388,078
	0,200	1,796	4,031	14,119	14,472	241,701	3,798	0,128	263,829
	0,100	1,896	1,311	4,593	4,708	240,482	3,398	0,068	124,611
	0,086	1,911	1,000	3,503	3,590	240,106	3,319	0,059	103,952
	0,000	1,996	0,000	0,000	0,000	231,644	2,018	0,004	0,000

Tank Calibrations - doble fondo 9 bab

Fluid Type = Water Ballast Specific gravity = 1,025

Permeability = 100 %

Trim = 0 m (+ve by stern); Heel = 0 deg to starboard

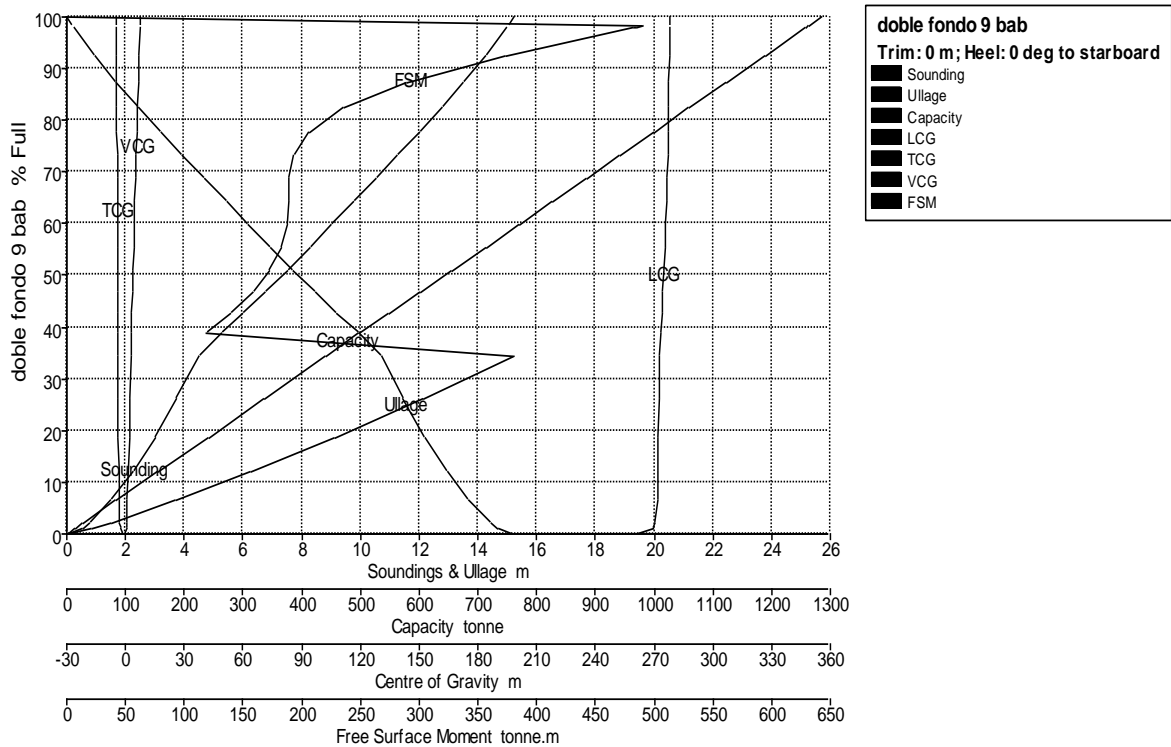

Tank Name	Sounding m	Ullage m	% Full	Capacity m ³	Capacity tonne	LCG m	TCG m	VCG m	FSM tonne.m
doble fondo 9 bab	15,204	0,000	100,000	1252,122	1283,425	277,973	-4,523	7,632	0,000

	15,000	0,204	98,328	1231,191	1261,971	277,922	-4,503	7,504	490,848
	14,959	0,245	98,000	1227,079	1257,756	277,912	-4,499	7,479	483,505
	14,947	0,257	97,900	1225,827	1256,473	277,909	-4,498	7,471	481,294
	14,250	0,954	92,545	1158,771	1187,740	277,735	-4,441	7,056	372,656
	13,500	1,704	87,270	1092,722	1120,040	277,545	-4,396	6,641	288,866
	12,750	2,454	82,389	1031,604	1057,395	277,347	-4,363	6,254	234,912
	12,000	3,204	77,762	973,681	998,023	277,134	-4,337	5,887	205,217
	11,250	3,954	73,262	917,335	940,269	276,899	-4,314	5,531	192,360
	10,500	4,704	68,801	861,473	883,010	276,632	-4,291	5,182	188,720
	9,750	5,454	64,338	805,596	825,736	276,326	-4,264	4,836	188,437
	9,000	6,204	59,871	749,656	768,398	275,972	-4,234	4,493	187,261
	8,250	6,954	55,422	693,949	711,298	275,562	-4,199	4,158	182,530
	7,500	7,704	51,030	638,953	654,926	275,087	-4,163	3,834	172,811
	6,750	8,454	46,740	585,240	599,871	274,537	-4,126	3,528	158,571
	6,000	9,204	42,603	533,438	546,774	273,903	-4,091	3,246	139,437
	5,250	9,954	38,663	484,104	496,206	273,173	-4,064	2,999	118,634
	4,500	10,704	34,282	429,253	439,984	272,451	-4,030	2,759	380,322
	3,750	11,454	26,097	326,762	334,931	272,340	-3,874	2,315	302,707
	3,000	12,204	18,639	233,388	239,223	272,192	-3,698	1,870	227,066
	2,250	12,954	12,026	150,586	154,351	271,976	-3,496	1,424	156,051
	1,500	13,704	6,411	80,268	82,275	271,608	-3,251	0,978	92,147
	0,750	14,454	2,070	25,920	26,568	270,706	-2,913	0,529	36,654
	0,496	14,708	1,000	12,521	12,834	269,908	-2,749	0,373	20,595
	0,000	15,204	0,000	0,000	0,000	260,420	-2,000	0,046	0,000

Tank Calibrations - doble fondo 9 estrib

Fluid Type = Water Ballast Specific gravity = 1,025

Permeability = 100 %

Trim = 0 m (+ve by stern); Heel = 0 deg to starboard

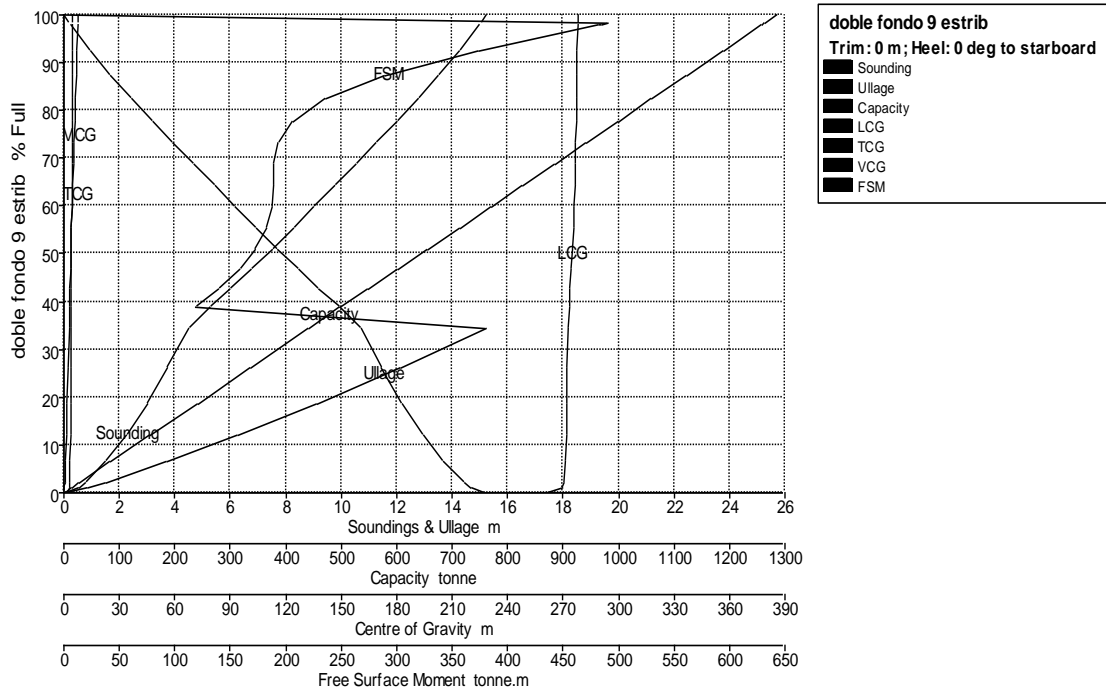

Tank Name	Sounding m	Ullage m	% Full	Capacity m ³	Capacity tonne	LCG m	TCG m	VCG m	FSM tonne.m
doble fondo 9 estrib	15,204	0,000	100,000	1252,122	1283,425	277,973	4,523	7,632	0,000
	15,000	0,204	98,328	1231,191	1261,971	277,922	4,503	7,504	490,848
	14,959	0,245	98,000	1227,079	1257,756	277,912	4,499	7,479	483,505
	14,947	0,257	97,900	1225,827	1256,473	277,909	4,498	7,471	481,294
	14,250	0,954	92,545	1158,771	1187,740	277,735	4,441	7,056	372,656
	13,500	1,704	87,270	1092,722	1120,040	277,545	4,396	6,641	288,866
	12,750	2,454	82,389	1031,604	1057,395	277,347	4,363	6,254	234,912
	12,000	3,204	77,762	973,681	998,023	277,134	4,337	5,887	205,217
	11,250	3,954	73,262	917,335	940,269	276,899	4,314	5,531	192,360
	10,500	4,704	68,801	861,473	883,010	276,632	4,291	5,182	188,720
	9,750	5,454	64,338	805,596	825,736	276,326	4,264	4,836	188,437
	9,000	6,204	59,871	749,656	768,398	275,972	4,234	4,493	187,261
	8,250	6,954	55,422	693,949	711,298	275,562	4,199	4,158	182,530
	7,500	7,704	51,030	638,953	654,926	275,087	4,163	3,834	172,811
	6,750	8,454	46,740	585,240	599,871	274,537	4,126	3,528	158,571
	6,000	9,204	42,603	533,438	546,774	273,903	4,091	3,246	139,437

	5,250	9,954	38,663	484,104	496,206	273,173	4,064	2,999	118,634
	4,500	10,704	34,282	429,253	439,984	272,451	4,030	2,759	380,322
	3,750	11,454	26,097	326,762	334,931	272,340	3,874	2,315	302,707
	3,000	12,204	18,639	233,388	239,223	272,192	3,698	1,870	227,066
	2,250	12,954	12,026	150,586	154,351	271,976	3,496	1,424	156,051
	1,500	13,704	6,411	80,268	82,275	271,608	3,251	0,978	92,147
	0,750	14,454	2,070	25,920	26,568	270,706	2,913	0,529	36,654
	0,496	14,708	1,000	12,521	12,834	269,908	2,749	0,373	20,595
	0,000	15,204	0,000	0,000	0,000	260,420	2,000	0,046	0,000

Tank Calibrations - doble casco 1 bab

Fluid Type = Water Ballast Specific gravity = 1,025

Permeability = 100 %

Trim = 0 m (+ve by stern); Heel = 0 deg to starboard

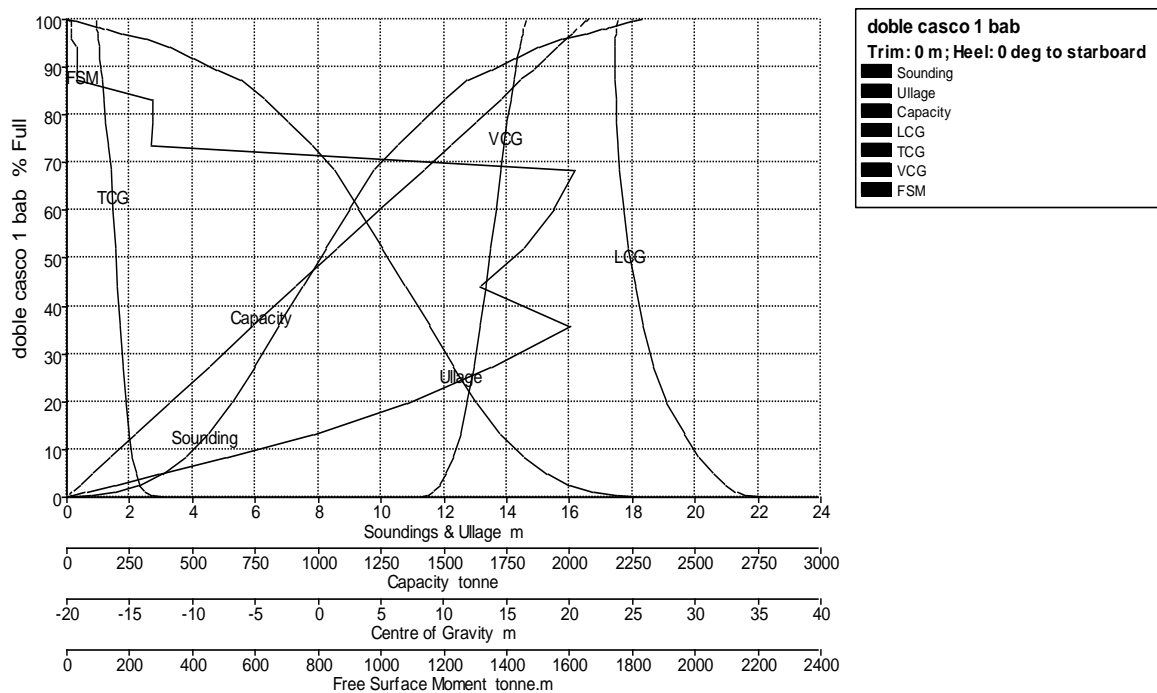

Tank Name	Sounding m	Ullage m	% Full	Capacity m ³	Capacity tonne	LCG m	TCG m	VCG m	FSM tonne.m
doble casco 1 bab	18,304	0,000	100,000	2022,168	2072,723	23,829	-17,658	16,540	0,000

	18,000	0,304	99,494	2011,938	2062,236	23,803	-17,641	16,491	16,395
	17,250	1,054	98,248	1986,735	2036,404	23,740	-17,599	16,374	16,395
	17,101	1,204	98,000	1981,725	2031,268	23,727	-17,591	16,351	16,395
	17,041	1,264	97,900	1979,703	2029,195	23,722	-17,588	16,342	16,395
	16,500	1,804	97,001	1961,533	2010,571	23,675	-17,557	16,263	16,395
	15,750	2,554	95,755	1936,330	1984,739	23,608	-17,513	16,159	16,395
	15,000	3,304	94,212	1905,131	1952,759	23,565	-17,457	16,040	31,065
	14,250	4,054	91,851	1857,379	1903,813	23,592	-17,368	15,868	31,065
	13,500	4,804	89,489	1809,627	1854,867	23,620	-17,274	15,707	31,065
	12,750	5,554	87,128	1761,875	1805,921	23,650	-17,176	15,557	31,065
	12,000	6,304	83,279	1684,049	1726,150	23,702	-17,047	15,333	272,655
	11,250	7,054	78,409	1585,562	1625,201	23,776	-16,885	15,059	272,064
	10,500	7,804	73,553	1487,361	1524,545	23,858	-16,703	14,801	267,256
	9,750	8,554	68,528	1385,744	1420,388	23,960	-16,504	14,550	1618,086
	9,000	9,304	60,126	1215,851	1246,247	24,290	-16,350	14,140	1550,223
	8,250	10,054	51,889	1049,279	1075,511	24,708	-16,164	13,729	1454,154
	7,500	10,804	43,908	887,895	910,092	25,244	-15,941	13,319	1317,764
	6,750	11,554	35,602	719,934	737,932	25,883	-15,720	12,876	1603,191
	6,000	12,304	27,218	550,387	564,147	26,691	-15,511	12,380	1349,502
	5,250	13,054	19,622	396,789	406,709	27,797	-15,289	11,855	1078,256
	4,500	13,804	13,198	266,878	273,550	29,172	-15,060	11,300	784,345
	3,750	14,554	8,383	169,514	173,751	30,324	-14,784	10,758	506,091
	3,000	15,304	4,825	97,573	100,012	31,496	-14,498	10,208	294,548
	2,250	16,054	2,440	49,332	50,565	32,489	-14,167	9,670	148,882
	1,521	16,783	1,000	20,222	20,727	33,321	-13,781	9,161	60,257
	1,500	16,804	0,969	19,605	20,095	33,342	-13,768	9,147	57,978
	0,750	17,554	0,203	4,106	4,209	34,053	-13,192	8,644	12,980
	0,000	18,304	0,000	0,000	0,000	35,757	-12,105	8,106	0,000

Tank Calibrations - doble casco 1 estrib

Fluid Type = Water Ballast Specific gravity = 1,025

Permeability = 100 %

Trim = 0 m (+ve by stern); Heel = 0 deg to starboard

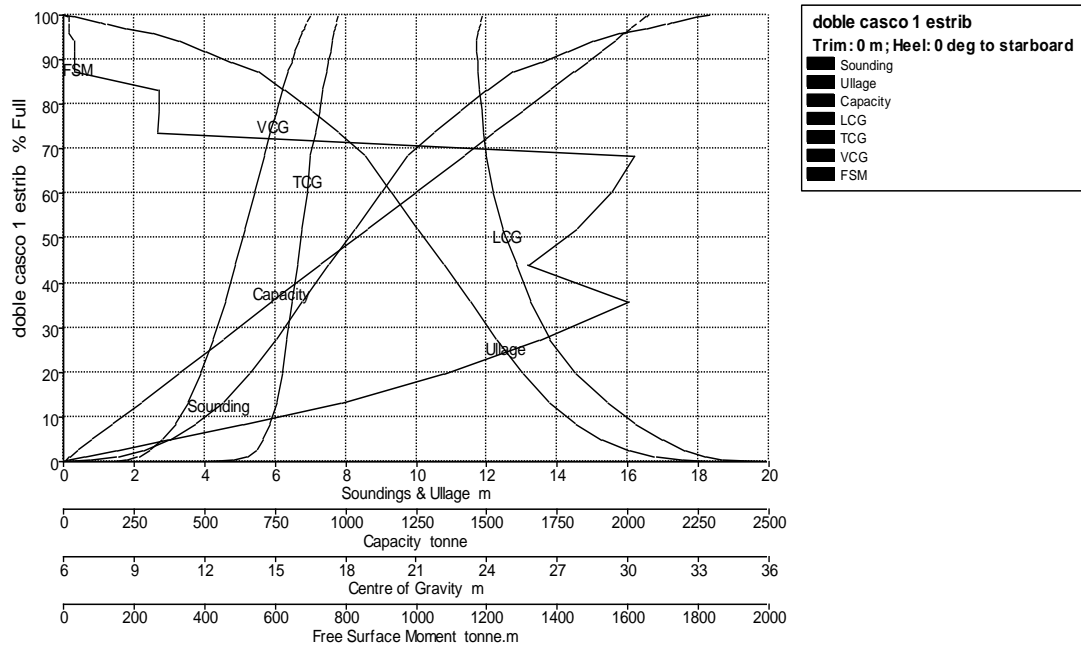

Tank Name	Sounding m	Ullage m	% Full	Capacity m ³	Capacity tonne	LCG m	TCG m	VCG m	FSM tonne.m
doble casco 1 estrib	18,304	0,000	100,000	2022,168	2072,723	23,829	17,658	16,540	0,000
	18,000	0,304	99,494	2011,938	2062,236	23,803	17,641	16,491	16,395
	17,250	1,054	98,248	1986,735	2036,404	23,740	17,599	16,374	16,395
	17,101	1,204	98,000	1981,725	2031,268	23,727	17,591	16,351	16,395
	17,041	1,264	97,900	1979,703	2029,195	23,722	17,588	16,342	16,395
	16,500	1,804	97,001	1961,533	2010,571	23,675	17,557	16,263	16,395
	15,750	2,554	95,755	1936,330	1984,739	23,608	17,513	16,159	16,395
	15,000	3,304	94,212	1905,131	1952,759	23,565	17,457	16,040	31,065
	14,250	4,054	91,851	1857,379	1903,813	23,592	17,368	15,868	31,065
	13,500	4,804	89,489	1809,627	1854,867	23,620	17,274	15,707	31,065
	12,750	5,554	87,128	1761,875	1805,921	23,650	17,176	15,557	31,065
	12,000	6,304	83,279	1684,049	1726,150	23,702	17,047	15,333	272,655
	11,250	7,054	78,409	1585,562	1625,201	23,776	16,885	15,059	272,064
	10,500	7,804	73,553	1487,361	1524,545	23,858	16,703	14,801	267,256
	9,750	8,554	68,528	1385,744	1420,388	23,960	16,504	14,550	1618,086
	9,000	9,304	60,126	1215,851	1246,247	24,290	16,350	14,140	1550,223
	8,250	10,054	51,889	1049,279	1075,511	24,708	16,164	13,729	1454,154

	7,500	10,804	43,908	887,895	910,092	25,244	15,941	13,319	1317,764
	6,750	11,554	35,602	719,934	737,932	25,883	15,720	12,876	1603,191
	6,000	12,304	27,218	550,387	564,147	26,691	15,511	12,380	1349,502
	5,250	13,054	19,622	396,789	406,709	27,797	15,289	11,855	1078,256
	4,500	13,804	13,198	266,878	273,550	29,172	15,060	11,300	784,345
	3,750	14,554	8,383	169,514	173,751	30,324	14,784	10,758	506,091
	3,000	15,304	4,825	97,573	100,012	31,496	14,498	10,208	294,548
	2,250	16,054	2,440	49,332	50,565	32,489	14,167	9,670	148,882
	1,521	16,783	1,000	20,222	20,727	33,321	13,781	9,161	60,257
	1,500	16,804	0,969	19,605	20,095	33,342	13,768	9,147	57,978
	0,750	17,554	0,203	4,106	4,209	34,053	13,192	8,644	12,980
	0,000	18,304	0,000	0,000	0,000	35,757	12,105	8,106	0,000

Tank Calibrations - doble casco 2 bab

Fluid Type = Water Ballast Specific gravity = 1,025

Permeability = 100 %

Trim = 0 m (+ve by stern); Heel = 0 deg to starboard

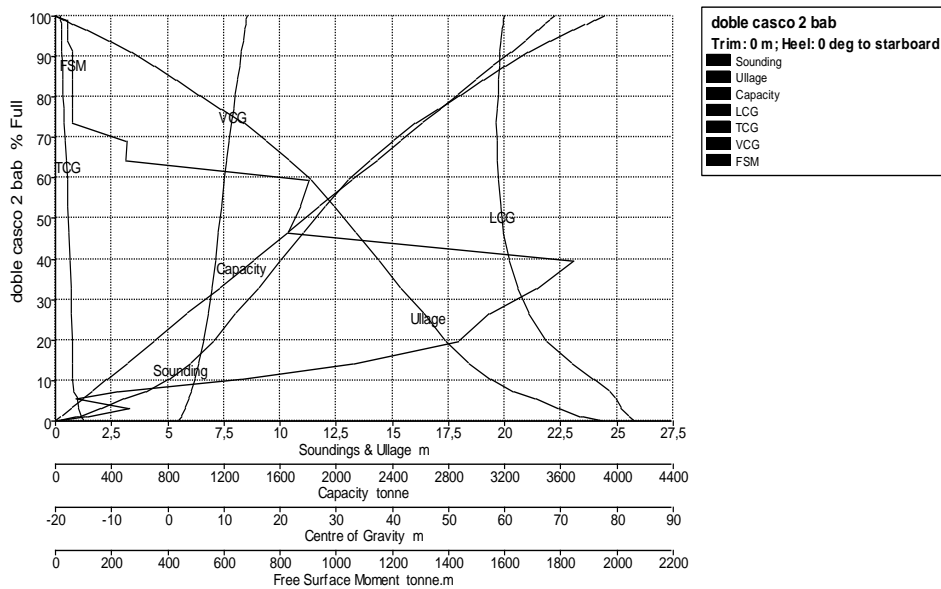

Tank Name	Sounding m	Ullage m	% Full	Capacity m ³	Capacity tonne	LCG m	TCG m	VCG m	FSM tonne.m
doble casco 2 bab	24,410	0,000	100,000	3470,398	3557,157	59,904	-19,056	14,147	0,000

	24,000	0,410	98,968	3434,589	3520,454	59,810	-19,036	14,021	42,613
	23,615	0,795	98,000	3400,990	3486,014	59,720	-19,018	13,905	42,613
	23,576	0,834	97,900	3397,519	3482,457	59,711	-19,016	13,893	42,613
	23,000	1,410	96,452	3347,251	3430,932	59,572	-18,987	13,722	42,613
	22,000	2,410	93,935	3259,913	3341,411	59,322	-18,935	13,433	42,613
	21,000	3,410	91,107	3161,787	3240,831	59,112	-18,874	13,122	59,871
	20,000	4,410	87,571	3039,077	3115,053	59,016	-18,791	12,743	59,871
	19,000	5,410	84,036	2916,367	2989,276	58,911	-18,702	12,374	59,871
	18,000	6,410	80,500	2793,657	2863,498	58,797	-18,604	12,018	59,871
	17,000	7,410	76,964	2670,949	2737,723	58,672	-18,498	11,674	59,848
	16,000	8,410	73,431	2548,355	2612,064	58,535	-18,381	11,345	59,444
	15,000	9,410	68,939	2392,453	2452,264	58,595	-18,251	10,945	256,266
	14,000	10,410	64,374	2234,018	2289,868	58,684	-18,104	10,551	251,324
	13,000	11,410	59,344	2059,477	2110,963	58,852	-17,946	10,135	904,011
	12,000	12,410	52,831	1833,454	1879,291	59,300	-17,785	9,597	873,213
	11,000	13,410	46,470	1612,679	1652,996	59,848	-17,593	9,062	831,036
	10,000	14,410	39,679	1377,035	1411,461	60,806	-17,428	8,476	1847,330
	9,000	15,410	32,778	1137,526	1165,965	62,309	-17,286	7,839	1712,532
	8,000	16,410	26,352	914,533	937,397	64,375	-17,139	7,188	1543,280
	7,000	17,410	19,684	683,118	700,196	67,626	-17,067	6,402	1434,394
	6,000	18,410	14,237	494,092	506,444	71,974	-17,076	5,589	1056,924
	5,000	19,410	10,281	356,793	365,713	76,020	-17,023	4,852	663,073
	4,000	20,410	7,230	250,910	257,182	78,750	-16,658	4,137	220,814
	3,000	21,410	5,544	192,387	197,196	79,829	-16,162	3,705	73,765
	2,000	22,410	3,235	112,278	115,085	80,806	-15,814	3,200	264,770
	1,000	23,410	1,132	39,287	40,270	82,185	-15,489	2,565	114,497
	0,914	23,496	1,000	34,704	35,571	82,292	-15,457	2,513	105,237
	0,000	24,410	0,000	0,000	0,000	83,405	-15,119	2,000	0,000

Tank Calibrations - doble casco 2 estrib

Fluid Type = Water Ballast Specific gravity = 1,025

Permeability = 100 %

Trim = 0 m (+ve by stern); Heel = 0 deg to starboard

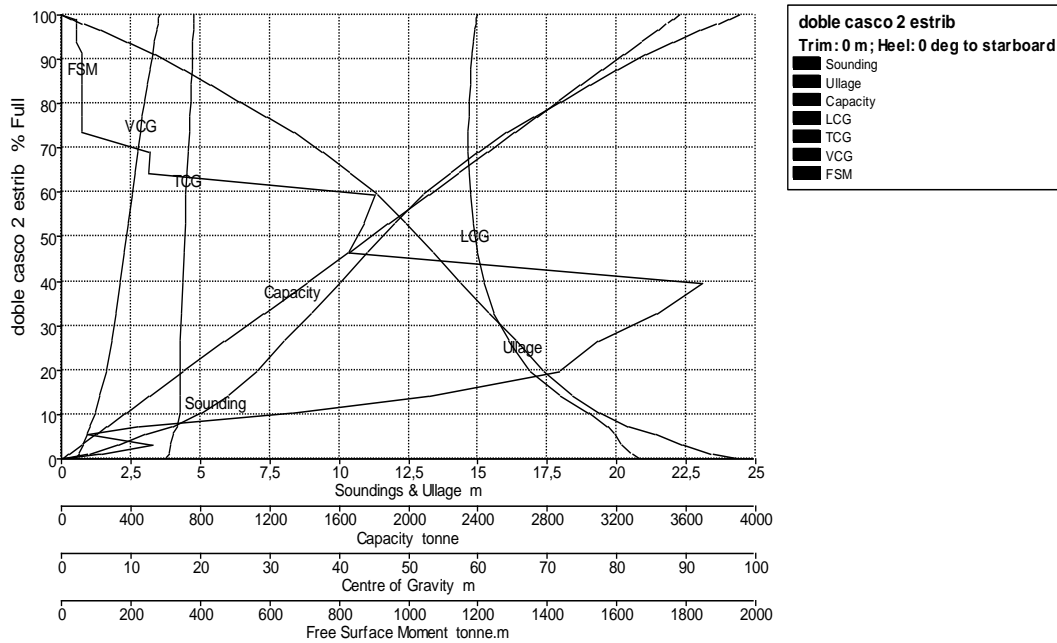

Tank Name	Sounding m	Ullage m	% Full	Capacity m ³	Capacity tonne	LCG m	TCG m	VCG m	FSM tonne.m
doble casco 2 estrib	24,410	0,000	100,000	3470,398	3557,157	59,904	19,056	14,147	0,000
	24,000	0,410	98,968	3434,589	3520,454	59,810	19,036	14,021	42,613
	23,615	0,795	98,000	3400,990	3486,014	59,720	19,018	13,905	42,613
	23,576	0,834	97,900	3397,519	3482,457	59,711	19,016	13,893	42,613
	23,000	1,410	96,452	3347,251	3430,932	59,572	18,987	13,722	42,613
	22,000	2,410	93,935	3259,913	3341,411	59,322	18,935	13,433	42,613
	21,000	3,410	91,107	3161,787	3240,831	59,112	18,874	13,122	59,871
	20,000	4,410	87,571	3039,077	3115,053	59,016	18,791	12,743	59,871
	19,000	5,410	84,036	2916,367	2989,276	58,911	18,702	12,374	59,871
	18,000	6,410	80,500	2793,657	2863,498	58,797	18,604	12,018	59,871
	17,000	7,410	76,964	2670,949	2737,723	58,672	18,498	11,674	59,848
	16,000	8,410	73,431	2548,355	2612,064	58,535	18,381	11,345	59,444
	15,000	9,410	68,939	2392,453	2452,264	58,595	18,251	10,945	256,266
	14,000	10,410	64,374	2234,018	2289,868	58,684	18,104	10,551	251,324
	13,000	11,410	59,344	2059,477	2110,963	58,852	17,946	10,135	904,011
	12,000	12,410	52,831	1833,454	1879,291	59,300	17,785	9,597	873,213

	11,000	13,410	46,470	1612,679	1652,996	59,848	17,593	9,062	831,036
	10,000	14,410	39,679	1377,035	1411,461	60,806	17,428	8,476	1847,330
	9,000	15,410	32,778	1137,526	1165,965	62,309	17,286	7,839	1712,532
	8,000	16,410	26,352	914,533	937,397	64,375	17,139	7,188	1543,280
	7,000	17,410	19,684	683,118	700,196	67,626	17,067	6,402	1434,394
	6,000	18,410	14,237	494,092	506,444	71,974	17,076	5,589	1056,924
	5,000	19,410	10,281	356,793	365,713	76,020	17,023	4,852	663,073
	4,000	20,410	7,230	250,910	257,182	78,750	16,658	4,137	220,814
	3,000	21,410	5,544	192,387	197,196	79,829	16,162	3,705	73,765
	2,000	22,410	3,235	112,278	115,085	80,806	15,814	3,200	264,770
	1,000	23,410	1,132	39,287	40,270	82,185	15,489	2,565	114,497
	0,914	23,496	1,000	34,704	35,571	82,292	15,457	2,513	105,237
	0,000	24,410	0,000	0,000	0,000	83,405	15,119	2,000	0,000

Tank Calibrations - doble casco 3 bab

Fluid Type = Water Ballast Specific gravity = 1,025

Permeability = 100 %

Trim = 0 m (+ve by stern); Heel = 0 deg to starboard

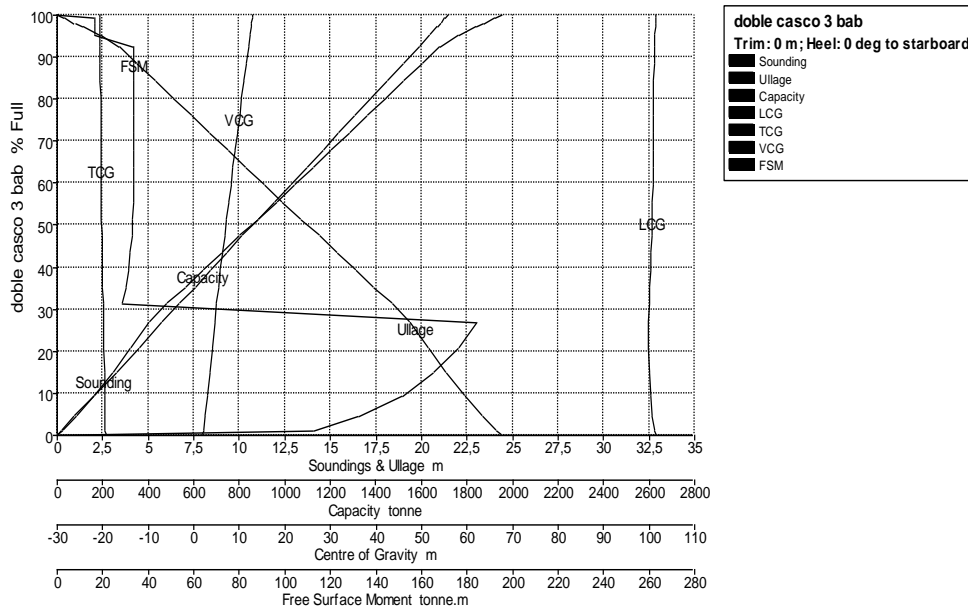

Tank Name	Sounding m	Ullage m	% Full	Capacity m ³	Capacity tonne	LCG m	TCG m	VCG m	FSM tonne.m
doble casco 3	24,410	0,000	100,000	1674,799	1716,669	101,595	-20,590	12,947	0,000

bab									
	24,000	0,410	99,177	1661,021	1702,547	101,533	-20,587	12,837	16,395
	23,413	0,997	98,000	1641,303	1682,335	101,443	-20,583	12,683	16,395
	23,363	1,047	97,900	1639,628	1680,619	101,436	-20,583	12,670	16,395
	23,000	1,410	97,171	1627,418	1668,103	101,379	-20,580	12,576	16,395
	22,000	2,410	95,165	1593,815	1633,660	101,218	-20,573	12,324	16,395
	21,000	3,410	92,514	1549,423	1588,158	101,095	-20,563	12,007	33,654
	20,000	4,410	88,396	1480,447	1517,459	101,071	-20,546	11,518	33,654
	19,000	5,410	84,277	1411,472	1446,759	101,045	-20,528	11,030	33,654
	18,000	6,410	80,159	1342,497	1376,059	101,016	-20,508	10,543	33,654
	17,000	7,410	76,040	1273,521	1305,359	100,984	-20,486	10,058	33,654
	16,000	8,410	71,922	1204,546	1234,659	100,948	-20,461	9,575	33,654
	15,000	9,410	67,803	1135,570	1163,960	100,907	-20,433	9,093	33,653
	14,000	10,410	63,685	1066,597	1093,262	100,862	-20,401	8,615	33,646
	13,000	11,410	59,568	997,643	1022,584	100,810	-20,365	8,139	33,592
	12,000	12,410	55,455	928,753	951,971	100,750	-20,324	7,667	33,444
	11,000	13,410	51,350	860,002	881,502	100,679	-20,277	7,200	33,192
	10,000	14,410	47,259	791,490	811,277	100,595	-20,222	6,742	32,755
	9,000	15,410	43,190	723,339	741,423	100,492	-20,158	6,293	32,173
	8,000	16,410	39,152	655,721	672,114	100,362	-20,081	5,859	31,314
	7,000	17,410	35,159	588,842	603,563	100,198	-19,990	5,446	30,231
	6,000	18,410	31,228	523,006	536,081	99,981	-19,880	5,061	28,792
	5,000	19,410	26,709	447,317	458,500	99,817	-19,777	4,657	184,303
	4,000	20,410	20,740	347,350	356,033	99,941	-19,734	4,126	176,229
	3,000	21,410	14,945	250,302	256,560	100,109	-19,679	3,592	165,269
	2,000	22,410	9,415	157,678	161,620	100,352	-19,608	3,056	151,075
	1,000	23,410	4,317	72,305	74,112	100,731	-19,517	2,520	132,122
	0,256	24,154	1,000	16,748	17,167	101,185	-19,437	2,130	112,358
	0,000	24,410	0,000	0,000	0,000	101,384	-19,407	2,000	0,000

Tank Calibrations - doble casco 3 estrib

Fluid Type = Water Ballast Specific gravity = 1,025

Permeability = 100 %

Trim = 0 m (+ve by stern); Heel = 0 deg to starboard

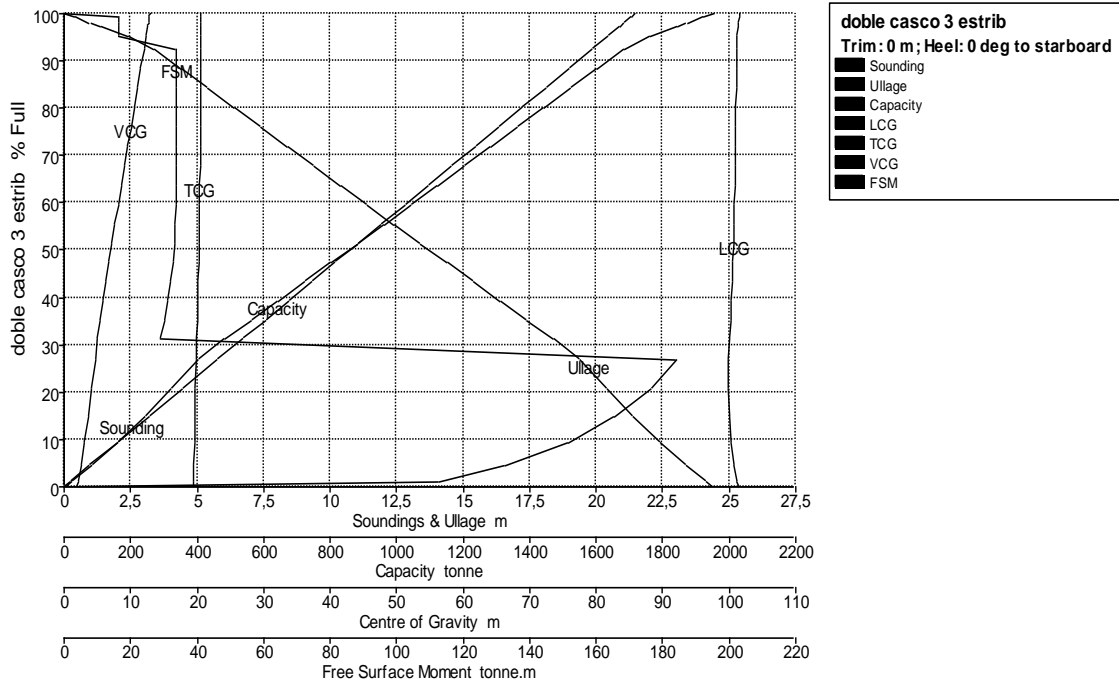

Tank Name	Sounding m	Ullage m	% Full	Capacity m ³	Capacity tonne	LCG m	TCG m	VCG m	FSM tonne.m
doble casco 3 estrib	24,410	0,000	100,000	1674,799	1716,669	101,595	20,590	12,947	0,000
	24,000	0,410	99,177	1661,021	1702,547	101,533	20,587	12,837	16,395
	23,413	0,997	98,000	1641,303	1682,335	101,443	20,583	12,683	16,395
	23,363	1,047	97,900	1639,628	1680,619	101,436	20,583	12,670	16,395
	23,000	1,410	97,171	1627,418	1668,103	101,379	20,580	12,576	16,395
	22,000	2,410	95,165	1593,815	1633,660	101,218	20,573	12,324	16,395
	21,000	3,410	92,514	1549,423	1588,158	101,095	20,563	12,007	33,654
	20,000	4,410	88,396	1480,447	1517,459	101,071	20,546	11,518	33,654
	19,000	5,410	84,277	1411,472	1446,759	101,045	20,528	11,030	33,654
	18,000	6,410	80,159	1342,497	1376,059	101,016	20,508	10,543	33,654
	17,000	7,410	76,040	1273,521	1305,359	100,984	20,486	10,058	33,654
	16,000	8,410	71,922	1204,546	1234,659	100,948	20,461	9,575	33,654
	15,000	9,410	67,803	1135,570	1163,960	100,907	20,433	9,093	33,653
	14,000	10,410	63,685	1066,597	1093,262	100,862	20,401	8,615	33,646
	13,000	11,410	59,568	997,643	1022,584	100,810	20,365	8,139	33,592

	12,000	12,410	55,455	928,753	951,971	100,750	20,324	7,667	33,444
	11,000	13,410	51,350	860,002	881,502	100,679	20,277	7,200	33,192
	10,000	14,410	47,259	791,490	811,277	100,595	20,222	6,742	32,755
	9,000	15,410	43,190	723,339	741,423	100,492	20,158	6,293	32,173
	8,000	16,410	39,152	655,721	672,114	100,362	20,081	5,859	31,314
	7,000	17,410	35,159	588,842	603,563	100,198	19,990	5,446	30,231
	6,000	18,410	31,228	523,006	536,081	99,981	19,880	5,061	28,792
	5,000	19,410	26,709	447,317	458,500	99,817	19,777	4,657	184,303
	4,000	20,410	20,740	347,350	356,033	99,941	19,734	4,126	176,229
	3,000	21,410	14,945	250,302	256,560	100,109	19,679	3,592	165,269
	2,000	22,410	9,415	157,678	161,620	100,352	19,608	3,056	151,075
	1,000	23,410	4,317	72,305	74,112	100,731	19,517	2,520	132,122
	0,256	24,154	1,000	16,748	17,167	101,185	19,437	2,130	112,358
	0,000	24,410	0,000	0,000	0,000	101,384	19,407	2,000	0,000

Tank Calibrations - doble casco 4 bab

Fluid Type = Water Ballast Specific gravity = 1,025

Permeability = 100 %

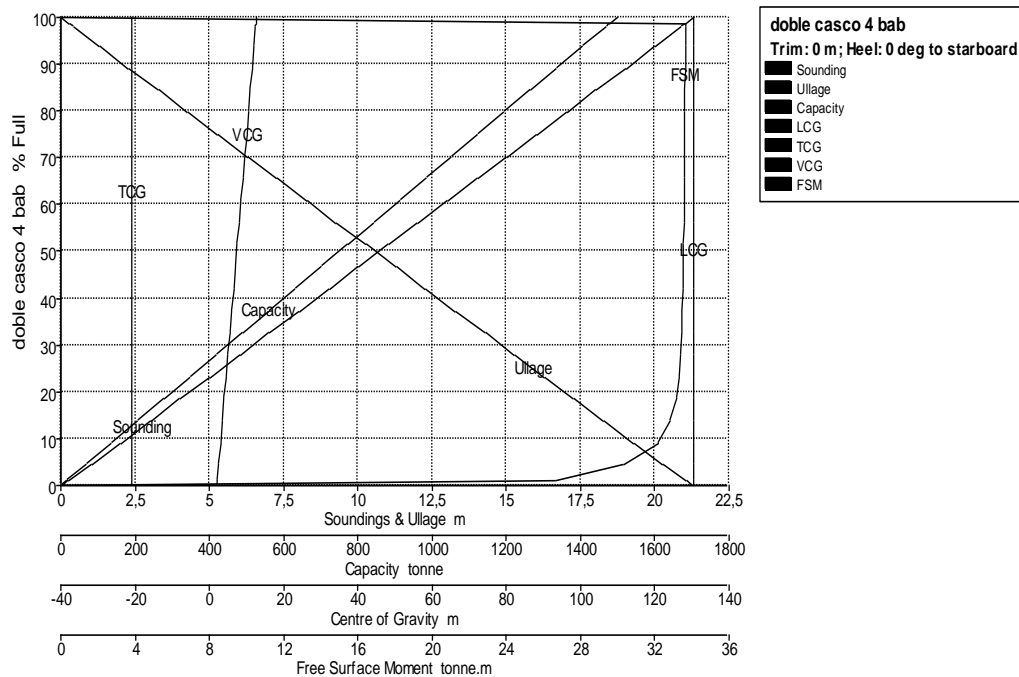

Trim = 0 m (+ve by stern); Heel = 0 deg to starboard

Tank Name	Sounding m	Ullage m	% Full	Capacity m ³	Capacity tonne	LCG m	TCG m	VCG m	FSM tonne.m
doble casco 4 bab	21,305	0,000	100,000	1461,116	1497,644	130,472	-20,913	12,700	0,000
	21,000	0,305	98,560	1440,080	1476,082	130,472	-20,913	12,548	33,643
	20,881	0,424	98,000	1431,894	1467,691	130,472	-20,913	12,488	33,643
	20,860	0,445	97,900	1430,432	1466,193	130,472	-20,913	12,478	33,643
	20,000	1,305	93,840	1371,114	1405,391	130,472	-20,913	12,047	33,638
	19,000	2,305	89,120	1302,151	1334,705	130,472	-20,913	11,546	33,631
	18,000	3,305	84,401	1233,194	1264,024	130,472	-20,912	11,046	33,623
	17,000	4,305	79,682	1164,243	1193,349	130,473	-20,912	10,545	33,613
	16,000	5,305	74,963	1095,299	1122,681	130,473	-20,911	10,044	33,602
	15,000	6,305	70,245	1026,363	1052,022	130,474	-20,911	9,544	33,590
	14,000	7,305	65,528	957,435	981,371	130,475	-20,910	9,043	33,580
	13,000	8,305	60,811	888,513	910,726	130,476	-20,909	8,542	33,572
	12,000	9,305	56,094	819,597	840,087	130,477	-20,909	8,041	33,562
	11,000	10,305	51,378	750,688	769,455	130,478	-20,908	7,540	33,550
	10,000	11,305	46,662	681,789	698,833	130,480	-20,907	7,039	33,536
	9,000	12,305	41,947	612,901	628,223	130,482	-20,905	6,537	33,515
	8,000	13,305	37,234	544,030	557,631	130,485	-20,904	6,035	33,488
	7,000	14,305	32,522	475,179	487,058	130,488	-20,902	5,533	33,452
	6,000	15,305	27,812	406,360	416,519	130,492	-20,899	5,031	33,398
	5,000	16,305	23,104	337,581	346,020	130,496	-20,895	4,528	33,321
	4,000	17,305	18,403	268,896	275,618	130,502	-20,890	4,024	33,142
	3,000	18,305	13,712	200,351	205,360	130,509	-20,883	3,519	32,818
	2,000	19,305	9,047	132,183	135,487	130,517	-20,871	3,013	32,164
	1,000	20,305	4,438	64,851	66,472	130,524	-20,849	2,506	30,285
	0,232	21,073	1,000	14,611	14,976	130,520	-20,818	2,116	26,588
	0,000	21,305	0,000	0,000	0,000	130,506	-20,802	2,000	0,000

Tank Calibrations - doble casco 4 estrib

Fluid Type = Water Ballast Specific gravity = 1,025

Permeability = 100 %

Trim = 0 m (+ve by stern); Heel = 0 deg to starboard

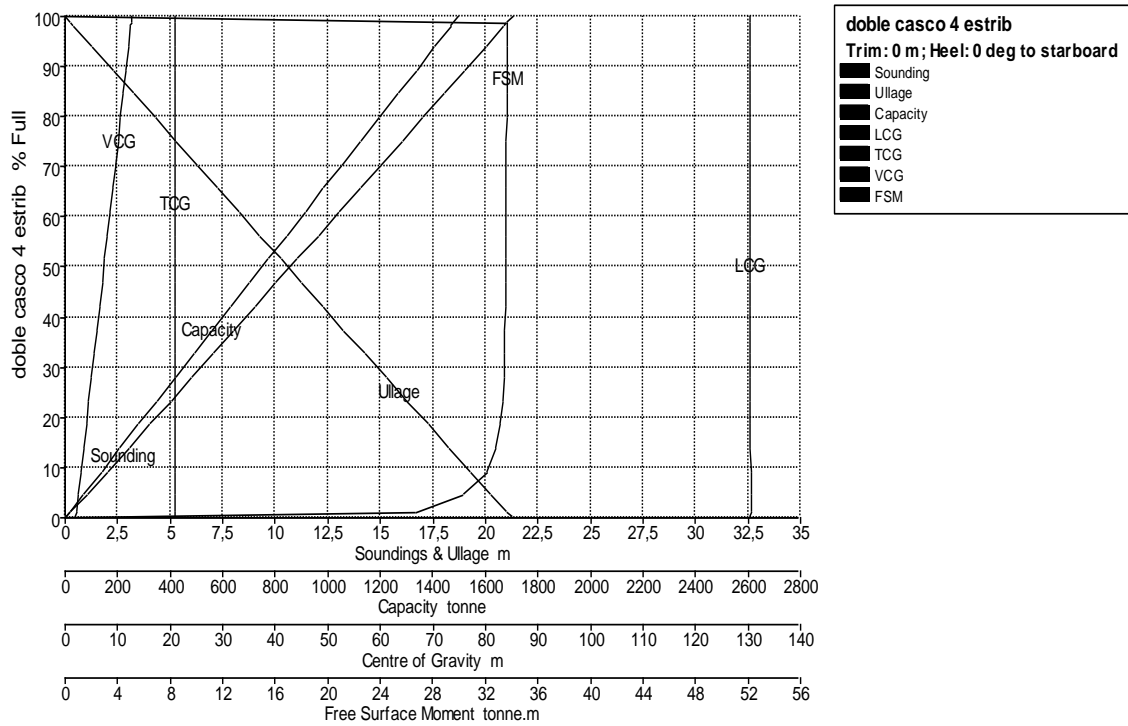

Tank Name	Sounding m	Ullage m	% Full	Capacity m ³	Capacity tonne	LCG m	TCG m	VCG m	FSM tonne.m
doble casco 4 estrib	21,305	0,000	100,000	1461,116	1497,644	130,472	20,913	12,700	0,000
	21,000	0,305	98,560	1440,080	1476,082	130,472	20,913	12,548	33,643
	20,881	0,424	98,000	1431,894	1467,691	130,472	20,913	12,488	33,643
	20,860	0,445	97,900	1430,432	1466,193	130,472	20,913	12,478	33,643
	20,000	1,305	93,840	1371,114	1405,391	130,472	20,913	12,047	33,638
	19,000	2,305	89,120	1302,151	1334,705	130,472	20,913	11,546	33,631
	18,000	3,305	84,401	1233,194	1264,024	130,472	20,912	11,046	33,623
	17,000	4,305	79,682	1164,243	1193,349	130,473	20,912	10,545	33,613
	16,000	5,305	74,963	1095,299	1122,681	130,473	20,911	10,044	33,602
	15,000	6,305	70,245	1026,363	1052,022	130,474	20,911	9,544	33,590
	14,000	7,305	65,528	957,435	981,371	130,475	20,910	9,043	33,580
	13,000	8,305	60,811	888,513	910,726	130,476	20,909	8,542	33,572
	12,000	9,305	56,094	819,597	840,087	130,477	20,909	8,041	33,562
	11,000	10,305	51,378	750,688	769,455	130,478	20,908	7,540	33,550
	10,000	11,305	46,662	681,789	698,833	130,480	20,907	7,039	33,536

	9,000	12,305	41,947	612,901	628,223	130,482	20,905	6,537	33,515
	8,000	13,305	37,234	544,030	557,631	130,485	20,904	6,035	33,488
	7,000	14,305	32,522	475,179	487,058	130,488	20,902	5,533	33,452
	6,000	15,305	27,812	406,360	416,519	130,492	20,899	5,031	33,398
	5,000	16,305	23,104	337,581	346,020	130,496	20,895	4,528	33,321
	4,000	17,305	18,403	268,896	275,618	130,502	20,890	4,024	33,142
	3,000	18,305	13,712	200,351	205,360	130,509	20,883	3,519	32,818
	2,000	19,305	9,047	132,183	135,487	130,517	20,871	3,013	32,164
	1,000	20,305	4,438	64,851	66,472	130,524	20,849	2,506	30,285
	0,232	21,073	1,000	14,611	14,976	130,520	20,818	2,116	26,588
	0,000	21,305	0,000	0,000	0,000	130,506	20,802	2,000	0,000

Tank Calibrations - doble casco 5 bab

Fluid Type = Water Ballast Specific gravity = 1,025

Permeability = 100 %

Trim = 0 m (+ve by stern); Heel = 0 deg to starboard

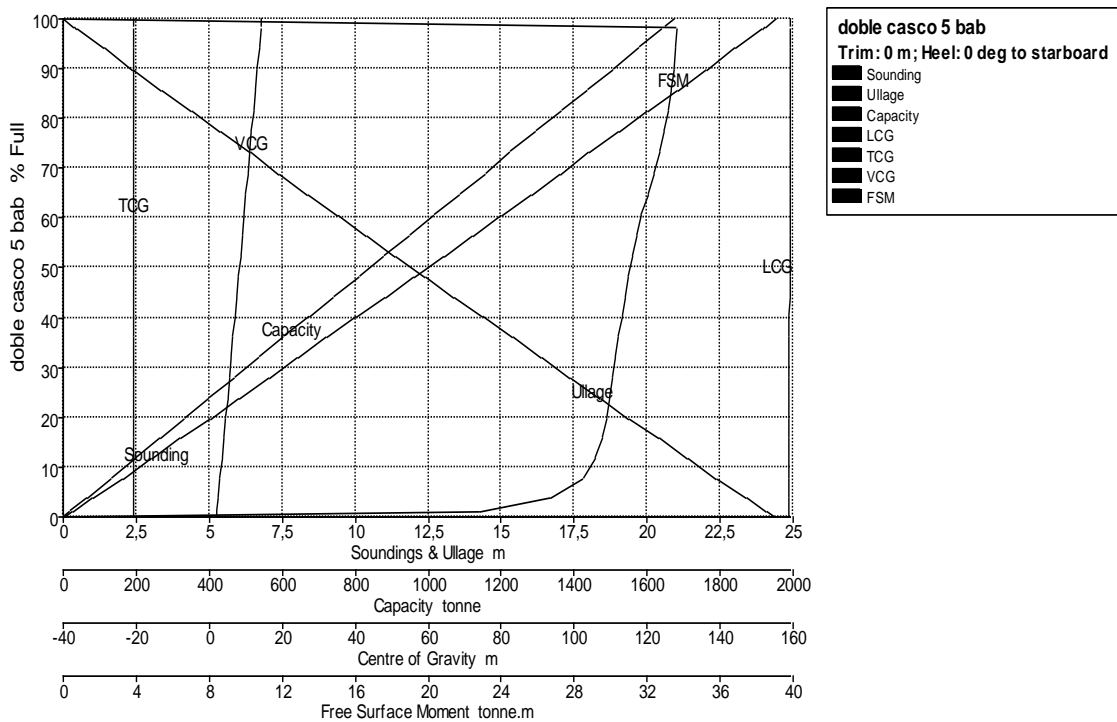

Tank Name	Sounding m	Ullage m	% Full	Capacity m ³	Capacity tonne	LCG m	TCG m	VCG m	FSM tonne.m
doble casco 5 bab	24,410	0,000	100,000	1633,936	1674,784	159,147	-20,886	14,369	0,000
	24,000	0,410	98,269	1605,659	1645,801	159,143	-20,886	14,160	33,629
	23,936	0,474	98,000	1601,257	1641,288	159,143	-20,886	14,128	33,625
	23,912	0,498	97,900	1599,623	1639,613	159,143	-20,886	14,116	33,623
	23,000	1,410	94,050	1536,722	1575,140	159,135	-20,884	13,652	33,568
	22,000	2,410	89,834	1467,838	1504,534	159,127	-20,883	13,143	33,455
	21,000	3,410	85,624	1399,047	1434,023	159,117	-20,881	12,633	33,317
	20,000	4,410	81,421	1330,364	1363,624	159,108	-20,879	12,124	33,131
	19,000	5,410	77,226	1261,821	1293,367	159,098	-20,878	11,615	32,927
	18,000	6,410	73,041	1193,444	1223,280	159,088	-20,876	11,105	32,667
	17,000	7,410	68,868	1125,264	1153,395	159,078	-20,874	10,597	32,366
	16,000	8,410	64,710	1057,319	1083,752	159,069	-20,872	10,089	32,027
	15,000	9,410	60,567	989,632	1014,373	159,060	-20,870	9,582	31,685
	14,000	10,410	56,440	922,186	945,241	159,051	-20,868	9,076	31,395
	13,000	11,410	52,324	854,938	876,312	159,043	-20,867	8,571	31,167
	12,000	12,410	48,218	787,858	807,555	159,034	-20,865	8,066	30,969
	11,000	13,410	44,122	720,928	738,952	159,026	-20,863	7,561	30,785
	10,000	14,410	40,035	654,139	670,493	159,018	-20,861	7,057	30,614
	9,000	15,410	35,955	587,488	602,175	159,009	-20,859	6,553	30,447
	8,000	16,410	31,884	520,971	533,995	159,000	-20,856	6,049	30,284
	7,000	17,410	27,822	454,587	465,952	158,990	-20,853	5,545	30,121
	6,000	18,410	23,767	388,343	398,051	158,979	-20,850	5,041	29,953
	5,000	19,410	19,722	322,240	330,296	158,967	-20,845	4,537	29,779
	4,000	20,410	15,687	256,319	262,727	158,952	-20,839	4,031	29,518
	3,000	21,410	11,667	190,624	195,390	158,934	-20,830	3,525	29,154
	2,000	22,410	7,673	125,378	128,512	158,907	-20,815	3,018	28,480
	1,000	23,410	3,739	61,090	62,617	158,859	-20,788	2,508	26,607
	0,278	24,132	1,000	16,339	16,748	158,786	-20,748	2,140	22,793
	0,000	24,410	0,000	0,000	0,000	158,764	-20,723	2,000	0,000

Tank Calibrations - doble casco 5 estrib

Fluid Type = Water Ballast Specific gravity = 1,025

Permeability = 100 %

Trim = 0 m (+ve by stern); Heel = 0 deg to starboard

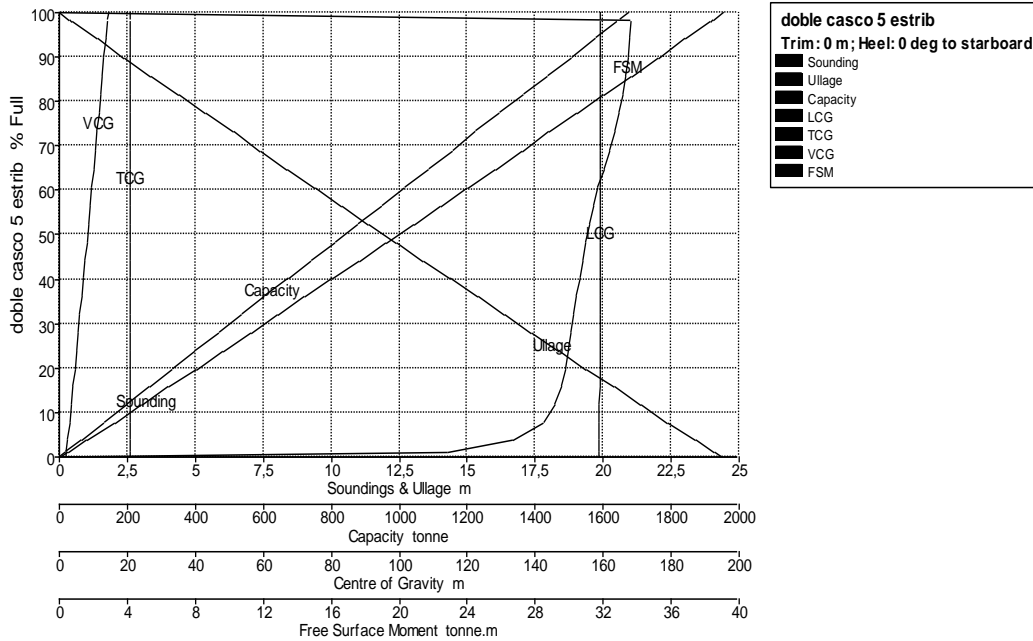

Tank Name	Sounding m	Ullage m	% Full	Capacity m ³	Capacity tonne	LCG m	TCG m	VCG m	FSM tonne.m
doble casco 5 estrib	24,410	0,000	100,000	1633,936	1674,784	159,147	20,886	14,369	0,000
	24,000	0,410	98,269	1605,659	1645,801	159,143	20,886	14,160	33,629
	23,936	0,474	98,000	1601,257	1641,288	159,143	20,886	14,128	33,625
	23,912	0,498	97,900	1599,623	1639,613	159,143	20,886	14,116	33,623
	23,000	1,410	94,050	1536,722	1575,140	159,135	20,884	13,652	33,568
	22,000	2,410	89,834	1467,838	1504,534	159,127	20,883	13,143	33,455
	21,000	3,410	85,624	1399,047	1434,023	159,117	20,881	12,633	33,317
	20,000	4,410	81,421	1330,364	1363,624	159,108	20,879	12,124	33,131
	19,000	5,410	77,226	1261,821	1293,367	159,098	20,878	11,615	32,927
	18,000	6,410	73,041	1193,444	1223,280	159,088	20,876	11,105	32,667
	17,000	7,410	68,868	1125,264	1153,395	159,078	20,874	10,597	32,366
	16,000	8,410	64,710	1057,319	1083,752	159,069	20,872	10,089	32,027
	15,000	9,410	60,567	989,632	1014,373	159,060	20,870	9,582	31,685

	14,000	10,410	56,440	922,186	945,241	159,051	20,868	9,076	31,395
	13,000	11,410	52,324	854,938	876,312	159,043	20,867	8,571	31,167
	12,000	12,410	48,218	787,858	807,555	159,034	20,865	8,066	30,969
	11,000	13,410	44,122	720,928	738,952	159,026	20,863	7,561	30,785
	10,000	14,410	40,035	654,139	670,493	159,018	20,861	7,057	30,614
	9,000	15,410	35,955	587,488	602,175	159,009	20,859	6,553	30,447
	8,000	16,410	31,884	520,971	533,995	159,000	20,856	6,049	30,284
	7,000	17,410	27,822	454,587	465,952	158,990	20,853	5,545	30,121
	6,000	18,410	23,767	388,343	398,051	158,979	20,850	5,041	29,953
	5,000	19,410	19,722	322,240	330,296	158,967	20,845	4,537	29,779
	4,000	20,410	15,687	256,319	262,727	158,952	20,839	4,031	29,518
	3,000	21,410	11,667	190,624	195,390	158,934	20,830	3,525	29,154
	2,000	22,410	7,673	125,378	128,512	158,907	20,815	3,018	28,480
	1,000	23,410	3,739	61,090	62,617	158,859	20,788	2,508	26,607
	0,278	24,132	1,000	16,339	16,748	158,786	20,748	2,140	22,793
	0,000	24,410	0,000	0,000	0,000	158,764	20,723	2,000	0,000

Tank Calibrations - doble casco 6 bab

Fluid Type = Water Ballast Specific gravity = 1,025

Permeability = 100 %

Trim = 0 m (+ve by stern); Heel = 0 deg to starboard

Tank Name	Sounding m	Ullage m	% Full	Capacity m ³	Capacity tonne	LCG m	TCG m	VCG m	FSM tonne.m
doble casco 6 bab	21,305	0,000	100,000	1567,128	1606,306	189,553	-20,096	12,263	0,000
	21,000	0,305	98,689	1546,581	1585,245	189,572	-20,085	12,118	31,238
	20,839	0,466	98,000	1535,785	1574,180	189,583	-20,079	12,042	31,079
	20,816	0,489	97,900	1534,218	1572,574	189,584	-20,078	12,031	31,051
	20,000	1,305	94,426	1479,773	1516,768	189,641	-20,049	11,650	29,984
	19,000	2,305	90,226	1413,954	1449,302	189,717	-20,011	11,191	28,676
	18,000	3,305	86,101	1349,314	1383,047	189,804	-19,971	10,745	27,115
	17,000	4,305	82,064	1286,045	1318,196	189,901	-19,929	10,314	25,404
	16,000	5,305	78,130	1224,397	1255,007	190,011	-19,885	9,902	23,601

	15,000	6,305	74,310	1164,529	1193,642	190,135	-19,840	9,511	21,872
	14,000	7,305	70,599	1106,379	1134,039	190,277	-19,792	9,144	20,459
	13,000	8,305	66,472	1041,706	1067,749	190,391	-19,752	8,752	142,912
	12,000	9,305	60,896	954,319	978,177	190,377	-19,741	8,225	139,623
	11,000	10,305	55,391	868,054	889,755	190,363	-19,729	7,701	136,623
	10,000	11,305	49,954	782,840	802,411	190,348	-19,717	7,179	133,884
	9,000	12,305	44,582	698,651	716,118	190,333	-19,705	6,658	131,259
	8,000	13,305	39,273	615,465	630,852	190,318	-19,692	6,138	128,747
	7,000	14,305	34,029	533,280	546,612	190,301	-19,678	5,620	126,277
	6,000	15,305	28,850	452,114	463,416	190,284	-19,663	5,103	123,842
	5,000	16,305	23,737	371,987	381,287	190,265	-19,645	4,586	121,342
	4,000	17,305	18,696	292,994	300,318	190,244	-19,624	4,070	118,699
	3,000	18,305	13,737	215,277	220,659	190,219	-19,596	3,553	115,479
	2,000	19,305	8,885	139,235	142,716	190,190	-19,556	3,034	111,189
	1,000	20,305	4,216	66,069	67,721	190,158	-19,487	2,514	102,485
	0,254	21,051	1,000	15,671	16,063	190,170	-19,397	2,128	87,557
	0,000	21,305	0,000	0,000	0,000	190,190	-19,355	2,000	0,000

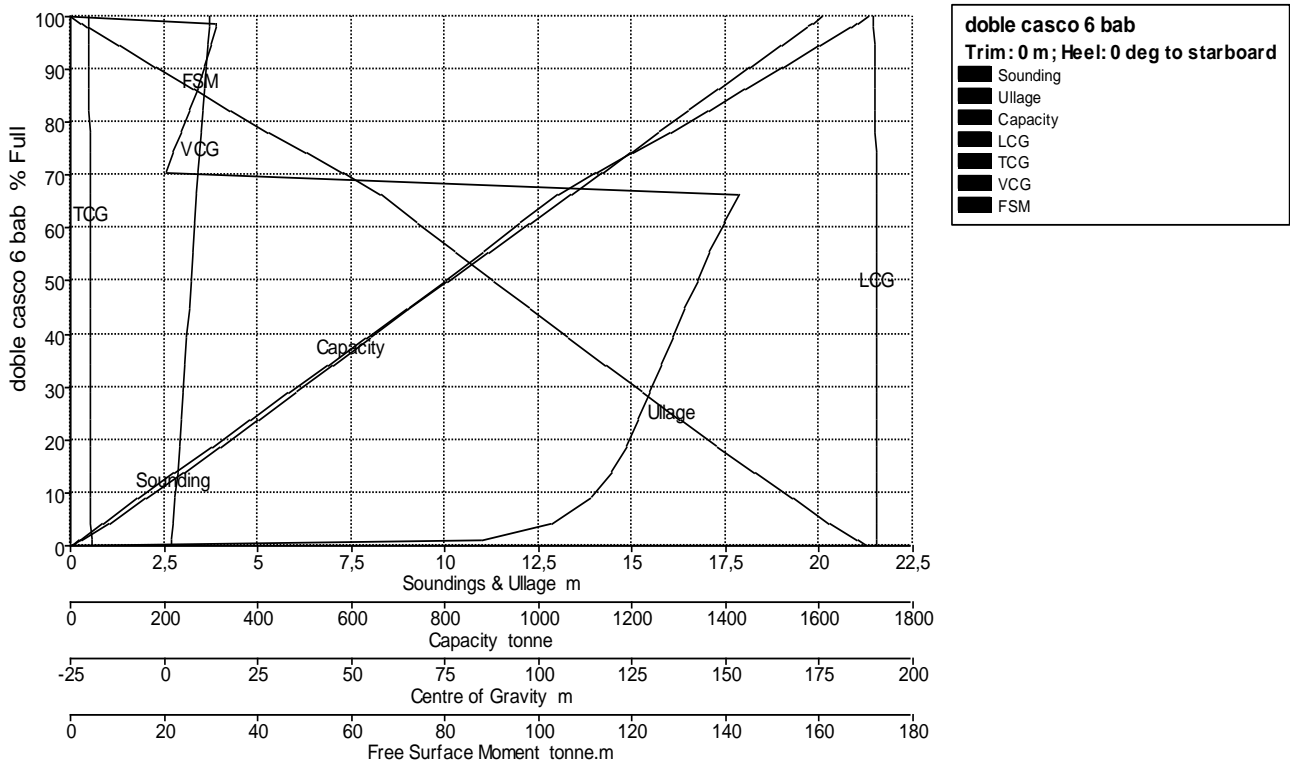

Tank Calibrations - doble casco 6 estrib

Fluid Type = Water Ballast Specific gravity = 1,025

Permeability = 100 %

Trim = 0 m (+ve by stern); Heel = 0 deg to starboard

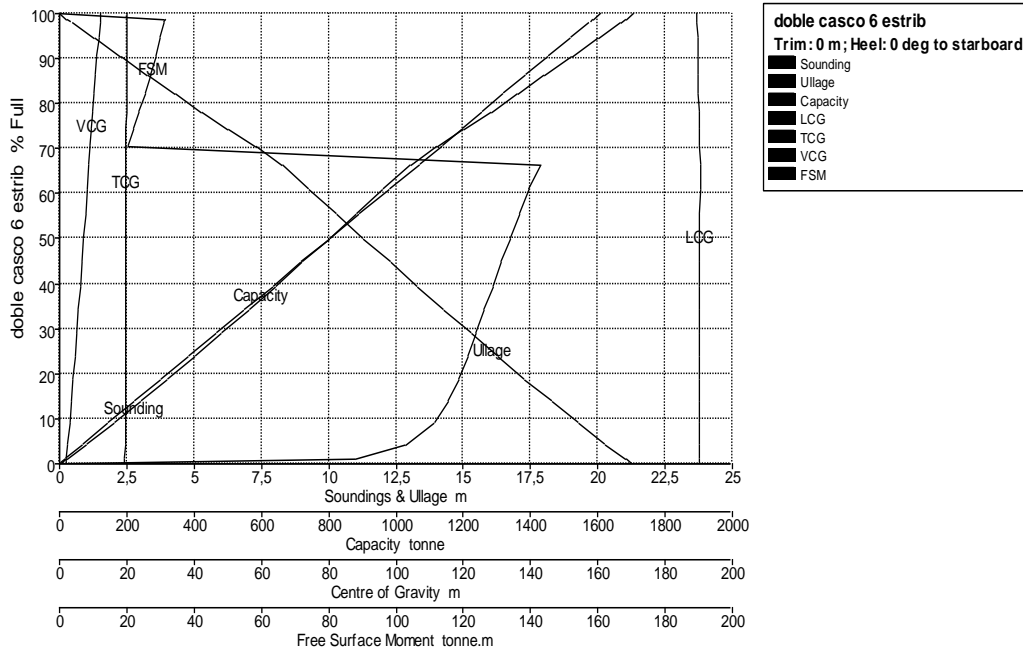

Tank Name	Sounding m	Ullage m	% Full	Capacity m ³	Capacity tonne	LCG m	TCG m	VCG m	FSM tonne.m
doble casco 6 estrib	21,305	0,000	100,000	1567,128	1606,306	189,553	20,096	12,263	0,000
	21,000	0,305	98,689	1546,581	1585,245	189,572	20,085	12,118	31,238
	20,839	0,466	98,000	1535,785	1574,180	189,583	20,079	12,042	31,079
	20,816	0,489	97,900	1534,218	1572,574	189,584	20,078	12,031	31,051
	20,000	1,305	94,426	1479,773	1516,768	189,641	20,049	11,650	29,984
	19,000	2,305	90,226	1413,954	1449,302	189,717	20,011	11,191	28,676
	18,000	3,305	86,101	1349,314	1383,047	189,804	19,971	10,745	27,115
	17,000	4,305	82,064	1286,045	1318,196	189,901	19,929	10,314	25,404
	16,000	5,305	78,130	1224,397	1255,007	190,011	19,885	9,902	23,601
	15,000	6,305	74,310	1164,529	1193,642	190,135	19,840	9,511	21,872
	14,000	7,305	70,599	1106,379	1134,039	190,277	19,792	9,144	20,459
	13,000	8,305	66,472	1041,706	1067,749	190,391	19,752	8,752	142,912
	12,000	9,305	60,896	954,319	978,177	190,377	19,741	8,225	139,623
	11,000	10,305	55,391	868,054	889,755	190,363	19,729	7,701	136,623

	10,000	11,305	49,954	782,840	802,411	190,348	19,717	7,179	133,884
	9,000	12,305	44,582	698,651	716,118	190,333	19,705	6,658	131,259
	8,000	13,305	39,273	615,465	630,852	190,318	19,692	6,138	128,747
	7,000	14,305	34,029	533,280	546,612	190,301	19,678	5,620	126,277
	6,000	15,305	28,850	452,114	463,416	190,284	19,663	5,103	123,842
	5,000	16,305	23,737	371,987	381,287	190,265	19,645	4,586	121,342
	4,000	17,305	18,696	292,994	300,318	190,244	19,624	4,070	118,699
	3,000	18,305	13,737	215,277	220,659	190,219	19,596	3,553	115,479
	2,000	19,305	8,885	139,235	142,716	190,190	19,556	3,034	111,189
	1,000	20,305	4,216	66,069	67,721	190,158	19,487	2,514	102,485
	0,254	21,051	1,000	15,671	16,063	190,170	19,397	2,128	87,557
	0,000	21,305	0,000	0,000	0,000	190,190	19,355	2,000	0,000

Tank Calibrations - doble casco 7 bab

Fluid Type = Water Ballast Specific gravity = 1,025

Permeability = 100 %

Trim = 0 m (+ve by stern); Heel = 0 deg to starboard

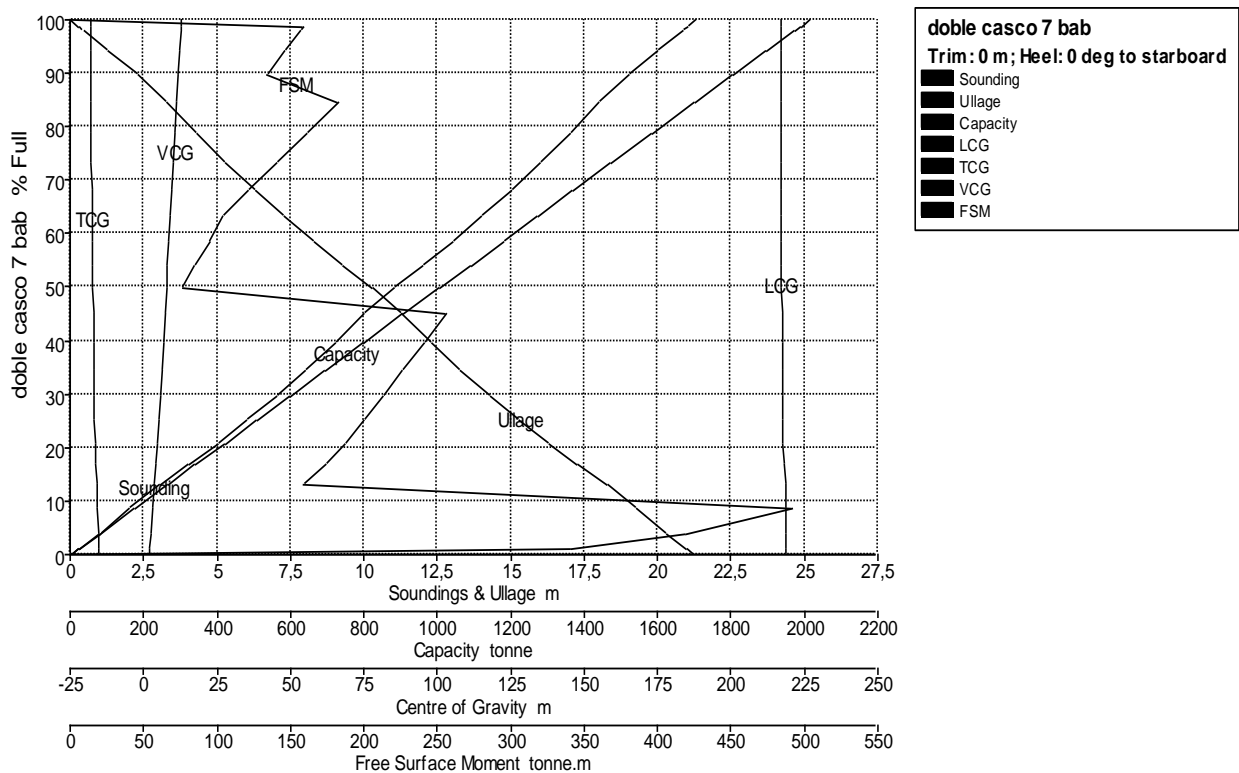

Tank Name	Sounding m	Ullage m	% Full	Capacity m ³	Capacity tonne	LCG m	TCG m	VCG m	FSM tonne.m
doble casco 7 bab	21,305	0,000	100,000	1963,230	2012,311	217,225	-18,246	13,010	0,000
	21,000	0,305	98,715	1937,998	1986,448	217,204	-18,221	12,878	158,888
	20,849	0,456	98,000	1923,965	1972,065	217,187	-18,208	12,805	156,971
	20,828	0,477	97,900	1922,002	1970,052	217,184	-18,206	12,795	156,695
	20,000	1,305	94,064	1846,689	1892,857	217,088	-18,135	12,402	146,291
	19,000	2,305	89,612	1759,289	1803,271	216,967	-18,049	11,950	133,855
	18,000	3,305	84,392	1656,802	1698,222	216,900	-17,957	11,424	182,175
	17,000	4,305	78,610	1543,288	1581,870	216,886	-17,858	10,829	161,106
	16,000	5,305	73,120	1435,510	1471,398	216,881	-17,757	10,253	140,353
	15,000	6,305	67,951	1334,037	1367,388	216,887	-17,655	9,701	120,779
	14,000	7,305	63,117	1239,137	1270,115	216,911	-17,552	9,180	104,098
	13,000	8,305	58,535	1149,178	1177,907	216,972	-17,448	8,685	95,134
	12,000	9,305	54,036	1060,845	1087,366	217,116	-17,336	8,201	84,796
	11,000	10,305	49,813	977,946	1002,395	217,304	-17,219	7,751	76,309
	10,000	11,305	44,877	881,043	903,069	217,380	-17,120	7,233	256,455
	9,000	12,305	39,547	776,401	795,812	217,367	-17,030	6,657	240,688
	8,000	13,305	34,470	676,728	693,646	217,376	-16,929	6,090	226,280
	7,000	14,305	29,646	582,025	596,576	217,416	-16,812	5,535	212,815
	6,000	15,305	25,078	492,347	504,656	217,504	-16,671	4,994	200,037
	5,000	16,305	20,774	407,841	418,037	217,669	-16,494	4,474	187,267
	4,000	17,305	16,747	328,781	337,000	217,965	-16,260	3,985	174,002
	3,000	18,305	13,027	255,740	262,134	218,491	-15,932	3,550	159,127
	2,000	19,305	8,494	166,764	170,933	218,762	-15,694	3,064	491,385
	1,000	20,305	3,843	75,445	77,331	218,796	-15,511	2,522	417,866
	0,288	21,017	1,000	19,632	20,123	218,848	-15,336	2,146	340,029
	0,000	21,305	0,000	0,000	0,000	218,870	-15,253	2,000	0,000

Tank Calibrations - doble casco 7 estrib

Fluid Type = Water Ballast Specific gravity = 1,025

Permeability = 100 %

Trim = 0 m (+ve by stern); Heel = 0 deg to starboard

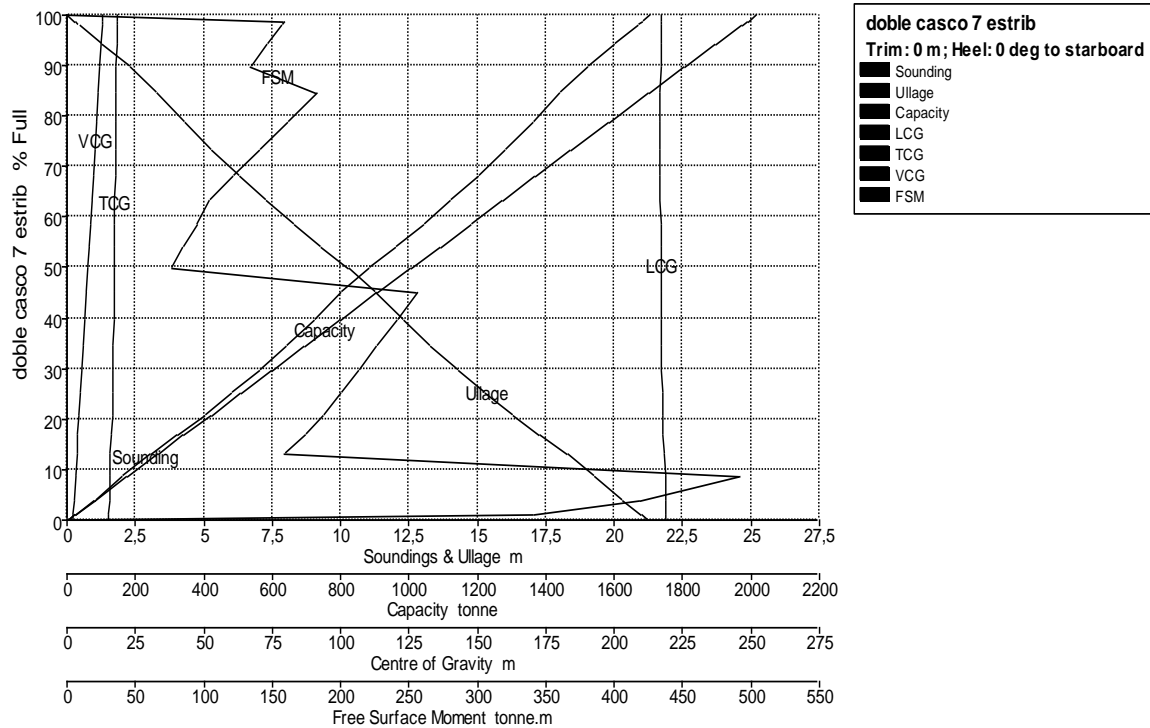

Tank Name	Sounding m	Ullage m	% Full	Capacity m ³	Capacity tonne	LCG m	TCG m	VCG m	FSM tonne.m
doble casco 7 estrib	21,305	0,000	100,000	1963,230	2012,311	217,225	18,246	13,010	0,000
	21,000	0,305	98,715	1937,998	1986,448	217,204	18,221	12,878	158,888
	20,849	0,456	98,000	1923,965	1972,065	217,187	18,208	12,805	156,971
	20,828	0,477	97,900	1922,002	1970,052	217,184	18,206	12,795	156,695
	20,000	1,305	94,064	1846,689	1892,857	217,088	18,135	12,402	146,291
	19,000	2,305	89,612	1759,289	1803,271	216,967	18,049	11,950	133,855
	18,000	3,305	84,392	1656,802	1698,222	216,900	17,957	11,424	182,175
	17,000	4,305	78,610	1543,288	1581,870	216,886	17,858	10,829	161,106
	16,000	5,305	73,120	1435,510	1471,398	216,881	17,757	10,253	140,353
	15,000	6,305	67,951	1334,037	1367,388	216,887	17,655	9,701	120,779
	14,000	7,305	63,117	1239,137	1270,115	216,911	17,552	9,180	104,098
	13,000	8,305	58,535	1149,178	1177,907	216,972	17,448	8,685	95,134
	12,000	9,305	54,036	1060,845	1087,366	217,116	17,336	8,201	84,796
	11,000	10,305	49,813	977,946	1002,395	217,304	17,219	7,751	76,309
	10,000	11,305	44,877	881,043	903,069	217,380	17,120	7,233	256,455

	9,000	12,305	39,547	776,401	795,812	217,367	17,030	6,657	240,688
	8,000	13,305	34,470	676,728	693,646	217,376	16,929	6,090	226,280
	7,000	14,305	29,646	582,025	596,576	217,416	16,812	5,535	212,815
	6,000	15,305	25,078	492,347	504,656	217,504	16,671	4,994	200,037
	5,000	16,305	20,774	407,841	418,037	217,669	16,494	4,474	187,267
	4,000	17,305	16,747	328,781	337,000	217,965	16,260	3,985	174,002
	3,000	18,305	13,027	255,740	262,134	218,491	15,932	3,550	159,127
	2,000	19,305	8,494	166,764	170,933	218,762	15,694	3,064	491,385
	1,000	20,305	3,843	75,445	77,331	218,796	15,511	2,522	417,866
	0,288	21,017	1,000	19,632	20,123	218,848	15,336	2,146	340,029
	0,000	21,305	0,000	0,000	0,000	218,870	15,253	2,000	0,000

Tank Calibrations - doble casco 8 bab

Fluid Type = Water Ballast Specific gravity = 1,025

Permeability = 100 %

Trim = 0 m (+ve by stern); Heel = 0 deg to starboard

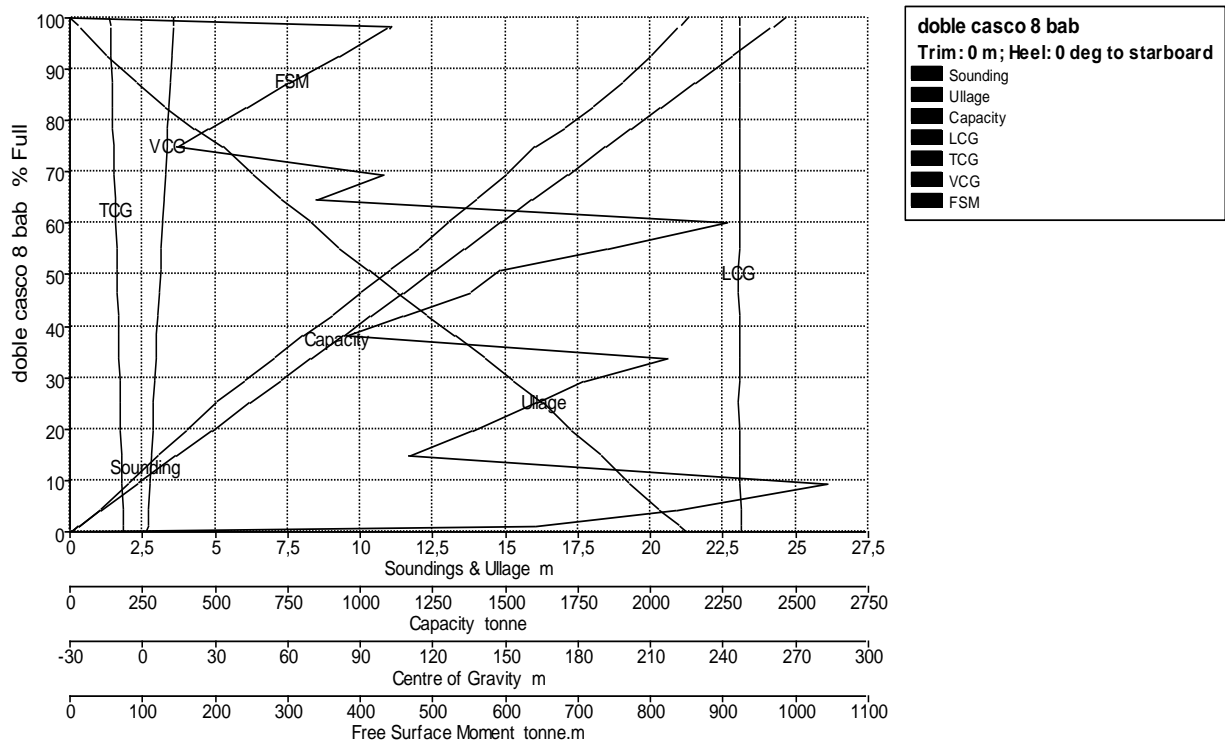

Tank Name	Sounding m	Ullage m	% Full	Capacity m ³	Capacity tonne	LCG m	TCG m	VCG m	FSM tonne.m
doble casco 8 bab	21,305	0,000	100,000	2402,817	2462,888	246,721	-13,475	12,736	0,000
	21,000	0,305	98,299	2361,936	2420,984	246,719	-13,384	12,556	442,306
	20,950	0,355	98,000	2354,761	2413,630	246,718	-13,369	12,525	438,372
	20,934	0,371	97,900	2352,358	2411,167	246,717	-13,364	12,514	437,059
	20,000	1,305	92,497	2222,536	2278,099	246,695	-13,073	11,932	368,674
	19,000	2,305	87,202	2095,315	2147,698	246,678	-12,766	11,351	301,057
	18,000	3,305	82,459	1981,346	2030,880	246,668	-12,470	10,824	242,729
	17,000	4,305	78,311	1881,660	1928,701	246,669	-12,195	10,364	191,079
	16,000	5,305	74,802	1797,363	1842,297	246,683	-11,950	9,981	147,231
	15,000	6,305	69,452	1668,806	1710,526	246,700	-11,637	9,403	431,858
	14,000	7,305	64,565	1551,374	1590,158	246,733	-11,333	8,865	339,119
	13,000	8,305	60,052	1442,949	1479,023	246,739	-11,063	8,368	905,437
	12,000	9,305	55,105	1324,080	1357,182	246,601	-10,834	7,816	738,427
	11,000	10,305	50,925	1223,643	1254,234	246,458	-10,639	7,348	592,347
	10,000	11,305	46,445	1115,996	1143,896	246,460	-10,411	6,855	551,740
	9,000	12,305	41,963	1008,286	1033,493	246,593	-10,148	6,357	458,272
	8,000	13,305	38,101	915,506	938,394	246,759	-9,894	5,936	379,440
	7,000	14,305	33,515	805,302	825,435	246,681	-9,721	5,448	822,688
	6,000	15,305	29,312	704,304	721,912	246,537	-9,564	5,009	706,567
	5,000	16,305	24,943	599,326	614,309	246,437	-9,391	4,579	641,596
	4,000	17,305	19,656	472,309	484,117	246,627	-9,127	4,061	553,090
	3,000	18,305	14,773	354,970	363,844	246,932	-8,774	3,583	466,393
	2,000	19,305	9,397	225,793	231,438	247,132	-8,469	3,071	1044,863
	1,000	20,305	4,197	100,837	103,358	247,259	-8,183	2,523	833,314
	0,266	21,039	1,000	24,028	24,629	247,436	-7,915	2,135	640,693
	0,000	21,305	0,000	0,000	0,000	247,532	-7,802	2,000	0,000

Tank Calibrations - doble casco 8 estrib

Fluid Type = Water Ballast Specific gravity = 1,025

Permeability = 100 %

Trim = 0 m (+ve by stern); Heel = 0 deg to starboard

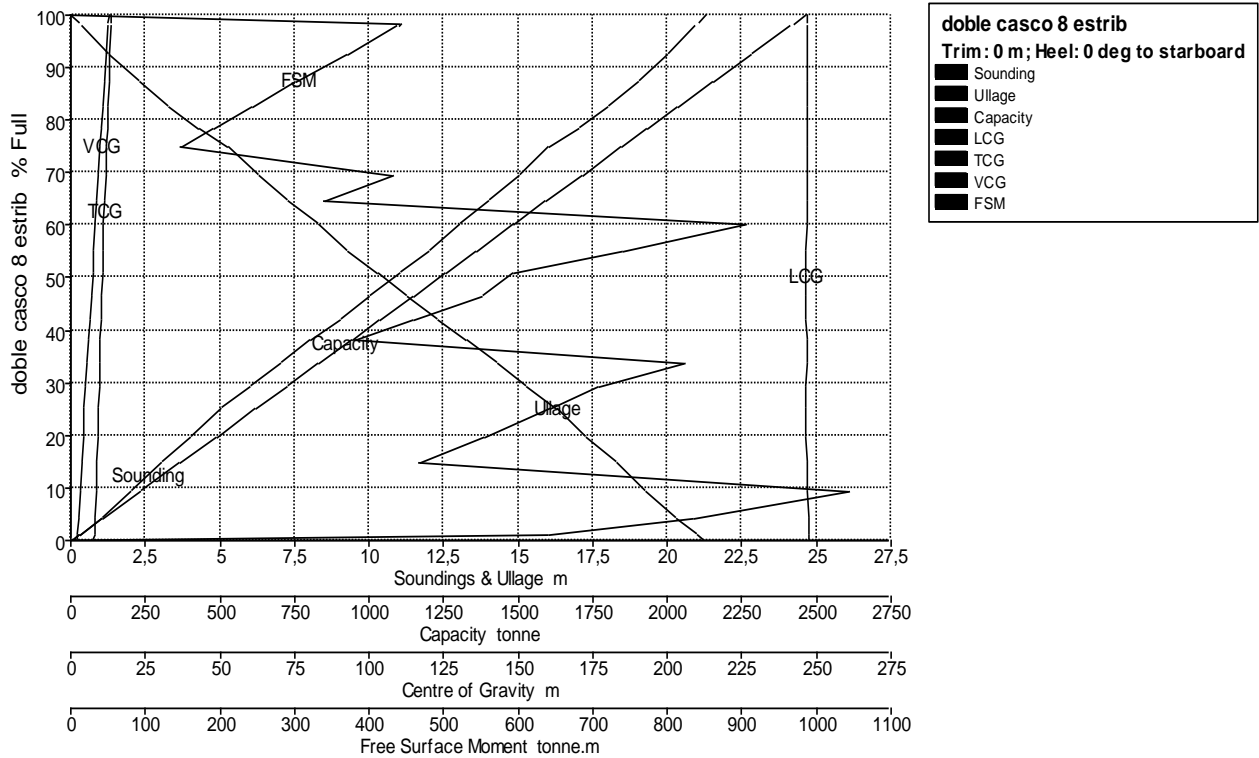

Tank Name	Sounding m	Ullage m	% Full	Capacity m ³	Capacity tonne	LCG m	TCG m	VCG m	FSM tonne.m
doble casco 8 estrib	21,305	0,000	100,000	2402,817	2462,888	246,721	13,475	12,736	0,000
	21,000	0,305	98,299	2361,936	2420,984	246,719	13,384	12,556	442,306
	20,950	0,355	98,000	2354,761	2413,630	246,718	13,369	12,525	438,372
	20,934	0,371	97,900	2352,358	2411,167	246,717	13,364	12,514	437,059
	20,000	1,305	92,497	2222,536	2278,099	246,695	13,073	11,932	368,674
	19,000	2,305	87,202	2095,315	2147,698	246,678	12,766	11,351	301,057
	18,000	3,305	82,459	1981,346	2030,880	246,668	12,470	10,824	242,729
	17,000	4,305	78,311	1881,660	1928,701	246,669	12,195	10,364	191,079
	16,000	5,305	74,802	1797,363	1842,297	246,683	11,950	9,981	147,231
	15,000	6,305	69,452	1668,806	1710,526	246,700	11,637	9,403	431,858
	14,000	7,305	64,565	1551,374	1590,158	246,733	11,333	8,865	339,119
	13,000	8,305	60,052	1442,949	1479,023	246,739	11,063	8,368	905,437
	12,000	9,305	55,105	1324,080	1357,182	246,601	10,834	7,816	738,427
	11,000	10,305	50,925	1223,643	1254,234	246,458	10,639	7,348	592,347
	10,000	11,305	46,445	1115,996	1143,896	246,460	10,411	6,855	551,740

	9,000	12,305	41,963	1008,286	1033,493	246,593	10,148	6,357	458,272
	8,000	13,305	38,101	915,506	938,394	246,759	9,894	5,936	379,440
	7,000	14,305	33,515	805,302	825,435	246,681	9,721	5,448	822,688
	6,000	15,305	29,312	704,304	721,912	246,537	9,564	5,009	706,567
	5,000	16,305	24,943	599,326	614,309	246,437	9,391	4,579	641,596
	4,000	17,305	19,656	472,309	484,117	246,627	9,127	4,061	553,090
	3,000	18,305	14,773	354,970	363,844	246,932	8,774	3,583	466,393
	2,000	19,305	9,397	225,793	231,438	247,132	8,469	3,071	1044,863
	1,000	20,305	4,197	100,837	103,358	247,259	8,183	2,523	833,314
	0,266	21,039	1,000	24,028	24,629	247,436	7,915	2,135	640,693
	0,000	21,305	0,000	0,000	0,000	247,532	7,802	2,000	0,000

Tank Calibrations - doble casco 9 bab

Fluid Type = Water Ballast Specific gravity = 1,025

Permeability = 100 %

Trim = 0 m (+ve by stern); Heel = 0 deg to starboard

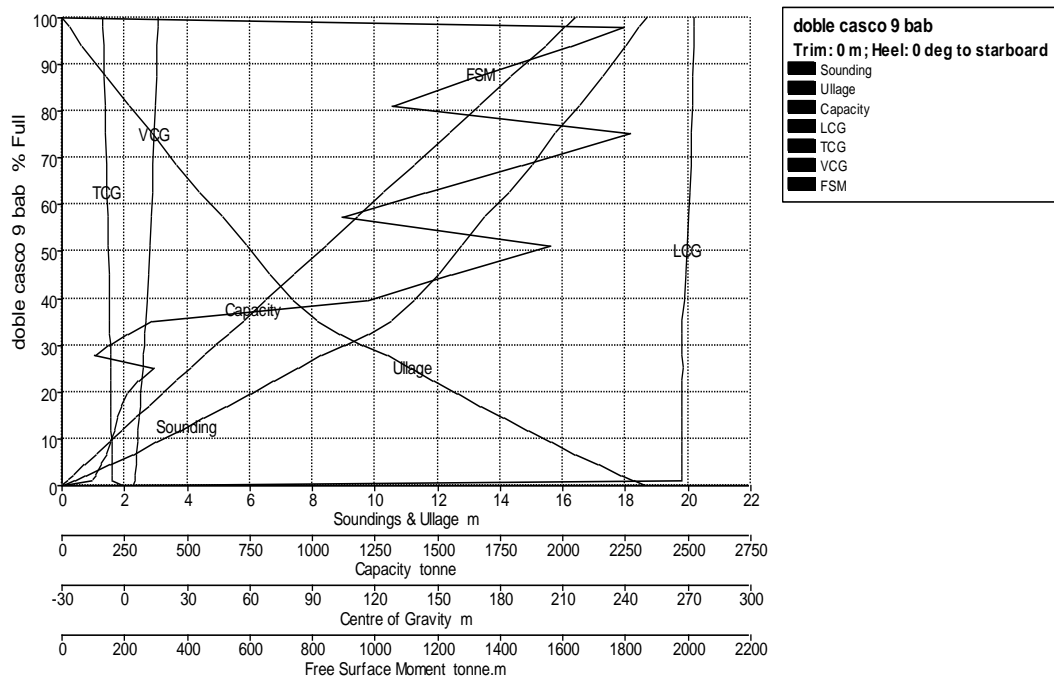

Tank Name	Sounding m	Ullage m	% Full	Capacity m ³	Capacity tonne	LCG m	TCG m	VCG m	FSM tonne.m
doble casco 9 bab	18,655	0,000	100,000	2000,115	2050,118	272,822	-10,370	16,127	0,000
	18,404	0,251	98,000	1960,113	2009,116	272,752	-10,258	15,983	1797,213
	18,394	0,261	97,900	1958,113	2007,065	272,749	-10,253	15,976	1792,840
	18,000	0,655	93,978	1879,673	1926,665	272,600	-10,050	15,689	1621,339
	17,250	1,405	87,117	1742,442	1786,003	272,307	-9,673	15,170	1318,047
	16,500	2,155	81,068	1621,461	1661,998	272,005	-9,321	14,695	1054,977
	15,750	2,905	75,359	1507,267	1544,949	271,680	-8,993	14,236	1815,318
	15,000	3,655	68,498	1370,038	1404,289	271,247	-8,650	13,655	1464,780
	14,250	4,405	62,536	1250,794	1282,064	270,790	-8,335	13,119	1159,021
	13,500	5,155	57,480	1149,670	1178,412	270,320	-8,060	12,642	893,971
	12,750	5,905	51,335	1026,763	1052,432	269,699	-7,809	12,032	1561,593
	12,000	6,655	45,075	901,546	924,085	268,918	-7,577	11,337	1240,845
	11,250	7,405	39,661	793,267	813,099	268,032	-7,379	10,661	974,134
	10,500	8,155	35,215	704,340	721,949	267,184	-7,211	10,045	285,875
	9,750	8,905	32,369	647,409	663,594	267,203	-7,014	9,628	205,601
	9,000	9,655	29,876	597,563	612,502	267,228	-6,839	9,260	145,945
	8,250	10,405	27,709	554,205	568,060	267,258	-6,684	8,946	102,886
	7,500	11,155	25,105	502,130	514,683	267,268	-6,588	8,578	294,598
	6,750	11,905	22,251	445,036	456,162	267,257	-6,535	8,167	241,218
	6,000	12,655	19,562	391,258	401,039	267,236	-6,497	7,774	206,489
	5,250	13,405	16,972	339,463	347,950	267,204	-6,466	7,392	191,527
	4,500	14,155	14,320	286,420	293,581	267,208	-6,427	6,997	178,674
	3,750	14,905	11,720	234,415	240,276	267,209	-6,384	6,603	168,635
	3,000	15,655	9,174	183,498	188,085	267,207	-6,333	6,207	157,702
	2,250	16,405	6,700	133,999	137,349	267,204	-6,272	5,812	143,824
	1,500	17,155	4,324	86,483	88,645	267,201	-6,200	5,419	126,510
	0,750	17,905	2,079	41,586	42,626	267,198	-6,117	5,030	106,236
	0,369	18,286	1,000	20,001	20,501	267,200	-6,071	4,836	94,874
	0,000	18,655	0,000	0,000	0,000	0,000	0,000	4,650	0,000

Tank Calibrations - doble casco 9 estrib

Fluid Type = Water Ballast Specific gravity = 1,025

Permeability = 100 %

Trim = 0 m (+ve by stern); Heel = 0 deg to starboard

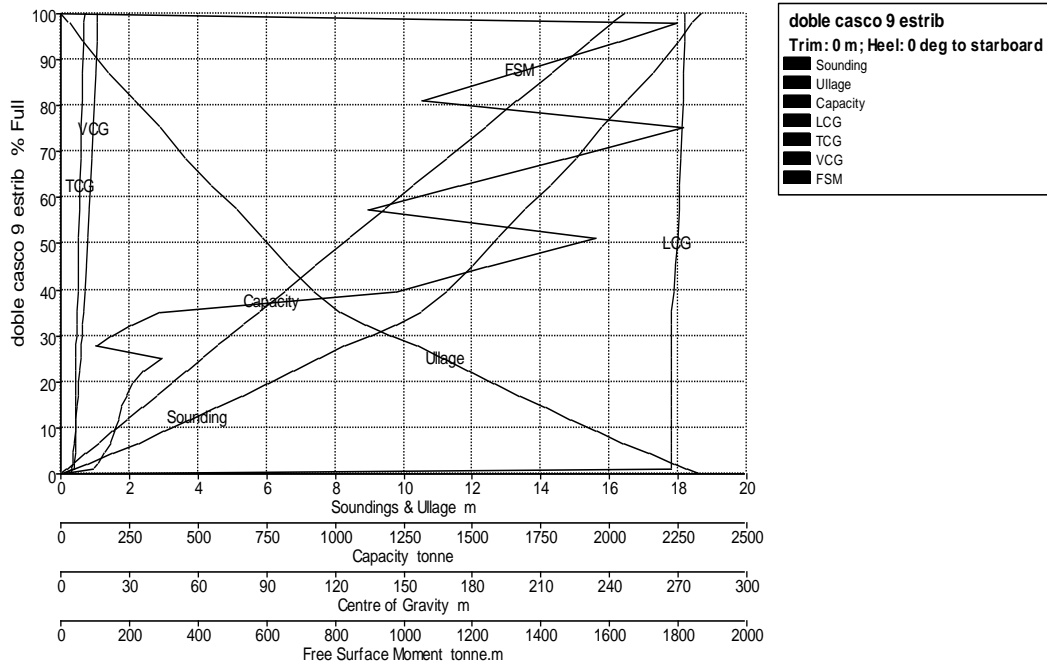

Tank Name	Sounding m	Ullage m	% Full	Capacity m ³	Capacity tonne	LCG m	TCG m	VCG m	FSM tonne.m
doble casco 9 estrib	18,655	0,000	100,000	2000,639	2050,655	272,819	10,372	16,129	0,000
	18,407	0,248	98,000	1960,626	2009,642	272,753	10,260	15,985	1798,334
	18,397	0,258	97,900	1958,625	2007,591	272,749	10,255	15,978	1793,961
	18,000	0,655	93,954	1879,673	1926,665	272,600	10,050	15,689	1621,339
	17,250	1,405	87,094	1742,442	1786,003	272,307	9,673	15,170	1318,047
	16,500	2,155	81,047	1621,461	1661,998	272,005	9,321	14,695	1054,977
	15,750	2,905	75,339	1507,267	1544,949	271,680	8,993	14,236	1815,318
	15,000	3,655	68,480	1370,038	1404,289	271,247	8,650	13,655	1464,780
	14,250	4,405	62,520	1250,794	1282,064	270,790	8,335	13,119	1159,021
	13,500	5,155	57,465	1149,670	1178,412	270,320	8,060	12,642	893,971
	12,750	5,905	51,322	1026,763	1052,432	269,699	7,809	12,032	1561,593
	12,000	6,655	45,063	901,546	924,085	268,918	7,577	11,337	1240,845
	11,250	7,405	39,651	793,267	813,099	268,032	7,379	10,661	974,134
	10,500	8,155	35,206	704,340	721,949	267,184	7,211	10,045	285,875
	9,750	8,905	32,360	647,409	663,594	267,203	7,014	9,628	205,601
	9,000	9,655	29,869	597,563	612,502	267,228	6,839	9,260	145,945

	8,250	10,405	27,701	554,205	568,060	267,258	6,684	8,946	102,886
	7,500	11,155	25,098	502,130	514,683	267,268	6,588	8,578	294,598
	6,750	11,905	22,245	445,036	456,162	267,257	6,535	8,167	241,218
	6,000	12,655	19,557	391,258	401,039	267,236	6,497	7,774	206,489
	5,250	13,405	16,968	339,463	347,950	267,204	6,466	7,392	191,527
	4,500	14,155	14,316	286,420	293,581	267,208	6,427	6,997	178,674
	3,750	14,905	11,717	234,415	240,276	267,209	6,384	6,603	168,635
	3,000	15,655	9,172	183,498	188,085	267,207	6,333	6,207	157,702
	2,250	16,405	6,698	133,999	137,349	267,204	6,272	5,812	143,824
	1,500	17,155	4,323	86,483	88,645	267,201	6,200	5,419	126,510
	0,750	17,905	2,079	41,586	42,626	267,198	6,117	5,030	106,236
	0,369	18,286	1,000	20,006	20,506	267,200	6,071	4,836	94,877
	0,000	18,655	0,000	0,000	0,000	0,000	0,000	4,650	0,000

Tank Calibrations - doble casco 10 bab

Fluid Type = Water Ballast Specific gravity = 1,025

Permeability = 100 %

Trim = 0 m (+ve by stern); Heel = 0 deg to starboard

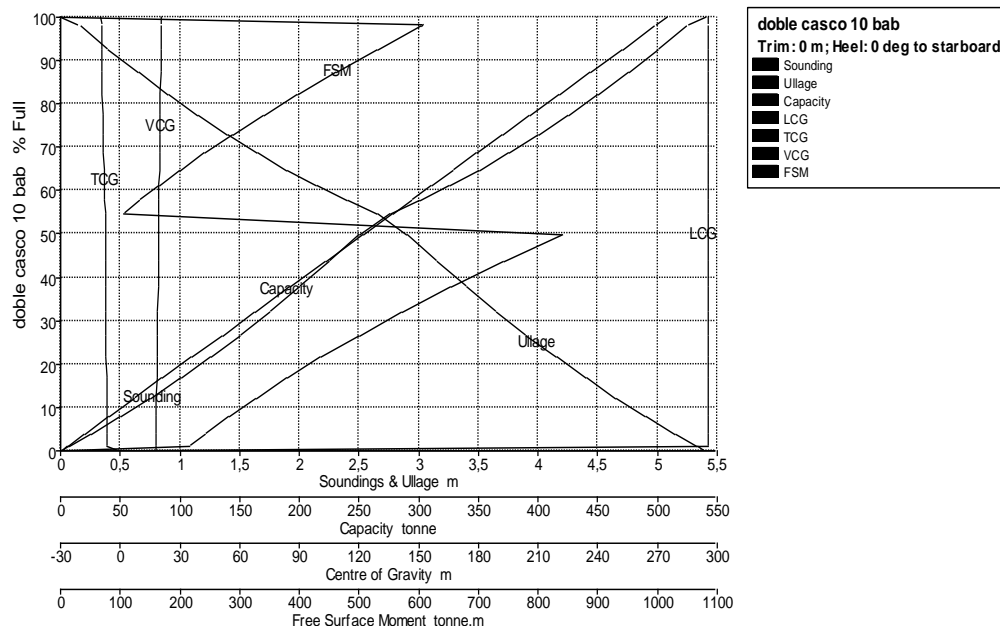

Tank Name	Sounding m	Ullage m	% Full	Capacity m ³	Capacity tonne	LCG m	TCG m	VCG m	FSM tonne.m
doble casco 10 bab	5,405	0,000	100,000	495,097	507,474	295,446	-9,628	20,601	0,000

	5,250	0,155	98,216	486,264	498,421	295,457	-9,551	20,554	606,696
	5,241	0,164	98,000	485,195	497,325	295,457	-9,544	20,548	603,740
	5,236	0,169	97,900	484,700	496,817	295,456	-9,540	20,545	602,367
	5,000	0,405	92,569	458,304	469,762	295,453	-9,360	20,403	529,585
	4,750	0,655	87,207	431,760	442,554	295,451	-9,166	20,257	459,420
	4,500	0,905	82,132	406,632	416,798	295,453	-8,971	20,117	396,010
	4,250	1,155	77,344	382,927	392,500	295,458	-8,773	19,983	338,778
	4,000	1,405	72,847	360,664	369,681	295,468	-8,575	19,857	286,666
	3,750	1,655	68,647	339,867	348,363	295,483	-8,377	19,739	240,012
	3,500	1,905	64,743	320,538	328,552	295,503	-8,181	19,632	199,072
	3,250	2,155	61,135	302,676	310,243	295,531	-7,988	19,534	163,383
	3,000	2,405	57,823	286,281	293,438	295,566	-7,799	19,449	132,229
	2,750	2,655	54,810	271,360	278,144	295,609	-7,617	19,376	105,489
	2,500	2,905	49,812	246,619	252,785	295,618	-7,485	19,263	839,669
	2,250	3,155	43,588	215,804	221,199	295,601	-7,385	19,118	741,204
	2,000	3,405	37,653	186,418	191,079	295,583	-7,287	18,975	651,681
	1,750	3,655	32,001	158,437	162,398	295,564	-7,192	18,834	571,297
	1,500	3,905	26,629	131,839	135,135	295,545	-7,100	18,694	499,378
	1,250	4,155	21,531	106,601	109,266	295,525	-7,009	18,556	434,673
	1,000	4,405	16,704	82,700	84,768	295,503	-6,922	18,420	377,211
	0,750	4,655	12,142	60,115	61,618	295,481	-6,837	18,287	326,402
	0,500	4,905	7,841	38,818	39,789	295,458	-6,755	18,155	281,006
	0,250	5,155	3,795	18,790	19,260	295,433	-6,676	18,026	241,161
	0,067	5,338	1,000	4,951	5,075	295,415	-6,620	17,934	215,246
	0,000	5,405	0,000	0,000	0,000	0,000	0,000	17,900	0,000

Tank Calibrations - doble casco 10 estrib

Fluid Type = Water Ballast Specific gravity = 1,025

Permeability = 100 %

Trim = 0 m (+ve by stern); Heel = 0 deg to starboard

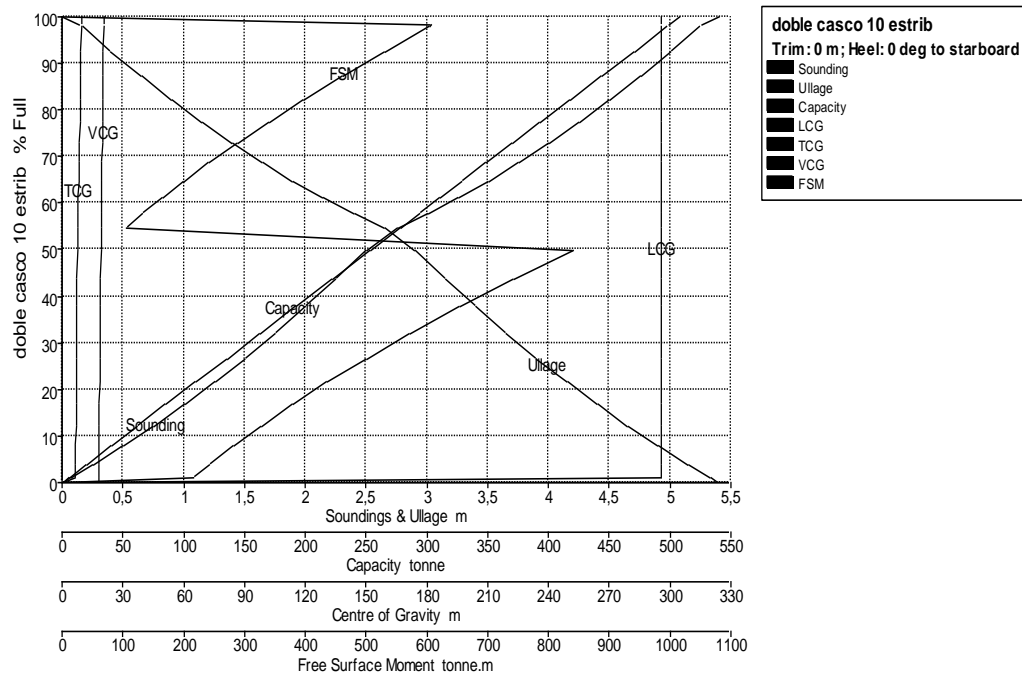

Tank Name	Sounding m	Ullage m	% Full	Capacity m ³	Capacity tonne	LCG m	TCG m	VCG m	FSM tonne.m
doble casco 10 estrib	5,405	0,000	100,000	495,097	507,474	295,446	9,628	20,601	0,000
	5,250	0,155	98,216	486,264	498,421	295,457	9,551	20,554	606,696
	5,241	0,164	98,000	485,195	497,325	295,457	9,544	20,548	603,740
	5,236	0,169	97,900	484,700	496,817	295,456	9,540	20,545	602,367
	5,000	0,405	92,569	458,304	469,762	295,453	9,360	20,403	529,585
	4,750	0,655	87,207	431,760	442,554	295,451	9,166	20,257	459,420
	4,500	0,905	82,132	406,632	416,798	295,453	8,971	20,117	396,010
	4,250	1,155	77,344	382,927	392,500	295,458	8,773	19,983	338,778
	4,000	1,405	72,847	360,664	369,681	295,468	8,575	19,857	286,666
	3,750	1,655	68,647	339,867	348,363	295,483	8,377	19,739	240,012
	3,500	1,905	64,743	320,538	328,552	295,503	8,181	19,632	199,072
	3,250	2,155	61,135	302,676	310,243	295,531	7,988	19,534	163,383
	3,000	2,405	57,823	286,281	293,438	295,566	7,799	19,449	132,229
	2,750	2,655	54,810	271,360	278,144	295,609	7,617	19,376	105,489
	2,500	2,905	49,812	246,619	252,785	295,618	7,485	19,263	839,669
	2,250	3,155	43,588	215,804	221,199	295,601	7,385	19,118	741,204

	2,000	3,405	37,653	186,418	191,079	295,583	7,287	18,975	651,681
	1,750	3,655	32,001	158,437	162,398	295,564	7,192	18,834	571,297
	1,500	3,905	26,629	131,839	135,135	295,545	7,100	18,694	499,378
	1,250	4,155	21,531	106,601	109,266	295,525	7,009	18,556	434,673
	1,000	4,405	16,704	82,700	84,768	295,503	6,922	18,420	377,211
	0,750	4,655	12,142	60,115	61,618	295,481	6,837	18,287	326,402
	0,500	4,905	7,841	38,818	39,789	295,458	6,755	18,155	281,006
	0,250	5,155	3,795	18,790	19,260	295,433	6,676	18,026	241,161
	0,067	5,338	1,000	4,951	5,075	295,415	6,620	17,934	215,246
	0,000	5,405	0,000	0,000	0,000	0,000	0,000	17,900	0,000

ANEXO III: CARACTERÍSTICAS TÉCNICAS MOTOR

Power, Speed and Lubricating Oil

MAN B&W K90ME9-TII

Power and Speed

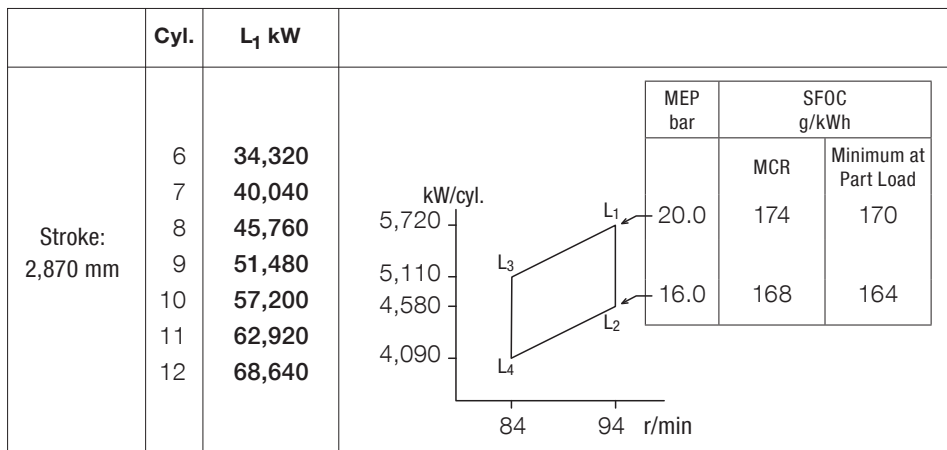

Fuel and lubricating oil consumption

At load Layout point	Specific fuel oil consumption g/kWh		Lubricating oil consumption	
	With high efficiency turbocharger		System oil Approximate g/kWh	MAN B&W Alpha cylinder lubricator
	100%	70%		
L ₁ and L ₂	174	170	0.1	0.65
L ₃ and L ₄	168	164		

Fig 1.03.01: Power, speed, fuel and lubrication oil

Engine Power Range and Fuel Oil Consumption

Engine Power

The following tables contain data regarding the power, speed and specific fuel oil consumption of the engine.

Engine power is specified in kW for each cylinder number and layout points L₁, L₂, L₃ and L₄:

Discrepancies between kW and metric horsepower (1 BHP = 75 kpm/s = 0.7355 kW) are a consequence of the rounding off of the BHP values.

L₁ designates nominal maximum continuous rating (nominal MCR), at 100% engine power and 100% engine speed.

L₂, L₃ and L₄ designate layout points at the other three corners of the layout area, chosen for easy reference.

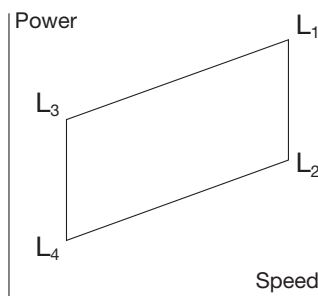

178 51 48-9.0

Fig. 1.04.01: Layout diagram for engine power and speed

Overload corresponds to 110% of the power at MCR, and may be permitted for a limited period of one hour every 12 hours.

The engine power figures given in the tables remain valid up to tropical conditions at sea level as stated in IACS M28 (1978), i.e.:

- Blower inlet temperature 45 °C
- Blower inlet pressure 1000 mbar
- Seawater temperature..... 32 °C
- Relative humidity60%

Specific Fuel Oil Consumption (SFOC)

The figures given in this folder represent the values obtained when the engine and turbocharger are matched with a view to obtaining the lowest possible SFOC values while also fulfilling the IMO NOX Tier II emission limitations.

Stricter emission limits can be met on request, using proven technologies.

The SFOC figures are given in g/kWh with a tolerance of 5% and are based on the use of fuel with a lower calorific value of 42,700 kJ/kg (~10,200 kcal/kg) at ISO conditions:

- Ambient air pressure 1,000 mbar
- Ambient air temperature 25 °C
- Cooling water temperature 25 °C

Although the engine will develop the power specified up to tropical ambient conditions, specific fuel oil consumption varies with ambient conditions and fuel oil lower calorific value. For calculation of these changes, see Chapter 2.

Lubricating oil data

The cylinder oil consumption figures stated in the tables are valid under normal conditions.

During running-in periods and under special conditions, feed rates of up to 1.5 times the stated values should be used.

ANEXO IV: PLANOS DISPOSICIÓN CONTENEDORES

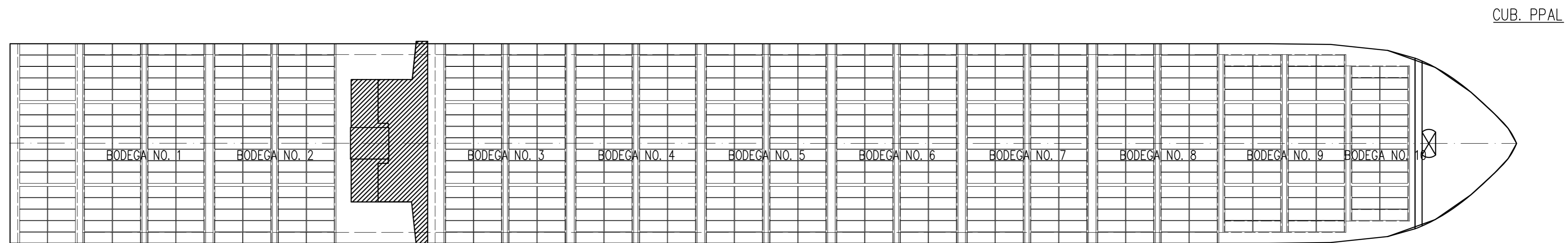
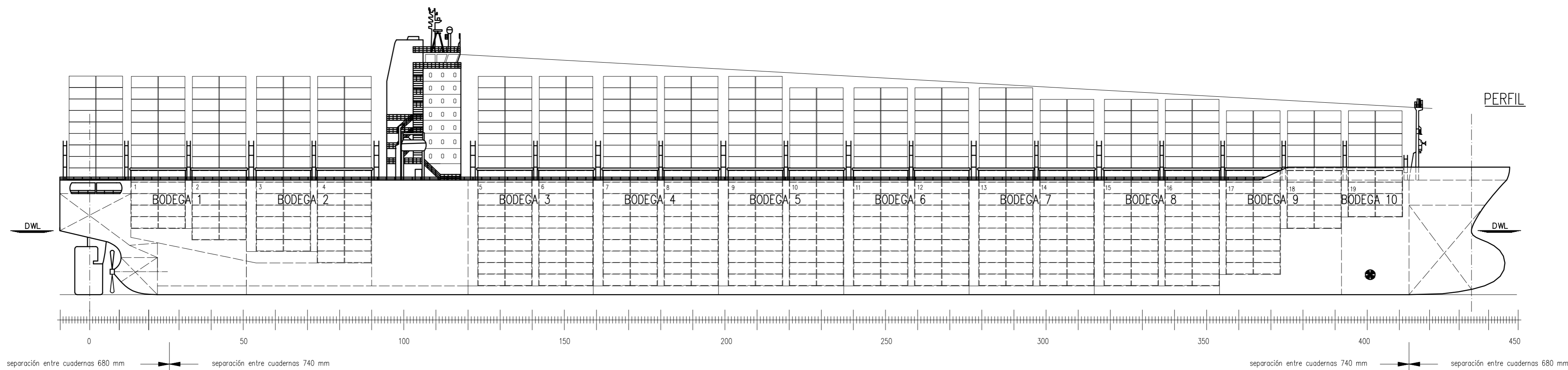

ESLORA TOTAL, LOA: 333.37 m
 ESLORA ENTRE PERPENDICULARES, LPP: 318.40 m
 MANGA, B: 44.23 m
 PUNTAL, D: 26.41 m
 CALADO, T: 14.73 m

Estado	Fecha	Nombre	Firmas	Proyecto:	A2
Dibujado	01/02/18	Nadia Conde		Portacontenedores 9000 TEU's	
Comprobado					
Escala:	Num proyecto: 18 - 02			Escuela Politécnica Superior de Ferrol	
1: 700	Alumna: Nadia Conde Alonso				
	Título: DISPOSICIÓN CONTENEDORES			Num plano: 8	Rev. 1/2
	Sustituido por:			Sustituye a:	

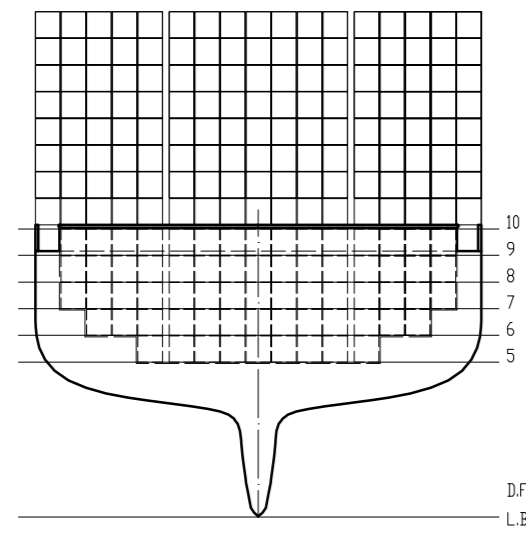

Cubierta 1 – Columna A/B
272 TEU's
Bodega 1 – Columna A/B
134 TEU's

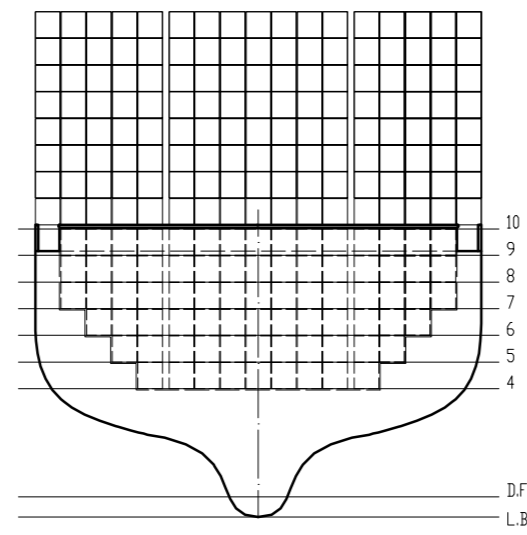

Cubierta 2 – Columna A/B
272 TEU's
Bodega 2 – Columna A/B
156 TEU's

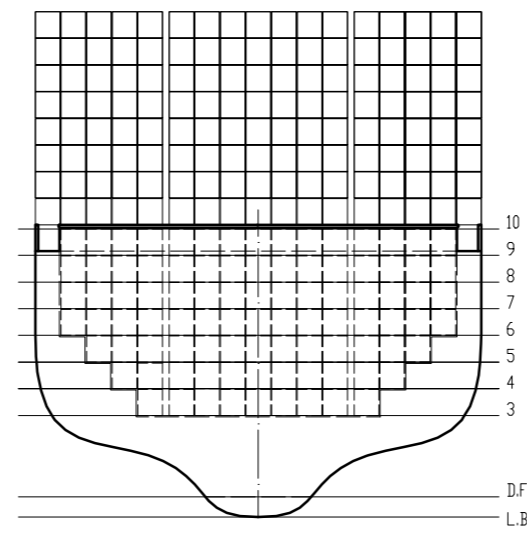

Cubierta 3 – Columna A/B
272 TEU's
Bodega 3 – Columna A/B
186 TEU's

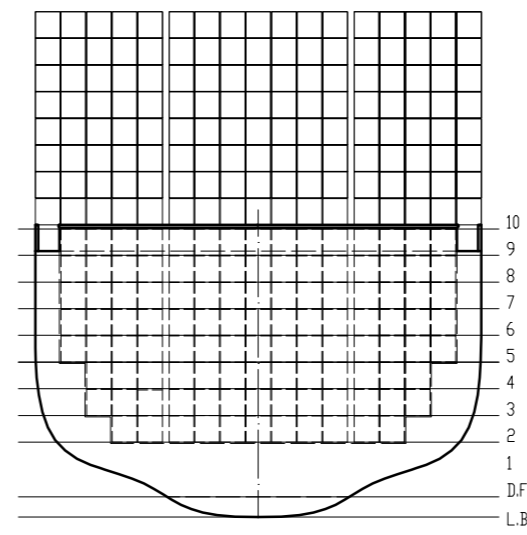

Cubierta 4 – Columna A
272 TEU's
Bodega 4 – Columna A/B
224 TEU's

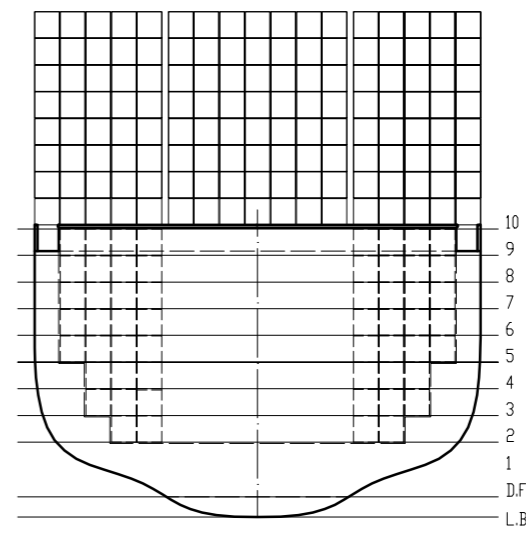

Cubierta 4 – Columna B
216 TEU's
Bodega 4 – Columna A/B
224 TEU's

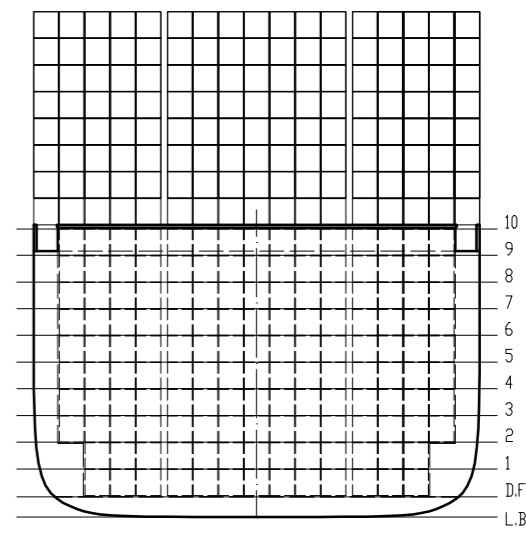

Cubierta 5 – Columna A/B
272 TEU's
Bodega 5 – Columna A/B
292 TEU's

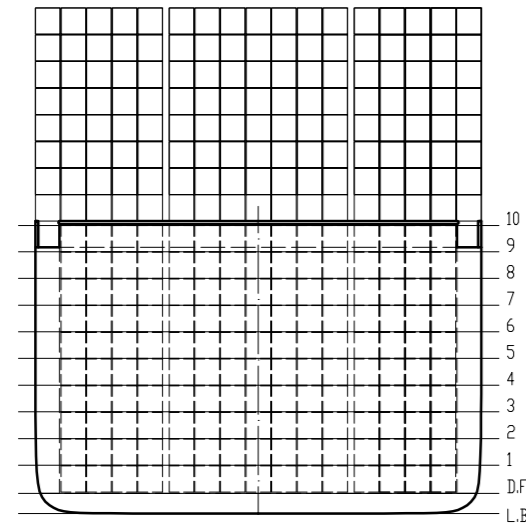

Cubierta 6 – Columna A/B
272 TEU's
Bodega 6 – Columna A/B
300 TEU's

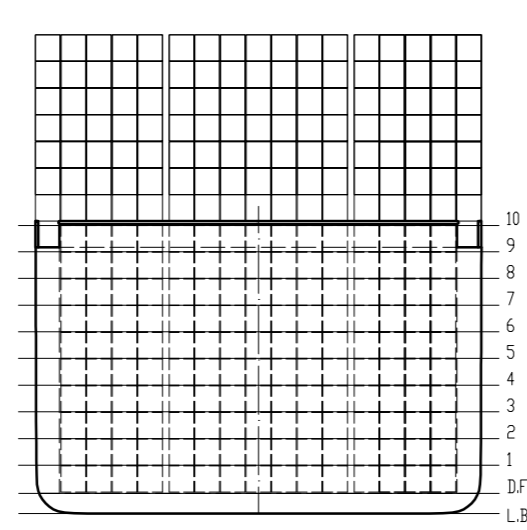

Cubierta 7 – Columna A/B
238 TEU's
Bodega 7 – Columna A/B
300 TEU's

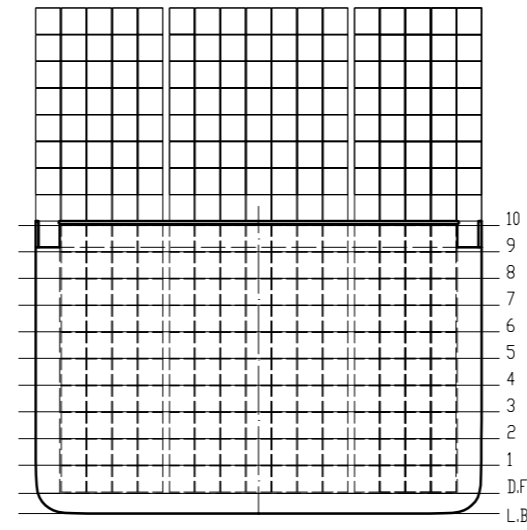

Cubierta 8 – Columna A/B
272 TEU's
Bodega 8 – Columna A/B
300 TEU's

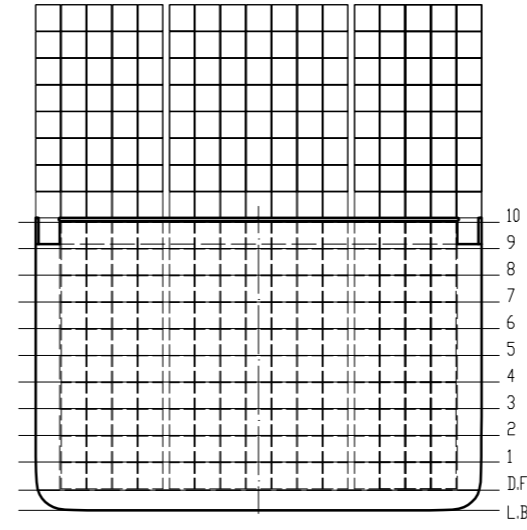

Cubierta 9 – Columna A/B
272 TEU's
Bodega 9 – Columna A/B
300 TEU's

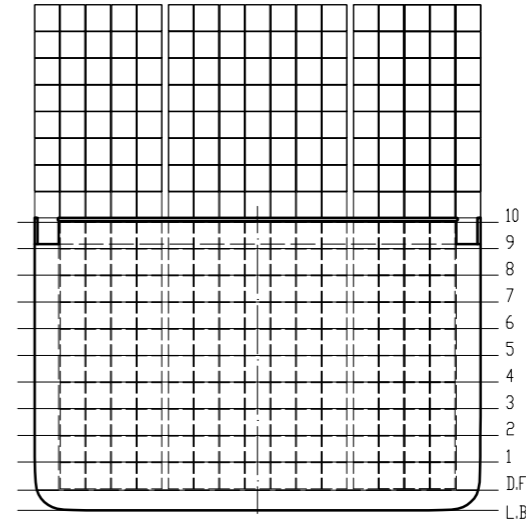

Cubierta 10 – Columna A/B
272 TEU's
Bodega 10 – Columna A/B
300 TEU's

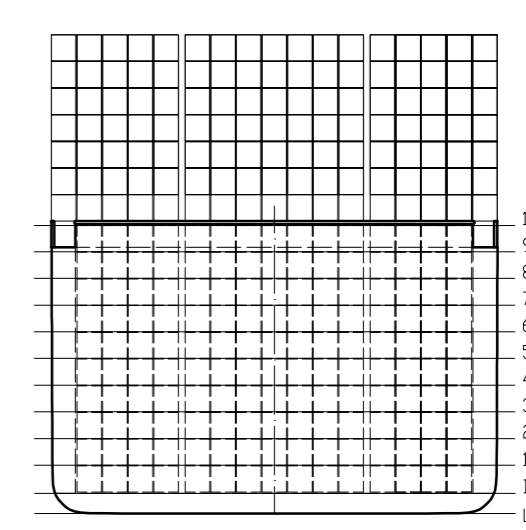

Cubierta 11 – Columna A/B
238 TEU's
Bodega 11 – Columna A/B
300 TEU's

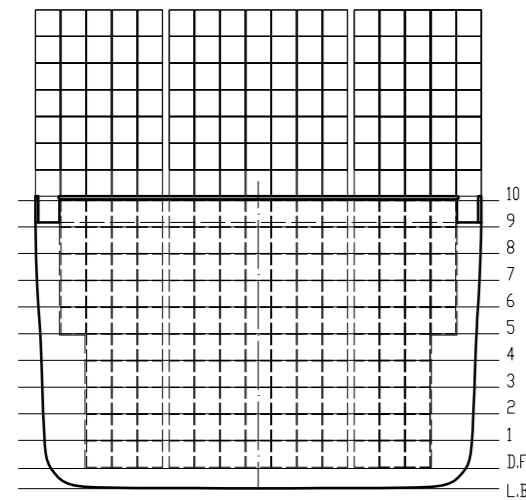

Cubierta 12 – Columna A/B
238 TEU's
Bodega 12 – Columna A/B
280 TEU's

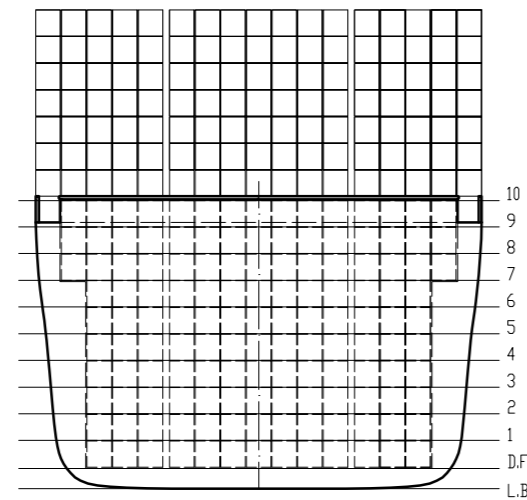

Cubierta 13 – Columna A/B
238 TEU's
Bodega 13 – Columna A/B
272 TEU's

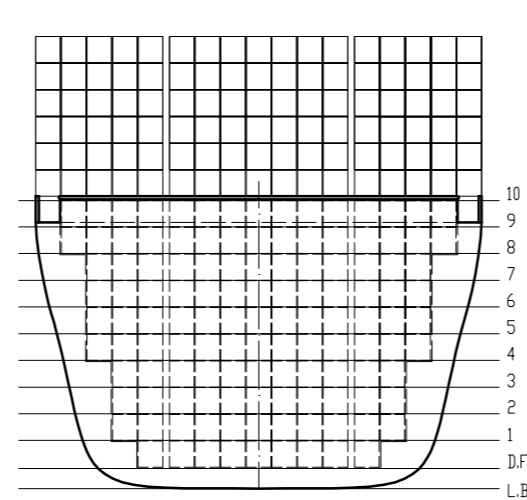

Cubierta 14 – Columna A/B
204 TEU's
Bodega 14 – Columna A/B
248 TEU's

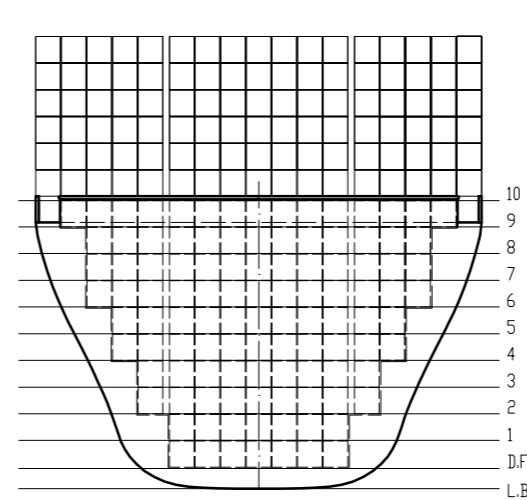

Cubierta 15 – Columna A/B
204 TEU's
Bodega 15 – Columna A/B
216 TEU's

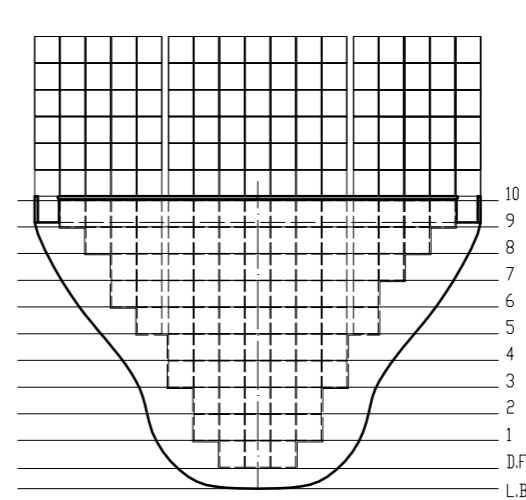

Cubierta 16 – Columna A/B
204 TEU's
Bodega 16 – Columna A/B
172 TEU's

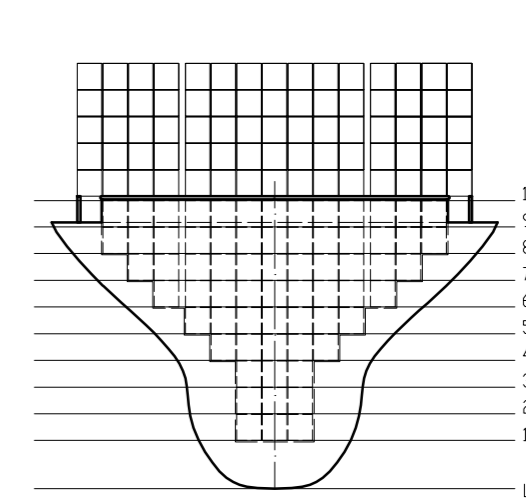

Cubierta 17 – Columna A/B
150 TEU's
Bodega 17 – Columna A/B
134 TEU's

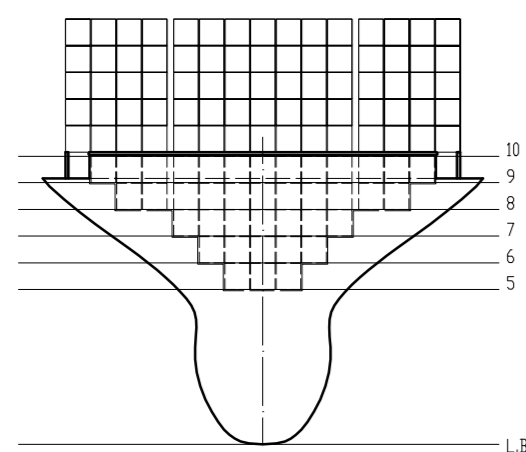

Cubierta 18 – Columna A/B
150 TEU's
Bodega 18 – Columna A/B
78 TEU's

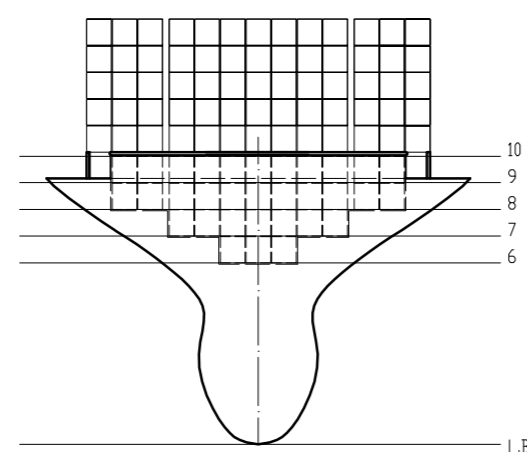

Cubierta 19 – Columna A
65 TEU's
Bodega 19 – Columna A/B
64 TEU's

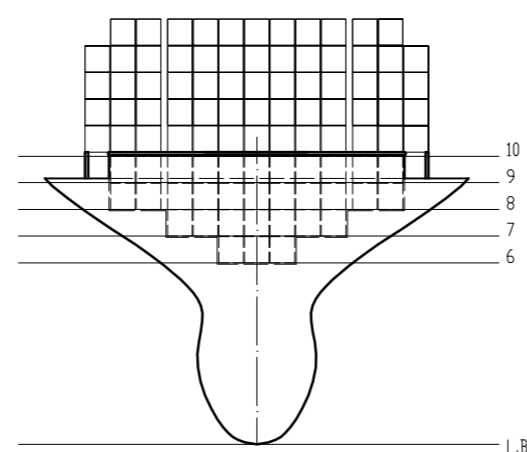

Cubierta 19 – Columna B
61 TEU's
Bodega 19 – Columna A/B
64 TEU's

TEU's en Cubierta 4744
TEU's en Bodegas 4256
TOTAL TEU's 9000

ESLORA TOTAL, LOA: 333.37 m
ESLORA ENTRE PERPENDICULARES, LPP: 318.40 m
MANGA, B: 44.23 m
PUNTA, D: 26.41 m
CALADO, T: 14.73 m

Estado	Fecha	Nombre	Firmas	Proyecto:	A2
Dibujado	02/02/18	Nadia Conde		Portacontenedores 9000 TEU's	
Comprobado					
Escala:	Num proyecto: 18 – 02			Escuela Politécnica Superior de Ferrol	
1: 750	Alumna: Nadia Conde Alonso				
	Título: DISPOSICIÓN CONTENEDORES			Num plano: 9	Rev. 2/2
	Sustituido por:			Sustituye a:	

ANEXO V: PLANO DISPOSICIÓN TANQUES

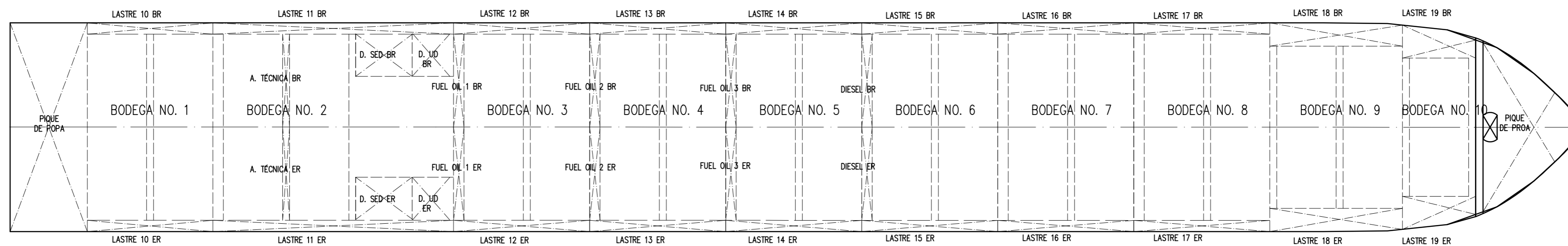
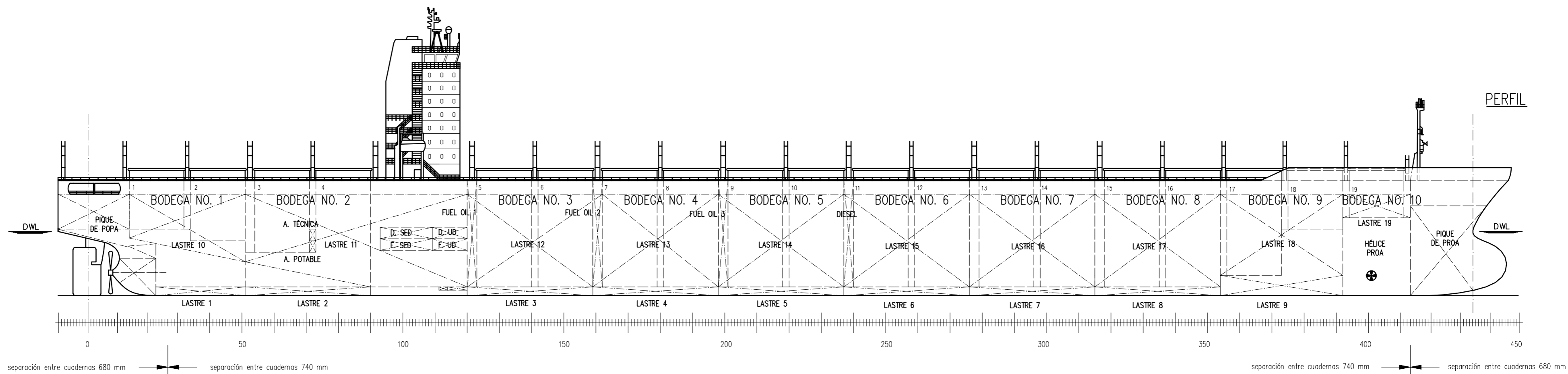

ESLORA TOTAL, LOA: 333.37 m
 ESLORA ENTRE PERPENDICULARES, LPP: 318.40 m
 MANGA, B: 44.23 m
 PUNTA, D: 26.41 m
 CALADO, T: 14.73 m

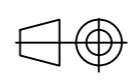
Estado	Fecha	Nombre	Firmas	Proyecto:	A2
Dibujado	02/02/18	Nadia Conde		Portacontenedores 9000 TEU's	
Comprobado					
Escala:	Num proyecto: 18 - 02			Escuela Politécnica Superior de Ferrol	
1:700	Alumna: Nadia Conde Alonso				
	Título: DISPOSICIÓN TANQUES			Num plano: 10	Rev. 1/2
	Sustituido por:			Sustituye a:	

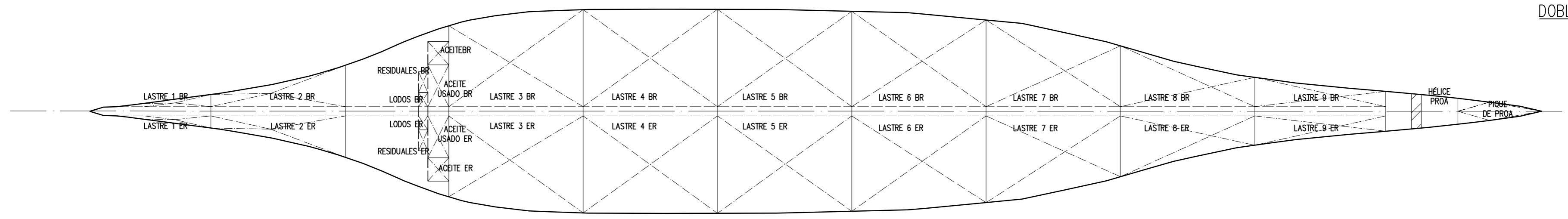
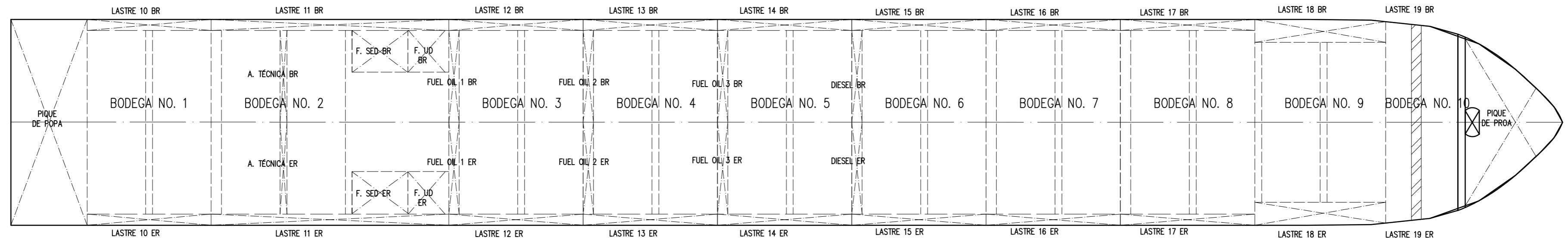

DOBLE FONDO

ESLORA TOTAL, LOA: 333.37 m
 ESLORA ENTRE PERPENDICULARES, LPP: 318.40 m
 MANGA, B: 44.23 m
 PUNTAL, D: 26.41 m
 CALADO, T: 14.73 m

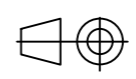
Estado	Fecha	Nombre	Firmas	Proyecto:	A2
Dibujado	02/02/18	Nadia Conde		Portacontenedores 9000 TEU's	
Comprobado					
Escala:	Num proyecto: 18 - 02			Escuela Politécnica Superior de Ferrol	
1:700	Alumna: Nadia Conde Alonso				
	Título: DISPOSICIÓN TANQUES			Num plano: 10	Rev.:
	Sustituido por:			Sustituye a:	
				Hoja: 2/2	