

TRABAJO FIN DE GRADO
15 105 P / BUQUE LNG DE MEMBRANA DE 145.000 m³

ALUMNO: ISMAEL GRANDAL MOURIZ

TUTOR: RAÚL VILLA CARO

CUADERNO 8

CUADERNA MAESTRA





DEPARTAMENTO DE INGENIERÍA NAVAL Y OCEÁNICA
TRABAJO FIN DE GRADO
CURSO 2014-2015

PROYECTO NÚMERO: 15 105 P

TIPO DE BUQUE: Buque tanque LNG de membrana

CLASIFICACIÓN, COTA Y REGLAMENTOS DE APLICACIÓN: DNV, SOLAS, MARPOL, CIG.

CARACTERÍSTICAS DE LA CARGA: gas natural licuado con capacidad para 145.000 m³.

VELOCIDAD Y AUTONOMÍA: 19,5 nudos a la velocidad de servicio, 85% MCR + 15% MM. 12.000 millas a la velocidad de servicio.

SISTEMAS Y EQUIPOS DE CARGA / DESCARGA: los habituales en este tipo de buque.

PROPULSIÓN: Propulsión Diesel eléctrico. Dos líneas de ejes

TRIPULACIÓN Y PASAJE: 35 tripulantes en camarotes individuales.

OTROS EQUIPOS E INSTALACIONES: Las habituales en este tipo de buque.

Ferrol, Abril de 2015

ALUMNO: D. Ismael Grandal Mouriz

ÍNDICE:

1. INTRODUCCIÓN.....	4
2. DETERMINACIÓN DE LAS DIMENSIONES DE ESCANTILLONADO.....	5
3. ESCANTILLONADO DE LOS ELEMENTOS ESTRUCTURALES DEL BUQUE.....	7
4. MOMENTOS FLECTORES, FUERZAS CORTANTES, MÓDULO E INERCIA.....	24
5. RESISTENCIA LONGITUDINAL.....	27
6. BIBLIOGRAFÍA.....	34
7. ANEXO I: PLANO CUADERNA MAESTRA.....	35
8. ANEXO II: REGLAMENTO DN.....	37
9. ANEXO III: REPORT RESISTENCIA LONGITUDINAL.....	48

1.INTRODUCCIÓN

El objetivo de este cuaderno es realizar el escantillonado de diversos elementos del buque para de esta forma poder obtener el módulo resistente del buque en la cuaderna maestra y comprobar que resiste estructuralmente los momentos flectores máximos generados en las condiciones de arrufo y quebranto. Para ello será necesario escantillonar todos los elementos que participan en la resistencia longitudinal del buque.

En esta fase del proyecto se realizaran los cálculos del escantillonado tratando a nuestro buque como un buque tanque. En las siguientes fases del proyecto deberemos aplicar la sección específica para buques LNG de la Sociedad de Clasificación. Elegiremos DNV (revisión 2001). Todas las fórmulas utilizadas están copiadas directamente del reglamento y se indica la parte, el capítulo y la sección.

Adjuntamos los datos obtenidos en cuadernos anteriores ya que serán necesarios para la elaboración de este cuaderno.

L	269,7
B	43,2
D	26,3
T	11,5
Volumen	145.000
Δ	105.379
V	19,5
Fn	0,1950
Cb	0,7673
Cm	0,9971
Cp	0,7905

Las condiciones de carga definidas en el cuaderno 5 son:

- a) Buque en la condición de **salida a plena carga**, distribuida esta de forma homogénea en todos los espacios de carga y con la totalidad de provisiones y combustible.
- b) Buque en la condición de **llegada en plena carga**, distribuida esta de forma homogénea en todos los espacios de carga y con el 10 % de provisiones y

combustibles.

c) Buque en condición de **salida, en lastre** sin carga, pero con la totalidad de provisiones y combustibles.

d) Buque en la condición de **llegada en lastre** sin carga, y con el 10% de provisiones y combustible

La cuaderna maestra que vamos a utilizar los detallamos a continuación:

Ahora vamos a ajustar la geometría de esta cuaderna maestra del buque base a nuestras condiciones de proyecto. Por tanto, vamos a tener las siguientes dimensiones y separaciones entre refuerzos:

- Separación horizontal entre longitudinales del doble fondo: 1 metro.
- Separación vertical entre longitudinales doble casco: 0.8 metros.
- Separación horizontal entre longitudinales cubierta principal: 1 metro.
- Separación horizontal entre longitudinales de los domos: 1 metros.

Los planos de diseño conceptual de la cuaderna maestra los adjuntamos como anexo. Las medidas no están escaladas con los cálculos del presente cuaderno, pero el diseño es análogo.

2. DETERMINACIÓN DE LAS DIMENSIONES DE ESCANTILLONADO

Según el DNV Pt. 3 Ch. 1 Secc.1:

B.101

Calado de escantillonado

El reglamento nos lo define como el calado medio en la línea de verano. Debemos hacer una estimación del francobordo del buque y el calado máximo obtenido es el que se utilizará para realizar el diseño de la estructura del buque. En nuestro caso, como estamos penalizados por estabilidad, utilizaremos el calado a la condición de carga más desfavorable.

Podemos observar que la condición más desfavorable es la salida de puerto a plena carga (1). Por tanto, nuestro calado de escantillonado será la suma de este calado a plena carga más un margen de error, que será de medio metro: $12,085 + 0,5 = 12,585$.

Tomaremos 12,6 m.

Eslora de escantillonado

Calcularemos la eslora de escantillonado siguiendo el siguiente criterio:

$$L = \max \left\{ \begin{array}{l} 0.96 \cdot L_{WL} \\ \min \left\{ \begin{array}{l} 0.97 \cdot L_{WL} \\ L_{PP} \end{array} \right. \end{array} \right.$$

$$L_{pp} = 270 \text{ m.}$$

$$L_{wl} = 274,52 \text{ m.}$$

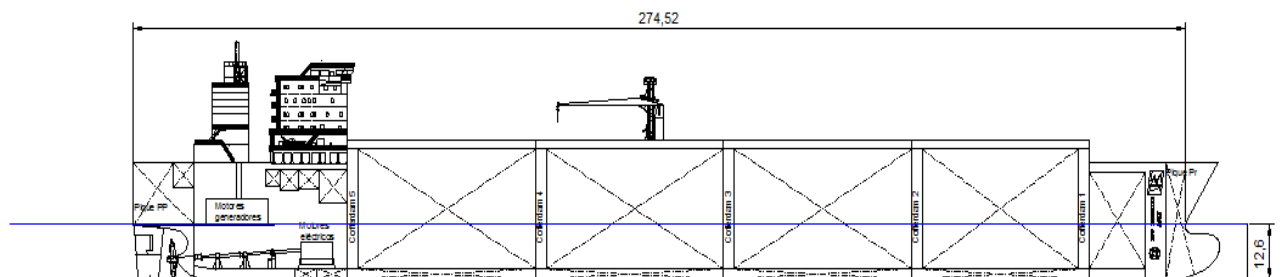

Por otro lado: $0.97 \cdot 274,52 = 266,28 \text{ m.}$

Por tanto, nuestra eslora de escantillonado será de 266.28 m.

$$L_{\text{escantillonado}} = 266.28 \text{ m.}$$

Manga de escantillonado

Se toma el valor de la manga máxima al calado de verano: 43.2 m

Puntal de escantillonado

Tomamos el valor de la distancia vertical desde la línea base a la cubierta continua más alta medida en el centro del buque. Coincide con el puntal de trazado: 26,3 m.

Coefficiente de bloque de escantillonado

Se obtiene con las dimensiones de escantillonado y el desplazamiento de escantillonado:

$$C_B = \frac{\Delta_s}{\rho L_s B_s T_s}$$

Donde:

Δ (escantillonado) = 108.490 t.

Tendremos, por tanto:

$$C_B = 0,7285$$

3-ESCANTILLONADO DE LOS ELEMENTOS ESTRUCTURALES DEL BUQUE

Materiales

Se utilizará acero de resistencia normal NV-NS con las siguientes características:

- Modulo de Young = $2.06 \cdot 10^5 \text{ N/mm}^2$
- $f_1=1$
- Tensión elástica mínima = 235 N/mm^2 .

Puntos de carga (load points)

Pt.3 Ch. 1 Sec. 4

A 200 Definitions:

201 Symbols:

p = design pressure in kN/m^2
 r = density of liquid or stowage rate of dry cargo in t/m^3 .

202 The load point for which the design pressure is to be calculated is defined for various strength members as follows:

- a) For plates:
 midpoint of horizontally stiffened plate field.
 Half of the stiffener spacing above the lower support of vertically stiffened plate field, or at lower edge of plate when the thickness is changed within the plate field.
- b) For stiffeners:
 midpoint of span.
 When the pressure is not varied linearly over the span the design pressure is to be taken as the greater of:

$$p_m \text{ and } \frac{p_a + p_b}{2}$$

p_m , p_a and p_b are calculated pressure at the midpoint and at each end respectively.

- c) For girders:
 midpoint of load area.

Cálculo de los parámetros principales

Pt. 3 Ch. 1 Sec. 4

B 200 Basic parameters

201 The acceleration, sea pressures and hull girder loads have been related to a wave coefficient as given in Table B1.

L	C_W
$L \leq 100$	$0,0792 L$
$100 < L < 300$	$10,75 - [(300-L)/100]^{3/2}$
$300 \leq L \leq 350$	$10,75$
$L > 350$	$10,75 - [(L-350)/150]^{3/2}$

En nuestro caso tenemos que $C_W = 10,55$.

203 A common acceleration parameter is given by:

$$a_0 = \frac{3C_W}{L} + C_V C_{V1}$$

$$C_V = \frac{\sqrt{L}}{50}, \text{ maximum } 0,2$$

$$C_{V1} = \frac{V}{\sqrt{L}}, \text{ minimum } 0,8$$

$$a_0 = \frac{3 \cdot 10,55}{266,28} + 0,2 \cdot 1,194 = 0,3576$$

$$C_V = \frac{\sqrt{266,28}}{50} = 0,326 \text{ Cogemos } C_V = 0,2$$

$$C_{V1} = \frac{19,5}{\sqrt{266,28}} = 1,194$$

B 600 Combined vertical acceleration

601 Normally the combined vertical acceleration (acceleration of gravity not included) may be approximated by:

$$a_v = \frac{k_v g_0 a_0}{C_B} \quad (\text{m/s}^2)$$

$k_v = 1,3$ aft of A.P.
 $= 0,7$ between $0,3 L$ and $0,6 L$ from A.P.
 $= 1,5$ forward of F.P.

$$a_v = \frac{0,7 \cdot 9,81 \cdot 0,3576}{0,7285} = 3,3708 \text{ m/s}^2$$

C 200 Sea pressures

201 The pressure acting on the ship's side, bottom and weather deck is to be taken as the sum of the static and the dynamic pressure as:

— for load point below summer load waterline :

$$p_1 = 10 h_0 + p_{dp}^{1)} \quad (\text{kN/m}^2)$$

— for load point above summer load waterline :

$$p_2 = a (p_{dp} - (4 + 0,2 k_s) h_0)^{1)} \quad (\text{kN/m}^2)$$

= minimum 6,25 + 0,025 L₁ for sides
= minimum 5 for weather decks.

The pressure p_{dp} is taken as:

$$p_{dp} = p_l + 135 \frac{y}{B + 75} - 1,2 (T - z) \quad (\text{kN/m}^2)$$

$$p_l = k_s C_W + k_f$$

$$= (k_s C_W + k_f) \left(0,8 + 0,15 \frac{V}{\sqrt{L}} \right) \quad \text{if } \frac{V}{\sqrt{L}} > 1,5$$

$$k_s = 3 C_B + \frac{2,5}{\sqrt{C_B}} \quad \text{at AP and aft}$$

= 2 between 0,2 L and 0,7 L from AP

$$= 3 C_B + \frac{4,0}{C_B} \quad \text{at FP and forward.}$$

Between specified areas k_s is to be varied linearly.

- a = 1,0 for ship's sides and for weather decks forward of 0,15L from FP, or forward of deckhouse front, whichever is the foremost position
- = 0,8 for weather decks elsewhere
- h_0 = vertical distance from the waterline at draught T to the load point (m)
- z = vertical distance from the baseline to the load point, maximum T (m)
- y = horizontal distance from the centre line to the load point, minimum B/4 (m)
- C_W = as given in B200
- k_f = the smallest of T and f
- f = vertical distance from the waterline to the top of the ship's side at transverse section considered, maximum 0,8 C_W (m)
- L₁ = ship length, need not be taken greater than 300 (m).

1) For ships with service restrictions, p_1 and the last term in p_1 may be reduced by the percentages given in B302. C_W should not be reduced.

$$C_w = 10,55$$

$$K_f = 8,424$$

$$f = 0,8 \cdot 10,55 = 8,424 \text{ m.}, \text{ menor que } 26,3 - 12,6 = 13,7 \text{ m.}$$

$$K_s = 2$$

$$p_1 = 2 \cdot 10,55 + 8,424 = 29,484 \text{ kN/m}^2$$

ESCANTILLONADO

A continuación se presenta el cálculo de escantillones y módulos mínimos requeridos por el DNV. Una vez obtenidos los diferentes parámetros se deberá comprobar la validez de la estructura mediante el cálculo del módulo resistente de la cuaderna maestra.

En los cálculos que se precisen valores calculados anteriormente, no se volverán a presentar de nuevo.

En los cálculos en los que se precisen valores calculados con anterioridad, no los volveremos a presentar.

Pt. 3 Ch. 1 Sec. 67

C200 Quilla plana

C 200 Keel plate

201 A keel plate is to extend over the complete length of the ship. The breadth is not to be less than:

$$b = 800 + 5 L \quad (\text{mm}).$$

202 The thickness is not to be less than:

$$t = 7,0 + \frac{0,05L_1}{\sqrt{f_1}} + t_k \quad (\text{mm})$$

The thickness is in no case to be less than that of the adjacent bottom plate.

$$b = 2.131,4 \text{ mm} \rightarrow 2.135 \text{ mm}.$$

$$t = 7,0 + \frac{0,05 \cdot 266,28}{\sqrt{1}} + 2,5 = 22,814 \text{ mm.} \rightarrow 23 \text{ mm}.$$

C300 Fondo y pantoque

302 The thickness requirement corresponding to lateral pressure is given by:

$$t = \frac{15,8k_s s \sqrt{p}}{\sqrt{\sigma}} + t_k \quad (\text{mm})$$

$p = p_1$ to p_3 (when relevant) in Table B1

$\sigma = 175 f_1 - 120 f_{2b}$, maximum $120 f_1$ when transverse frames, within $0,4L$

= $120 f_1$ when longitudinals, within $0,4 L$

= $160 f_1$ within $0,1 L$ from the perpendiculars.

Between specified regions the σ -value may be varied linearly.

f_{2b} = stress factor as given in A 200

Necesitamos el valor de k_a de A201

f_{2b} = stress factor below the neutral axis of the hull girder depending on surplus in midship section modulus and maximum value of the actual still water bending moments:

$$f_{2b} = \frac{5,7(M_S + M_W)}{Z_B}$$

k_a = correction factor for aspect ratio of plate field
 = $(1,1 - 0,25 s/l)^2$
 = maximum 1,0 for $s/l = 0,4$
 = minimum 0,72 for $s/l = 1,0$

Y de la Sec. 4 C201

The pressure p_{dp} is taken as:

$$p_{dp} = p_l + 135 \frac{Y}{B + 75} - 1,2 (T - z)$$

B201

Table B1 Design loads		
Structure	Load type	p (kN/m ²)
Outer bottom	Sea pressure	$p_1 = 10 T + p_{dp}$ (kN/m ²) ¹⁾
	Net pressure in way of cargo tank or deep tank	$p_2 = \rho(g_0 + 0,5 a_v) h_s - 10 T_M$ $p_3 = \rho g_0 h_s + p_0 - 10 T_M$
Inner bottom	Dry cargo in cargo holds	$p_4 = \rho(g_0 + 0,5 a_v) H_C$
	Ballast in cargo holds	$p_5 = (10 + 0,5 a_v) h_s$ $p_6 = 6,7(h_s + \phi b) - 1,2\sqrt{H\phi b_t}$ ²⁾ $p_7 = 0,67(10h_p + \Delta p_{dyn})$ $p_8 = 10h_s + p_0$
	Liquid cargo in tank above	$p_9 = \rho(g_0 + 0,5 a_v) h_s$ $p_{10} = \rho g_0 [0,67(h_s + \phi b) - 0,12\sqrt{H\phi b_t}]$ ²⁾ $p_{11} = 0,67(\rho g_0 h_p + \Delta p_{dyn})$ $p_{12} = \rho g_0 h_s + p_0$
Inner bottom, floors and girders	Pressure on tank boundaries in double bottom	$p_{13} = 0,67(10h_p + \Delta p_{dyn})$ $p_{14} = 10h_s + p_0$
	Minimum pressure	$p_{15} = 10 T$

1) For ships with service restrictions the last term in p_1 may be reduced by the percentages given in Sec. 4 B202.
 2) p_6 and p_{10} to be used in tanks/holds with largest breadth $> 0,4 B$.

Y de la C304

304 The thickness is not to be less than:

$$t = 5,0 + \frac{0,04L_1}{\sqrt{f_1}} + t_k \quad (\text{mm})$$

Algunos parámetros que consideramos son:

-y: la distancia horizontal en metros, desde la línea de crujía al punto de cálculo considerado.

-z: distancia vertical en metros, desde la línea base hasta el punto de cálculo considerado.

-hs: distancia vertical en metros, desde el punto de cálculo a la parte superior del tanque.

$$-T_m = 2 + 0,02 \cdot L = 2 + 0,02 \cdot 266,28 = 7,325 \text{ m (calado)}$$

$$-p_0 = 25 \text{ kN/m}^2$$

$$-p_1 = 29,484 \text{ kN/m}^2$$

Según la tabla B201 tenemos:

$$p_{dp} = 29,484 + 135 \cdot \frac{10,8}{43,2 + 75} - 1,2 \cdot (12,6 - 0) = 26,64 \text{ kN/m}^2$$

$$p_1 = 10 \cdot 12,5 + 26,64 = 151,64 \frac{\text{kN}}{\text{m}^2}$$

$$\begin{aligned} p_2 &= 1,025 \cdot (9,81 + 0,5 \cdot 3,3708) \cdot 26,3 - 10 \cdot (2 + 0,02 \cdot 266,28) \\ &= 236,63 \text{ kN/m}^2 \end{aligned}$$

$$p_3 = 1,025 \cdot 9,81 \cdot 26,3 + 25 - 10 \cdot (2 + 0,02 \cdot 266,28) = 216,20 \text{ kN/m}^2$$

Nos quedamos con el mayor valor, es decir $p = p_2$

Definimos “s” como el espacio entre longitudinales del fondo, que será de 1000 mm. En el pantoque tenemos un espacio entre refuerzos de 785 mm, por lo que nos quedaremos con el valor de los del fondo para dimensionar el espesor tanto del fondo como del pantoque.

Definimos "I" como la distancia entre bulárcamas que es: $0,925 \cdot 3 = 2,775$ m.

$$ka = \left(1,1 - 0,25 \frac{1}{0,925 \cdot 3}\right)^2 = 1,02$$

Definiremos Z_B como 1,2 veces Z_0 . Por tanto: $Z_B = 1,2 \cdot 46162951 = 55395542$ cm³.

De esta forma:

$$f_{2b} = \frac{5,7 \cdot 8078516}{55395542} = 0,8312$$

$$t_{requerido} = \frac{15,8 \cdot 1,02 \cdot 1 \cdot \sqrt{236,63}}{\sqrt{120 \cdot 1}} + 1,5 = 24,13 \text{ mm.} \rightarrow 25 \text{ mm.}$$

$$t_{mín} = 5 + \frac{0,04 \cdot 266,28}{\sqrt{1}} = 15,65 \text{ mm.} \rightarrow 16 \text{ mm.}$$

Tendremos un espesor tanto del fondo como del pantoque de 25 mm.

C700 Longitudinales del fondo

C 700 Bottom longitudinals

701 The section modulus requirement is given by:

$$Z = \frac{83 l^2 s p w_k}{\sigma} \quad (\text{cm}^3)$$

p = p₁ to p₃ (when relevant) as given in Table B1

σ = allowable stress (maximum 160 f₁) given by:

— within 0,4 L:

Single bottom	Double bottom
$225 f_1 - 130 f_{2b}$	$225 f_1 - 130 f_{2b} - 0,7 \sigma_{db}$

σ_{db} = mean double bottom stress at plate flanges, normally not to be taken less than:

- = 20 f₁ for cargo holds in general cargo vessels
- = 50 f₁ for holds for ballast
- = 85 f₁ b/B for tanks for liquid cargo

$$\sigma = 225 \cdot 1 - 130 \cdot f_{2b} - 0,7 \cdot \sigma_{db} = 225 \cdot 1 - 130 \cdot 0,8312 - 0,7 \cdot 50 \cdot 1 = 81,94$$

Cogemos $p = p_2 = 236,63 \text{ kN/m}^2$

Para calcular w_k : Pt 3 Ch. 1 Sec. 3 C.1000

1004 For stiffeners and girders in tanks and in cargo holds of dry bulk cargo carriers, corrosion additions corresponding to the requirements given in Sec.2 D are to be applied. For built up sections the appropriate t_k -value may be added to the web and flange thickness after fulfilment of the modulus requirement.

For rolled sections the section modulus requirement may be multiplied by a corrosion factor w_k , given by the following approximation:

$$w_k = 1 + 0,05 (t_{kw} + t_{kf}) \text{ for flanged sections} \\ = 1 + 0,06 t_{kw} \text{ for bulbs}$$

t_{kw} = corrosion addition t_k as given in Sec.2 D200 with respect to the profile web

t_{kf} = corrosion addition t_k as given in Sec.2 D200 with respect to the profile flange.

For flat bars the corrosion addition t_k may be added directly to the thickness.

$$w_k = 1 + 0,06 \cdot 1,5 = 1,09$$

El valor utilizado para la separación entre bulárcamas es de 2,775 m. Lo definimos en el cuaderno 4, ya que $3 \cdot 0,925 = 2,775$ (\rightarrow cofferdams).

$$Z = \frac{83 \cdot 2,775^2 \cdot 1 \cdot 236,63 \cdot 1,09}{81,94} = 2011,89 \text{ cm}^3$$

C730

$$t = 5,0 + \frac{k}{\sqrt{f_1}} + t_k \quad (\text{mm}) \\ = \frac{h}{g} + t_k$$

$$k = 0,02 L_1 \\ = 5,0 \text{ maximum} \\ h = \text{profile height in m} \\ g = 70 \text{ for flanged profile webs} \\ = 20 \text{ for flat bar profiles.}$$

El espesor es:

$$t = 5 + \frac{5}{\sqrt{1}} + 1,5 = 11,5 \text{ mm.} \rightarrow 12 \text{ mm.}$$

Para el valor del módulo obtenido $Z = 2011,89$ elegiremos un perfil con bulbo.

Doble fondo

Pt. 3 Ch. 1 Sec. 6

A201

$$f_{2b} = \frac{5,7(M_S + M_W)}{Z_B}$$

Ff_{2b} = 0,8312 (calculado anteriormente)

B201

Table B1 Design loads:		
Structure	Load type	p (kN/m ²)
Outer bottom	Sea pressure	p ₁ = 10 T + p _{dp} (kN/m ²) ¹⁾
	Net pressure in way of cargo tank or deep tank	p ₂ = ρ(g ₀ + 0,5 a _v) h _s - 10 T _M
p ₃ = ρg ₀ h _s + p ₀ - 10 T _M		
Inner bottom	Dry cargo in cargo holds	p ₄ = ρ(g ₀ + 0,5 a _v) H _C
	Ballast in cargo holds	p ₅ = (10 + 0,5 a _v) h _s
		p ₆ = 6,7(h _s + φb) - 1,2√(Hφb ₁) ²⁾
		p ₇ = 0,67(10h _p + Δp _{dyn})
Liquid cargo in tank above	p ₈ = 10h _s + p ₀	
Inner bottom, floors and girders	Pressure on tank boundaries in double bottom	p ₉ = ρ(g ₀ + 0,5 a _v) h _s
		p ₁₀ = ρg ₀ [0,67(h _s + φb) - 0,12√(Hφb ₁)] ²⁾
		p ₁₁ = 0,67(ρg ₀ h _p + Δp _{dyn})
	Minimum pressure	p ₁₂ = ρg ₀ h _s + p ₀
Inner bottom, floors and girders	Pressure on tank boundaries in double bottom	p ₁₃ = 0,67(10h _p + Δp _{dyn})
		p ₁₄ = 10h _s + p ₀
Minimum pressure		p ₁₅ = 10 T

1) For ships with service restrictions the last term in p₁ may be reduced by the percentages given in Sec.4 B302.
 2) p₆ and p₁₀ to be used in tanks/holds with largest breadth > 0,4 B.

Vamos a definir algunos parámetros:

-Hc: la distancia vertical en metros, desde el punto de la línea base hasta el extremo superior de la brazola.

-hp: la distancia horizontal en metros, desde el punto de cálculo hasta el extremo superior de la tubería de aireación.

-hs: distancia vertical en metros, desde el punto de cálculo a la parte superior del tanque.

-la densidad de nuestra carga es de 0.43 t/m³.

$$p_9 = 0,43 \cdot (9,81 + 0,5 \cdot 3,3708) \cdot 28,5 = 140,87 \text{ kN/m}^2$$

Para calcular el valor de φ vamos a Pt. 3 Ch.1 Sec. 4 B400:

B 400 Roll motion and acceleration

401 The roll angle (single amplitude) is given by:

$$\phi = \frac{50c}{B + 75} \quad (\text{rad})$$

$c = (1,25 - 0,025 T_R) k$

$k = 1,2$ for ships without bilge keel

$= 1,0$ for ships with bilge keel

$= 0,8$ for ships with active roll damping facilities

$T_R =$ as defined in 402, not to be taken greater than 30.

402 The period of roll is generally given by:

$$T_R = \frac{2k_r}{\sqrt{GM}} \quad (\text{s})$$

$k_r =$ roll radius of gyration in m

$GM =$ metacentric height in m.

The values of k_r and GM to be used are to give the minimum realistic value of T_R for the load considered.

In case k_r and GM have not been calculated for such condition, the following approximate design values may be used:

$k_r = 0,39 B$ for ships with even transverse distribution of mass

$= 0,35 B$ for tankers in ballast

$= 0,25 B$ for ships loaded with ore between longitudinal bulkheads

$GM = 0,07 B$ in general

$= 0,12 B$ for tankers and bulk carriers.

Tenemos:

$$T_R = \frac{2 \cdot 0,35 \cdot 43,2}{\sqrt{0,12 \cdot 43,2}} = 13,28 \text{ s}$$

$$\phi = \frac{50 \cdot (1,25 - 0,025 \cdot 13,28) \cdot 1}{43,2 + 75} = 0,3883$$

$$p_{10} = 0,43 \cdot 9,81 \left[0,67 \cdot (29 + 0,3883 \cdot 28,14) - 0,12 \cdot \sqrt{31,5 \cdot 0,3883 \cdot 25} \right]$$

$$= 102,57 \text{ kN/m}^2$$

$$p_{11} = 0,67 \cdot (0,43 \cdot 9,81 \cdot 27,18 + 25) = 93,56 \text{ kN/m}^2$$

$$p_{12} = 0,43 \cdot 9,81 \cdot 29 + 25 = 147,33 \text{ kN/m}^2$$

$$p_{13} = 0,67 \cdot (10 \cdot 27,18 + 25) = 198,856 \text{ kN/m}^2$$

$$p_{15} = 10 \cdot 12,60 = 126 \text{ kN/m}^2$$

Cogemos el mayor valor de la presión, $p = p_{13} = 198,856 \text{ kN/m}^2$

$$ka = \left(1,1 - 0,25 \frac{1}{0,925 \cdot 3}\right)^2 = 1,02$$

C 400 Inner bottom plating

401 The thickness requirement corresponding to lateral pressure is given by:

$$t = \frac{15,8 k_a s \sqrt{p}}{\sqrt{\sigma}} + t_k \quad (\text{mm})$$

$$t_{req} = \frac{15,8 \cdot 1,02 \cdot 1 \cdot \sqrt{198,856}}{\sqrt{140 \cdot 1}} + 1,5 = 20,70 \text{ mm.} \rightarrow 21 \text{ mm.}$$

402 The thickness is not to be less than:

$$t = t_0 + \frac{0,03 L_1}{\sqrt{f_1}} + t_k \quad (\text{mm})$$

- $t_0 = 7,0$ in holds below dry cargo hatchway opening if ceiling is not fitted.
- $= 6,0$ elsewhere in holds if ceiling is not fitted
- $= 5,0$ in general if ceiling is fitted.
- $= 5,0$ in void spaces, machinery spaces and tanks.

$$t_{min} = 5 + \frac{0,03 \cdot 266,28}{\sqrt{1}} + 1,5 = 14,48 \text{ mm.} \rightarrow 15 \text{ mm.}$$

El doble fondo tendrá un espesor de 21 mm.

C800 Longitudinales del doble fondo

C 800 Inner bottom longitudinals

801 The section modulus requirement is given by:

$$Z = \frac{83 l^2 s p w_k}{\sigma} \quad (\text{cm}^3)$$

Utilizaremos la tabla de B201. Los valores de las presiones están calculados en el apartado anterior. Cogemos el valor de la mayor presión. $P = p_{13} = 198,856 \text{ kN/m}^2$.

$$wk = 1 + 0,06 \cdot 1,5 = 1,09$$

$$\sigma = 225 \cdot 1 - 130 \cdot f_{2b} - 0,7 \cdot \sigma_{db} = 225 \cdot 1 - 130 \cdot 0,8312 - 0,7 \cdot 50 \cdot 1 = 81,94$$

802 The thickness of web and flange is not to be less than the larger of:

$$t = 5,0 + \frac{k}{\sqrt{f_1}} + t_k \quad (\text{mm})$$

$$t_{\min} = 5,0 + \frac{5}{1} + 1,5 = 11,5 \text{ mm.} \rightarrow 12 \text{ mm.}$$

Los refuerzos del doble fondo y de la tolva interior del tanque tendrán estas características.

C500 Vagras del fondo

C 500 Plating in double bottom floors and longitudinal girders

501 The thickness requirement of floors and longitudinal girders forming boundaries of double bottom tanks is given by:

$$t = \frac{15,8 k_2 s \sqrt{p}}{\sqrt{\sigma}} + t_k \quad (\text{mm})$$

p = p_{13} to p_{15} (when relevant) as given in Table B1

p = p_1 for sea chest boundaries (including top and partial bulkheads)

σ = allowable stress, for longitudinal girders within 0,4L given by:

<i>Transversely stiffened</i>	<i>Longitudinally stiffened</i>
$190 f_1 - 120 f_{10}$, maximum $130 f_1$	$130 f_1$

σ = $160 f_1$ within 0,1L from the perpendiculars and for floors in general

= $120 f_1$ for sea chest boundaries (including top and partial bulkheads)

Para nuestro caso utilizaremos $130 \cdot f_1 = 130 \text{ N/mm}^2$.

$$ka = \left(1,1 - 0,25 \cdot \frac{3}{0,925 \cdot 3} \right)^2 = 0,6884$$

$$P_0 = 25 \text{ kN/m}^2$$

Calculamos p_{13} , p_{14} y p_{15}

-hp: distancia vertical en metros, desde el punto de cálculo hasta el extremo superior de la tubería de aireación.

-hs: distancia vertical en metros, desde el punto de cálculo a la parte superior del tanque.

-Para tanques de lastre cogemos $\Delta p_{dyn} = 25 \text{ kN/m}^2$ (Pt. 3 Ch. 1 Sec. 4 C300)

Guidance note:

If the pressure drop according to Pt.4 Ch.6 Sec.4 K201 is not available, p_{dyn} may normally be taken as 25 kN/m^2 for ballast tanks and zero for other tanks. If arrangements for the prevention of overpumping of ballast tanks in accordance with Pt.4 Ch.6 Sec.4 K200 are fitted, p_{dyn} may be taken as zero.

$$p_{13} = 0,67 \cdot (10h_p + \Delta p_{dyn}) = 0,67 \cdot (10 \cdot 27,18 + 25) = 198,85 \text{ kN/m}^2$$

$$p_{14} = 10 \cdot 29 + 25 = 292 \text{ kN/m}^2$$

$$p_{15} = 10 \cdot 12,5 = 125 \text{ kN/m}^2$$

Nos quedamos con el mayor valor, $p = p_{14} = 292 \text{ kN/m}^2$.

$$t_{req} = \frac{15,8 \cdot 0,6884 \cdot \sqrt{292}}{\sqrt{130}} + 1,5 = 17,80 \text{ mm.} \rightarrow 18 \text{ mm.}$$

502 The thickness of longitudinal girders, floors, supporting plates and brackets is not to be less than:

$$t = 6,0 + \frac{k}{\sqrt{f_1}} + t_k \quad (\text{mm})$$

- $k = 0,04 L_1$ for centre girder up to 2 m above keel plate
- $= 0,02 L_1$ for other girders and remaining part of centre girder
- $= 0,05 L_1$ for sea chest boundaries (including top and partial bulkheads).

Sustituyendo, tenemos:

$$t_{min} = \frac{6 + 0,04 \cdot 266,28}{\sqrt{1}} + 1,5 = 18,15 \text{ mm.} \rightarrow 19 \text{ mm.}$$

Por tanto, las vagras no estancas tendrán un espesor de 19 mm.

Pt. 3 Ch. 1 Sec. 9**C101 Vagra estanca doble fondo****C 100 Bulkhead plating**

101 The thickness requirement corresponding to lateral pressure is given by:

$$t = \frac{15,8k_a s \sqrt{p}}{\sqrt{\sigma}} + t_k \quad (\text{mm})$$

p = $p_1 - p_9$, whichever is relevant, as given in Table B1

σ = $160 f_1$ for longitudinally stiffened longitudinal bulkhead plating at neutral axis irrespective of ship length

= $140 f_1$ for transversely stiffened longitudinal bulkhead plating at neutral axis within 0.4 L amidships, may however be taken as $160 f_1$ when p_6 or p_7 are used.

El valor más desfavorable de la presión lo obtenemos de p_3 :

$$p_3 = \rho \cdot (g_0 + 0,5 \cdot a_V) \cdot h_s = 1,025 \cdot (9,81 + 0,5 \cdot 3,3708) \cdot (26,3 + 0,76) \\ = 318,84 \text{ kN/m}^2$$

$$k_a = \left(1,1 - 0,25 \frac{0,625}{0,925 \cdot 3} \right)^2 = 1,089$$

$$t = \frac{15,8 \cdot 1,089 \cdot 0,625 \cdot \sqrt{318,84}}{\sqrt{140 \cdot 1}} + 1,5 = 17,71 \text{ mm.} \rightarrow 18 \text{ mm.}$$

Tomaremos un espesor de 18 mm.

C900 Refuerzos de la vagra estanca**C 900 Stiffening of double bottom floors and girders**

901 The section modulus requirement of stiffeners on floors and longitudinal girders forming boundary of double bottom tanks is given by:

$$Z = \frac{100 l^2 s p w_k}{\sigma} \quad (\text{cm}^3)$$

Utilizaremos la tabla de B201. Los valores de las presiones están calculados en el apartado anterior. Cogemos el valor de la mayor presión. $P = p_3 = 318,84 \text{ kN/m}^2$.

$$w_k = 1 + 0,06 \cdot 1,5 = 1,09$$

$$\sigma = 225 \cdot 1 - 110 \cdot f_{2b} = 225 \cdot 1 - 110 \cdot 0,831 = 133,59 \text{ N/mm}^2$$

$$Z = \frac{100 \cdot 2,775^2 \cdot 0,833 \cdot 318,84 \cdot 1,09}{133,59} = 1668,77 \text{ cm}^3$$

Pt. 3 Ch. 1 Sec. 8

C100 Cubierta resistente (cubierta superior o principal)

C 100 Strength deck plating

101 The breadth of stringer plate and strakes in way of possible longitudinal bulkheads which are to be of grade B, D or E is not to be less than:

$$b = 800 + 5 L \text{ (mm), maximum 1800 mm.}$$

102 The thickness requirement corresponding to lateral pressure is given by:

$$t = \frac{15,8 k_s \sqrt{p}}{\sqrt{\sigma}} + t_k \text{ (mm)}$$

Table B1 Design loads		
Structure	Load type	p (kN/m ²)
Weather decks ¹⁾	Sea pressure	$p_1 = a(p_{dp} - (4 + 0,2k_s)h_0)^2$, minimum 5,0
	Deck cargo	$p_2 = (\xi_0 + 0,5 a_v) q$
Cargo tweendecks	Deck cargo	$p_3 = \rho_c (\xi_0 + 0,5 a_v) H_C$
Platform deck in machinery spaces	Machinery and equipment	$p_4 = 1,6 (\xi_0 + 0,5 a_v)$
Accommodation decks	Accommodation in general	$p_5 = 0,35 (\xi_0 + 0,5 a_v)$, see also Sec.4 C401
Deck as tank bottom in general	Ballast, bunker or liquid cargo	$p_6 = \rho (\xi_0 + 0,5 a_v) h_s$
Deck as tank top in general		$p_7 = 0,67 (\rho \xi_0 h_p + \Delta P_{dyn})$
		$p_8 = \rho \xi_0 h_s + p_0$
Deck as tank boundary in tanks with breadth > 0,4 B		$p_9 = \rho \xi_0 [0,67(h_s + \phi b) - 0,12 \sqrt{H \phi b}]$
Deck as tank boundary towards ends of tanks with length > 0,15 L		$p_{10} = \rho \xi_0 [0,67(h_s + \theta l) - 0,12 \sqrt{H \theta l}]$
Deck as tank boundary in tanks with breadth > 0,4 B ³⁾		$p_{11} = \rho \left(3 - \frac{B}{100}\right) b_b$
Deck as tank boundary in tanks with length > 0,1 L ⁴⁾		$p_{12} = \rho \left(4 - \frac{L}{200}\right) l_b$
Watertight decks submerged in damaged condition ⁵⁾	Sea pressure	$p_{13} = 10 h_b$

1) On weather decks combination of the design pressures p_1 and p_2 may be required for deck cargo with design stowage height less than 2,3 m.
 2) For ships with service restrictions p_1 may be reduced with the percentages given in Sec.4 B202. C_w should not be reduced
 3) To be used for strength members located less than $0,25 b_b$ away from tank sides in tanks with no restrictions on their filling height. For tanks with free breadth (no longitudinal wash bulkheads) $b_b > 0,56 B$ the design pressure will be specially considered according to Sec.4 C305
 4) To be used for strength members located less than $0,25 l_b$ away from tank ends in tanks with no restrictions on their filling height. For tanks with free length (no transverse wash bulkheads or transverse web frames in narrow tanks) $l_b > 0,13 L$ the design pressure will be specially considered according to Sec.4 C305
 5) The strength may be calculated with allowable stresses for plating, stiffeners and girders increased by 60 %.

$$p_{dp} = 29,484 + 135 \cdot \frac{21,6}{43,2 + 75} - 1,2(12,5 - 12,5) = 54,15 \text{ kN/m}^2$$

$$p_1 = 0,8 \cdot (54,15 - (4 + 0,2 \cdot 2) \cdot 20) = -27,08 \text{ kN/m}^2$$

$$p_7 = 0,67 \cdot (1,025 \cdot 9,81 \cdot 0 + 25) = 16,75 \text{ kN/m}^2$$

$$p_8 = 1,025 \cdot 9,81 \cdot 0 + 25 = 25 \text{ kN/m}^2$$

Según Pt. 3 Ch. 1 Sec. 4 B501:

$$\theta = 0,25 \cdot \frac{0,366}{0,69} = 0,132 \text{ rad}$$

$$p_{10} = 1,025 \cdot 9,81 \cdot \left[0,67 \cdot (0 + 0,132 \cdot 2,15) - 0,12 \cdot \sqrt{26,3 \cdot 0,132 \cdot 4,65} \right] \\ = -151,53 \text{ kN/m}^2$$

$$p_{12} = 1,025 \cdot \left(4 - \frac{266,28}{200} \right) \cdot 46,25 = 126,50 \text{ kN/m}^2$$

Cogemos $p = p_{12} = 126,50 \text{ kN/m}^2$

$$t_{requerido} = \frac{15,8 \cdot 1,02 \cdot 0,881 \cdot \sqrt{126,50}}{\sqrt{120} \cdot 1} + 2,5 = 17,11 \text{ mm.} \rightarrow 18 \text{ mm.}$$

104 The thickness is not to be less than:

$$t = t_0 + \frac{k L_1}{\sqrt{f_1}} + t_k \quad (\text{mm})$$

$$t_{min} = 5,5 + \frac{0,01 \cdot 266,28}{\sqrt{1}} = 10,66 \text{ mm.} \rightarrow 11 \text{ mm.}$$

El espesor de la cubierta superior será de 18 mm.

C300 Longitudinales de cubierta superior**C 300 Longitudinals**

301 The section modulus requirement is given by:

$$Z = \frac{83 I^2 s p w_k}{\sigma} \quad (\text{cm}^3), \quad \text{minimum } 15 \text{ cm}^3$$

Deck	σ
Strength deck, long superstructures and effective deckhouses above strength deck	$225 f_1 - 130 f_{2d}$ maximum $160 f_1$
Continuous decks below strength deck	$225 f_1 - 130 f_{2d} \frac{z_a - z_b}{z_a}$ maximum $160 f_1$

Definiremos Z_B como 1,2 veces Z_0 . Por tanto: $Z_B = 1,2 \cdot 46162951 = 55395542 \text{ cm}^3$.

$$f_{2b} = \frac{5,7 \cdot 8078516}{55395542} = 0,8312$$

$$\sigma = 225 \cdot 1 - 130 \cdot f_{2b} = 225 \cdot 1 - 130 \cdot 0,831 = 116,97 \text{ N/mm}^2$$

$$wk = 1 + 0,06 \cdot 1,5 = 1,09$$

Cogeremos el valor para p calculado en el apartado anterior ($126,50 \text{ kN/m}^2$).

$$Z = \frac{83 \cdot 2,775^2 \cdot 0,881 \cdot 126,5 \cdot 1,09}{116,97} = 663,77 \text{ cm}^3$$

303 The web and flange thickness is not to be less than the larger of:

$$t = 5,0 + \frac{k}{\sqrt{f_1}} + t_k \quad (\text{mm})$$

$$t_{min} = 5 + \frac{0,01 \cdot 266,28}{\sqrt{1}} + 2,5 = 10,16 \text{ mm.} \rightarrow 11 \text{ mm.}$$

Los refuerzos longitudinales de la cubierta superior tendrán estas características.

D100 Vagras de la cubierta superior**Pt. 3 Ch. 1 Sec. 8****D 100 General**

101 The thickness of web plates, flanges, brackets and stiffeners of girders is not to be less than:

$$t = 5,0 + \frac{k}{\sqrt{F_1}} + t_k \quad (\text{mm})$$

k = 0,01 L₁ in general
 = 0,02 L₁ for girder webs, flanges and brackets in cargo oil tanks and ballast tanks in cargo area
 = 0,03 L₁ (= 6,0 maximum) for girder webs, flanges and brackets in peaks.

$$t_{min} = 5 + \frac{0,02 \cdot 266,28}{\sqrt{1}} + 1,5 = 11,82 \text{ mm.} \rightarrow 12 \text{ mm.}$$

Las vagras de la cubierta superior tendrán un espesor de 12 mm.

4-MOMENTOS FLECTORES, FUERZAS CORTANTES, MÓDULO E INERCIA**Solicitaciones en aguas tranquilas por reglamento**

Según el DNV Pt. 3 Ch. 1 Sec. 5 B105:

105 The design values of stillwater shear forces along the length of the ship are normally not to be taken less than:

$$Q_S = k_{sq} Q_{SO} \quad (\text{kN})$$

$$Q_{SO} = 5 \frac{M_{SO}}{L} \quad (\text{kN})$$

M_{SO} = design stillwater bending moments (sagging or hogging) given in 103.

103 The design stillwater bending moments amidships (sagging and hogging) are normally not to be taken less than:

$$M_S = M_{SO} \quad (\text{kNm})$$

M_{SO} = -0,065 C_{WU} L² B (C_B + 0,7) (kNm) in sagging
 = C_{WU} L² B (0,1225 - 0,015 C_B) (kNm) in hogging
 C_{WU} = C_W for unrestricted service.

En arrufo:

$$M_{SO} = -0,065 C_{WU} L^2 B (C_B + 0,7)$$

En quebranto:

$$M_{SO} = C_{WU} L^2 B (0,1225 - 0,015 C_B)$$

Donde:

$$\begin{aligned}
 k_{sq} &= 0 \text{ at A.P. and F.P.} \\
 &= 1,0 \text{ between } 0,15 L \text{ and } 0,3 L \text{ from A.P.} \\
 &= 0,8 \text{ between } 0,4 L \text{ and } 0,6 L \text{ from A.P.} \\
 &= 1,0 \text{ between } 0,7 L \text{ and } 0,85 L \text{ from A.P.}
 \end{aligned}$$

$$M_S = k_{sm} M_{SO} \text{ (kNm)}$$

$$\begin{aligned}
 M_{SO} &= \text{as given in 103} \\
 k_{sm} &= 1,0 \text{ within } 0,4 L \text{ amidships} \\
 &= 0,15 \text{ at } 0,1 L \text{ from A.P. or F.P.} \\
 &= 0,0 \text{ at A.P. and F.P.}
 \end{aligned}$$

Y para hallar C_w vamos a Pt. 4 Ch. 1 Sec. 4 B 201:

B 200 Basic parameters

201 The acceleration, sea pressures and hull girder loads have been related to a wave coefficient as given in Table B1.

L	C_w
$L \leq 100$	$0,0792 L$
$100 < L < 300$	$10,75 - [(300-L)/100]^{3/2}$
$300 \leq L \leq 350$	$10,75$
$L > 350$	$10,75 - [(L-350)/150]^{3/2}$

$$C_w = 10,75 - \left[\frac{300 - L}{100} \right]^{3/2} = 10,55$$

$C_{wu} = C_w$, por tanto, tendremos:

$$M_{SO}(\text{arrufo}) = -3.000.592 \text{ kN} \cdot \text{m}$$

$$M_{SO}(\text{quebranto}) = 3.605.542 \text{ kN} \cdot \text{m}$$

$$Q_{SO}(\text{arrufo}) = -56.343 \text{ kN}$$

$$Q_{SO}(\text{quebranto}) = 67.703 \text{ kN}$$

Cálculo de solicitaciones por ola

Momentos flectores

Según el reglamento Pt. 3 Ch. 1 Sec 5 B201 y B203.

201 The rule vertical wave bending moments amidships are given by:

$$M_W = M_{W0} \text{ (kNm)}$$

$$M_{W0} = -0,11 \alpha C_W L^2 B (C_B + 0,7) \text{ (kNm) in sagging}$$

$$= 0,19 \alpha C_W L^2 B C_B \text{ (kNm) in hogging}$$

$$\alpha = 1,0 \text{ for seagoing conditions}$$

$$= 0,5 \text{ for harbour and sheltered water conditions (enclosed fjords, lakes, rivers).}$$

203 The rule values of vertical wave shear forces along the length of the ship are given by:

Positive shear force, to be used when positive still water shear force:

$$Q_{WP} = 0,3 \beta k_{wqp} C_W L B (C_B + 0,7) \text{ (kN)}$$

Negative shear force, to be used when negative still water shear force:

$$Q_{WN} = -0,3 \beta k_{wnq} C_W L B (C_B + 0,7) \text{ (kN)}$$

Positive shear force when there is a surplus of buoyancy forward of section considered, see also Fig. 1.

Negative shear force when there is a surplus of weight forward of section considered.

$$\beta = 1,0 \text{ for seagoing conditions}$$

$$= 0,5 \text{ for harbour and sheltered water conditions (enclosed fjords, lakes, rivers)}$$

$$k_{wqp} = 0 \text{ at A.P. and F.P.}$$

$$= 1,59 C_B / (C_B + 0,7) \text{ between } 0,2 L \text{ and } 0,3 L \text{ from A.P.}$$

$$= 0,7 \text{ between } 0,4 L \text{ and } 0,6 L \text{ from A.P.}$$

$$= 1,0 \text{ between } 0,7 L \text{ and } 0,85 L \text{ from A.P.}$$

$$k_{wnq} = 0 \text{ at A.P. and F.P.}$$

$$= 0,92 \text{ between } 0,2 L \text{ and } 0,3 L \text{ from A.P.}$$

$$= 0,7 \text{ between } 0,4 L \text{ and } 0,6 L \text{ from A.P.}$$

$$= 1,73 C_B / (C_B + 0,7) \text{ between } 0,7 L \text{ and } 0,85 L \text{ from A.P.}$$

$$C_W = \text{as given in 201.}$$

$$M_{W0}(\text{arrufo}) = -5.077.925 \text{ kN} \cdot \text{m}$$

$$M_{W0}(\text{quebranto}) = 8.770.961 \text{ kN} \cdot \text{m}$$

Fuerzas cortantes

Según Pt. 3 Ch. 1 Sec. 5 B203:

$$Q_{WP} = 36.407 \text{ kN}$$

$$Q_{WN} = -36.407 \text{ kN}$$

Módulo e inercia de la cuaderna maestra

El módulo mínimo de la maestra según Pt. 3 Ch. 1 Sec. 5 C302

302 The midship section modulus about the transverse neutral axis is not to be less than:

$$Z_0 = \frac{C_{W0}}{f_1} L^2 B (C_B + 0,7) \text{ (cm}^3\text{)}$$

El módulo requerido e según según Pt. 3 Ch. 1 Sec. 5 C303

303 The section modulus requirements about the transverse neutral axis based on cargo and ballast conditions are given by:

$$Z_0 = \frac{|M_S + M_W|}{\sigma_i} \cdot 10^3 \quad (\text{cm}^3)$$

$$\begin{aligned} \sigma_i &= 175 f_1 \text{ N/mm}^2 \text{ within } 0,4 L \text{ amidship} \\ &= 125 f_1 \text{ N/mm}^2 \text{ within } 0,1 L \text{ from A.P. or F.P.} \end{aligned}$$

Between specified positions σ_i is to be varied linearly.

La inercia mínima según Pt. 3 Ch. 1 Sec. 5 C401

C 400 Moment of inertia

401 The midship section moment of inertia about the transverse neutral axis is not to be less than:

$$I = 3 C_W L^3 B (C_B + 0,7) \quad (\text{cm}^4)$$

Por tanto, tendremos que:

$$I = 36.876.810.427 \text{ cm}^4$$

Cambiando las unidades tenemos:

$$I = 3.687.681,0427 \text{ cm}^2 \cdot \text{m}^2$$

Para nuestros cálculos $M_s = M_{so}$ y $M_w = M_{wo}$, así que el módulo requerido será:

$$Z_0 = \frac{|M_{so} + M_{wo}|}{175 \cdot 1} \cdot 10^3 = 46162951 \text{ cm}^3 = 461629 \text{ cm}^2 \cdot \text{m}$$

Y el módulo mínimo de la maestra será:

$$Z_0 = 46162949 \text{ cm}^3 = 461629 \text{ cm}^2 \cdot \text{m}$$

La ecuación la podemos ver en la imagen superior, siendo f_1 igual a 1.

5-RESISTENCIA LONGITUDINAL

Anteriormente hemos calculado por reglamento los máximos momentos flectores y fuerzas cortantes de nuestro buque en aguas tranquilas y por olas.

En el software Maxsurf, calculamos para cada una de nuestras condiciones de carga la resistencia longitudinal en el módulo "Longitudinal Strength", de manera que obtenemos los momentos flectores y fuerzas cortantes de cada una de nuestras condiciones de carga. Todos los datos de las mismas se adjuntan en el repot anexo. Podemos ver que en cada una de las condiciones, cumplimos con los máximos momentos flectores y fuerzas cortantes.

Vamos a aportar un resumen de cada una de ellas y posteriormente vemos las gráficas

de resistencia longitudinal.

Condición de carga 1: Salida de puerto a plena carga

CC1		%	Peso (t)
Rosca			36.099
Carga		97	62094,911
Consumos			
	Fuel Alm. (2x)	100	4645,316
	Fuel Sed. (2x)	100	279,08
	Fuel UD (2x)	100	185,566
	Diesel (2x)	100	765,746
	Aceite (2x)	100	98,834
	Agua dulce (2x)	100	153,59
	Aguas gr.	0	0
	Lodos	0	0
Lastre		0	
Viveres		100	4,375
Pesos fijos			105,25
TOTAL Δ			104.432

Condición de carga 2: Salida de puerto en lastre

CC2		%	Peso (t)
Rosca			36.099
Carga		0	0
Consumos			
	Fuel Alm. (2x)	100	4645,316
	Fuel Sed. (2x)	100	279,08
	Fuel UD (2x)	100	185,566
	Diesel (2x)	100	765,746
	Aceite (2x)	100	98,834
	Agua dulce (2x)	100	153,59
	Aguas gr.	0	0
	Lodos	0	0
Lastre		100	55265,135
Viveres		100	4,375
Pesos fijos			105,25
TOTAL Δ			97.602

Condición de carga 3: Llegada a puerto a plena carga

CC3		%	Peso (t)
Rosca			36.099
Carga		97	62094,911
Consumos			
	Fuel Alm. (2x)	0	0
	Fuel Sed. (2x)	91,87	256,39
	Fuel UD (2x)	100	185,566
	Diesel (2x)	10 (5+5)	38,288
	Aceite (2x)	10 (5+5)	4,942
	Agua dulce (2x)	10 (5+5)	7,68
	Aguas gr.	100	238,468
	Lodos	100	113,158
Lastre		0	
Viveres		10	0,4375
Pesos fijos			105,25
TOTAL Δ			99.144

Condición de carga 4: Llegada a puerto en lastre

CC4		%	Peso (t)
Rosca			36.099
Carga		0	0
Consumos			
	Fuel Alm. (2x)	0	0
	Fuel Sed. (2x)	91,87	256,39
	Fuel UD (2x)	100	185,566
	Diesel (2x)	10 (5+5)	38,288
	Aceite (2x)	10 (5+5)	4,942
	Agua dulce (2x)	10 (5+5)	7,68
	Aguas gr.	100	238,468
	Lodos	100	113,158
Lastre		100	55265,135
Viveres		10	0,4375
Pesos fijos			105,25
TOTAL Δ			92.315

Condición de carga 1

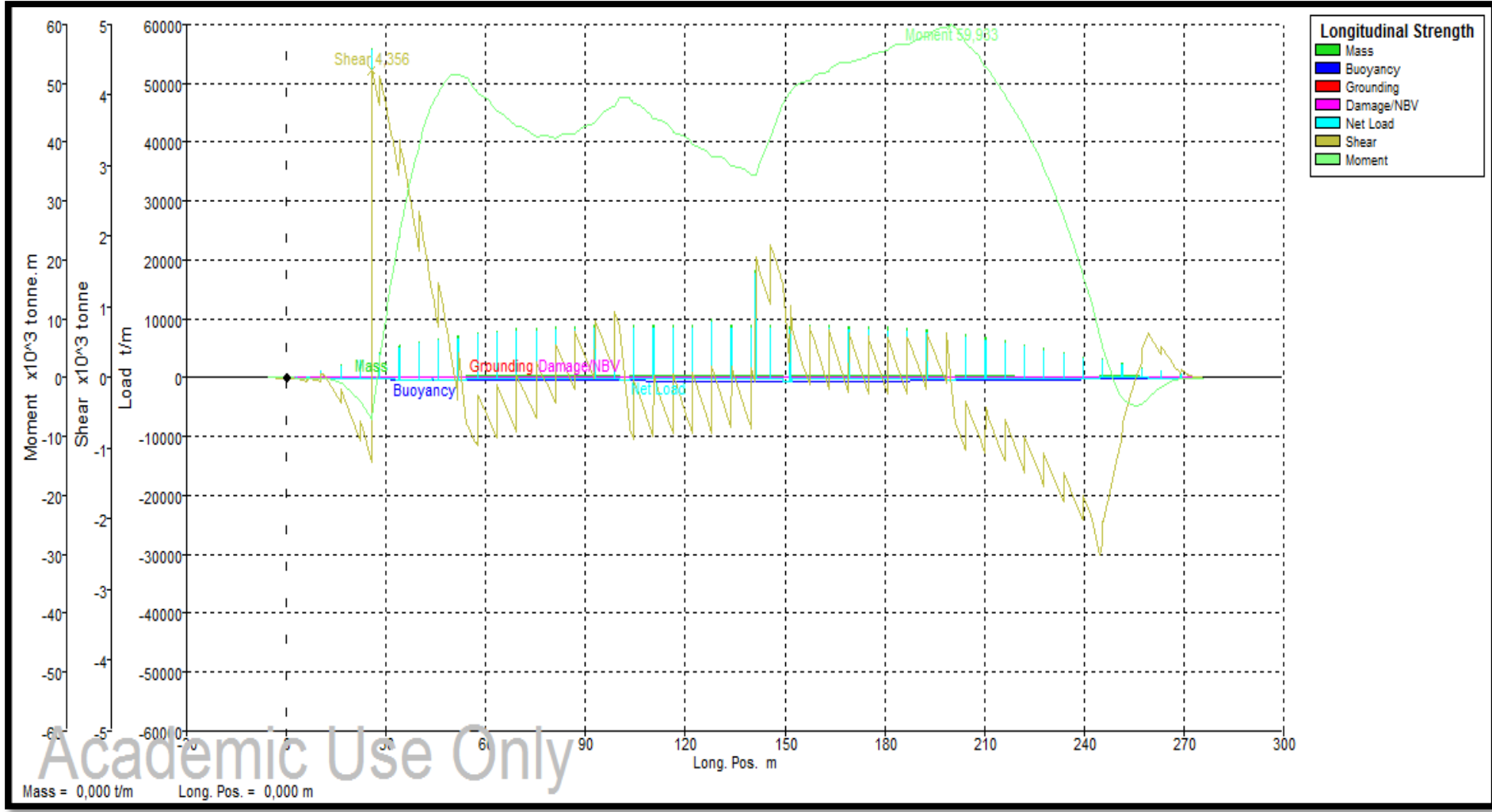

Condición de carga 2

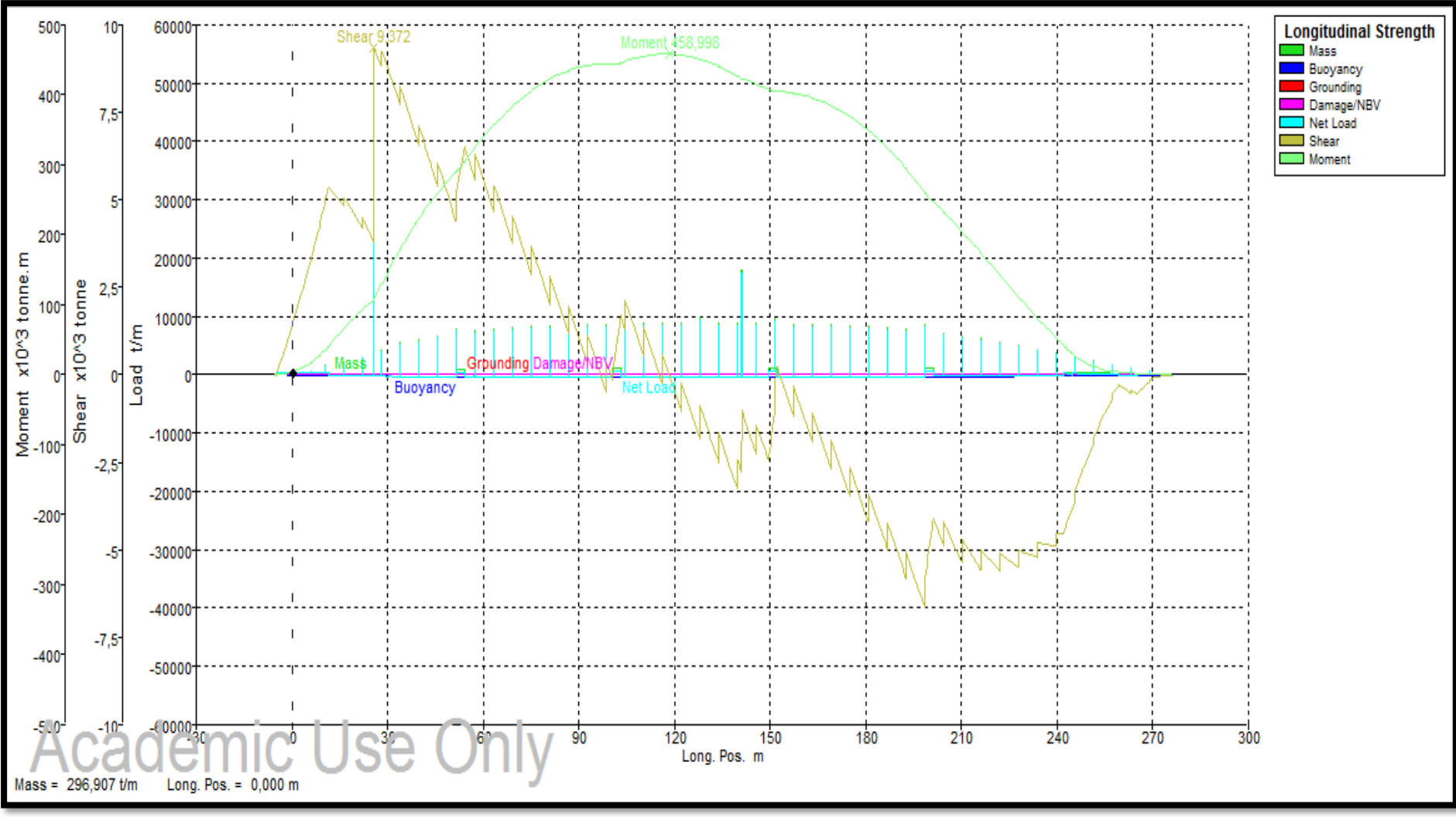

Condición de carga 3

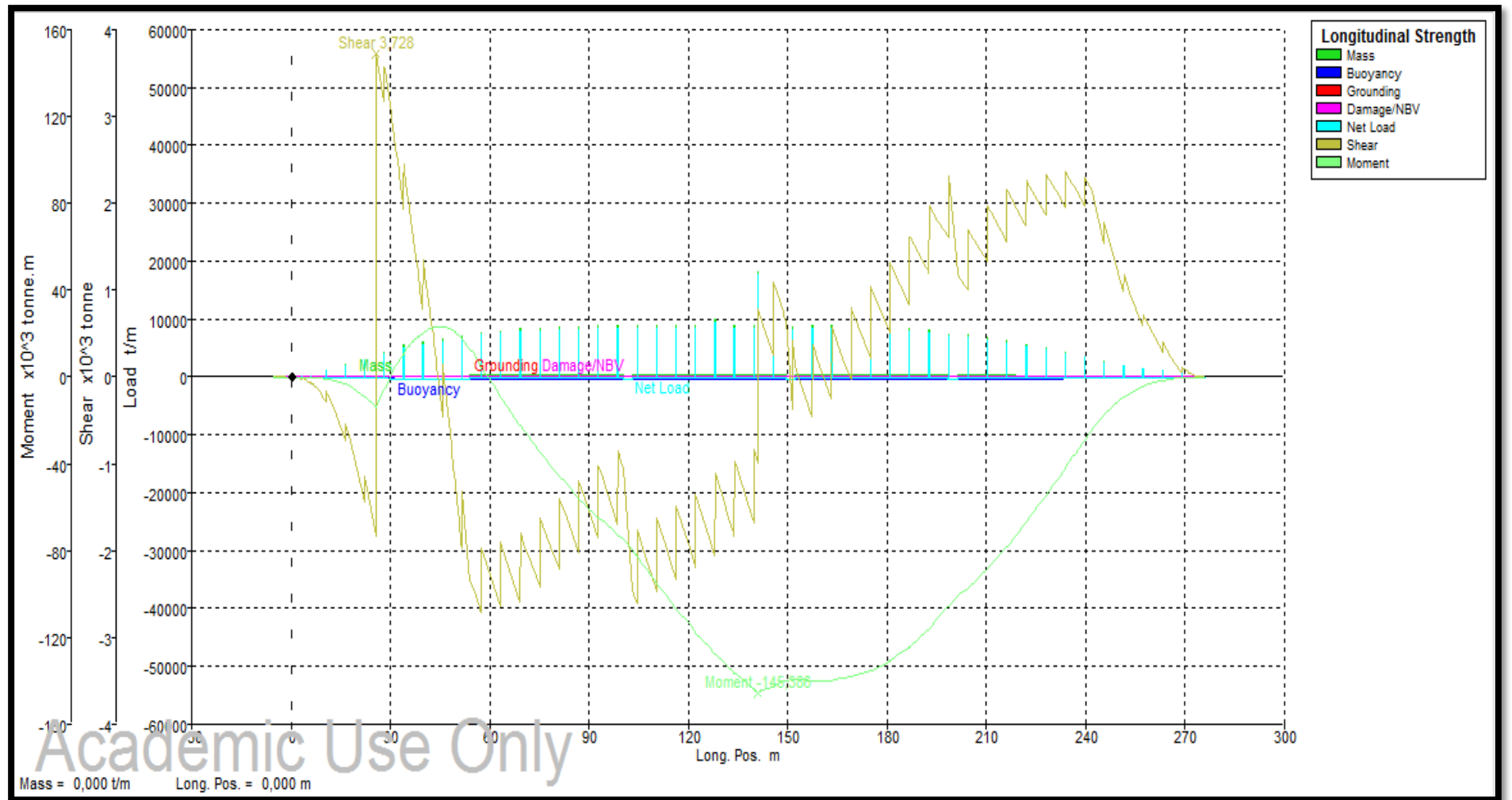

Condición de carga 4

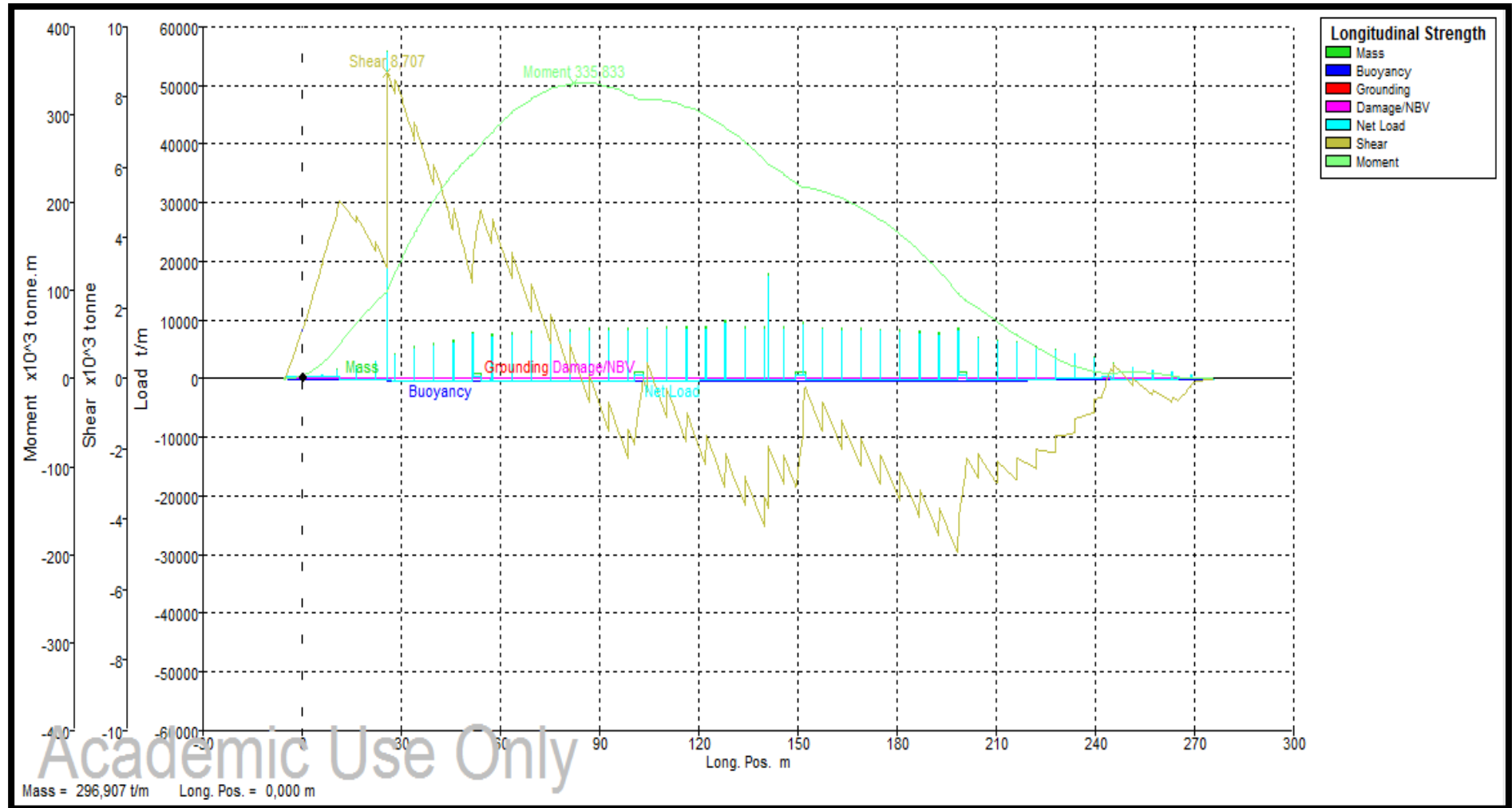

6-BIBLIOGRAFÍA

-Reglamento Sociedad de Clasificación DNV.

-Apuntes asignatura “Métodos Computacionales Aplicados al Proyecto del Buque”,
EPS Ferrol.

ANEXO I

Plano cuaderna maestra

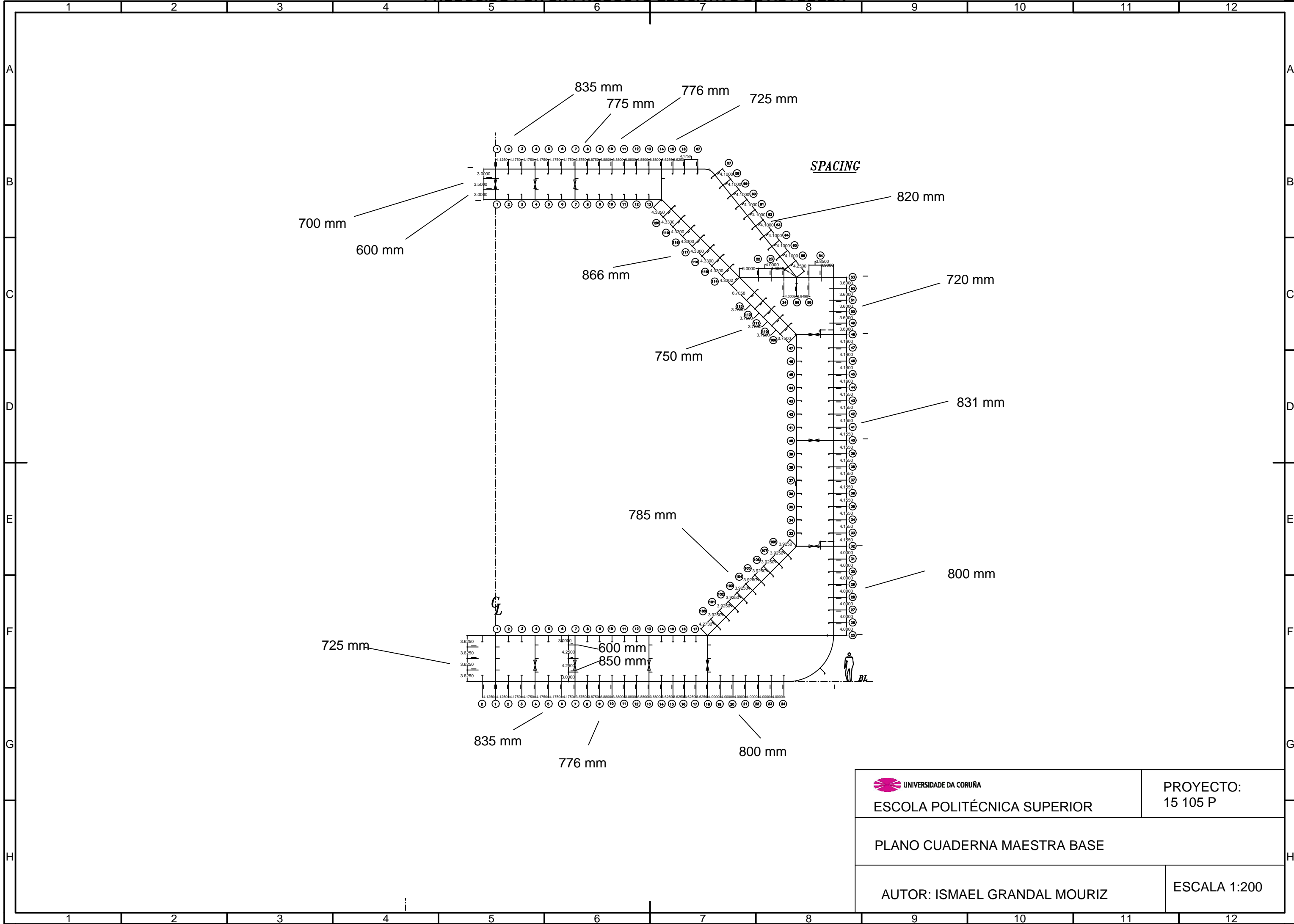

 UNIVERSIDADE DA CORUÑA ESCOLA POLITÉCNICA SUPERIOR	PROYECTO: 15 105 P
	PLANO CUADERNA MAESTRA BASE
AUTOR: ISMAEL GRANDAL MOURIZ	
ESCALA 1:200	

ANEXO II

Reglamento DNV

SECTION 5 LONGITUDINAL STRENGTH

A. General

A 100 Introduction

101 In this section the requirements regarding the longitudinal hull girder scantlings with respect to bending and shear are given.

102 The wave bending moments and shear forces are given as the design values with a probability of exceedance of 10^{-8} .

These values are applied when determining the section modulus and the shear area of the hull girder and in connection with control of buckling and ultimate strength. Reduced values will have to be used when considering combined local and longitudinal stresses in local elements, see B204.

103 The buckling strength of longitudinal members is not covered by this section. Requirements for such control are given in Sec.13.

104 For ships with small block coefficient, high speed and large flare the hull girder buckling strength in the forebody may have to be specially considered based on the distribution of still water and vertical wave bending moments indicated in B100 and B200 respectively. In particular this applies to ships with length $L > 120$ m and speed $V > 17$ knots.

105 For narrow beam ships the combined effects of vertical and horizontal bending of the hull girder may have to be specially considered as indicated in C300.

106 For ships with large deck openings (total width of hatch openings in one transverse section exceeding 65% of the ship's breadth or length of hatch opening exceeding 75% of hold length) the longitudinal strength including torsion may be required to be considered as given in Pt.5 Ch.2 Sec.6 B200. For ships with block coefficient $C_B < 0.7$ the longitudinal/local strength outside of the midship region may, subject to special consideration in each case, be taken according to Pt.5 Ch.2 Sec.6 B.

107 In addition to the limitations given in 104 to 106, special considerations will be given to vessels with the following proportions:

$$L/B \leq 5$$

$$B/D \geq 2.5.$$

A 200 Definitions

201 Symbols:

I_N = moment of inertia in cm^4 about the transverse neutral axis

I_C = moment of inertia in cm^4 about the vertical neutral axis

C_W = wave coefficient as given in Sec.4 B

S_N = first moment of area in cm^3 of the longitudinal material above or below the horizontal neutral axis, taken about this axis

z_n = vertical distance in m from the baseline or deckline to the neutral axis of the hull girder, whichever is relevant

z_a = vertical distance in m from the baseline or deckline to the point in question below or above the neutral axis, respectively

M_S = design stillwater bending moment in kNm as given in B100

Q_S = design stillwater shear force in kN as given in B100

M_W = rule wave bending moment in kNm as given in B200

Q_W = rule wave shear force in kN as given in B200

M_{WH} = rule wave bending moment about the vertical axis as given in B205

M_{WT} = rule wave torsional moment as given in B206.

202 Terms:

Effective longitudinal bulkhead is a bulkhead extending from bottom to deck and which is connected to the ship's side by transverse bulkheads both forward and aft.

Loading manual is a document which describes:

- the loading conditions on which the design of the ship has been based, including permissible limits of still water bending moment and shear force and shear force correction values and, where applicable, permissible

- limits related to still water torsional moment ¹⁾ and lateral loads
- the results of calculations of still water bending moments, shear forces and still water torsional moments if unsymmetrical loading conditions with respect to the ships centreline
- the allowable local loadings for the structure (hatch covers, decks, double bottom, etc.).

1) Permissible torsional still water moment limits are generally applicable for ships with large deck openings as given in 106 and class notation **CONTAINER** or **Container Carrier**.

For bulk carriers of 150 m in length and above, additional requirements as given in Pt.5 Ch.2 Sec.5 A also apply.

A *Loading computer system* is a system, which unless stated otherwise is digital, by means of which it can be easily and quickly ascertained that, at specified read-out points, the still water bending moments, shear forces, and the still water torsional moments and lateral loads, where applicable, in any load or ballast condition will not exceed the specified permissible values.

Guidance note:

The term “Loading computer system” covers the term “Loading instrument” as commonly used in IACS UR S1.

---e-n-d---of---G-u-i-d-a-n-c-e---n-o-t-e---

An operation manual is always to be provided for the loading instrument. Single point loading instruments are not acceptable.

Category I ships. Ships with large deck openings where combined stresses due to vertical and horizontal hull girder bending and torsional and lateral loads have to be considered.

Ships liable to carry non-homogeneous loadings, where the cargo and or ballast may be unevenly distributed. Ships less than 120 m in length, when their design takes into account uneven distribution of cargo or ballast, belong to Category II.

Chemical tankers and gas carriers.

Category II Ships. Ships with arrangement giving small possibilities for variation in the distribution of cargo and ballast, and ships on regular and fixed trading pattern where the Loading Manual gives sufficient guidance, and in addition the exception given under Category I.

B. Still Water and Wave Induced Hull Girder Bending Moments and Shear Forces

B 100 Stillwater conditions

101 The design stillwater bending moments, M_S , and stillwater shear forces, Q_S , shall be calculated along the ship length for design cargo and ballast loading conditions as specified in 102.

For these calculations, downward loads are assumed to be taken as positive values, and shall be integrated in the forward direction from the aft end of L. The sign conventions of Q_S and M_S are as shown in Fig.1.

(IACS UR S11.2.1.1 Rev.7)

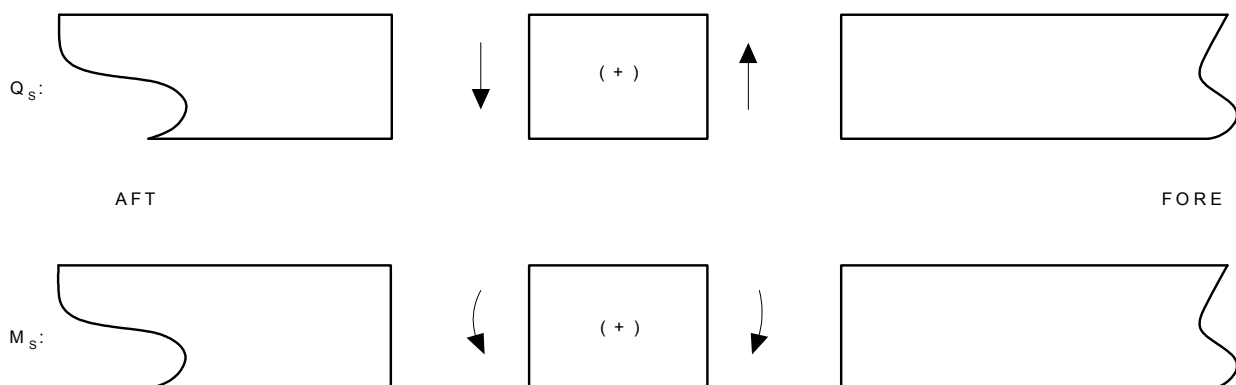

Fig. 1
Sign Conventions of Q_S and M_S

102 In general, the following design cargo and ballast loading conditions, based on amount of bunker, fresh water and stores at departure and arrival, shall be considered for the M_S and Q_S calculations. Where the amount and disposition of consumables at any intermediate stage of the voyage are considered more severe, calculations for such intermediate conditions shall be submitted in addition to those for departure and arrival conditions. Also, where any ballasting and or deballasting is intended during voyage, calculations of the

intermediate condition just before and just after ballasting and or deballasting any ballast tank shall be submitted and where approved included in the loading manual for guidance.

Cargo ships, container carriers, roll-on/roll-off and refrigerated carriers, ore carriers and bulk carriers:

- homogenous loading conditions at maximum draught
- ballast conditions
- special loading conditions, e.g. container or light load conditions at less than the maximum draught, heavy cargo, empty holds or non-homogenous cargo conditions, deck cargo conditions, etc. where applicable
- docking condition afloat
- for vessels with **BC-A**, **BC-B**, **BC-C** or **BC-B*** notation, loading conditions as specified in Pt.5 Ch.2 Sec.5 A.

Oil tankers:

- homogenous loading conditions (excluding dry and clean ballast tanks) and ballast or part-loaded conditions
- any specified non-uniform distribution of loading
- mid-voyage conditions relating to tank cleaning or other operations where these differ significantly from the ballast conditions
- docking condition afloat
- for oil carriers complying with the requirements for the segregated ballast tanks as stipulated in Pt.5 Ch.3 Sec.3 B, the ballast conditions shall in addition to the segregated ballast condition include one or more relevant conditions with additional ballast in cargo tanks.

Chemical and product tankers:

- conditions as specified for oil tankers
- conditions for high density or segregated cargo where these are included in the approved cargo list.

Liquefied gas carriers:

- homogenous loading conditions for all approved cargoes
- ballast conditions
- cargo condition where one or more tanks are empty or partially filled or where more than one type of cargo having significantly different densities is carried
- harbour condition for which an increased vapour pressure has been approved
- docking condition afloat.

Combination carriers:

- conditions as specified for oil tankers and cargo ships.

For smaller ships the stillwater bending moments and shear forces may have to be calculated for ballast and particular non-homogeneous load conditions after special considerations.

Also short voyage or harbour conditions including loading and unloading transitory conditions shall be checked where applicable.

Guidance note:

It is advised that the ballast conditions determining the scantlings are based on the filling of ballast in as few cargo tanks as practicable, and it is important that the conditions will allow cleaning of all cargo tanks with the least possible shifting.

---e-n-d---of---G-u-i-d-a-n-c-e---n-o-t-e---

(IACS UR S11.2.1.2 Rev.7)

103 Ballast loading conditions involving partially filled peak and or other ballast tanks at departure, arrival or during intermediate conditions are not permitted to be used as design conditions unless:

- design stress limits are satisfied for all filling levels between empty and full and
- for bulk carriers, Pt.5 Ch.2 Sec.8 C, as applicable, is complied with for all filling levels between empty and full.

To demonstrate compliance with all filling levels between empty and full, it will be acceptable if, in each condition at departure, arrival and where required by 102 any intermediate condition, the tanks intended to be partially filled are assumed to be:

- empty
- full
- partially filled at intended level.

Where multiple tanks are intended to be partially filled, all combinations of empty, full or partially filled at intended level for those tanks shall be investigated.

However, for conventional Ore Carriers with large wing water ballast tanks in cargo area, where empty or full ballast water filling levels of one or maximum two pairs of these tanks lead to the ship's trim exceeding one of the following conditions, it is sufficient to demonstrate compliance with maximum, minimum and intended partial filling levels of these one or maximum two pairs of ballast tanks such that the ship's condition does not exceed any of these trim limits. Filling levels of all other wing ballast tanks shall be considered between empty and full. The trim conditions mentioned above are:

- trim by stern of 3% of the ship's length, or
- trim by bow of 1.5% of ship's length, or
- any trim that cannot maintain propeller immersion (I/D) not less than 25%.

where:

I = the distance from propeller centreline to the waterline

D = propeller diameter.

See Fig.2.

The maximum and minimum filling levels of the above mentioned pairs of side ballast tanks shall be indicated in the loading manual.

(IACS UR S11.2.1.3 Rev.7)

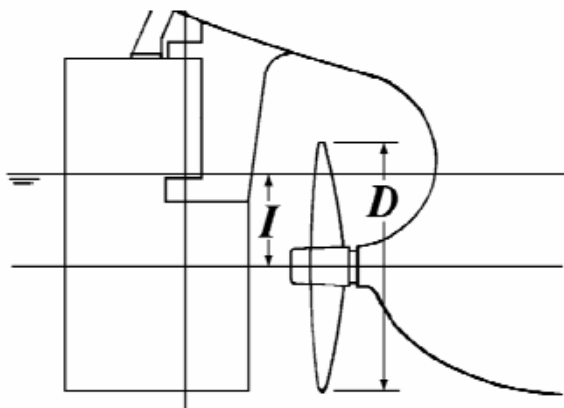

Fig. 2

104 In cargo loading conditions, the requirements given in 103 applies to peak tanks only.

(IACS UR S11.2.1.4 Rev.7)

105 Requirements given in 103 and 104 are not applicable to ballast water exchange using the sequential method. However, bending moment and shear force calculations for each de-ballasting or ballasting stage in the ballast water exchange sequence are to be included in the loading manual or ballast water management plan of any vessel that intends to employ the sequential ballast water exchange method.

(IACS UR S11.2.1.5 Rev.7)

106 The design stillwater bending moments amidships (sagging and hogging) are normally not to be taken less than:

$$M_S = M_{SO} \text{ (kNm)}$$

$$M_{SO} = -0.065 C_{WU} L^2 B (C_B + 0.7) \text{ (kNm) in sagging}$$

$$= C_{WU} L^2 B (0.1225 - 0.015 C_B) \text{ (kNm) in hogging}$$

$C_{WU} = C_W$ for unrestricted service.

Larger values of M_{SO} based on cargo and ballast conditions shall be applied when relevant, see 102.

For ships with arrangement giving small possibilities for variation of the distribution of cargo and ballast, M_{SO} may be dispensed with as design basis.

107 When required in connection with stress analysis or buckling control, the stillwater bending moments at arbitrary positions along the length of the ship are normally not to be taken less than:

$$M_S = k_{sm} M_{SO} \text{ (kNm)}$$

$M_{SO} =$ as given in 106

$k_{sm} = 1.0$ within 0.4 L amidships

$= 0.15$ at 0.1 L from A.P. or F.P.

= 0.0 at A.P. and F.P.

Between specified positions k_{sm} shall be varied linearly.

Values of k_{sm} may also be obtained from Fig.3.

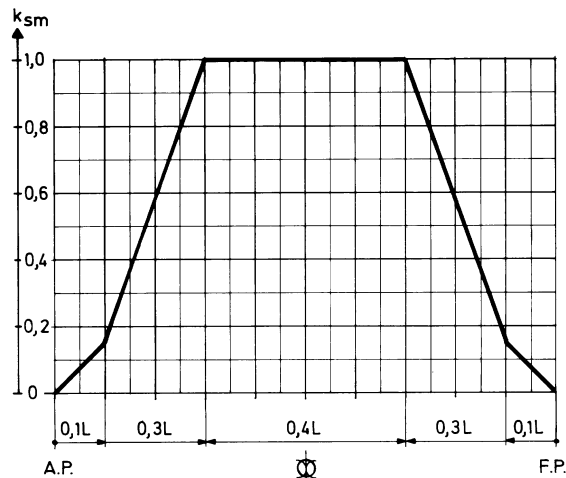

Fig. 3
Stillwater bending moment

The extent of the constant design bending moments amidships may be adjusted after special consideration.

108 The design values of stillwater shear forces along the length of the ship are normally not to be taken less than:

$$Q_S = k_{sq} Q_{SO} \quad (\text{kN})$$

$$Q_{SO} = 5 \frac{M_{SO}}{L} \quad (\text{kN})$$

M_{SO} = design stillwater bending moments (sagging or hogging) given in 106.

Larger values of Q_S based on load conditions ($Q_S = Q_{SL}$) shall be applied when relevant, see 102. For ships with arrangement giving small possibilities for variation in the distribution of cargo and ballast, Q_{SO} may be dispensed with as design basis

$k_{sq} = 0$ at A.P. and F.P.

= 1.0 between 0.15 L and 0.3 L from A.P.

= 0.8 between 0.4 L and 0.6 L from A.P.

= 1.0 between 0.7 L and 0.85 L from A.P.

Between specified positions k_{sq} shall be varied linearly.

Sign convention to be applied:

- when sagging condition positive in forebody, negative in afterbody
- when hogging condition negative in forebody, positive in afterbody.

B 200 Wave load conditions

201 The rule vertical wave bending moments amidships are given by:

$$M_W = M_{WO} \quad (\text{kNm})$$

$M_{WO} = -0.11 \alpha C_W L^2 B (C_B + 0.7)$ (kNm) in sagging

= $0.19 \alpha C_W L^2 B C_B$ (kNm) in hogging

$\alpha = 1.0$ for seagoing conditions

= 0.5 for harbour and sheltered water conditions (enclosed fjords, lakes, rivers).

C_B is not be taken less than 0.6.

202 When required in connection with stress analysis or buckling control, the wave bending moments at arbitrary positions along the length of the ship are normally not to be taken less than:

$$M_W = k_{wm} M_{WO} \quad (\text{kNm})$$

$M_{WO} =$ as given in 201

$k_{wm} = 1.0$ between 0.40 L and 0.65 L from A.P.
 $= 0.0$ at A.P. and F.P.

For ships with high speed and/or large flare in the forebody the adjustments to k_{wm} as given in Table B1, limited to the control for buckling as given in Sec.13, apply.

Table B1 Adjustments to k_{wm}				
Load condition	Sagging and hogging		Sagging only	
C_{AV}	≤ 0.28	≥ 0.32 ¹⁾		
C_{AF}			≤ 0.40	≥ 0.50
k_{wm}	No adjustment	1.2 between 0.48 L and 0.65 L from A.P. 0.0 at F.P. and A.P.	No adjustment	1.2 between 0.48 L and 0.65 L from A.P. 0.0 at F.P. and A.P.

1) Adjustment for C_{AV} not to be applied when $C_{AF} \geq 0.50$.

$$C_{AV} = \frac{c_v V}{\sqrt{L}}$$

$$C_{AF} = \frac{c_v V}{\sqrt{L}} + \frac{A_{DK} - A_{WP}}{L z_f}$$

$$c_v = \frac{\sqrt{L}}{50}, \text{ maximum } 0.2$$

A_{DK} = projected area in the horizontal plane of upper deck (including any forecastle deck) forward of 0.2 L from F.P.

A_{WP} = area of waterplane forward of 0.2 L from F.P. at draught T

z_f = vertical distance from summer load waterline to deckline measured at F.P.

Between specified C_A -values and positions k_{wm} shall be varied linearly. Values of k_{wm} may also be obtained from Fig.4.

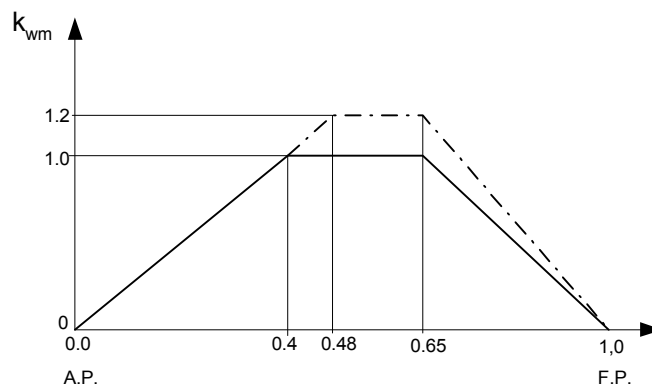

Fig. 4
Wave bending moment distribution

203 The rule values of vertical wave shear forces along the length of the ship are given by:

Positive shear force, to be used when positive still water shear force:

$$Q_{WP} = 0.3 \beta k_{wqp} C_W L B (C_B + 0.7) \text{ (kN)}$$

Negative shear force, to be used when negative still water shear force:

$$Q_{WN} = -0.3 \beta k_{wqn} C_W L B (C_B + 0.7) \text{ (kN)}$$

Positive shear force when there is a surplus of buoyancy forward of section considered, see also Fig.1.

Negative shear force when there is a surplus of weight forward of section considered.

$\beta = 1.0$ for seagoing conditions

$= 0.5$ for harbour and sheltered water conditions (enclosed fjords, lakes, rivers)

$k_{wqp} = 0$ at A.P. and F.P.

- = $1.59 C_B / (C_B + 0.7)$ between 0.2 L and 0.3 L from A.P.
- = 0.7 between 0.4 L and 0.6 L from A.P.
- = 1.0 between 0.7 L and 0.85 L from A.P.
- k_{wqn} = 0 at A.P. and F.P.
- = 0.92 between 0.2 L and 0.3 L from A.P.
- = 0.7 between 0.4 L and 0.6 L from A.P.
- = $1.73 C_B / (C_B + 0.7)$ between 0.7 L and 0.85 L from A.P.
- C_W = as given in 201.

For ships with high speed and or large flare in the forebody, the adjustments given in Table B2 apply.

Table B2 Adjustments to k_{wq}				
Load condition	Sagging and hogging			Sagging only
C_{AV}	≤ 0.28	≥ 0.32 ¹⁾		
C_{AF}			≤ 0.40	≥ 0.50
Multiply k_{wq} by	1.0	1.0 aft of 0.6 L from A.P. 1.2 between 0.7 L and 0.85 L from A.P.		1.0 1.0 aft of 0.6 L from A.P. 1.2 between 0.7 L and 0.85 L from A.P.

1) Adjustment for C_{AV} not to be applied when $C_{AF} \geq 0.50$.

C_{AV} = as defined in 202

C_{AF} = as defined in 202.

Between specified positions k_{wq} shall be varied linearly. Values of k_{wq} may also be obtained from Fig.5.

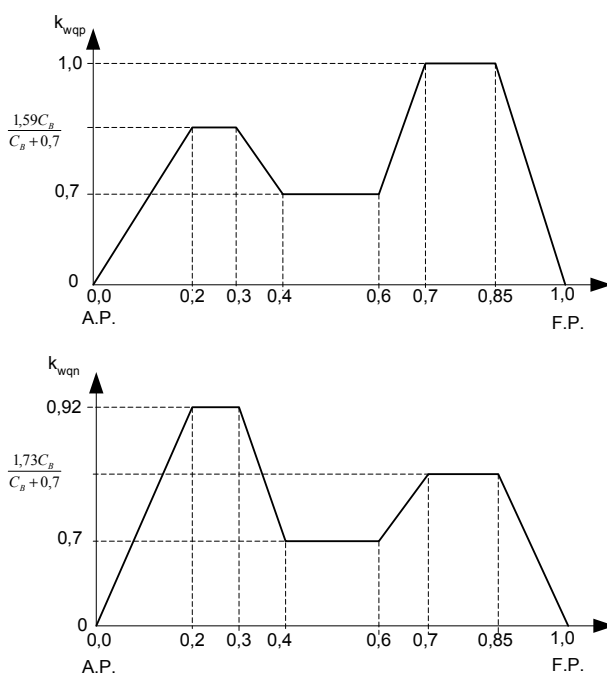

Fig. 5
Wave shear force distribution

204 When hull girder stresses due to wave loads are combined with local stresses in girder systems, stiffeners and plating in accordance with Sec.12, the wave bending moments and shear forces may be reduced as follows:

$$M_{WR} = 0.59 M_W$$

$$Q_{WR} = 0.59 Q_W$$

205 The rule horizontal wave bending moments along the length of the ship are given by:

$$M_{WH} = 0.22 L^{9/4} (T + 0.3 B) C_B (1 - \cos (360 x/L)) \text{ (kNm)}$$

x = distance in m from A.P. to section considered.

206 The rule wave torsional moments along the length of the ship due to the horizontal wave- and inertia forces and the rotational wave- and inertia moment loads are given by:

$$M_{WT} = K_{T1} L^{5/4} (T + 0.3 B) C_B z_e$$

$$\pm K_{T2} L^{4/3} B^2 C_{SWP} \quad (\text{kNm})$$

$$K_{T1} = 1.40 \sin(360 x/L)$$

$$K_{T2} = 0.13 (1 - \cos(360 x/L))$$

$$C_{SWP} = A_{WP}/(LB)$$

A_{WP} = water plane area of vessel in m^2 at draught T

z_e = distance in m from the shear centre of the midship section to a level 0.7 T above the base line

x = distance in m from A.P. to section considered.

C. Bending Strength and Stiffness

C 100 Midship section particulars

101 When calculating the moment of inertia and section modulus, the effective sectional area of continuous longitudinal strength members is in general the net area after deduction for openings as given in E.

The effective sectional area of strength members between hatch openings in ships with twin or triple hatchways shall be taken as the net area multiplied by a factor 0.6 unless a higher factor is justified by direct calculations.

Superstructures which do not form a strength deck shall not be included in the net section. This applies also to deckhouses, bulwarks and non-continuous hatch side coamings.

For definition of strength deck, see Sec.1 B205.

102 The rule section modulus generally refers to the baseline and the deckline.

103 Continuous trunks, longitudinal hatch coamings and above deck longitudinal girders shall be included in the longitudinal sectional area provided they are effectively supported by longitudinal bulkheads or deep girders. The deck modulus is then to be calculated by dividing the moment of inertia by the following distance, provided this is greater than the distance to the deck line at side:

$$z = (z_n + z_a) \left[0.9 + 0.2 \frac{y_a}{B} \right], \quad \text{minimum } z_n$$

y_a = distance in m from the centre line of the ship to the side of the strength member.

y_a and z_a shall be measured to the point giving the largest value of z .

104 The main strength members included in the hull section modulus calculation shall extend continuously through the cargo region and sufficiently far towards the ends of the ship.

105 Longitudinal bulkheads shall terminate at an effective transverse bulkhead, and large transition brackets shall be fitted in line with the longitudinal bulkheads.

C 200 Extent of high strength steel (HS-steel)

201 The vertical extent of HS-steel used in deck or bottom shall not be less than:

$$z_{hs} = z_n \frac{f_2 - f_3}{f_2}$$

f_2 = stress factor, for the bottom given in Sec.6 and for the deck in Sec.8

f_3 = material factor (general symbol f_1) for the members located more than z_{hs} from deck or bottom, see Fig.6.

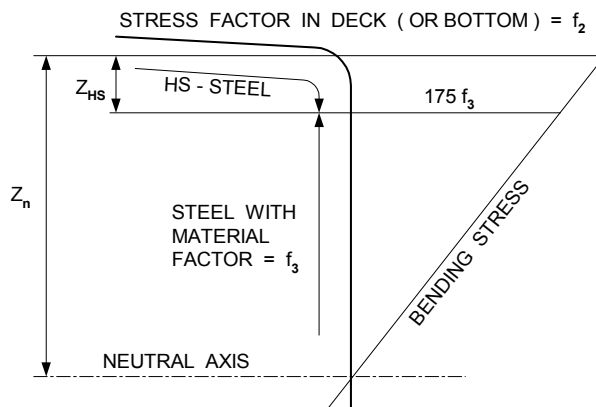

Fig. 6
Vertical extent of HS-steel

For narrow beam ships the vertical extent of HS-steel may have to be increased after special consideration.

202 The longitudinal extent of HS-steel used in deck or bottom shall not be less than x_{HS} as indicated in Fig. 7.

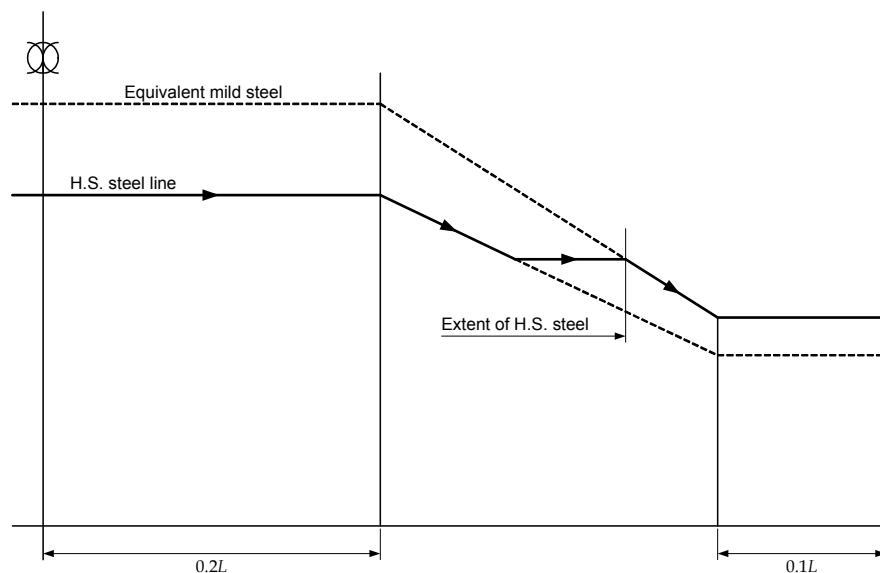

Fig. 7
Longitudinal extent of HS-steel

x_{HS} (minimum) implies that the midship scantlings shall be maintained outside $0.4 L$ amidships to a point where the scantlings equal those of an identical ship built of normal strength steel over the full length. x_{HS} (general) implies that the scantlings outside $0.4 L$ may be gradually reduced as if HS-steel was used over the full length. Where material strength group changes, however, continuity in scantlings shall be maintained.

C 300 Section modulus

301 The requirements given in 302 and 303 will normally be satisfied when calculated for the midship section only, provided the following rules for tapering are complied with:

- Scantlings of all continuous longitudinal strength members shall be maintained within $0.4 L$ amidships.
In special cases, based on consideration of type of ship, hull form and loading conditions, the scantlings may be gradually reduced towards the ends of the $0.4 L$ amidship part, bearing in mind the desire not to inhibit the vessel's loading flexibility.
- Scantlings outside $0.4 L$ amidships are gradually reduced to the local requirements at the ends, and the same material strength group is applied over the full length of the ship.

The section modulus at other positions along the length of the ship may have to be specially considered for ships with small block coefficient, high speed and large flare in the forebody or when considered necessary due to structural arrangement, see A106.

In particular this applies to ships of length $L > 120$ m and speed $V > 17$ knots.

302 As a minimum, hull girder bending strength checks are to be carried out at the following locations:

- In way of the forward end of the engine room.
- In way of the forward end of the foremost cargo hold.
- At any locations where there are significant changes in hull cross-section.
- At any locations where there are changes in the framing system.

Buckling strength of members contributing to the longitudinal strength and subjected to compressive and shear stresses is to be checked, in particular in regions where changes in the framing system or significant changes in the hull cross-section occur. The buckling evaluation criteria used for this check is determined by each Classification Society.

Continuity of structure is to be maintained throughout the length of the ship. Where significant changes in structural arrangement occur adequate transitional structure is to be provided.

For ships with large deck openings such as container ships, sections at or near to the aft and forward quarter length positions are to be checked. For such ships with cargo holds aft of the superstructure, deckhouse or engine room, strength checks of sections in way of the aft end of the aft-most holds, and the aft end of the deckhouse or engine room are to be performed.

303 The midship section modulus about the transverse neutral axis shall not be less than:

$$Z_O = \frac{C_{WO}}{f_1} L^2 B (C_B + 0.7) \quad (\text{cm}^3)$$

$$\begin{aligned} C_{WO} &= 10.75 - [(300 - L)/100]^{3/2} \quad \text{for } L < 300 \\ &= 10.75 \quad \text{for } 300 \leq L \leq 350 \\ &= 10.75 - [(L - 350)/150]^{3/2} \quad \text{for } L > 350 \end{aligned}$$

Values of C_{WO} are also given in Table C1.

C_B is in this case not to be taken less than 0.60.

L	C_{WO}	L	C_{WO}	L	C_{WO}
		160	9.09	260	10.50
		170	9.27	280	10.66
		180	9.44	300	10.75
		190	9.60	350	10.75
100	7.92	200	9.75	370	10.70
110	8.14	210	9.90	390	10.61
120	8.34	220	10.03	410	10.50
130	8.53	230	10.16	440	10.29
140	8.73	240	10.29	470	10.03
150	8.91	250	10.40	500	9.75

For ships with restricted service, C_{WO} may be reduced as follows:

- service area notation **R0**: No reduction
- service area notation **R1**: 5%
- service area notation **R2**: 10%
- service area notation **R3**: 15%
- service area notation **R4**: 20%
- service area notation **RE**: 25%.

304 The section modulus requirements about the transverse neutral axis based on cargo and ballast conditions are given by:

$$Z_O = \frac{|M_S + M_W|}{\sigma_l} 10^3 \quad (\text{cm}^3)$$

$$\begin{aligned} \sigma_l &= 175 f_1 \text{ N/mm}^2 \text{ within } 0.4 L \text{ amidship} \\ &= 125 f_1 \text{ N/mm}^2 \text{ within } 0.1 L \text{ from A.P. or F.P.} \end{aligned}$$

Between specified positions σ_l shall be varied linearly.

ANEXO III

Report Resistencia Longitudinal

Longitudinal Strength Calculation

Model file: C:\Users\Usuario\Desktop\TFG\CUADERNO 5\ANALIZADO DEFINITIVO (Medium precision, 65 sections, Trimming off, Skin thickness not applied).
 Long. datum: AP; Vert. datum: Baseline. Analysis tolerance - ideal(worst case): Disp.%; 0,01000(0,100); Trim%(LCG-TCG): 0,01000(0,100); Heel%(LCG-TCG): 0,01000(0,100)

Loadcase - C1 Salida puerto a plena carga

Damage Case - Intact

Free to Trim

Specific gravity = 1,025; (Density = 1,025 tonne/m³)

Fluid analysis method: Simulate fluid movement

Item Name	Quantity	Unit Mass tonne	Total Mass tonne	Unit Volume m ³	Total Volume m ³	Long. Arm m	Aft. Limit m	Fwd. Limit m	Trans. Arm m	Vert. Arm m
rosca	1	36099,280	36099,280			116,086			0,000	13,421
Total rosca			36099,280			116,086			0,000	13,421
Tanque 4	97%	17383,695	16862,185	40427,198	39214,382	78,073			0,000	15,621
Tanque 3	97%	18236,208	17689,121	42409,786	41137,491	126,333			0,000	15,074
Tanque 2	97%	18216,099	17669,618	42363,021	41092,134	175,335			0,000	15,077
Tanque 1	97%	10179,370	9873,988	23672,952	22962,763	218,232			0,000	15,727
Total carga	97%	64015,373	62094,912	148872,958	144406,770	141,785			0,000	15,327
Pique PP BR	0%	2703,969	0,000	2638,019	0,000	10,447			-8,032	11,850
Pique PP ER	0%	2704,001	0,000	2638,050	0,000	10,447			8,032	11,850
Cofferdam 5	0%	2150,709	0,000	2098,253	0,000	54,119			0,000	6,423
Cofferdam 4	0%	2608,203	0,000	2544,588	0,000	103,144			0,000	2,500
Cofferdam 3	0%	2608,196	0,000	2544,581	0,000	152,169			0,000	2,500
Cofferdam 2	0%	2512,692	0,000	2451,407	0,000	201,194			0,000	2,500
Cofferdam 1	0%	717,353	0,000	699,857	0,000	241,926			0,000	6,329
Pique PR BR	0%	411,594	0,000	401,555	0,000	273,158			-0,180	2,500
Pique PR ER	0%	411,594	0,000	401,555	0,000	273,158			0,180	2,500
Lastre 4 BR	0%	4509,134	0,000	4399,155	0,000	100,107			-0,007	0,000
Lastre 4 ER	0%	4509,134	0,000	4399,155	0,000	100,107			0,007	0,000
Lastre 3 BR	0%	5368,684	0,000	5237,740	0,000	149,132			-0,011	0,000
Lastre 3 ER	0%	5368,684	0,000	5237,740	0,000	149,132			0,011	0,000
Lastre 2 BR	0%	4765,443	0,000	4649,212	0,000	198,157			-0,010	0,000
Lastre 2 ER	0%	4765,443	0,000	4649,212	0,000	198,157			0,010	0,000
Lastre 1 BR	0%	4575,151	0,000	4463,562	0,000	244,422			-0,001	0,000
Lastre 1 ER	0%	4575,151	0,000	4463,562	0,000	244,422			0,001	0,000
Total lastre	0%	55265,135	0,000	53917,205	0,000	0,000			0,000	0,000
Agua dulce BR	100%	76,795	76,795	76,795	76,795	8,655			-1,352	23,595
Agua dulce ER	100%	76,795	76,795	76,795	76,795	8,655			1,352	23,595
Aceite BR	100%	49,417	49,417	54,908	54,908	32,095			-17,140	22,900

Aceite ER	100%	49,417	49,417	54,908	54,908	32,095			17,140	22,900
FO UD BR	100%	92,783	92,783	95,653	95,653	36,305			-16,790	22,490
FO UD ER	100%	92,783	92,783	95,653	95,653	36,305			16,790	22,490
FO Sed. BR	100%	139,540	139,540	143,855	143,855	41,235			-16,440	22,140
FO Sed. ER	100%	139,540	139,540	143,855	143,855	41,235			16,440	22,140
Diesel BR	100%	382,873	382,873	425,414	425,414	47,627			-15,230	21,045
Diesel ER	100%	382,873	382,873	425,414	425,414	47,627			15,230	21,045
Aguas grises	0%	238,468	0,000	158,979	0,000	51,354			0,000	0,000
Lodos	0%	113,158	0,000	75,439	0,000	43,288			0,000	0,000
FO Almacén	100%	2322,658	2322,658	2394,493	2394,493	251,161			-4,284	15,197
FO Almacén	100%	2322,658	2322,658	2394,493	2394,493	251,161			4,284	15,197
Viveres	1	4,375	4,375			57,000	57,000	57,000	0,000	39,200
Total consumos			6132,507			199,949			0,000	16,816
Tripulacion	1	5,250	5,250			57,000	57,000	57,000	0,000	39,200
Perterechos	1	100,000	100,000			128,000	128,000	128,000	0,000	28,000
Total pesos fijos			105,250			124,458			0,000	28,559
Total Loadcase			104431,949	209406,816	150789,006	136,300			0,000	14,769

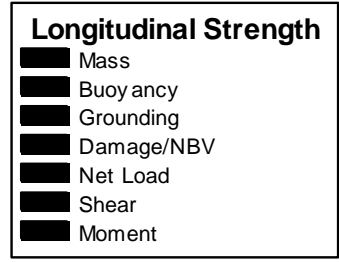
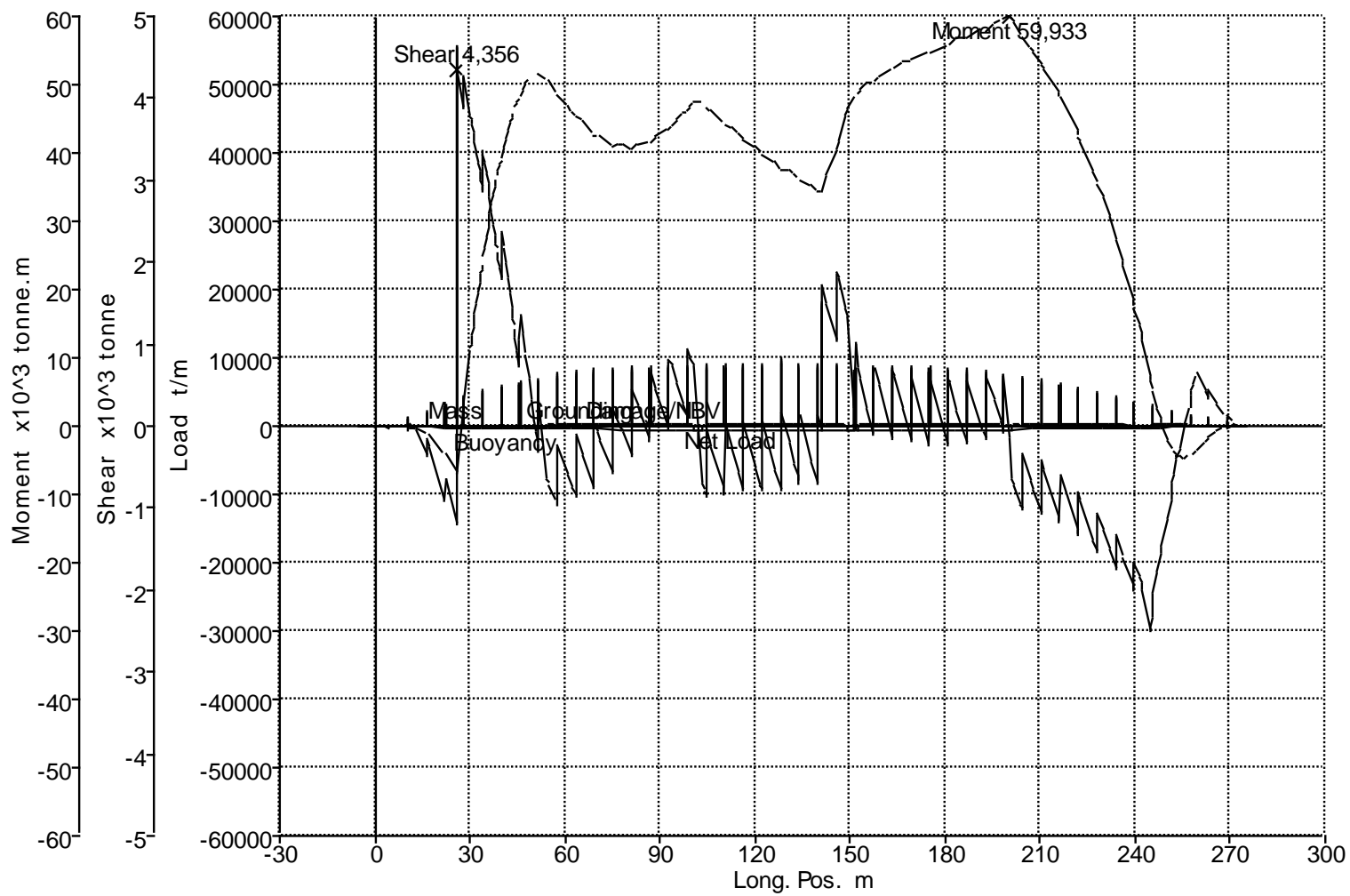

Name	Long. Pos.	Mass t/m	Buoyancy	Grounding	Damage/NBV	Net Load	Shear x10 ³	Moment x10 ³
------	------------	----------	----------	-----------	------------	----------	------------------------	-------------------------

	m		t/m	t/m	t/m	t/m	tonne	tonne.m
-1/4	-5,304	0,000	0,000	0,000	0,000	0,000	0,000	0,000
0	-1,933	0,000	0,000	0,000	0,000	0,000	0,000	0,001
1/2	4,810	0,000	-15,777	0,000	0,000	-15,777	-0,024	-0,028
1	11,552	0,000	-60,262	0,000	0,000	-60,262	0,022	-0,164
1 1/2	18,295	0,000	-119,356	0,000	0,000	-119,356	-0,383	-1,658
2	25,037	0,000	-188,090	0,000	0,000	-188,090	-1,095	-6,478
2 1/2	31,780	26,008	-269,059	0,000	0,000	-243,050	3,415	17,015
3	38,522	40,166	-326,264	0,000	0,000	-286,098	2,156	36,570
4	52,007	0,000	-401,773	0,000	0,000	-401,773	0,219	51,389
5	65,492	337,036	-452,348	0,000	0,000	-115,312	-0,341	44,688
6	78,977	383,209	-483,700	0,000	0,000	-100,491	-0,158	41,044
7	92,462	384,587	-503,163	0,000	0,000	-118,575	0,012	43,275
8	105,947	380,338	-516,895	0,000	0,000	-136,556	-0,216	46,337
9	119,432	381,763	-526,531	0,000	0,000	-144,768	-0,398	41,069
10	132,917	383,166	-532,550	0,000	0,000	-149,384	-0,558	36,591
11	146,402	384,545	-535,042	0,000	0,000	-150,497	1,775	42,025
12	159,887	380,866	-533,891	0,000	0,000	-153,025	0,355	51,519
13	173,372	382,282	-528,533	0,000	0,000	-146,251	0,011	54,373
14	186,857	383,676	-513,268	0,000	0,000	-129,592	0,560	56,755
15	200,342	0,000	-483,249	0,000	0,000	-483,249	-0,227	59,877
16	213,827	287,352	-418,289	0,000	0,000	-130,937	-0,878	50,169
17	227,312	212,077	-332,900	0,000	0,000	-120,822	-1,466	36,352
17 1/2	234,055	171,758	-287,395	0,000	0,000	-115,637	-1,364	26,807
18	240,797	123,006	-234,325	0,000	0,000	-111,319	-1,796	15,370
18 1/2	247,540	385,294	-178,190	0,000	0,000	207,104	-1,624	1,473
19	254,282	280,700	-124,189	0,000	0,000	156,511	-0,195	-4,557
19 1/2	261,025	0,000	-84,823	0,000	0,000	-84,823	0,500	-2,561
20	267,767	0,000	-56,111	0,000	0,000	-56,111	0,123	-0,347
20 1/4	271,138	0,000	-29,051	0,000	0,000	-29,051	0,045	-0,058
20 1/2	274,510	0,000	-4,732	0,000	0,000	-4,732	0,003	-0,003

Longitudinal Strength Calculation

Stability 20.00.04.9, build: 9

Model file: C:\Users\Usuario\Desktop\TFG\CUADERNO 5\ANALIZADO DEFINITIVO (Medium precision, 65 sections, Trimming off, Skin thickness not applied).

Long. datum: AP; Vert. datum: Baseline. Analysis tolerance - ideal(worst case): Disp.‰: 0,01000(0,100); Trim‰(LCG-TCG): 0,01000(0,100); Heel‰(LCG-TCG): 0,01000(0,100)

Loadcase - C2 Salida de puerto en lastre

Damage Case - Intact

Free to Trim

Specific gravity = 1,025; (Density = 1,025 tonne/m³)

Fluid analysis method: Simulate fluid movement

Item Name	Quantity	Unit Mass tonne	Total Mass tonne	Unit Volume m ³	Total Volume m ³	Long. Arm m	Aft. Limit m	Fwd. Limit m	Trans. Arm m	Vert. Arm m
rosca	1	36099,280	36099,280			116,086			0,000	13,421
Total rosca			36099,280			116,086			0,000	13,421
Tanque 4	0%	17383,695	0,000	40427,198	0,000	77,260			0,000	2,500
Tanque 3	0%	18236,208	0,000	42409,786	0,000	103,423			0,000	2,500
Tanque 2	0%	18216,099	0,000	42363,021	0,000	152,448			0,000	2,500
Tanque 1	0%	10179,370	0,000	23672,952	0,000	201,441			0,000	2,500
Total carga	0%	64015,373	0,000	148872,958	0,000	0,000			0,000	0,000
Pique PP BR	100%	2703,969	2703,969	2638,019	2638,019	3,809			-8,973	19,875
Pique PP ER	100%	2704,001	2704,001	2638,050	2638,050	3,809			8,973	19,875
Cofferdam 5	100%	2150,709	2150,709	2098,253	2098,253	52,770			0,000	17,477
Cofferdam 4	100%	2608,203	2608,203	2544,588	2544,588	101,772			0,000	15,460
Cofferdam 3	100%	2608,196	2608,196	2544,581	2544,581	150,798			0,000	15,460
Cofferdam 2	100%	2512,692	2512,692	2451,407	2451,407	199,813			0,000	15,509
Cofferdam 1	100%	717,353	717,353	699,857	699,857	243,256			0,000	17,484
Pique PR BR	100%	411,594	411,594	401,555	401,555	268,098			-1,679	15,907
Pique PR ER	100%	411,594	411,594	401,555	401,555	268,098			1,679	15,907
Lastre 4 BR	100%	4509,134	4509,134	4399,155	4399,155	77,576			-15,302	9,501
Lastre 4 ER	100%	4509,134	4509,134	4399,155	4399,155	77,576			15,302	9,501
Lastre 3 BR	100%	5368,684	5368,684	5237,740	5237,740	124,977			-15,690	8,340
Lastre 3 ER	100%	5368,684	5368,684	5237,740	5237,740	124,977			15,690	8,340
Lastre 2 BR	100%	4765,443	4765,443	4649,212	4649,212	172,522			-15,153	8,809
Lastre 2 ER	100%	4765,443	4765,443	4649,212	4649,212	172,522			15,153	8,809
Lastre 1 BR	100%	4575,151	4575,151	4463,562	4463,562	222,028			-13,012	14,284
Lastre 1 ER	100%	4575,151	4575,151	4463,562	4463,562	222,028			13,012	14,284
Total lastre	100%	55265,135	55265,135	53917,205	53917,205	134,036			0,000	12,308
Agua dulce BR	100%	76,795	76,795	76,795	76,795	8,655			-1,352	23,595
Agua dulce ER	100%	76,795	76,795	76,795	76,795	8,655			1,352	23,595
Aceite BR	100%	49,417	49,417	54,908	54,908	32,095			-17,140	22,900
Aceite ER	100%	49,417	49,417	54,908	54,908	32,095			17,140	22,900

FO UD BR	100%	92,783	92,783	95,653	95,653	36,305			-16,790	22,490
FO UD ER	100%	92,783	92,783	95,653	95,653	36,305			16,790	22,490
FO Sed. BR	100%	139,540	139,540	143,855	143,855	41,235			-16,440	22,140
FO Sed. ER	100%	139,540	139,540	143,855	143,855	41,235			16,440	22,140
Diesel BR	100%	382,873	382,873	425,414	425,414	47,627			-15,230	21,045
Diesel ER	100%	382,873	382,873	425,414	425,414	47,627			15,230	21,045
Aguas grises	0%	238,468	0,000	158,979	0,000	43,366			0,000	0,000
Lodos	0%	113,158	0,000	75,439	0,000	37,652			0,000	0,000
FO Almacén	100%	2322,658	2322,658	2394,493	2394,493	251,161			-4,284	15,197
FO Almacén	100%	2322,658	2322,658	2394,493	2394,493	251,161			4,284	15,197
Viveres	1	4,375	4,375			57,000	57,000	57,000	0,000	39,200
Total consumos			6132,507			199,949			0,000	16,816
Tripulacion	1	5,250	5,250			57,000	57,000	57,000	0,000	39,200
Perterechos	1	100,000	100,000			128,000	128,000	128,000	0,000	28,000
Total pesos fijos			105,250			124,458			0,000	28,559
Total Loadcase			97602,172	209406,816	60299,441	131,528			0,000	13,021

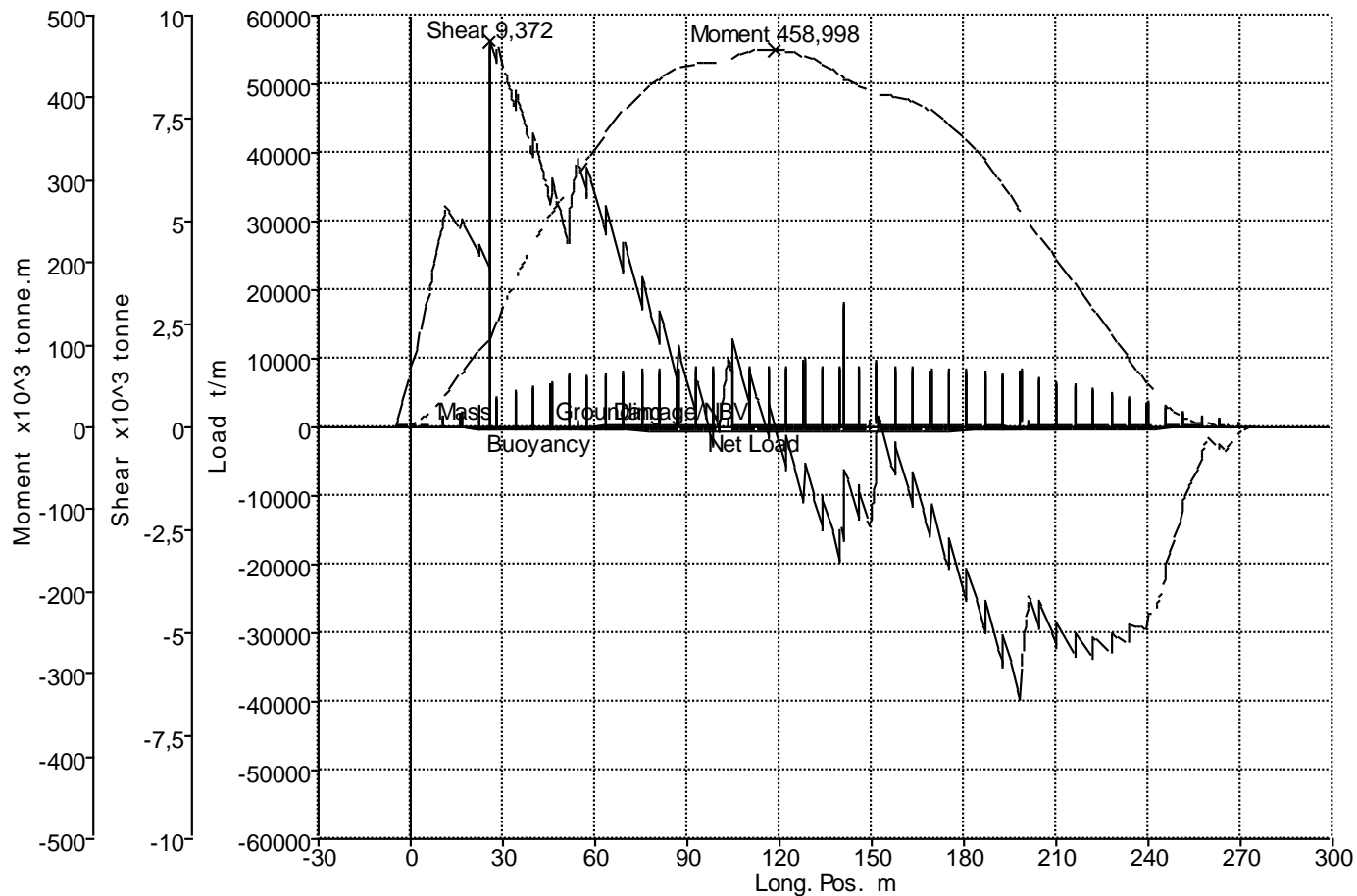

Name	Long. Pos. m	Mass t/m	Buoyancy t/m	Grounding t/m	Damage/NBV t/m	Net Load t/m	Shear x10 ³ tonne	Moment x10 ³ tonne.m
-1/4	-5,304	0,000	0,000	0,000	0,000	0,000	0,000	0,000
0	-1,933	280,725	0,000	0,000	0,000	280,724	0,826	1,380
1/2	4,810	351,290	-22,456	0,000	0,000	328,834	2,898	13,641
1	11,552	0,000	-77,189	0,000	0,000	-77,189	5,330	41,312
1 1/2	18,295	0,000	-140,851	0,000	0,000	-140,851	4,793	75,153
2	25,037	0,000	-208,845	0,000	0,000	-208,845	3,936	104,741
2 1/2	31,780	26,008	-287,230	0,000	0,000	-261,222	8,313	161,703
3	38,522	40,166	-341,837	0,000	0,000	-301,672	6,939	213,883
4	52,007	923,604	-410,211	0,000	0,000	513,394	5,401	292,314
5	65,492	169,711	-453,844	0,000	0,000	-284,133	4,815	367,324
6	78,977	193,515	-478,337	0,000	0,000	-284,822	2,575	418,018
7	92,462	207,772	-490,693	0,000	0,000	-282,921	0,403	440,971
8	105,947	216,107	-497,315	0,000	0,000	-281,208	1,748	449,966
9	119,432	220,002	-499,777	0,000	0,000	-279,775	-0,315	458,526
10	132,917	220,824	-498,676	0,000	0,000	-277,853	-2,246	443,069
11	146,402	218,578	-494,016	0,000	0,000	-275,438	-1,618	414,266
12	159,887	212,352	-485,790	0,000	0,000	-273,438	-1,010	399,995
13	173,372	201,754	-473,372	0,000	0,000	-271,619	-3,008	373,789
14	186,857	178,314	-451,961	0,000	0,000	-273,648	-4,233	323,575
15	200,342	1055,776	-417,311	0,000	0,000	638,465	-4,677	250,431
16	213,827	207,668	-352,471	0,000	0,000	-144,803	-5,256	185,859
17	227,312	218,326	-273,243	0,000	0,000	-54,917	-5,449	114,582
17 1/2	234,055	213,818	-233,111	0,000	0,000	-19,292	-4,803	79,933
18	240,797	181,330	-188,281	0,000	0,000	-6,951	-4,542	47,609
18 1/2	247,540	385,294	-142,199	0,000	0,000	243,095	-2,852	21,575
19	254,282	280,700	-99,300	0,000	0,000	181,400	-1,218	7,989
19 1/2	261,025	0,000	-71,585	0,000	0,000	-71,585	-0,395	3,563
20	267,767	128,301	-51,060	0,000	0,000	77,240	-0,283	0,581
20 1/4	271,138	53,039	-28,734	0,000	0,000	24,305	-0,052	0,084
20 1/2	274,510	7,034	-4,745	0,000	0,000	2,289	-0,002	0,002

Longitudinal Strength Calculation

Stability 20.00.04.9, build: 9

Model file: C:\Users\Usuario\Desktop\TFG\CUADERNO 5\ANALIZADO DEFINITIVO (Medium precision, 65 sections, Trimming off, Skin thickness not applied).

Long. datum: AP; Vert. datum: Baseline. Analysis tolerance - ideal(worst case): Disp. %: 0,01000(0,100); Trim%(LCG-TCG): 0,01000(0,100); Heel%(LCG-TCG): 0,01000(0,100)

Loadcase - C3 Llegada a puerto a plena carga

Damage Case - Intact

Free to Trim

Specific gravity = 1,025; (Density = 1,025 tonne/m³)

Fluid analysis method: Simulate fluid movement

Item Name	Quantity	Unit Mass tonne	Total Mass tonne	Unit Volume m ³	Total Volume m ³	Long. Arm m	Aft. Limit m	Fwd. Limit m	Trans. Arm m	Vert. Arm m
rosca	1	36099,280	36099,280			116,086			0,000	13,421
Total rosca			36099,280			116,086			0,000	13,421
Tanque 4	97%	17383,695	16862,185	40427,198	39214,384	78,005			0,000	15,621
Tanque 3	97%	18236,208	17689,124	42409,786	41137,497	126,268			0,000	15,074
Tanque 2	97%	18216,099	17669,619	42363,021	41092,136	175,270			0,000	15,077
Tanque 1	97%	10179,370	9873,989	23672,952	22962,765	218,181			0,000	15,726
Total carga	97%	64015,373	62094,918	148872,958	144406,783	141,721			0,000	15,327
Pique PP BR	0%	2703,969	0,000	2638,019	0,000	5,151			-4,293	11,850
Pique PP ER	0%	2704,001	0,000	2638,050	0,000	5,151			4,293	11,850
Cofferdam 5	0%	2150,709	0,000	2098,253	0,000	54,119			0,000	6,423
Cofferdam 4	0%	2608,203	0,000	2544,588	0,000	100,401			0,000	2,500
Cofferdam 3	0%	2608,196	0,000	2544,581	0,000	149,426			0,000	2,500
Cofferdam 2	0%	2512,692	0,000	2451,407	0,000	198,451			0,000	2,500
Cofferdam 1	0%	717,353	0,000	699,857	0,000	241,926			0,000	6,329
Pique PR BR	0%	411,594	0,000	401,555	0,000	265,218			-0,929	2,500
Pique PR ER	0%	411,594	0,000	401,555	0,000	265,218			0,929	2,500
Lastre 4 BR	0%	4509,134	0,000	4399,155	0,000	51,678			-0,001	0,000
Lastre 4 ER	0%	4509,134	0,000	4399,155	0,000	51,678			0,001	0,000
Lastre 3 BR	0%	5368,684	0,000	5237,740	0,000	100,663			-0,007	0,000
Lastre 3 ER	0%	5368,684	0,000	5237,740	0,000	100,663			0,007	0,000
Lastre 2 BR	0%	4765,443	0,000	4649,212	0,000	149,688			-0,011	0,000
Lastre 2 ER	0%	4765,443	0,000	4649,212	0,000	149,688			0,011	0,000
Lastre 1 BR	0%	4575,151	0,000	4463,562	0,000	198,698			-0,010	0,000
Lastre 1 ER	0%	4575,151	0,000	4463,562	0,000	198,698			0,010	0,000
Total lastre	0%	55265,135	0,000	53917,205	0,000	0,000			0,000	0,000
Agua dulce BR	5%	76,795	3,840	76,795	3,840	8,627			-1,352	21,025
Agua dulce ER	5%	76,795	3,840	76,795	3,840	8,627			1,352	21,025

Aceite BR	5%	49,417	2,471	54,908	2,745	32,075			-17,140	21,095
Aceite ER	5%	49,417	2,471	54,908	2,745	32,075			17,140	21,095
FO UD BR	100%	92,783	92,783	95,653	95,653	36,305			-16,790	22,490
FO UD ER	100%	92,783	92,783	95,653	95,653	36,305			16,790	22,490
FO Sed. BR	91,87%	139,540	128,195	143,855	132,160	41,234			-16,440	21,924
FO Sed. ER	91,87%	139,540	128,195	143,855	132,160	41,234			16,440	21,924
Diesel BR	5%	382,873	19,144	425,414	21,271	47,588			-15,230	17,478
Diesel ER	5%	382,873	19,144	425,414	21,271	47,588			15,230	17,478
Aguas grises	100%	238,468	238,468	158,979	158,979	47,383			0,000	1,318
Lodos	100%	113,158	113,158	75,439	75,439	40,477			0,000	1,302
FO Almacén	0%	2322,658	0,000	2394,493	0,000	244,768			-3,122	2,500
FO Almacén	0%	2322,658	0,000	2394,493	0,000	244,768			3,122	2,500
Viveres	1	0,438	0,438			57,000	57,000	57,000	0,000	39,200
Total consumos			844,929			41,732			0,000	13,265
Tripulacion	1	5,250	5,250			57,000	57,000	57,000	0,000	39,200
Perterechos	1	100,000	100,000			128,000	128,000	128,000	0,000	28,000
Total pesos fijos			105,250			124,458			0,000	28,559
Total Loadcase			99144,377	209406,816	145152,538	131,517			0,000	14,630

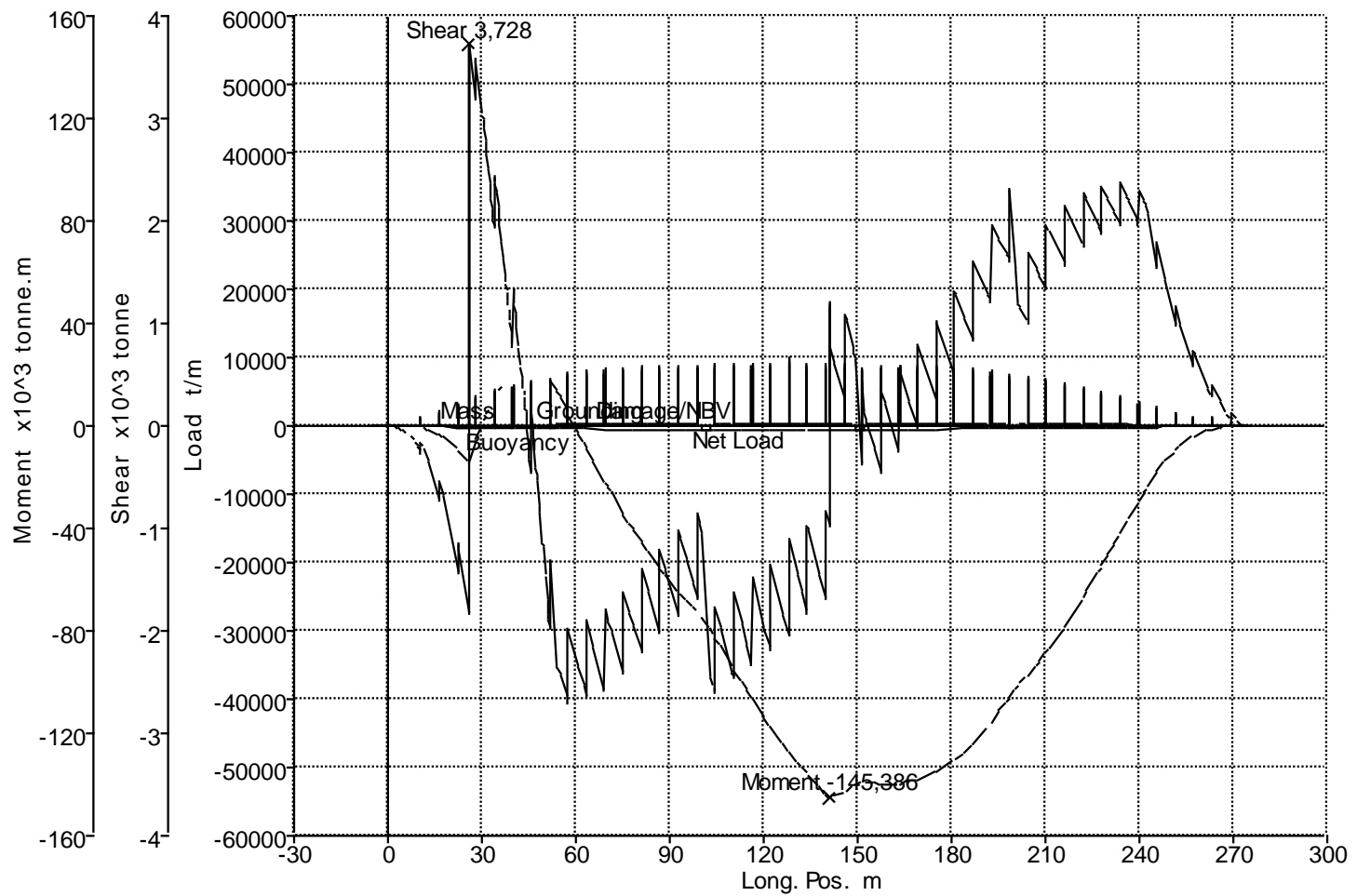

- Longitudinal Strength**
- Mass
 - Buoyancy
 - Grounding
 - Damage/NBV
 - Net Load
 - Shear
 - Moment

Name	Long. Pos. m	Mass t/m	Buoyancy t/m	Grounding t/m	Damage/NBV t/m	Net Load t/m	Shear x10 ³ tonne	Moment x10 ³ tonne.m
-1/4	-5,304	0,000	0,000	0,000	0,000	0,000	0,000	0,000
0	-1,933	0,000	-0,024	0,000	0,000	-0,024	0,000	0,000
1/2	4,810	0,000	-23,991	0,000	0,000	-23,991	-0,048	-0,081
1	11,552	0,000	-80,793	0,000	0,000	-80,793	-0,246	-1,087
1 1/2	18,295	0,000	-145,818	0,000	0,000	-145,818	-0,813	-4,941
2	25,037	0,000	-214,413	0,000	0,000	-214,413	-1,705	-13,257
2 1/2	31,780	1,307	-293,154	0,000	0,000	-291,847	2,595	5,517
3	38,522	59,919	-347,895	0,000	0,000	-287,976	1,143	18,704
4	52,007	0,000	-416,383	0,000	0,000	-416,383	-1,455	16,828
5	65,492	338,678	-460,124	0,000	0,000	-121,446	-2,143	-13,430
6	78,977	382,959	-484,721	0,000	0,000	-101,762	-2,010	-41,761
7	92,462	382,465	-497,189	0,000	0,000	-114,724	-1,823	-64,488
8	105,947	383,212	-503,924	0,000	0,000	-120,712	-1,935	-85,595
9	119,432	382,720	-506,501	0,000	0,000	-123,781	-1,868	-112,428
10	132,917	382,225	-505,513	0,000	0,000	-123,288	-1,711	-134,716
11	146,402	381,727	-500,963	0,000	0,000	-119,236	1,009	-142,303
12	159,887	383,036	-492,841	0,000	0,000	-109,805	0,107	-139,803
13	173,372	382,543	-480,521	0,000	0,000	-97,979	0,380	-136,125
14	186,857	382,047	-459,127	0,000	0,000	-77,080	1,610	-124,401
15	200,342	0,000	-424,352	0,000	0,000	-424,352	1,560	-102,239
16	213,827	287,920	-358,911	0,000	0,000	-70,990	1,724	-82,231
17	227,312	211,306	-278,629	0,000	0,000	-67,323	1,908	-55,777
17 1/2	234,055	170,651	-237,819	0,000	0,000	-67,168	2,354	-41,395
18	240,797	121,823	-192,138	0,000	0,000	-70,315	2,226	-26,714
18 1/2	247,540	0,000	-145,103	0,000	0,000	-145,103	1,493	-14,394
19	254,282	0,000	-101,231	0,000	0,000	-101,231	0,872	-6,785
19 1/2	261,025	0,000	-72,695	0,000	0,000	-72,695	0,438	-2,395
20	267,767	0,000	-51,766	0,000	0,000	-51,766	0,117	-0,337
20 1/4	271,138	0,000	-28,943	0,000	0,000	-28,943	0,045	-0,056
20 1/2	274,510	0,000	-4,745	0,000	0,000	-4,745	0,003	-0,002

Longitudinal Strength Calculation - ANALIZADO DEFINITIVO

Stability 20.00.04.9, build: 9

Model file: C:\Users\Usuario\Desktop\TFG\CUADERNO 5\ANALIZADO DEFINITIVO (Medium precision, 65 sections, Trimming off, Skin thickness not applied).

Long. datum: AP; Vert. datum: Baseline. Analysis tolerance - ideal(worst case): Disp. %: 0,01000(0,100); Trim%(LCG-TCG): 0,01000(0,100); Heel%(LCG-TCG): 0,01000(0,100)

Loadcase - C4 Llegada a puerto en lastre

Damage Case - Intact

Free to Trim

Specific gravity = 1,025; (Density = 1,025 tonne/m³)

Fluid analysis method: Simulate fluid movement

Item Name	Quantity	Unit Mass tonne	Total Mass tonne	Unit Volume m ³	Total Volume m ³	Long. Arm m	Aft. Limit m	Fwd. Limit m	Trans. Arm m	Vert. Arm m
rosca	1	36099,280	36099,280			116,086			0,000	13,421
Total rosca			36099,280			116,086			0,000	13,421
Tanque 4	0%	17383,695	0,000	40427,198	0,000	77,260			0,000	2,500
Tanque 3	0%	18236,208	0,000	42409,786	0,000	103,423			0,000	2,500
Tanque 2	0%	18216,099	0,000	42363,021	0,000	152,448			0,000	2,500
Tanque 1	0%	10179,370	0,000	23672,952	0,000	201,441			0,000	2,500
Total carga	0%	64015,373	0,000	148872,958	0,000	0,000			0,000	0,000
Pique PP BR	100%	2703,969	2703,969	2638,019	2638,019	3,809			-8,973	19,875
Pique PP ER	100%	2704,001	2704,001	2638,050	2638,050	3,809			8,973	19,875
Cofferdam 5	100%	2150,709	2150,709	2098,253	2098,253	52,770			0,000	17,477
Cofferdam 4	100%	2608,203	2608,203	2544,588	2544,588	101,772			0,000	15,460
Cofferdam 3	100%	2608,196	2608,196	2544,581	2544,581	150,798			0,000	15,460
Cofferdam 2	100%	2512,692	2512,692	2451,407	2451,407	199,813			0,000	15,509
Cofferdam 1	100%	717,353	717,353	699,857	699,857	243,256			0,000	17,484
Pique PR BR	100%	411,594	411,594	401,555	401,555	268,098			-1,679	15,907
Pique PR ER	100%	411,594	411,594	401,555	401,555	268,098			1,679	15,907
Lastre 4 BR	100%	4509,134	4509,134	4399,155	4399,155	77,576			-15,302	9,501
Lastre 4 ER	100%	4509,134	4509,134	4399,155	4399,155	77,576			15,302	9,501
Lastre 3 BR	100%	5368,684	5368,684	5237,740	5237,740	124,977			-15,690	8,340
Lastre 3 ER	100%	5368,684	5368,684	5237,740	5237,740	124,977			15,690	8,340
Lastre 2 BR	100%	4765,443	4765,443	4649,212	4649,212	172,522			-15,153	8,809
Lastre 2 ER	100%	4765,443	4765,443	4649,212	4649,212	172,522			15,153	8,809
Lastre 1 BR	100%	4575,151	4575,151	4463,562	4463,562	222,028			-13,012	14,284
Lastre 1 ER	100%	4575,151	4575,151	4463,562	4463,562	222,028			13,012	14,284
Total lastre	100%	55265,135	55265,135	53917,205	53917,205	134,036			0,000	12,308
Agua dulce BR	5%	76,795	3,840	76,795	3,840	8,521			-1,352	21,026
Agua dulce ER	5%	76,795	3,840	76,795	3,840	8,521			1,352	21,026

Aceite BR	5%	49,417	2,471	54,908	2,745	32,001			-17,140	21,096
Aceite ER	5%	49,417	2,471	54,908	2,745	32,001			17,140	21,096
FO UD BR	100%	92,783	92,783	95,653	95,653	36,305			-16,790	22,490
FO UD ER	100%	92,783	92,783	95,653	95,653	36,305			16,790	22,490
FO Sed. BR	91,87%	139,540	128,195	143,855	132,160	41,228			-16,440	21,924
FO Sed. ER	91,87%	139,540	128,195	143,855	132,160	41,228			16,440	21,924
Diesel BR	5%	382,873	19,144	425,414	21,271	47,440			-15,230	17,479
Diesel ER	5%	382,873	19,144	425,414	21,271	47,440			15,230	17,479
Aguas grises	100%	238,468	238,468	158,979	158,979	47,383			0,000	1,318
Lodos	100%	113,158	113,158	75,439	75,439	40,477			0,000	1,302
FO Almacén	0%	2322,658	0,000	2394,493	0,000	244,768			-3,122	2,500
FO Almacén	0%	2322,658	0,000	2394,493	0,000	244,768			3,122	2,500
Viveres	1	0,438	0,438			57,000	57,000	57,000	0,000	39,200
Total consumos			844,930			41,722			0,000	13,265
Tripulacion	1	5,250	5,250			57,000	57,000	57,000	0,000	39,200
Perterechos	1	100,000	100,000			128,000	128,000	128,000	0,000	28,000
Total pesos fijos			105,250			124,458			0,000	28,559
Total Loadcase			92314,594	209406,816	54662,959	126,161			0,000	12,771

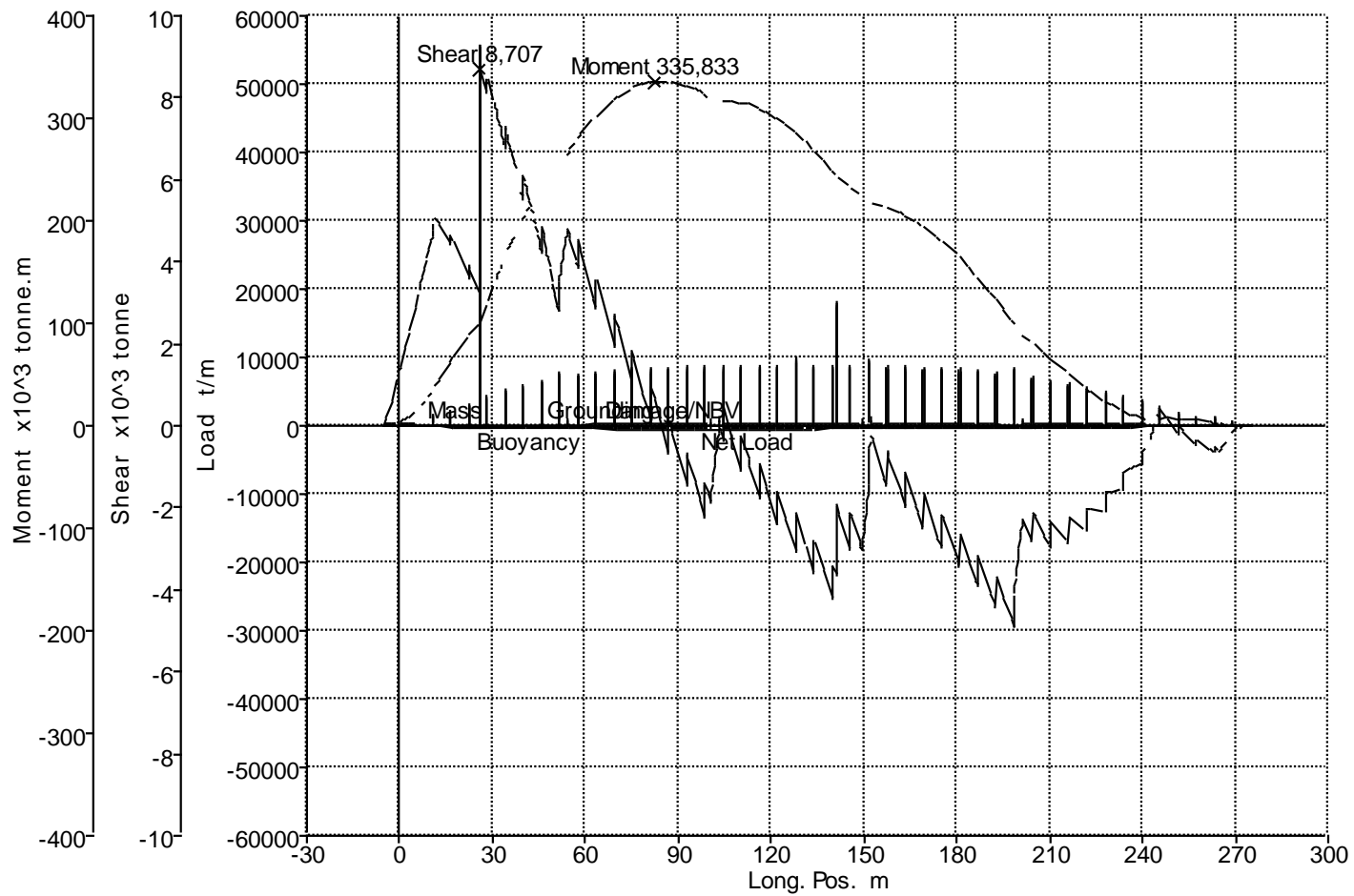

Longitudinal Strength

- Mass
- Buoyancy
- Grounding
- Damage/NBV
- Net Load
- Shear
- Moment

Name	Long. Pos. m	Mass t/m	Buoyancy t/m	Grounding t/m	Damage/NBV t/m	Net Load t/m	Shear x10 ³ tonne	Moment x10 ³ tonne.m
-1/4	-5,304	0,000	0,000	0,000	0,000	0,000	0,000	0,000
0	-1,933	280,725	-1,071	0,000	0,000	279,653	0,825	1,377
1/2	4,810	351,290	-34,679	0,000	0,000	316,611	2,856	13,530
1	11,552	0,000	-99,453	0,000	0,000	-99,453	5,025	40,133
1 1/2	18,295	0,000	-167,089	0,000	0,000	-167,089	4,321	71,346
2	25,037	0,000	-233,892	0,000	0,000	-233,892	3,289	97,158
2 1/2	31,780	1,332	-309,687	0,000	0,000	-308,355	7,466	149,180
3	38,522	59,919	-361,893	0,000	0,000	-301,974	5,910	194,848
4	52,007	923,604	-423,507	0,000	0,000	500,098	3,731	256,518
5	65,492	169,711	-460,527	0,000	0,000	-290,817	3,007	307,936
6	78,977	193,515	-478,453	0,000	0,000	-284,938	0,719	333,900
7	92,462	207,772	-484,016	0,000	0,000	-276,244	-1,408	331,976
8	105,947	216,107	-483,835	0,000	0,000	-267,727	0,073	317,367
9	119,432	220,002	-479,432	0,000	0,000	-259,430	-1,762	304,753
10	132,917	220,824	-471,506	0,000	0,000	-250,683	-3,372	271,819
11	146,402	218,578	-459,997	0,000	0,000	-241,418	-2,332	230,522
12	159,887	212,352	-444,994	0,000	0,000	-232,642	-1,219	210,017
13	173,372	201,754	-425,857	0,000	0,000	-224,103	-2,622	184,840
14	186,857	178,314	-398,523	0,000	0,000	-220,209	-3,165	144,288
15	200,342	1055,776	-359,219	0,000	0,000	696,557	-2,855	90,560
16	213,827	207,668	-294,741	0,000	0,000	-87,073	-2,654	55,987
17	227,312	218,326	-221,380	0,000	0,000	-3,054	-2,101	24,766
17 1/2	234,055	213,818	-186,259	0,000	0,000	27,560	-1,120	13,823
18	240,797	181,330	-148,668	0,000	0,000	32,661	-0,566	7,351
18 1/2	247,540	0,000	-111,317	0,000	0,000	-111,317	0,205	7,164
19	254,282	0,000	-77,960	0,000	0,000	-77,960	-0,226	6,789
19 1/2	261,025	0,000	-56,641	0,000	0,000	-56,641	-0,532	4,216
20	267,767	128,301	-39,177	0,000	0,000	89,123	-0,323	0,675
20 1/4	271,138	53,039	-23,335	0,000	0,000	29,705	-0,062	0,100
20 1/2	274,510	7,034	-4,050	0,000	0,000	2,984	-0,002	0,003