

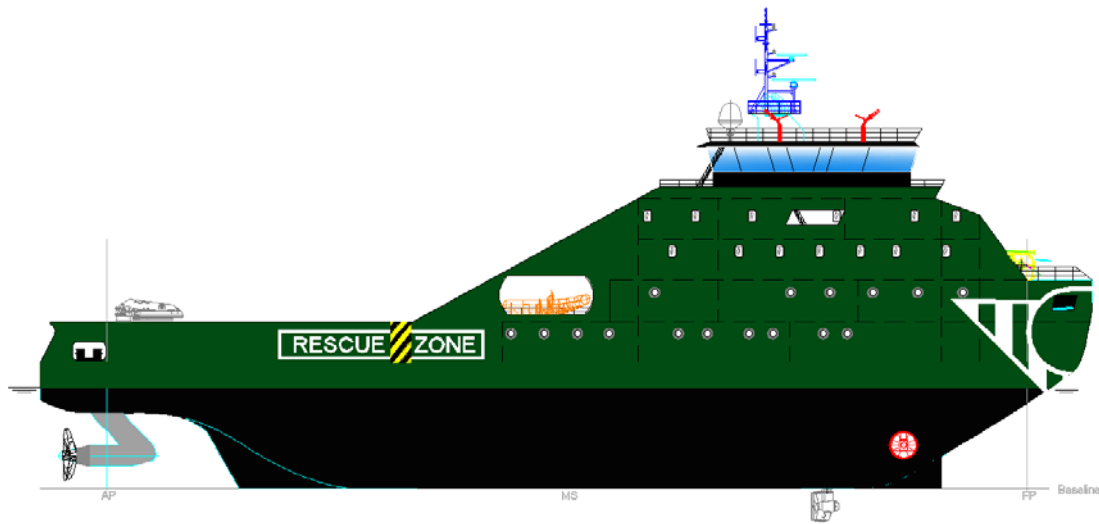

Escola Politécnica Superior

UNIVERSIDADE DA CORUÑA

Proyecto número: 14-04 REMOLCADOR ROMPEHIELOS



CUADERNO 6: Predicción de Potencia y diseño de propulsores

ALUMNO: MIGUEL PÉREZ-LAFUENTE RECUNA



DEPARTAMENTO DE INGENIERÍA NAVAL Y OCEÁNICA

ANTEPROYECTO Y PROYECTO FIN DE CARRERA

CURSO 2.013-2014

PROYECTO NÚMERO 14- 04

TIPO DE BUQUE: Buque remolcador rompehielos de 100 TPF OPERACIONES EN PUERTO CON ALTO NIVEL DE HIELO PARA ESCOLTA DE GRANDES BUQUES Y OPERACIONES ROMPEHIELOS

CLASIFICACIÓN, COTA Y REGLAMENTOS DE APLICACIÓN: REGISTRO RUSO, KM, SOLAS, MARPOL, DYNPOS-1, Icebreaker6, FF3WS, AUT1-ICS, OMBO, EPP, ECO-S, Oil recovery ship (>60°C), Tug

CARACTERÍSTICAS DE LA CARGA: 100 TPF 2000 TPM 400 M2 DE SUPERFICIE DE CUBIERTA

VELOCIDAD Y AUTONOMÍA: 15 nudos en condiciones de servicio 80% MCR y 18% MM

SISTEMAS Y EQUIPOS DE CARGA / DESCARGA: Maquinilla de remolque en cubierta y en proa. Grúa en cubierta

PROPULSIÓN: Diésel eléctrica MDO, AZIPODS EN PROA Y POPA, 10 MW DE POTENCIA

TRIPULACIÓN Y PASAJE: 30 personas de tripulación 40 náufragos

OTROS EQUIPOS E INSTALACIONES: Los habituales en este tipo de buques

Ferrol, Febrero de 2.014

ALUMNO: D. MIGUEL PÉREZ-LAFUENTE RECUNA



ÍNDICE

1. Presentación.....	5
2. Planteamiento de la Planta Propulsora.....	5
3. Cálculo de la Resistencia al Avance del Buque.....	6
4. Propulsor AziPod.....	10
5. Predicción de Potencia: Navegación Libre.....	11
6. Predicción de Potencia: Remolque.....	14
7. Dimensionamiento del Propulsor.....	15
8. Características Geométricas del Propulsor.....	19
9. Cálculo del Timón.....	20
10. Comprobación del Codaste.....	21
<i>ANEXO I: Datos de partida.....</i>	<i>22</i>
<i>ANEXO II: Reports Resistencia al Avance.....</i>	<i>25</i>
<i>ANEXO III: Información Propulsor AziPod.....</i>	<i>30</i>
<i>ANEXO IV: Reports Navegación Libre.....</i>	<i>32</i>
<i>ANEXO V: Reports Condición de Remolque.....</i>	<i>45</i>
<i>ANEXO VI: Reports Predicción por Potencia.....</i>	<i>50</i>
<i>ANEXO VII: Report Dimensionamiento de Propulsor..</i>	<i>59</i>
<i>ANEXO VIII: Plano Codaste.....</i>	<i>61</i>



1. Presentación

En este cuaderno se definirán los propulsores del buque.

En primer lugar se calculará la resistencia al avance del buque y a continuación la potencia necesaria para moverlo a la velocidad de diseño, para a partir de ahí dimensionar el propulsor.

Para los cálculos tanto de la resistencia, potencia y propulsor, se utilizará el programa NavCad.

Además de la predicción de potencia para navegación en aguas libres, se realizará una predicción de potencia de tiro, dada la condición de remolcador del buque de este proyecto.

El buque debe cumplir dos condiciones del RPA:

- 100 toneladas de tracción a punto fijo.
- 15 nudos de navegación en condiciones de servicio.

Para ello, el buque contará con una planta propulsora Diésel – eléctrica con propulsores AziPod en popa, y un propulsor azimuth retráctil en proa.

Por último y pese a no necesitarlo por ser propulsión AziPod, se realizará un cálculo teórico del timón.

Las dimensiones principales del buque son:

L _{pp} (m)	58,25	$\Delta(T_n)$	4495
L _{total} (m)	66,60	C _b	0,66
B (m)	16,20	Potencia (kW)	10660
D (m)	8,00	Vel. Servicio (nudos)	15
T (m)	6,40	Área de Cubierta (m ²)	402,12

Sus características principales son la de rompehielos y la de remolcador. A mayores, este buque tiene sistemas de succión de aceites en la superficie del mar, cuenta con equipo de rescate y con equipos para combatir incendios en otros buques.

2. Planteamiento de la Planta Propulsora

Además de la potencia necesaria para la navegación del buque, también se necesita una potencia determinada para trabajos de remolque.

Los valores de estas potencias calculados en el Cuaderno 1 son:

Potencia máxima: requerida para dar el tiro a punto fijo. Se obtiene mediante una regresión (TPF(Tn) – Potencia(hp)). El valor obtenido es 7520 kW.

La potencia obtenida mediante NavCad para la navegación a 15 nudos es de 7186 kW.

En este cuaderno se volverán a calcular las potencias necesarias y además se dimensionará el propulsor del buque.

En el RPA del proyecto, el requisito en cuanto a propulsión es:

- Diésel eléctrica (Marine Diésel Oil), propulsores AziPod,
- Potencia total mínima: 10 MW.

La planta propulsora contará con:

- 4 diésel generadores encargados de suministrar potencia suficiente para satisfacer la potencia total requerida del buque.
- 2 propulsores AziPod eléctricos con potencia suficiente para la propulsión.

Se ha tomado como ejemplo la planta propulsora del buque de la base de datos “Fesco Sakhalin”, los requerimientos de RPA y la posibilidad de navegar a la velocidad de diseño con un diésel generador averiado.

A continuación se muestra un esquema de la propulsión escogida:

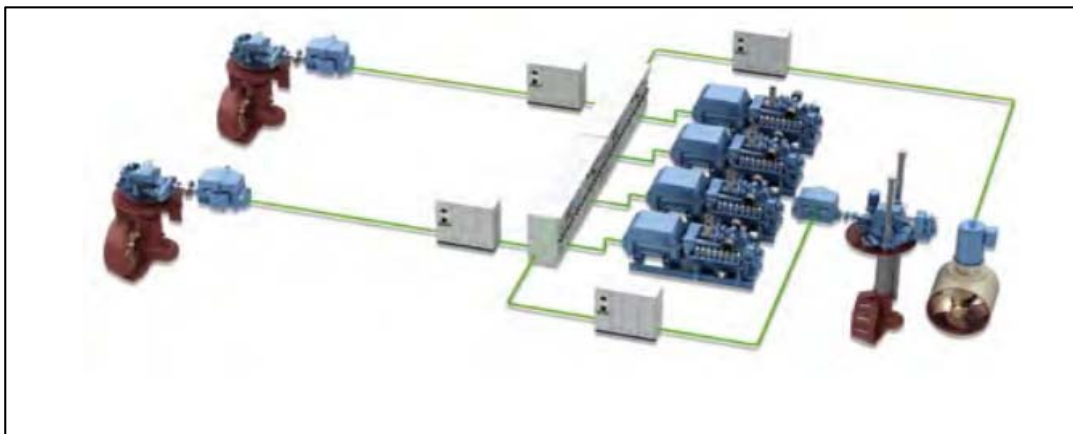

Los propulsores serán tipo AziPod y no azimuth como en la imagen

3. Cálculo de la Resistencia al Avance del Buque

Para calcular la resistencia al avance se utilizará el programa NavCad, introduciendo distintos valores, dimensiones y coeficientes del buque.

Los datos que se introducirán en el programa se tomarán en primer lugar de los obtenidos con el programa 'MaxSurf Resistance', y se completará con las hidrostáticas del buque al calado de diseño. Ambos datos presentados en el ANEXO I.

Los datos introducidos son los siguientes:

- *Condition:* Se definen los parámetros principales del buque, el tipo de propulsión, las propiedades del fluido y un rango de velocidades.

Project		
Project ID:	Remolcador Rom...	
Description:		
Summary		
Scope:	ITTC-78 (CT)	
Configuration:	Monohull	
Chine type:	Round/multiple	
Length on WL:	63,961	m
Displacement:	4495,00	t
Propulsor type:	Propeller	
Count:	2	
Water properties		
Water type:	Salt	
Density:	1026,00	kg/m ³
Viscosity:	1,18920e-6	m ² /s
Speeds		
Speed [01]	0,10	kt
Speed [02]	2,00	kt
Speed [03]	4,00	kt
Speed [04]	6,00	kt
Speed [05]	8,00	kt
Speed [06]	10,00	kt
Speed [07]	12,00	kt
Speed [08]	14,00	kt
Speed [09]	15,00	kt
Speed [10]	16,00	kt
Design condition		
Design speed:	15,00	kt

- *Hull:* Se definen las características geométricas principales del buque.

Hull		
Configuration:	Monohull	
Chine type:	Round/multiple	
General		
Length on WL:	63,961	m
Max beam on WL:	16,200	m
Max molded draft:	6,400	m
Displacement:	4495,00	t
Wetted surface:	1469,2	m ²
Demi-hull spacing:		m
ITTC-78 (CT)		
LCB fwd TR:	32,825	m
LCF fwd TR:	29,722	m
Max section area:	101,0	m ²
Waterplane area:	942,5	m ²
Bulb section area:	3,3	m ²
Bulb ctr below WL:	6,013	m
Bulb nose fwd TR:	57,000	m
Imm transom area:	9,6	m ²
Transom beam WL:	14,731	m
Transom immersion:	0,800	m
Half entrance angle:	32,80	deg
Bow shape factor:	0,0	[AVG flow]
Stern shape factor:	0,0	[AVG flow]

Aunque el buque no tiene bulbo en proa, se le ha instalado un talón para labores de rompehielos, como se justifica en el Cuaderno 3. El programa MaxSurf Resistance interpreta dicho talón como bulbo y los parámetros que proporciona se han introducido igualmente en el programa.

A los valores de LCB y LCF de las hidrostáticas se le suma la parte a popa de la perpendicular de popa (4,24 m).

- *Appendage:* En este apartado se calculará por predicción por porcentaje, estableciendo como valor el 5% del casco.

Appendage		
Definition:	Percentage	
Percent of hull drag:	5,00	%
Planing influence		
LCE fwd TR:		m
VCE below WL:		m

- *Environment:* Se definen las condiciones meteorológicas. Este apartado no se tendrá en cuenta ya que se introducirá un margen de mar para cubrir estos posibles efectos.

Wind		
Wind speed:	0,00	kt
Angle off bow:	0,00	deg
Gradient correction:	Off	
Exposed hull		
Transverse area:	0,0	m ²
VCE above WL:	0,000	m
Profile area:	0,0	m ²
Superstructure		
Superstructure shape:	Cargo ship	
Transverse area:	0,0	m ²
VCE above WL:	0,000	m
Profile area:	0,0	m ²
Seas		
Significant wave ht:	0,000	m
Modal wave period:	0,0	sec
Shallow/channel		
Water depth:	0,000	m
Type:	Shallow water	
Channel width:		m
Channel side slope:		deg
Hull girth:		m

- *Misc:* Se define el margen de mar. Por RPA se define un margen de mar del 18%.

Margin		
Design margin:	18	%
Basis:	Hull + added dr...	

Una vez rellenos los distintos campos, se especifican las condiciones del análisis de la resistencia al avance del buque. El tipo de predicción es sugerido por el programa, y se escogerá el más adecuado.

Vessel drag	Calc	ITTC-78 (CT)
Technique:		Prediction
Prediction:		Holtrop
Reference ship:		
Model LWL:	[m]	
Viscous		
Expansion:		Standard
Friction line:		ITTC-57
Hull form factor:	On	1,319
Speed corr:	On	
Spray drag corr:	Off	
Corr allowance:		ITTC-78 (v2008)
Roughness [mm]:	On	0,15
Catamaran		
Interference:	Off	
Added drag		
Appendage:	Calc	Percentage
Wind:	Off	
Seas:	Off	
Shallow/channel:	Off	
Towed:	Off	
Margin:	Calc	Hull + added drag [18...

Los resultados obtenidos por NavCad se presentan en el ANEXO II.

Resistencia al avance:

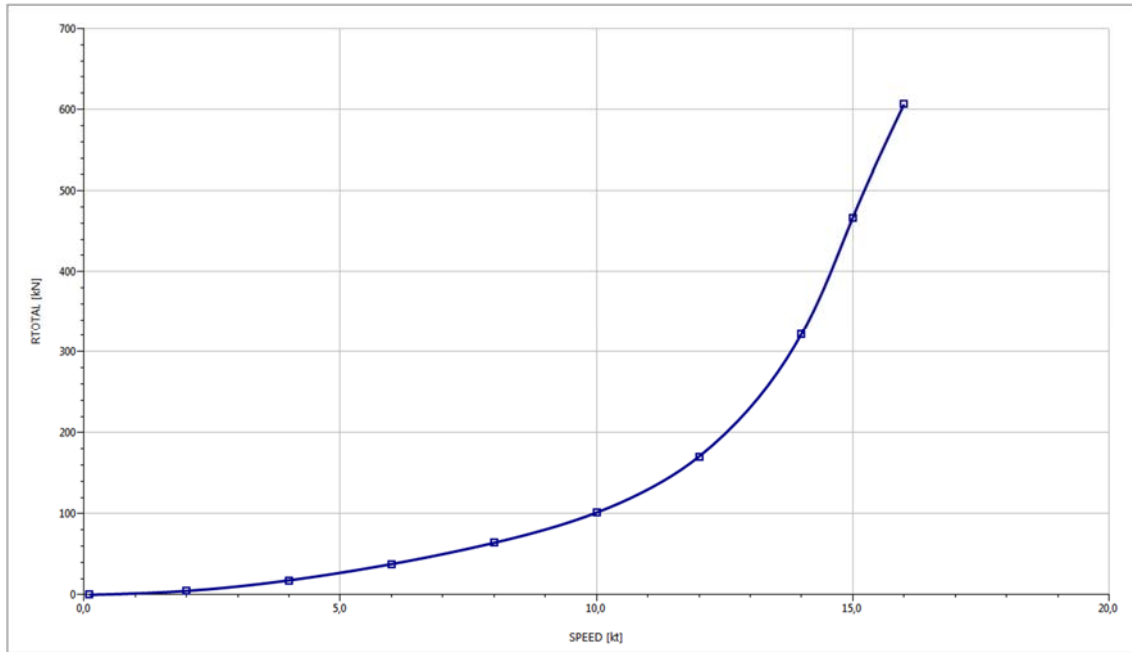

La resistencia total obtenida es de: $R_t = 466,79 \text{ KN}$

Potencia efectiva:

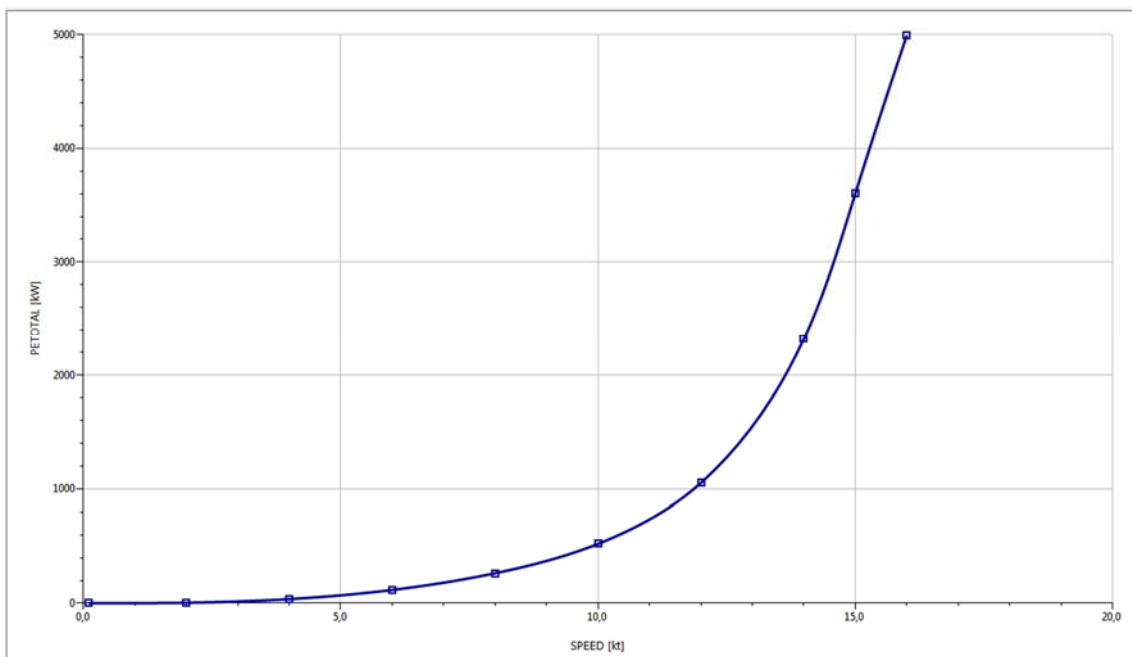

La potencia efectiva total obtenida es de: $P_e = 3602,0 \text{ kW}$



La potencia efectiva es la potencia que debe entregarse al propulsor para superar la resistencia al avance, pero no es la misma que la potencia que tiene el conjunto de diésel generadores, ya que se deben tener en cuenta distintos rendimientos.

La potencia del motor será superior a la potencia efectiva.

Dicha potencia se conocerá como PB o BHP (Brake HorsePower), o potencia al freno.

4. Propulsor AziPod

Por requisitos de RPA, los propulsores del buque serán 2 AziPods, además de un azimuth retráctil en proa. Se elegirá un tipo de AziPod con potencia suficiente tanto para la navegación en aguas libres como para la navegación en remolque.

Para seleccionar los propulsores AziPod se realizará una predicción de potencia a remolque para tener un valor de referencia de potencia de propulsión. La potencia obtenida por dimensionamiento es de 7520 kW.

Como la potencia para remolque requerida es superior a la de navegación en aguas libres, el dimensionamiento en el cálculo de remolque se realizará por potencia introduciendo los valores propios del propulsor escogido (curva de potencia frente a revoluciones, diámetros máximos....).

El propulsor final escogido es de la marca ABB, modelo CO 1400, cuya información se presenta en el ANEXO III.

Se realizará el cálculo del propulsor para 4, 5 y 6 palas en la predicción de potencia en navegación libre (ésta se realizará por empuje y no por potencia) para realizar una comparación.

Se escogen estos números de pala ya que son los comunes en propulsores AziPod.

El dimensionamiento de los propulsores se hará mediante las series sistemáticas 'B series' como si fuera un propulsor normal, ya que el programa no incluye un método de cálculo para propulsores AziPod.

5. Predicción de Potencia: Navegación Libre

A continuación se estimará la potencia al freno en condiciones de navegación libre. Los parámetros más importantes a tener en cuenta son la velocidad de servicio del buque (15 nudos), y que se dimensionará el propulsor mediante empuje, es decir, a partir de la resistencia al avance obtenida en el apartado anterior para la misma velocidad.

Se introducen los siguientes datos:

- Número de propulsores: 2.
- Tipo de propulsor: FPP.
- Serie propulsor: B series
- Dimensionamiento: By thrust.
- N^o palas: 4, 5 y 6.
- Diámetro de la hélice: 4,00 m.
- Inmersión de eje: 4,4 m
- Rendimiento de reductora : 1 (No hay reductora)
- Rendimiento de eje: 1 (Directamente acoplado).
- Corrección por propulsor no alineado con eje: No.

El resto de parámetros son valores a dimensionar.

- La técnica de predicción será Holtrop, al igual que el método de obtención del factor de forma.
- Se considerará una rugosidad de 0,15 mm (condición de buque nuevo).
- El criterio de cavitación utilizado será el de Keller.

Propulsor		
Count:	2	
Propulsor type:	Propeller series	
Propeller type:	FPP	
Propeller series:	B Series	
Propeller sizing:	By thrust	
Reference prop:		
Blade count:	4	
Expanded area ratio:	0,4772	
Propeller diameter:	3379,0	mm
Propeller mean pitch:	2669,6	mm
Hub immersion:	4400,0	mm
Engine/gear		
Engine data:	AziPod CO1400	
Rated RPM:	220	RPM
Rated power:	4500,0	kW
Gear efficiency:	1,000	
Load correction:	Off	
Gear ratio:	1,000	
Shaft efficiency:	1,000	
Propeller options		
Oblique angle corr:	Off	
Shaft angle to WL:	0,00	deg
Added rise of run:	0,00	deg
Propeller cup:	0,0	mm
KTQ corrections:	Custom	
Scale correction:	None	
KT multiplier:	1,000	
KQ multiplier:	1,000	
Blade T/C [0.7R]:	0,00	
Roughness:	0,00	mm
Cav breakdown:	Off	
Nozzle L/D:	0,50	

El siguiente paso es dimensionar el propulsor y calcular la potencia al freno necesaria. Se introducirán en la ventana de *propeller sizing* los siguientes datos:

- Diámetro máximo: 4,00 m
- Velocidad de diseño: 15 nudos.
- Empuje: valor obtenido de resistencia total.
- Punto de diseño: 1
- Revoluciones de referencia: 220 rpm
- Punto de diseño: 1

To size			
Gear ratio:	Keep	1,00	
Expanded area ratio:	Size	0,477	
Propeller diameter:	Size	3379,0	mm
Propeller mean pitch:	Size	2669,6	mm
Design condition			
Design speed:		15,00	kt
Reference thrust:		271,60	kN
Design point:		1,000	=
Reference RPM:		220,0	=
Design point:		1,000	=
Max prop diam:		4000,0	mm
Review			
Tip speed:		38,92	m/s

El valor de las revoluciones es el del punto de diseño del propulsor. En el ANEXO III se presenta su información técnica.

El resto de valores serán dimensionados por el programa, excepto el correspondiente a la caja reductora, que se mantendrá en 1 mediante la opción Keep, debido a que no hay reductora.

Los resultados para 4, 5 y 6 palas se presentan en el ANEXO IV, que se resumen en la siguiente tabla:

Nº de Palas	EFFOA	PB TOTAL (kW)
4	0,6077	5927,3
5	0,5896	6109,6
6	0,5798	6213,0

Según esta comparativa, la mejor opción es una hélice de 4 palas, tanto por rendimiento como por potencia necesaria. Las imágenes mostradas corresponden a un propulsor de 4 palas, ya que es la mejor opción de las estudiadas.

La potencia al freno necesaria para la navegación del buque a la velocidad de servicio (15 nudos) es de 5927,3 kW.

Esta potencia es la mínima que deben proporcionar los motores al 85 % de su régimen, por lo que la potencia final será de:

$$PB \text{ final} = \frac{5927,3}{0,85} = 6973,30 \text{ kW}$$

El valor obtenido es similar al calculado en el Cuaderno 1 (7186 kW).

Las gráficas correspondientes al propulsor de 4 palas se muestran a continuación:

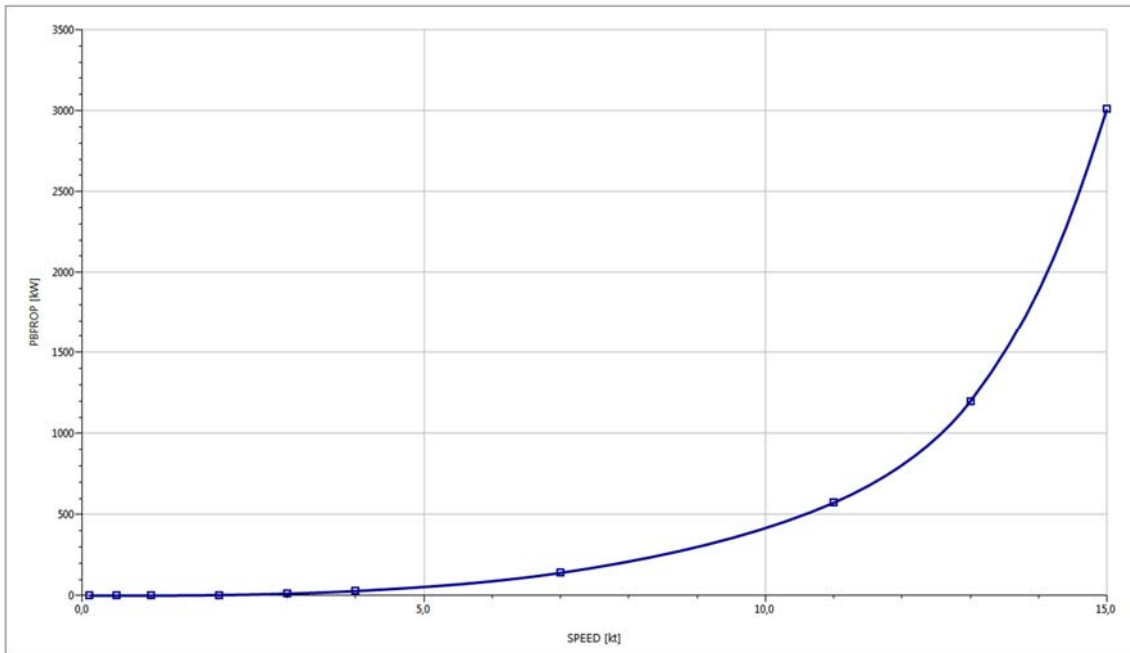

Gráfica Potencia al freno frente a Velocidad

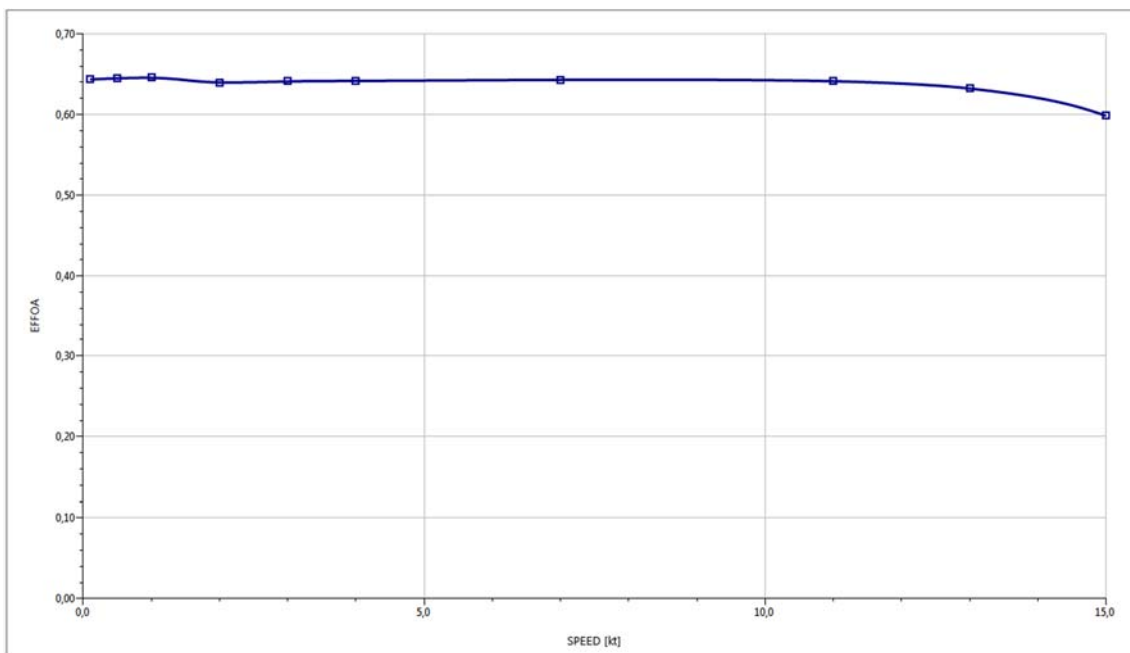

Gráfica Rendimiento frente a Velocidad

6. Predicción de Potencia: Remolque

Realizaremos una primera predicción de potencia para obtener un valor de referencia y poder elegir propulsores AziPod adecuados.

El tiro necesario es de 100 TPF. El valor obtenido en el Cuaderno 1 mediante dimensionamiento es de 7520 kW.

Mediante el programa NavCad obtendremos el valor final, procediendo de manera semejante al anterior apartado pero realizando esta vez la propulsión para la condición de remolque.

El número de palas estudiadas será 4 al ser el número para el cual se obtenía el mejor rendimiento, tal y como se demostró en el anterior apartado.

Se obtiene el siguiente dimensionamiento:

To size			
Gear ratio:	Keep	▼	1,00
Expanded area ratio:	Size	▼	0,477
Propeller diameter:	Size	▼	3379,0 mm
Propeller mean pitch:	Size	▼	2669,6 mm
Design condition			
Design speed:		▼	15,00 kt
Reference thrust:		=	271,60 kN
Design point:		=	1,000
Reference RPM:		=	220,0
Design point:		=	1,000
Max prop diam:		=	4000,0 mm
Review			
Tip speed:		=	38,92 !! m/s

Los resultados de esta predicción se presentan en el ANEXO V.

Según esta predicción se requiere una potencia de 8997,8 kW para conseguir una tracción de 897,32 KN a la velocidad de 0,1 nudos. Pasando este valor a toneladas se obtiene que:

$$TPF = \frac{901,79}{9,81} = 91,47 Tn$$

Aunque el valor obtenido no llega a los 100 TPF requeridos, se toma por válida la potencia de referencia: 9000 kW.

En el siguiente apartado se introducirán los datos del propulsor AziPod y se dimensionará la hélice por potencia para obtener el valor final de tracción.

7. Dimensionamiento del Propulsor

En este apartado se comprobará que el propulsor AziPod escogido para el buque cumple con el tiro necesario (100 TPF), y se procederá al dimensionamiento del mismo.

Para calcular el valor final se procederá como en el apartado anterior pero con algunas variaciones:

- Dimensionamiento: “By power”.
- Tipo de análisis: “Towing”.
- Velocidades estudiadas: Se modificarán los valores de las velocidades estudiadas respecto a los valores en los cálculos anteriores.

Para el dimensionamiento por potencia, se introduce en el programa la curva de potencia (kW) frente a revoluciones (rpm) del propulsor escogido (CO1400):

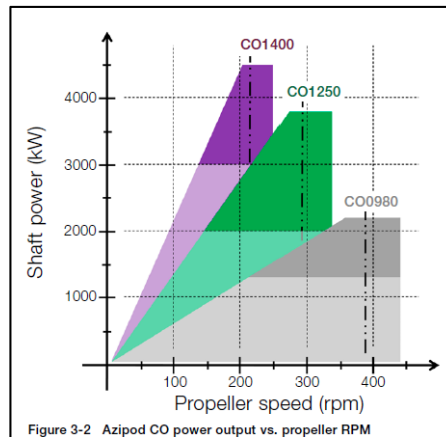
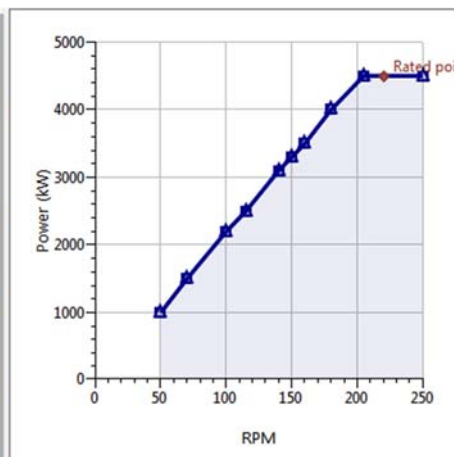

Figure 3-2 Azipod CO power output vs. propeller RPM

Properties		
Description:	AziPod CO1400	
Import file:	D:\azipod.egn	
Data source:	Defined	
Units		
Power:	[0.0]	kW
Fuel rate:	[0.00]	L/h
Fuel density:	[0.00]	kg/m3
Heating value:	[0]	J/g
Rating		
Rated power:	4500,0	kW
Rated RPM:	220	
Parasitic load:	0,0	kW
Idle (unclutched)		
Power:	0,0	kW
RPM:	0	
Fuel rate:	0,00	L/h
Fuel basis		
Type:	Marine Die...	
Density:	0,00	kg/m3
Heating value:	0	J/g



MAX POWER CURVE			
	RPM	Power	Fuel
1	250	4500,0	0,00
2	205	4500,0	0,00
3	180	4000,0	0,00
4	160	3500,0	0,00
5	150	3300,0	0,00
6	140	3100,0	0,00
7	115	2500,0	0,00
8	100	2200,0	0,00
9	70	1500,0	0,00
10	50	1000,0	0,00

DEFINED LOAD CURVE			
	RPM	Power	Fuel
1	250	4500,0	0,00
2	205	4500,0	0,00
3	180	4000,0	0,00
4	160	3500,0	0,00
5	150	3300,0	0,00
6	140	3100,0	0,00
7	115	2500,0	0,00
8	100	2200,0	0,00
9	70	1500,0	0,00
10	50	1000,0	0,00



A continuación se evaluará el comportamiento para cada propulsor obtenido a las distintas velocidades fijadas (distintas iteraciones para obtener el propulsor más adecuado), en la condición de navegación.

El valor del paso de la hélice se ha ajustado después de dimensionar para maximizar la potencia de tiro. Para esto se ha aproximado el valor dimensionado hacia abajo.

El valor del diámetro de la hélice se fija en el valor máximo para mejorar el tiro del buque.

Se obtiene la siguiente tabla resumen con los valores obtenidos para los dimensionamientos a las distintas velocidades:

Velocidad de diseño (nudos)	TPF obtenido		EFOA en navegación a 15 nudos
	KN	Tn	
0,1	925,43	94,34	0,5485
0,5	927,23	94,52	0,5488
1	954,98	97,35	0,5299
2	977,01	99,59	0,5091
3	1009,42	102,90	0,3946
4	1021,24	104,10	0,4259
7	1021,58	104,14	0,4811
11	992,68	101,19	0,5303
13	956,87	97,54	0,5515
15	925,63	94,36	0,5797

De estos resultados se escogerá la configuración que aporte mayor tracción a punto fijo con un mayor rendimiento en navegación a 15 nudos.

El propulsor final será el calculado con una velocidad de diseño de 11 nudos. A esta velocidad de diseño obtenemos un buen rendimiento y un valor de tiro que supera los 100 TPF de requisito.

Se obtiene el siguiente dimensionamiento:

To size			
Gear ratio:	Keep	1,00	
Expanded area ratio:	Size	0,558	
Propeller diameter:	Keep	4000,0	mm
Propeller mean pitch:	Keep	2200,0	mm
Design condition			
Design speed:		11,00	kt
Reference power:		4500,0	kW
Design point:		1,000	
Reference RPM:		220,0	
Design point:		1,000	
Max prop diam:		4000,0	mm
Review			
Tip speed:		46,08 !!	m/s

Los valores obtenidos del dimensionamiento en las condiciones de remolque y navegación libre para la velocidad de diseño escogida (11 nudos) se presentan en el ANEXO VI.

Analizando los resultados, el valor de tiro obtenido en KN para una velocidad de 0,1 nudos es de: Tracción final = 992,68 KN

Pasando ese valor a toneladas se obtiene: $TPF = \frac{992,68 \text{ KN}}{9,81 \text{ m/s}^2} = 101,20 \text{ Tn}$

Éste valor es suficiente para cumplir el requisito, por lo que el dimensionamiento del propulsor se considera válido.

A continuación y como cálculo complementario, se realizará una estimación teórica de la tracción que proporciona el propulsor azimutal retráctil de proa. Este thruster tendrá una potencia de 800 kW.

Para calcular el empuje de dicho thruster, se hace mención al libro ‘El proyecto básico del buque mercante’, de R. Alvariño, J.J. Azpíroz y M. Meizoso.

En él se proporciona un valor de empuje para hélices de túnel transversales de 11 kg/HP. Supondremos que el azimutal tendrá un empuje idéntico, por lo que el aumento en la tracción será de:

$$TPF \text{ thruster retráctil} = 800 \text{ KW} * \frac{1,341 \text{ HP}}{1 \text{ KW}} * \frac{11 \text{ Kg}}{1 \text{ HP}} * \frac{1 \text{ Tn}}{10^3 \text{ Kg}} = 11,80 \text{ Tn}$$

La tracción final del buque será de:

$$TPF \text{ final} = TPF_{AziPods} + TPF_{thruster} = 101,20 + 11,80 = 113 \text{ Tn}$$

A continuación se presenta la gráfica obtenida para el ensayo de tiro a punto fijo:

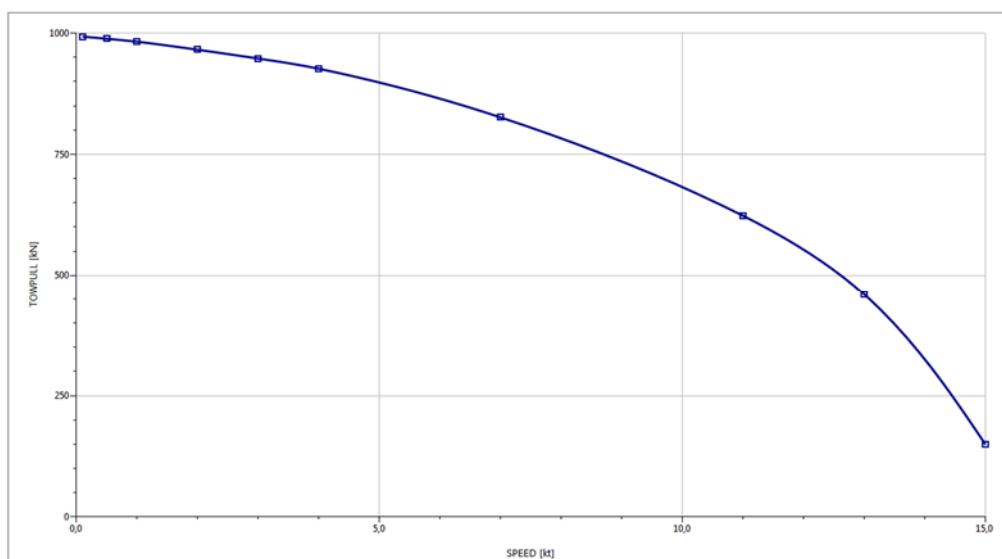

También se presenta la gráfica del rendimiento del propulsor final para la condición de navegación:

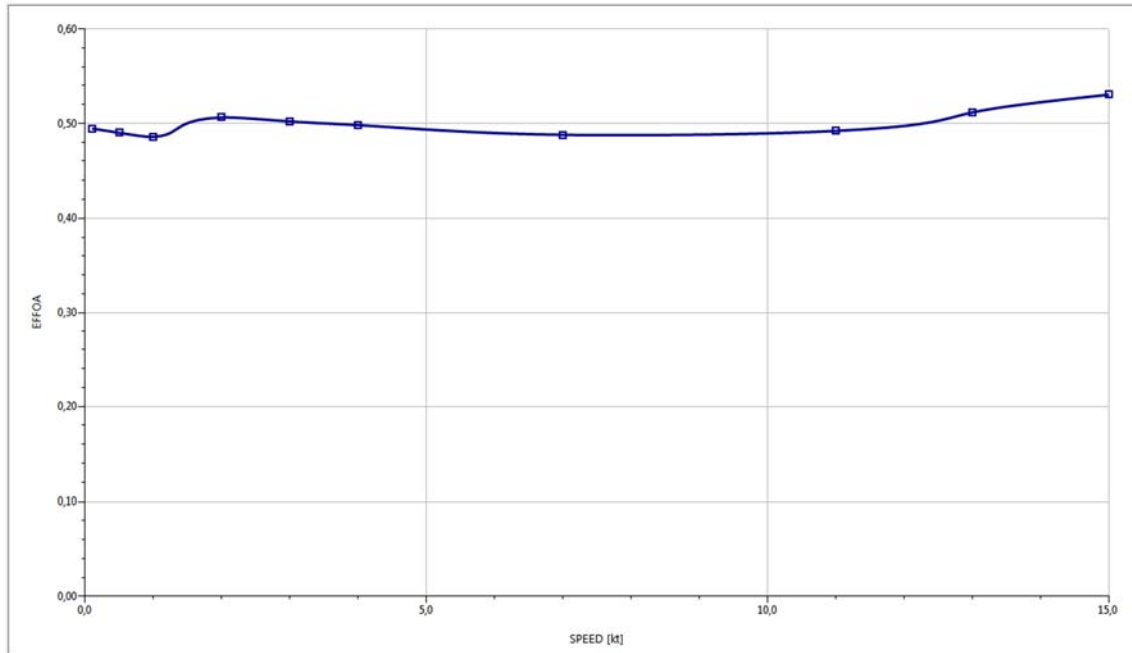

El propulsor dimensionado nos proporciona un valor de potencia al freno necesario para navegación en aguas libres de 6792 kW al 85% de MCR.

El valor total de BHP necesarios es: 7990,59 kW

Teniendo en cuenta la potencia de los propulsores AziPod seleccionados: 4,5 kW (2x), se comprueba que tienen potencia suficiente tanto para la navegación a 15 nudos como para el remolque con una restricción de 100 toneladas de tracción a punto fijo.

Se demuestra así que la planta propulsora planteada con el propulsor AziPod escogido cumple con los requisitos propuestos (RPA).

La potencia final instalada para la planta propulsora será de 9000 kW, frente a los 7520 kW obtenidos por dimensionamiento.

8. Características geométricas del propulsor

Relación área desarrollada /área de disco $AD/A_0 = 0,558$

Diámetro = 4,00 m

Relación paso diámetro $H/D = 0,55$

Inmersión de eje = 4,40 m

El propulsor cavitará un 2,0 % a la velocidad de diseño de 15 nudos en la condición de navegación libre.

A continuación se muestra unas imágenes 3D del propulsor dimensionado exportada del propio programa NavCad:

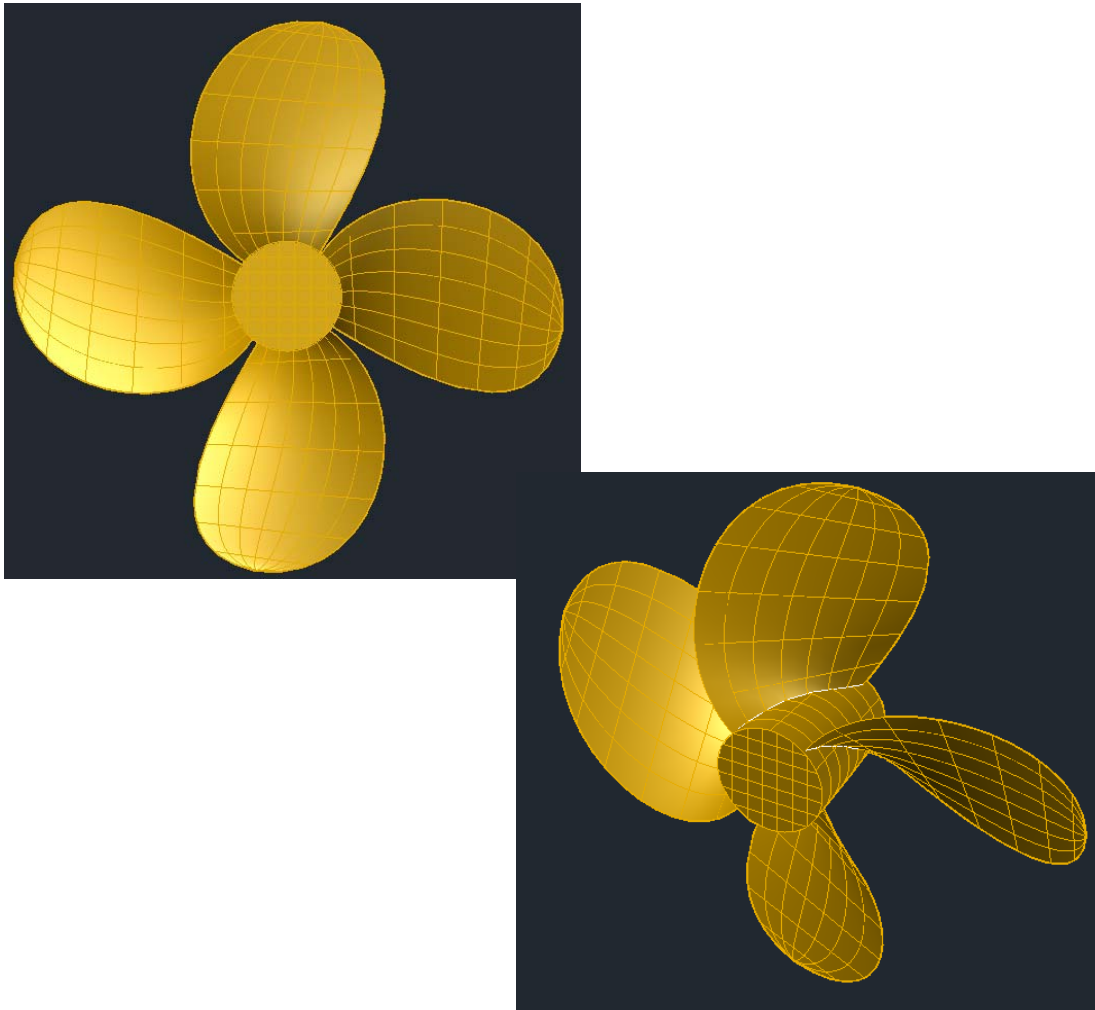

En el ANEXO VII se presentan los reports obtenidos con NavCad para el dimensionamiento del propulsor.

9. Cálculo del timón

Pese a tratarse de una propulsión AziPod, y no necesitar por tanto timones, se realizará un breve cálculo teórico.

Los timones son los aparatos de gobierno que dotan de maniobrabilidad al buque. Su función se sustituye al poder rotar 360° el propulsor AziPod.

Los timones elegidos para el cálculo serán de tipo suspendido y contorno regular.

ÁREA Y ALTURA

Se calculará el valor del área según el libro 'Proyecto básico del buque mercante':

Para buques con dos líneas de ejes (en este caso son dos propulsores), se considera el 1,25 % del área de deriva:

$$\text{Área de cada timón} = 1,25 \% * L_{pp} * T = \frac{1,25}{100} * 58,25 * 6,4 = 4,66 \text{ m}^2$$

La altura del timón tendrá un valor ligeramente superior al del diámetro del propulsor:

Diámetro propulsor = 4,00 m → Altura de cada timón = 4,20 m.

La longitud de cada timón se calcula como sigue:

$$\text{Longitud de cada timón} = \frac{\text{Área timón}}{\text{Altura timón}} = \frac{4,66}{4,20} = 1,10 \text{ m}$$

EJE DE GIRO DEL TIMÓN

Se supondrá un timón de tipo compensado.

En esta disposición, una parte de la pala se encuentra a proa del eje de giro. Una de las ventajas que ofrece es que reduce el esfuerzo necesario para mover el timón.

Sus características geométricas limitan el área situada por delante del eje, la cual debe estar entre el 10 y el 20% del área total del timón.

Se situará el eje a 0,30 m a popa del borde de proa del timón. Se comprueban a continuación las áreas:

$$\text{Área de compensación} = 0,20 \text{ m} * 4,20 \text{ m} = 0,84 \text{ m}^2$$

$$\text{Área compensada} / \text{Área total} = 0,84 / 4,66 = 0,1802 \rightarrow 18\%$$

10. Comprobación del Codaste

Recordando los márgenes mínimos del cuaderno 3:

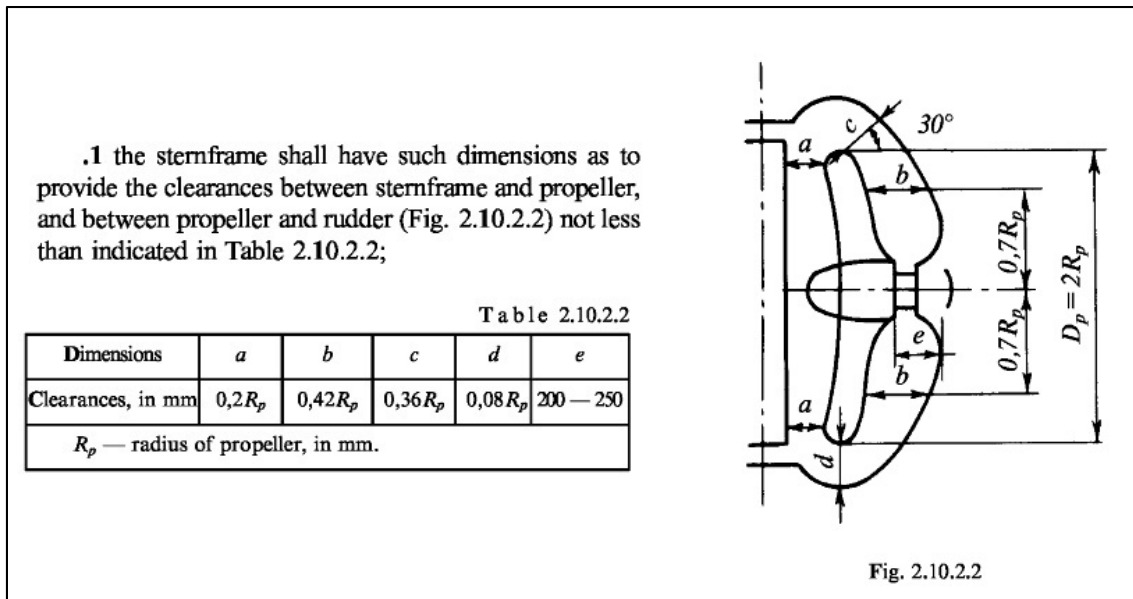

Valores mínimos ($R = 2000$ mm):

$$a = 400 \text{ mm}; b = 840 \text{ mm}; c = 720 \text{ mm}; d = 160 \text{ mm}; e = 250 \text{ mm}$$

Valores reales:

$$a = 3080 \text{ mm (orientado hacia popa)}; b = 2820 \text{ mm}; c = 1170 \text{ mm}.$$

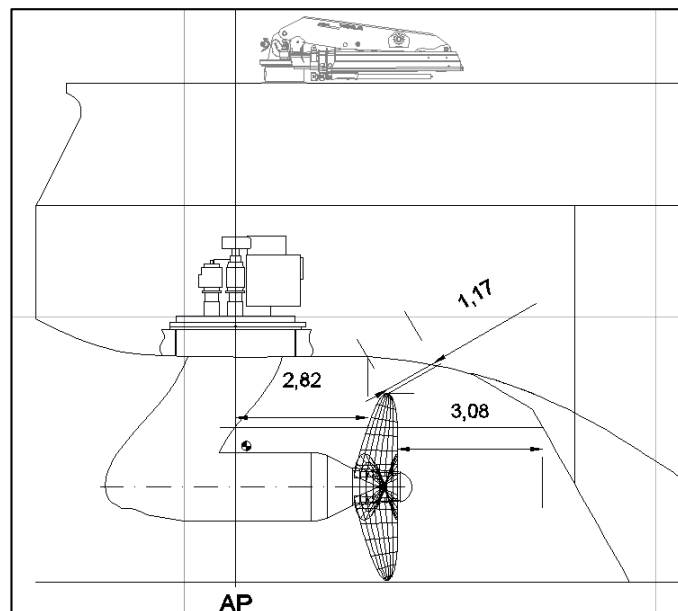

Se comprueba que el codaste cumple con los márgenes mínimos.

Los valores de 'd' y 'e' no tienen efecto en este tipo de propulsión, por lo que no se consideran.

En el ANEXO VIII se presenta el plano del codaste.



ANEXO I: Datos de Partida



Datos obtenidos con el programa MaxSurf Resistance

LWL	63,961	m
Beam	16,2	m
Draft	6,4	m
Displaced volume	4386,91	m ³
Wetted area	1469,226	m ²
Prismatic coeff. (Cp)	0,679	
Waterpl. area coeff. (Cwp)	0,909	
1/2 angle of entrance	32,8	deg.
LCG from midships(+ve for'd)	-0,529	m
Transom area	9,609	m ²
Transom wl beam	14,731	m
Transom draft	0,8	m
Max sectional area	100,99	m ²
Bulb transverse area	3,258	m ²
Bulb height from keel	6,013	m
Bulb nose fwd TR	57	m
Draft at FP	6,4	m
Deadrise at 50% LWL	0,5	deg.
Hard chine or Round bilge	Round bilge	
Frontal Area	0	m ²
Headwind	0	kn
Drag Coefficient	0	
Air density	0,001	tonne/m ³
Appendage Area	0	m ²
Nominal App. length	0	m
Appendage Factor	1	
Correlation allow.	0,0004	
Kinematic viscosity	1,1883E-06	m ² /s
Water Density	1,026	tonne/m ³



Hidrostáticas al calado de diseño (T=6,40 m)

Displacement	4495	t
Volume (displaced)	4384,991	m ³
Draft Amidships	6,4	m
Immersed depth	6,4	m
WL Length	63,961	m
Beam max extents on WL	16,2	m
Wetted Area	1537,013	m ²
Max sect. area	100,992	m ²
Waterpl. Area	942,466	m ²
Prismatic coeff. (Cp)	0,679	
Block coeff. (Cb)	0,661	
Max Sect. area coeff. (Cm)	0,978	
Waterpl. area coeff. (Cwp)	0,91	
LCB length	28,585	from zero pt. (+ve fwd) m
LCF length	25,482	from zero pt. (+ve fwd) m
LCB %	44,691	from zero pt. (+ve fwd) % Lwl
LCF %	39,84	from zero pt. (+ve fwd) % Lwl
KB	3,609	m
KG fluid	0	m
BMt	4,247	m
BML	64,242	m
GMt corrected	7,856	m
GML	67,851	m
KMt	7,856	m
KML	67,851	m
Immersion (TPc)	9,66	tonne/cm
MTc	52,354	tonne.m
RM at 1deg = GMt.Disp.sin(1)	616,265	tonne.m
Length:Beam ratio	3,948	
Beam:Draft ratio	2,531	
Length:Vol ^{0.333} ratio	3,908	
Precision	Highest	217 stations



ANEXO II:

Reports Resistencia al avance del buque

Resistance

14 may 2015 08:08

HydroComp NavCad 2014

Project ID Remolcador Rompehielos 100 TPF

Description

File name Predicción de Potencia.hcnc

Analysis parameters

Vessel drag		ITTC-78 (CT)		Added drag	
Technique:	[Calc] Prediction	Holtrop		Appendage:	[Calc] Percentage
Prediction:				Wind:	[Off]
Reference ship:				Seas:	[Off]
Model LWL:				Shallow/channel:	[Off]
Expansion:	Standard			Towed:	[Off]
Friction line:	ITTC-57			Margin:	[Calc] Hull + added drag [18%]
Hull form factor:	[On] 1,319			Water properties	
Speed corr:	[On]			Water type:	Salt
Spray drag corr:	[Off]			Density:	1026,00 kg/m3
Corr allowance:	ITTC-78 (v2008)			Viscosity:	1,18920e-6 m2/s
Roughness [mm]:	[On] 0,15				

Prediction method check [Holtrop]

Parameters	FN [design]	CP	LWL/BWL	BWL/T	Lambda
Value	0,31	0,68	3,95	2,53	0,86
Range	0,06-0,48	0,55-0,85	3,90-14,90	2,10-4,00	0,01-0,94

Prediction results

SPEED [kt]	SPEED COEFS		ITTC-78 COEFS						
	FN	FV	RN	CF	[CTLT/CF]	CR	dCF	CA	CT
0,10 !	0,002	0,004	2,77e6	0,003801	1,319	0,000197	0,000000	-0,000610	0,004601
2,00 !	0,041	0,081	5,53e7	0,002274	1,319	0,001294	0,000000	0,000589	0,004882
4,00	0,082	0,162	1,11e8	0,002053	1,319	0,001172	0,000000	0,000647	0,004527
6,00	0,123	0,244	1,66e8	0,001938	1,318	0,001052	0,000000	0,000657	0,004263
8,00	0,164	0,325	2,21e8	0,001863	1,314	0,000954	0,000000	0,000655	0,004056
10,00	0,205	0,406	2,77e8	0,001807	1,303	0,001098	0,000000	0,000649	0,004102
12,00	0,246	0,487	3,32e8	0,001764	1,283	0,001887	0,000000	0,000641	0,004791
14,00	0,288	0,569	3,87e8	0,001728	1,250	0,003855	0,000000	0,000633	0,006649
+ 15,00 +	0,308	0,609	4,15e8	0,001712	1,230	0,005660	0,000000	0,000629	0,008394
16,00	0,329	0,650	4,43e8	0,001698	1,208	0,006910	0,000000	0,000625	0,009585
RESISTANCE									
SPEED [kt]	RBARE [kN]	RAPP [kN]	RWIND [kN]	RSEAS [kN]	RCHAN [kN]	RTOWED [kN]	RMARGIN [kN]	RTOTAL [kN]	
0,10 !	0,01	0,00	0,00	0,00	0,00	0,00	0,00	0,01	
2,00 !	3,90	0,19	0,00	0,00	0,00	0,74	0,74	4,83	
4,00	14,45	0,72	0,00	0,00	0,00	2,73	2,73	17,90	
6,00	30,61	1,53	0,00	0,00	0,00	5,79	5,79	37,93	
8,00	51,78	2,59	0,00	0,00	0,00	9,79	9,79	64,16	
10,00	81,83	4,09	0,00	0,00	0,00	15,47	15,47	101,39	
12,00	137,61	6,88	0,00	0,00	0,00	26,01	26,01	170,50	
14,00	259,94	13,00	0,00	0,00	0,00	49,13	49,13	322,07	
+ 15,00 +	376,75	18,84	0,00	0,00	0,00	71,20	71,20	466,79	
16,00	489,44	24,47	0,00	0,00	0,00	92,50	92,50	606,42	
EFFECTIVE POWER									
SPEED [kt]	PEBARE [kW]	PETOTAL [kW]	CTLR	CTLT	RBARE/W				
0,10 !	0,0	0,0	0,00212	0,04935	0,00000				
2,00 !	4,0	5,0	0,01387	0,05236	0,00009				
4,00	29,7	36,8	0,01257	0,04855	0,00033				
6,00	94,5	117,1	0,01128	0,04572	0,00069				
8,00	213,1	264,1	0,01023	0,04350	0,00117				
10,00	421,0	521,6	0,01177	0,04400	0,00186				
12,00	849,5	1052,6	0,02024	0,05138	0,00312				
14,00	1872,2	2319,6	0,04135	0,07131	0,00590				
+ 15,00 +	2907,2	3602,0	0,06070	0,09003	0,00855				
16,00	4028,7	4991,5	0,07411	0,10279	0,01110				

Resistance

14 may 2015 08:08

HydroComp NavCad 2014

Project ID Remolcador Rompehielos 100 TPF

Description

File name Predicción de Potencia.hcnc

Hull data

General		Planing	
Configuration:	Monohull	<i>Proj chine length:</i>	0,000 m
Chine type:	Round/multiple	<i>Proj bottom area:</i>	0,0 m2
Length on WL:	63,961 m	<i>LCG fwd TR:</i>	[XCG/LP 0,000] 0,000 m
Max beam on WL:	[LWL/BWL 3,948] 16,200 m	<i>VCG below WL:</i>	0,000 m
Max molded draft:	[BWL/T 2,531] 6,400 m	<i>Aft station (fwd TR):</i>	0,000 m
Displacement:	[CB 0,661] 4495,00 t	<i>Deadrise:</i>	0,00 deg
Wetted surface:	[CS 2,775] 1469,2 m2	<i>Chine beam:</i>	0,000 m
ITTC-78 (CT)		<i>Chine ht below WL:</i>	0,000 m
LCB fwd TR:	[XCB/LWL 0,513] 32,825 m	<i>Fwd station (fwd TR):</i>	0,000 m
LCF fwd TR:	[XCF/LWL 0,465] 29,722 m	<i>Deadrise:</i>	0,00 deg
Max section area:	[CX 0,974] 101,0 m2	<i>Chine beam:</i>	0,000 m
Waterplane area:	[CWP 0,910] 942,5 m2	<i>Chine ht below WL:</i>	0,000 m
Bulb section area:	3,3 m2	<i>Propulsor type:</i>	Propeller
Bulb ctr below WL:	6,013 m	<i>Max prop diameter:</i>	4000,0 mm
Bulb nose fwd TR:	57,000 m	<i>Shaft angle to WL:</i>	0,00 deg
Imm transom area:	[ATR/AX 0,095] 9,6 m2	<i>Position fwd TR:</i>	0,000 m
Transom beam WL:	[BTR/BWL 0,909] 14,731 m	<i>Position below WL:</i>	0,000 m
Transom immersion:	[TTR/T 0,125] 0,800 m	<i>Transom lift device:</i>	Flap
Half entrance angle:	32,80 deg	<i>Device count:</i>	0
Bow shape factor:	[AVG flow] 0,0	<i>Span:</i>	0,000 m
Stern shape factor:	[AVG flow] 0,0	<i>Chord length:</i>	0,000 m
		<i>Deflection angle:</i>	0,00 deg
		<i>Tow point fwd TR:</i>	0,000 m
		<i>Tow point below WL:</i>	0,000 m

Resistance

14 may 2015 08:08

HydroComp NavCad 2014

Project ID Remolcador Rompehielos 100 TPF

Description

File name Predicción de Potencia.hcnc

Appendage data

General		Skeg/Keel	
Definition:	Percentage	Count:	0
Percent of hull drag:	5,00 %	Type:	Skeg
Planing influence		Mean length:	0,000 m
LCE fwd TR:	0,000 m	Mean width:	0,000 m
VCE below WL:	0,000 m	Height aft:	0,000 m
Shafting		Height mid:	0,000 m
Count:	2	Height fwd:	0,000 m
Max prop diameter:	4000,0 mm	Projected area:	0,0 m2
Shaft angle to WL:	0,00 deg	Wetted surface:	0,0 m2
Exposed shaft length:	0,000 m	Stabilizer	
Shaft diameter:	0,000 m	Count:	0
Wetted surface:	0,0 m2	Root chord:	0,000 m
Strut bossing length:	0,000 m	Tip chord:	0,000 m
Bossing diameter:	0,000 m	Span:	0,000 m
Wetted surface:	0,0 m2	T/C ratio:	0,000
Hull bossing length:	0,000 m	LE sweep:	0,00 deg
Bossing diameter:	0,000 m	Wetted surface:	0,0 m2
Wetted surface:	0,0 m2	Projected area:	0,0 m2
Strut (per shaft line)		Dynamic multiplier:	1,00
Count:	0	Bilge keel	
Root chord:	0,000 m	Count:	0
Tip chord:	0,000 mm	Mean length:	0,000 m
Span:	0,000 m	Mean base width:	0,000 m
T/C ratio:	0,000	Mean projection:	0,000 m
Projected area:	0,0 m2	Wetted surface:	0,0 m2
Wetted surface:	0,0 m2	Tunnel thruster	
Exposed palm depth:	0,000 m	Count:	0
Exposed palm width:	0,000 m	Diameter:	0,000 m
Rudder		Sonar dome	
Count:	0	Count:	0
Rudder location:	Behind propeller	Wetted surface:	0,0 m2
Type:	Balanced foil	Miscellaneous	
Root chord:	0,000 m	Count:	0
Tip chord:	0,000 m	Drag area:	0,0 m2
Span:	0,000 m	Drag coef:	0,00
T/C ratio:	0,000		
LE sweep:	0,00 deg		
Projected area:	0,0 m2		
Wetted surface:	0,0 m2		

Environment data

Wind		Seas	
Wind speed:	0,00 kt	Significant wave ht:	0,000 m
Angle off bow:	0,00 deg	Modal wave period:	0,0 sec
Gradient correction:	Off	Shallow/channel	
Exposed hull		Water depth:	0,000 m
Transverse area:	0,0 m2	Type:	Shallow water
VCE above WL:	0,000 m	Channel width:	0,000 m
Profile area:	0,0 m2	Channel side slope:	0,00 deg
Superstructure		Hull girth:	0,000 m
Superstructure shape:	Cargo ship		
Transverse area:	0,0 m2		
VCE above WL:	0,000 m		
Profile area:	0,0 m2		

Resistance

14 may 2015 08:08

HydroComp NavCad 2014

Project ID

Remolcador Rompehielos 100 TPF

Description

File name

Predicción de Potencia.hcnc

Symbols and values

SPEED = Vessel speed
FN = Froude number [LWL]
FV = Froude number [VOL]
RN = Reynolds number [LWL]
CF = Frictional resistance coefficient
CV/CF = Viscous/frictional resistance coefficient ratio [dynamic form factor]
CR = Residuary resistance coefficient
dCF = Added frictional resistance coefficient for roughness
CA = Correlation allowance [dynamic]
CT = Total bare-hull resistance coefficient
RBARE = Bare-hull resistance
RAPP = Additional appendage resistance
RWIND = Additional wind resistance
RSEAS = Additional sea-state resistance
RCHAN = Additional shallow/channel resistance
RTOWED = Additional towed object resistance
RMARGIN = Resistance margin
RTOTAL = Total vessel resistance
PEBARE = Bare-hull effective power
PETOTAL = Total effective power
CTLR = Telfer residuary resistance coefficient
CTLT = Telfer total bare-hull resistance coefficient
RBARE/W = Bare-hull resistance to weight ratio
+ = Design speed indicator
* = Exceeds parameter limit



ANEXO III:

Información Propulsor AziPod

3 Azipod® product platforms

The three available Azipod product platforms are briefly described below.

3.1 Azipod C series

This product platform was developed with the experiences gained from the classic family of larger Azipod products.

The Azipod CO variant (optimized for open water operation) is available in three different frame sizes for propeller power ratings of up to 4.5 MW.

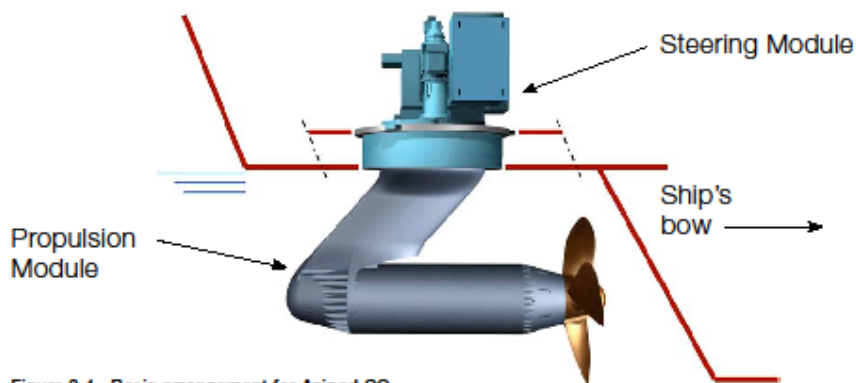

Figure 3-1 Basic arrangement for Azipod CO

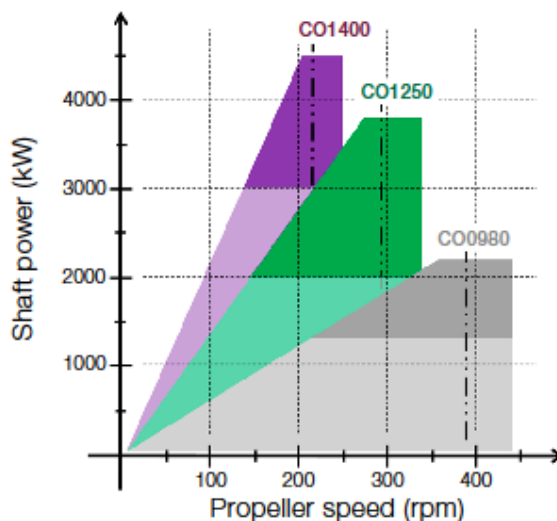

Figure 3-2 Azipod CO power output vs. propeller RPM

B Azipod® Product Platform Selection Guide



ANEXO IV: Reports Navegación Libre

Propulsion

14 may 2015 09:34

HydroComp NavCad 2014

Project ID Remolcador Rompehielos 100 TPF

Description

File name Predicción de Potencia.hcnc

Analysis parameters

Hull-propulsor interaction		System analysis	
Technique:	[Calc] Prediction	Cavitation criteria:	Keller eqn
Prediction:	Holtrop	Analysis type:	Free run
Reference ship:		CPP method:	
Max prop diam:	4000,0 mm	Engine RPM:	
Corrections		Mass multiplier:	
Viscous scale corr:	[On] Standard	RPM constraint:	
Rudder location:	Behind propeller	Limit [RPM/s]:	
Friction line:	ITTC-57	Water properties	
Hull form factor:	1,319	Water type:	Salt
Corr allowance:	ITTC-78 (v2008)	Density:	1026,00 kg/m3
Roughness [mm]:	[Off] 0,15	Viscosity:	1,18920e-6 m2/s
Ducted prop corr:	[Off]		
Tunnel stern corr:	[Off]		
Effective diam:			
Recess depth:			

Prediction method check [Holtrop]

Parameters	FN [design]	CP	LWL/BWL	BWL/T
Value	0,31	0,68	3,95	2,53
Range	0,06-0,80	0,55-0,85	3,90-14,90	2,10-4,00

Prediction results [System]

SPEED [kt]	HULL-PROPULSOR				ENGINE			
	PETOTAL [kW]	WFT	THD	EFFR	RPMENG [RPM]	PBPROP [kW]	FUEL [L/h]	LOADENG [%]
0,10 !	0,0	0,1361	0,1407	1,0109	1	0,0	---	0,0
0,50 !	0,1	0,1361	0,1407	1,0109	6	0,1	---	0,0
1,00 !	0,5	0,1361	0,1407	1,0109	12	0,4	---	0,0
2,00 !	5,0	0,1361	0,1407	1,0109	25	3,8	---	0,1
3,00	16,1	0,1355	0,1407	1,0109	38	12,4	---	0,3
4,00	36,8	0,1348	0,1407	1,0109	50	28,3	---	0,6
7,00	180,8	0,1334	0,1407	1,0109	86	138,5	---	3,1
11,00	734,5	0,1324	0,1407	1,0109	136	564,0	---	12,5
13,00	1513,9	0,1321	0,1407	1,0109	170	1179,1	---	26,2
+ 15,00 +	3602,0	0,1318	0,1407	1,0109	220	2963,6	---	65,9
POWER DELIVERY								
SPEED [kt]	RPMPROP [RPM]	QPROP [kN·m]	QENG [kN·m]	PDPROP [kW]	PSPROP [kW]	PSTOTAL [kW]	PBTOTAL [kW]	TRANSP
0,10 !	1	0,00	0,00	0,0	0,0	0,0	0,0	---
0,50 !	6	0,08	0,08	0,1	0,1	0,1	0,1	---
1,00 !	12	0,31	0,31	0,4	0,4	0,8	0,8	---
2,00 !	25	1,45	1,45	3,8	3,8	7,6	7,6	---
3,00	38	3,16	3,16	12,4	12,4	24,7	24,7	---
4,00	50	5,46	5,46	28,3	28,3	56,5	56,5	---
7,00	86	15,58	15,58	138,5	138,5	276,9	276,9	573,2
11,00	136	39,95	39,95	564,0	564,0	1128,0	1128,0	221,1
13,00	170	67,09	67,09	1179,1	1179,1	2358,1	2358,1	125,0
+ 15,00 +	220	130,04	130,04	2963,6	2963,6	5927,3	5927,3	57,4
EFFICIENCY				THRUST				
SPEED [kt]	EFFO	EFFG	EFFOA	MERIT	THRPROP [kN]	DELTHR [kN]		
0,10 !	0,6497	1,0000	0,6533	0,38315	0,01	0,01		
0,50 !	0,6512	1,0000	0,6548	0,37293	0,15	0,26		
1,00 !	0,6518	1,0000	0,6554	0,36646	0,57	0,99		
2,00 !	0,6460	1,0000	0,6496	0,4015	2,81	4,83		
3,00	0,6477	1,0000	0,6509	0,39407	6,06	10,42		
4,00	0,6489	1,0000	0,6515	0,38778	10,41	17,90		
7,00	0,6513	1,0000	0,6529	0,37186	29,21	50,20		
11,00	0,6503	1,0000	0,6511	0,37948	75,52	129,79		
13,00	0,6414	1,0000	0,6420	0,41811	131,71	226,37		
+ 15,00 +	0,6074	1,0000	0,6077	0,49255	271,60	466,79		

Propulsion

14 may 2015 09:34

HydroComp NavCad 2014

Project ID Remolcador Rompehielos 100 TPF

Description

File name Predicción de Potencia.hcnc

Prediction results [Propulsor]

SPEED [kt]	PROPULSOR COEFS								
	J	KT	KQ	KTJ2	KQJ3	CTH	CP	RNPROP	
0,10 !	0,6367	0,1107	0,01727	0,27312	0,066903	0,6955	1,0589	1,25e5	
0,50 !	0,6449	0,1071	0,01689	0,25761	0,062965	0,65601	0,99659	6,16e5	
1,00 !	0,6501	0,1049	0,01665	0,24824	0,060612	0,63214	0,95935	1,22e6	
2,00 !	0,6216	0,1172	0,01795	0,30336	0,074737	0,7725	1,1829	2,55e6	
3,00	0,6277	0,1146	0,01767	0,29074	0,071442	0,74036	1,1308	3,79e6	
4,00	0,6329	0,1123	0,01744	0,28045	0,068782	0,71416	1,0887	5,03e6	
7,00	0,6458	0,1068	0,01685	0,25604	0,062569	0,65201	0,99032	8,64e6	
11,00	0,6396	0,1094	0,01713	0,26745	0,065456	0,68105	1,036	1,37e7	
13,00	0,6076	0,1232	0,01857	0,33371	0,082801	0,84978	1,3105	1,70e7	
+ 15,00 +	0,5408	0,1510	0,02140	0,51652	0,13535	1,3153	2,1423	2,19e7	
SPEED [kt]	CAVITATION								
	SIGMAV	SIGMAN	SIGMA07R	TIPSPEED [m/s]	MINBAR	PRESS [kPa]	CAVAVG [%]	CAVMAX [%]	PITCHFC [mm]
0,10 !	142017,18	57567,51	10983,10	0,22	0,058	0,00	2,0	2,0	2476,3
0,50 !	5680,69	2362,70	449,87	1,08	0,057	0,03	2,0	2,0	2491,7
1,00 !	1420,17	600,17	114,13	2,15	0,058	0,13	2,0	2,0	2501,4
2,00 !	355,04	137,17	26,27	4,49	0,063	0,66	2,0	2,0	2448,3
3,00	157,58	62,09	11,87	6,68	0,067	1,42	2,0	2,0	2459,6
4,00	88,48	35,44	6,77	8,84	0,074	2,43	2,0	2,0	2469,2
7,00	28,80	12,01	2,29	15,18	0,101	6,83	2,0	2,0	2493,3
11,00	11,64	4,76	0,91	24,11	0,172	17,65	2,0	2,0	2481,8
13,00	8,33	3,07	0,59	30,01	0,260	30,78	2,0	2,0	2422,5
+ 15,00 +	6,25	1,83	0,36	38,92	0,477	63,47 !!	6,6	6,6	2303,8

Propulsion

14 may 2015 09:34

HydroComp NavCad 2014

Project ID Remolcador Rompehielos 100 TPF

Description

File name Predicción de Potencia.hcnc

Hull data

General		Planing	
Configuration:	Monohull	Proj chine length:	0,000 m
Chine type:	Round/multiple	Proj bottom area:	0,0 m2
Length on WL:	63,961 m	LCG fwd TR:	[XCG/LP 0,000] 0,000 m
Max beam on WL:	[LWL/BWL 3,948] 16,200 m	VCG below WL:	0,000 m
Max molded draft:	[BWL/T 2,531] 6,400 m	Aft station (fwd TR):	0,000 m
Displacement:	[CB 0,661] 4495,00 t	Deadrise:	0,00 deg
Wetted surface:	[CS 2,775] 1469,2 m2	Chine beam:	0,000 m
ITTC-78 (CT)		Chine ht below WL:	0,000 m
LCB fwd TR:	[XCB/LWL 0,513] 32,825 m	Fwd station (fwd TR):	0,000 m
LCF fwd TR:	[XCF/LWL 0,465] 29,722 m	Deadrise:	0,00 deg
Max section area:	[CX 0,974] 101,0 m2	Chine beam:	0,000 m
Waterplane area:	[CWP 0,910] 942,5 m2	Chine ht below WL:	0,000 m
Bulb section area:	3,3 m2	Propulsor type:	Propeller
Bulb ctr below WL:	6,013 m	Max prop diameter:	4000,0 mm
Bulb nose fwd TR:	57,000 m	Shaft angle to WL:	0,00 deg
Imm transom area:	[ATR/AX 0,095] 9,6 m2	Position fwd TR:	0,000 m
Transom beam WL:	[BTR/BWL 0,909] 14,731 m	Position below WL:	0,000 m
Transom immersion:	[TTR/T 0,125] 0,800 m	Transom lift device:	Flap
Half entrance angle:	32,80 deg	Device count:	0
Bow shape factor:	[AVG flow] 0,0	Span:	0,000 m
Stern shape factor:	[AVG flow] 0,0	Chord length:	0,000 m
		Deflection angle:	0,00 deg
		Tow point fwd TR:	0,000 m
		Tow point below WL:	0,000 m

Propulsor data

Propulsor		Propeller options	
Count:	2	Oblique angle corr:	Off
Propulsor type:	Propeller series	Shaft angle to WL:	0,00 deg
Propeller type:	FPP	Added rise of run:	0,00 deg
Propeller series:	B Series	Propeller cup:	0,0 mm
Propeller sizing:	By thrust	KTKQ corrections:	Custom
Reference prop:		Scale correction:	None
Blade count:	4	KT multiplier:	1,000
Expanded area ratio:	0,4772 [Size]	KQ multiplier:	1,000
Propeller diameter:	3379,0 mm [Size]	Blade T/C [0.7R]:	0,00
Propeller mean pitch:	[P/D 0,7900] 2669,6 mm [Size]	Roughness:	0,00 mm
Hub immersion:	4400,0 mm	Cav breakdown:	Off
Engine/gear		Design condition	
Engine data:	AziPod CO1400	Max prop diam:	4000,0 mm
Rated RPM:	220 RPM	Design speed:	15,00 kt
Rated power:	4500,0 kW	Reference power:	4500,0 kW
Gear efficiency:	1,000	Design point:	1,000
Load correction:	Off	Reference RPM:	220,0
Gear ratio:	1,000 [Keep]	Design point:	1,000
Shaft efficiency:	1,000		

Propulsion

14 may 2015 09:34

HydroComp NavCad 2014

Project ID Remolcador Rompehielos 100 TPF

Description

File name Predicción de Potencia.hcnc

Symbols and values

SPEED = Vessel speed

PETOTAL = Total vessel effective power
WFT = Taylor wake fraction coefficient
THD = Thrust deduction coefficient
EFFR = Relative-rotative efficiency

RPMENG = Engine RPM
PBPROP = Brake power per propulsor
FUEL = Fuel rate per engine
LOADENG = Percentage of engine max available power at given RPM

RPMPROP = Propulsor RPM
QPROP = Propulsor open water torque
QENG = Engine torque
PDPROP = Delivered power per propulsor
PSPROP = Shaft power per propulsor
PSTOTAL = Total vessel shaft power
PBTOTAL = Total vessel brake power
TRANSP = Transport factor

EFFO = Propulsor open-water efficiency
EFFG = Gear efficiency (load corrected)
EFFOA = Overall propulsion efficiency [=PETOTAL/PSTOTAL]
MERIT = Propulsor merit coefficient

THRPROP = Open-water thrust per propulsor
DELTHR = Total vessel delivered thrust

J = Propulsor advance coefficient
KT = Propulsor thrust coefficient [horizontal, if in oblique flow]
KQ = Propulsor torque coefficient
KTJ2 = Propulsor thrust loading ratio
KQJ3 = Propulsor torque loading ratio
CTH = Horizontal component of bare-hull resistance coefficient
CP = Propulsor thrust loading coefficient
RNPROP = Propeller Reynolds number at 0.7R

SIGMAV = Cavitation number of propeller by vessel speed
SIGMAN = Cavitation number of propeller by RPM
SIGMA07R = Cavitation number of blade section at 0.7R
TIPSPEED = Propeller circumferential tip speed
MINBAR = Minimum expanded blade area ratio recommended by selected cavitation criteria
PRESS = Average propeller loading pressure
CAVAVG = Average predicted back cavitation percentage
CAVMAX = Peak predicted back cavitation percentage [if in oblique flow]
PITCHFC = Minimum recommended pitch to avoid face cavitation

+ = Design speed indicator
* = Exceeds recommended parameter limit
! = Exceeds recommended cavitation criteria [warning]
!! = Substantially exceeds recommended cavitation criteria [critical]
!!! = Thrust breakdown is indicated [severe]
--- = Insignificant or not applicable

Propulsion

14 may 2015 09:36

HydroComp NavCad 2014

Project ID Remolcador Rompehielos 100 TPF

Description

File name Predicción de Potencia.hcnc

Analysis parameters

Hull-propulsor interaction		System analysis	
Technique:	[Calc] Prediction	Cavitation criteria:	Keller eqn
Prediction:	Holtrop	Analysis type:	Free run
Reference ship:		CPP method:	
Max prop diam:	4000,0 mm	Engine RPM:	
Corrections		Mass multiplier:	
Viscous scale corr:	[On] Standard	RPM constraint:	
Rudder location:	Behind propeller	Limit [RPM/s]:	
Friction line:	ITTC-57	Water properties	
Hull form factor:	1,319	Water type:	Salt
Corr allowance:	ITTC-78 (v2008)	Density:	1026,00 kg/m3
Roughness [mm]:	[Off] 0,15	Viscosity:	1,18920e-6 m2/s
Ducted prop corr:	[Off]		
Tunnel stern corr:	[Off]		
Effective diam:			
Recess depth:			

Prediction method check [Holtrop]

Parameters	FN [design]	CP	LWL/BWL	BWL/T
Value	0,31	0,68	3,95	2,53
Range	0,06-0,80	0,55-0,85	3,90-14,90	2,10-4,00

Prediction results [System]

SPEED [kt]	HULL-PROPULSOR				ENGINE			
	PETOTAL [kW]	WFT	THD	EFFR	RPMENG [RPM]	PBPROP [kW]	FUEL [L/h]	LOADENG [%]
0,10 !	0,0	0,1361	0,1407	0,9957	1	0,0	---	0,0
0,50 !	0,1	0,1361	0,1407	0,9957	6	0,1	---	0,0
1,00 !	0,5	0,1361	0,1407	0,9957	12	0,4	---	0,0
2,00 !	5,0	0,1361	0,1407	0,9957	25	3,9	---	0,1
3,00	16,1	0,1355	0,1407	0,9957	38	12,6	---	0,3
4,00	36,8	0,1348	0,1407	0,9957	50	28,9	---	0,6
7,00	180,8	0,1334	0,1407	0,9957	86	141,3	---	3,1
11,00	734,5	0,1324	0,1407	0,9957	136	575,8	---	12,8
13,00	1513,9	0,1321	0,1407	0,9957	169	1208,1	---	26,8
+ 15,00 +	3602,0	0,1318	0,1407	0,9957	220	3054,8	---	67,9
POWER DELIVERY								
SPEED [kt]	RPMPROP [RPM]	QPROP [kN·m]	QENG [kN·m]	PDPROP [kW]	PSPROP [kW]	PSTOTAL [kW]	PBTOTAL [kW]	TRANSP
0,10 !	1	0,00	0,00	0,0	0,0	0,0	0,0	---
0,50 !	6	0,08	0,08	0,1	0,1	0,1	0,1	---
1,00 !	12	0,31	0,31	0,4	0,4	0,8	0,8	---
2,00 !	25	1,47	1,47	3,9	3,9	7,8	7,8	---
3,00	38	3,19	3,19	12,6	12,6	25,3	25,3	---
4,00	50	5,51	5,51	28,9	28,9	57,8	57,8	---
7,00	86	15,69	15,69	141,3	141,3	282,5	282,5	561,9
11,00	136	40,26	40,26	575,8	575,8	1151,6	1151,6	216,6
13,00	169	67,82	67,82	1208,1	1208,1	2416,1	2416,1	122,0
+ 15,00 +	220	132,03	132,03	3054,8	3054,8	6109,6	6109,6	55,7
EFFICIENCY				THRUST				
SPEED [kt]	EFFO	EFFG	EFFOA	MERIT	THRPROP [kN]	DELTHR [kN]		
0,10 !	0,6457	1,0000	0,6395	0,39878	0,01	0,01		
0,50 !	0,6480	1,0000	0,6418	0,38761	0,15	0,26		
1,00 !	0,6490	1,0000	0,6428	0,38116	0,57	0,99		
2,00 !	0,6411	1,0000	0,6350	0,41613	2,81	4,83		
3,00	0,6432	1,0000	0,6366	0,40872	6,06	10,42		
4,00	0,6448	1,0000	0,6376	0,40242	10,41	17,90		
7,00	0,6481	1,0000	0,6400	0,38651	29,21	50,20		
11,00	0,6467	1,0000	0,6378	0,39413	75,52	129,79		
13,00	0,6356	1,0000	0,6266	0,4327	131,71	226,37		
+ 15,00 +	0,5982	1,0000	0,5896	0,50669	271,60	466,79		

Propulsion

14 may 2015 09:36

HydroComp NavCad 2014

Project ID Remolcador Rompehielos 100 TPF

Description

File name Predicción de Potencia.hcnc

Prediction results [Propulsor]

SPEED [kt]	PROPULSOR COEFS								
	J	KT	KQ	KTJ2	KQJ3	CTH	CP	RNPROP	
0,10 !	0,6656	0,1327	0,02178	0,2996	0,073852	0,76294	1,1867	1,09e5	
0,50 !	0,6752	0,1281	0,02125	0,28106	0,069036	0,71571	1,1093	5,38e5	
1,00 !	0,6806	0,1255	0,02094	0,27087	0,066423	0,68977	1,0673	1,07e6	
2,00 !	0,6504	0,1400	0,02260	0,33092	0,082153	0,84267	1,3201	2,23e6	
3,00	0,6569	0,1369	0,02225	0,31715	0,078477	0,80761	1,261	3,31e6	
4,00	0,6624	0,1342	0,02195	0,30592	0,07551	0,77902	1,2134	4,39e6	
7,00	0,6761	0,1277	0,02120	0,27929	0,068582	0,71122	1,102	7,54e6	
11,00	0,6696	0,1308	0,02156	0,29174	0,071801	0,74291	1,1538	1,20e7	
13,00	0,6355	0,1470	0,02340	0,36401	0,091152	0,92695	1,4647	1,49e7	
+ 15,00 +	0,5648	0,1797	0,02700	0,56343	0,1499	1,4348	2,4087	1,92e7	
SPEED [kt]	CAVITATION								
	SIGMAV	SIGMAN	SIGMA07R	TIPSPEED [m/s]	MINBAR	PRESS [kPa]	CAVAVG [%]	CAVMAX [%]	PITCHFC [mm]
0,10 !	142017,18	62916,02	11917,89	0,21	0,056	0,00	2,0	2,0	2506,3
0,50 !	5680,69	2589,57	489,34	1,03	0,055	0,03	2,0	2,0	2522,8
1,00 !	1420,17	657,90	124,15	2,05	0,056	0,12	2,0	2,0	2532,2
2,00 !	355,04	150,19	28,56	4,29	0,062	0,60	2,0	2,0	2480,3
3,00	157,58	68,01	12,91	6,38	0,067	1,30	2,0	2,0	2491,5
4,00	88,48	38,83	7,36	8,44	0,075	2,23	2,0	2,0	2500,9
7,00	28,80	13,17	2,49	14,50	0,109	6,26	2,0	2,0	2524,4
11,00	11,64	5,22	0,99	23,03	0,196	16,19	2,0	2,0	2513,2
13,00	8,33	3,36	0,64	28,69	0,302	28,24	2,0	2,0	2455,2
+ 15,00 +	6,25	1,99	0,39	37,27	0,567	58,24 !	5,8	5,8	2339,2

Propulsion

14 may 2015 09:36

HydroComp NavCad 2014

Project ID **Remolcador Rompehielos 100 TPF**

Description

File name **Predicción de Potencia.hcnc**

Hull data

General		Planing	
Configuration:	Monohull	Proj chine length:	0,000 m
Chine type:	Round/multiple	Proj bottom area:	0,0 m2
Length on WL:	63,961 m	LCG fwd TR:	[XCG/LP 0,000] 0,000 m
Max beam on WL:	[LWL/BWL 3,948] 16,200 m	VCG below WL:	0,000 m
Max molded draft:	[BWL/T 2,531] 6,400 m	Aft station (fwd TR):	0,000 m
Displacement:	[CB 0,661] 4495,00 t	Deadrise:	0,00 deg
Wetted surface:	[CS 2,775] 1469,2 m2	Chine beam:	0,000 m
ITTC-78 (CT)		Chine ht below WL:	0,000 m
LCB fwd TR:	[XCB/LWL 0,513] 32,825 m	Fwd station (fwd TR):	0,000 m
LCF fwd TR:	[XCF/LWL 0,465] 29,722 m	Deadrise:	0,00 deg
Max section area:	[CX 0,974] 101,0 m2	Chine beam:	0,000 m
Waterplane area:	[CWP 0,910] 942,5 m2	Chine ht below WL:	0,000 m
Bulb section area:	3,3 m2	Propulsor type:	Propeller
Bulb ctr below WL:	6,013 m	Max prop diameter:	4000,0 mm
Bulb nose fwd TR:	57,000 m	Shaft angle to WL:	0,00 deg
Imm transom area:	[ATR/AX 0,095] 9,6 m2	Position fwd TR:	0,000 m
Transom beam WL:	[BTR/BWL 0,909] 14,731 m	Position below WL:	0,000 m
Transom immersion:	[TTR/T 0,125] 0,800 m	Transom lift device:	Flap
Half entrance angle:	32,80 deg	Device count:	0
Bow shape factor:	[AVG flow] 0,0	Span:	0,000 m
Stern shape factor:	[AVG flow] 0,0	Chord length:	0,000 m
		Deflection angle:	0,00 deg
		Tow point fwd TR:	0,000 m
		Tow point below WL:	0,000 m

Propulsor data

Propulsor		Propeller options	
Count:	2	Oblique angle corr:	Off
Propulsor type:	Propeller series	Shaft angle to WL:	0,00 deg
Propeller type:	FPP	Added rise of run:	0,00 deg
Propeller series:	B Series	Propeller cup:	0,0 mm
Propeller sizing:	By thrust	KTKQ corrections:	Custom
Reference prop:		Scale correction:	None
Blade count:	5	KT multiplier:	1,000
Expanded area ratio:	0,5672 [Size]	KQ multiplier:	1,000
Propeller diameter:	3235,3 mm [Size]	Blade T/C [0.7R]:	0,00
Propeller mean pitch:	[P/D 0,8530] 2759,6 mm [Size]	Roughness:	0,00 mm
Hub immersion:	4400,0 mm	Cav breakdown:	Off
Engine/gear		Design condition	
Engine data:	AziPod CO1400	Max prop diam:	4000,0 mm
Rated RPM:	220 RPM	Design speed:	15,00 kt
Rated power:	4500,0 kW	Reference power:	4500,0 kW
Gear efficiency:	1,000	Design point:	1,000
Load correction:	Off	Reference RPM:	220,0
Gear ratio:	1,000 [Keep]	Design point:	1,000
Shaft efficiency:	1,000		

Propulsion

14 may 2015 09:36

HydroComp NavCad 2014

Project ID Remolcador Rompehielos 100 TPF

Description

File name Predicción de Potencia.hcnc

Symbols and values

SPEED = Vessel speed

PETOTAL = Total vessel effective power
WFT = Taylor wake fraction coefficient
THD = Thrust deduction coefficient
EFFR = Relative-rotative efficiency

RPMENG = Engine RPM
PBPROP = Brake power per propulsor
FUEL = Fuel rate per engine
LOADENG = Percentage of engine max available power at given RPM

RPMPROP = Propulsor RPM
QPROP = Propulsor open water torque
QENG = Engine torque
PDPROP = Delivered power per propulsor
PSPROP = Shaft power per propulsor
PSTOTAL = Total vessel shaft power
PBTOTAL = Total vessel brake power
TRANSP = Transport factor

EFFO = Propulsor open-water efficiency
EFFG = Gear efficiency (load corrected)
EFFOA = Overall propulsion efficiency [=PETOTAL/PSTOTAL]
MERIT = Propulsor merit coefficient

THRPROP = Open-water thrust per propulsor
DELTHR = Total vessel delivered thrust

J = Propulsor advance coefficient
KT = Propulsor thrust coefficient [horizontal, if in oblique flow]
KQ = Propulsor torque coefficient
KTJ2 = Propulsor thrust loading ratio
KQJ3 = Propulsor torque loading ratio
CTH = Horizontal component of bare-hull resistance coefficient
CP = Propulsor thrust loading coefficient
RNPROP = Propeller Reynolds number at 0.7R

SIGMAV = Cavitation number of propeller by vessel speed
SIGMAN = Cavitation number of propeller by RPM
SIGMA07R = Cavitation number of blade section at 0.7R
TIPSPEED = Propeller circumferential tip speed
MINBAR = Minimum expanded blade area ratio recommended by selected cavitation criteria
PRESS = Average propeller loading pressure
CAVAVG = Average predicted back cavitation percentage
CAVMAX = Peak predicted back cavitation percentage [if in oblique flow]
PITCHFC = Minimum recommended pitch to avoid face cavitation

+ = Design speed indicator
* = Exceeds recommended parameter limit
! = Exceeds recommended cavitation criteria [warning]
!! = Substantially exceeds recommended cavitation criteria [critical]
!!! = Thrust breakdown is indicated [severe]
--- = Insignificant or not applicable

Propulsion

14 may 2015 09:38

HydroComp NavCad 2014

Project ID Remolcador Rompehielos 100 TPF

Description

File name Predicción de Potencia.hcnc

Analysis parameters

Hull-propulsor interaction		System analysis	
Technique:	[Calc] Prediction	Cavitation criteria:	Keller eqn
Prediction:	Holtrop	Analysis type:	Free run
Reference ship:		CPP method:	
Max prop diam:	4000,0 mm	Engine RPM:	
Corrections		Mass multiplier:	
Viscous scale corr:	[On] Standard	RPM constraint:	
Rudder location:	Behind propeller	Limit [RPM/s]:	
Friction line:	ITTC-57	Water properties	
Hull form factor:	1,319	Water type:	Salt
Corr allowance:	ITTC-78 (v2008)	Density:	1026,00 kg/m3
Roughness [mm]:	[Off] 0,15	Viscosity:	1,18920e-6 m2/s
Ducted prop corr:	[Off]		
Tunnel stern corr:	[Off]		
Effective diam:			
Recess depth:			

Prediction method check [Holtrop]

Parameters	FN [design]	CP	LWL/BWL	BWL/T
Value	0,31	0,68	3,95	2,53
Range	0,06-0,80	0,55-0,85	3,90-14,90	2,10-4,00

Prediction results [System]

SPEED [kt]	HULL-PROPULSOR				ENGINE			
	PETOTAL [kW]	WFT	THD	EFFR	RPMENG [RPM]	PBPROP [kW]	FUEL [L/h]	LOADENG [%]
0,10 !	0,0	0,1361	0,1407	0,9917	1	0,0	---	0,0
0,50 !	0,1	0,1361	0,1407	0,9917	6	0,1	---	0,0
1,00 !	0,5	0,1361	0,1407	0,9917	12	0,4	---	0,0
2,00 !	5,0	0,1361	0,1407	0,9917	25	4,0	---	0,1
3,00	16,1	0,1355	0,1407	0,9917	38	12,8	---	0,3
4,00	36,8	0,1348	0,1407	0,9917	50	29,2	---	0,6
7,00	180,8	0,1334	0,1407	0,9917	85	142,9	---	3,2
11,00	734,5	0,1324	0,1407	0,9917	136	582,7	---	12,9
13,00	1513,9	0,1321	0,1407	0,9917	169	1224,4	---	27,2
+ 15,00 +	3602,0	0,1318	0,1407	0,9917	220	3106,5	---	69,0
POWER DELIVERY								
SPEED [kt]	RPMPROP [RPM]	QPROP [kN·m]	QENG [kN·m]	PDPROP [kW]	PSPROP [kW]	PSTOTAL [kW]	PBTOTAL [kW]	TRANSP
0,10 !	1	0,00	0,00	0,0	0,0	0,0	0,0	---
0,50 !	6	0,08	0,08	0,1	0,1	0,1	0,1	---
1,00 !	12	0,31	0,31	0,4	0,4	0,8	0,8	---
2,00 !	25	1,48	1,48	4,0	4,0	7,9	7,9	---
3,00	38	3,22	3,22	12,8	12,8	25,6	25,6	---
4,00	50	5,56	5,56	29,2	29,2	58,5	58,5	---
7,00	85	15,83	15,83	142,9	142,9	285,8	285,8	555,5
11,00	136	40,63	40,63	582,7	582,7	1165,3	1165,3	214,1
13,00	169	68,51	68,51	1224,4	1224,4	2448,8	2448,8	120,4
+ 15,00 +	220	133,73	133,73	3106,5	3106,5	6213,0	6213,0	54,7
EFFICIENCY				THRUST				
SPEED [kt]	EFFO	EFFG	EFFOA	MERIT	THRPROP [kN]	DELTHR [kN]		
0,10 !	0,6404	1,0000	0,6317	0,41027	0,01	0,01		
0,50 !	0,6431	1,0000	0,6344	0,39838	0,15	0,26		
1,00 !	0,6443	1,0000	0,6356	0,39187	0,57	0,99		
2,00 !	0,6355	1,0000	0,6269	0,42717	2,81	4,83		
3,00	0,6378	1,0000	0,6288	0,41969	6,06	10,42		
4,00	0,6396	1,0000	0,6299	0,41334	10,41	17,90		
7,00	0,6433	1,0000	0,6326	0,39725	29,21	50,20		
11,00	0,6416	1,0000	0,6303	0,40496	75,52	129,79		
13,00	0,6296	1,0000	0,6182	0,44387	131,71	226,37		
+ 15,00 +	0,5906	1,0000	0,5798	0,51803	271,60	466,79		

Propulsion

14 may 2015 09:38

HydroComp NavCad 2014

Project ID Remolcador Rompehielos 100 TPF

Description

File name Predicción de Potencia.hcnc

Prediction results [Propulsor]

SPEED [kt]	PROPULSOR COEFS								
	J	KT	KQ	KTJ2	KQJ3	CTH	CP	RNPROP	
0,10 !	0,6895	0,1533	0,02627	0,32238	0,080125	0,82094	1,2927	9,88e4	
0,50 !	0,7000	0,1477	0,02559	0,30141	0,074597	0,76754	1,2035	4,87e5	
1,00 !	0,7057	0,1447	0,02522	0,29052	0,071763	0,7398	1,1578	9,68e5	
2,00 !	0,6742	0,1613	0,02723	0,35485	0,088867	0,90362	1,4337	2,02e6	
3,00	0,6810	0,1577	0,02680	0,34008	0,084863	0,86602	1,3691	3,00e6	
4,00	0,6868	0,1547	0,02644	0,32804	0,081633	0,83536	1,317	3,97e6	
7,00	0,7010	0,1472	0,02553	0,29949	0,074095	0,76265	1,1954	6,84e6	
11,00	0,6942	0,1508	0,02596	0,31284	0,077597	0,79664	1,2519	1,09e7	
13,00	0,6587	0,1694	0,02820	0,39034	0,098669	0,99399	1,5919	1,35e7	
+ 15,00 +	0,5848	0,2067	0,03257	0,60417	0,1628	1,5385	2,6266	1,74e7	
SPEED [kt]	CAVITATION								
	SIGMAV	SIGMAN	SIGMA07R	TIPSPEED [m/s]	MINBAR	PRESS [kPa]	CAVAVG [%]	CAVMAX [%]	PITCHFC [mm]
0,10 !	142017,18	67517,79	12711,56	0,20	0,054	0,00	2,0	2,0	2530,6
0,50 !	5680,69	2783,82	522,67	1,00	0,054	0,03	2,0	2,0	2547,4
1,00 !	1420,17	707,31	132,60	1,98	0,054	0,11	2,0	2,0	2556,6
2,00 !	355,04	161,38	30,50	4,14	0,061	0,55	2,0	2,0	2506,3
3,00	157,58	73,08	13,79	6,15	0,068	1,20	2,0	2,0	2517,1
4,00	88,48	41,73	7,86	8,14	0,077	2,06	2,0	2,0	2526,2
7,00	28,80	14,15	2,66	13,99	0,118	5,77	2,0	2,0	2549,0
11,00	11,64	5,61	1,05	22,22	0,220	14,92	2,0	2,0	2538,1
13,00	8,33	3,61	0,69	27,68	0,347	26,01	2,0	2,0	2481,9
+ 15,00 +	6,25	2,14	0,41	35,99	0,660	53,64 !	5,0	5,0	2369,2

Propulsion

14 may 2015 09:38

HydroComp NavCad 2014

Project ID **Remolcador Rompehielos 100 TPF**

Description

File name **Predicción de Potencia.hcnc**

Hull data

General		Planing	
Configuration:	Monohull	Proj chine length:	0,000 m
Chine type:	Round/multiple	Proj bottom area:	0,0 m2
Length on WL:	63,961 m	LCG fwd TR:	[XCG/LP 0,000] 0,000 m
Max beam on WL:	[LWL/BWL 3,948] 16,200 m	VCG below WL:	0,000 m
Max molded draft:	[BWL/T 2,531] 6,400 m	Aft station (fwd TR):	0,000 m
Displacement:	[CB 0,661] 4495,00 t	Deadrise:	0,00 deg
Wetted surface:	[CS 2,775] 1469,2 m2	Chine beam:	0,000 m
ITTC-78 (CT)		Chine ht below WL:	0,000 m
LCB fwd TR:	[XCB/LWL 0,513] 32,825 m	Fwd station (fwd TR):	0,000 m
LCF fwd TR:	[XCF/LWL 0,465] 29,722 m	Deadrise:	0,00 deg
Max section area:	[CX 0,974] 101,0 m2	Chine beam:	0,000 m
Waterplane area:	[CWP 0,910] 942,5 m2	Chine ht below WL:	0,000 m
Bulb section area:	3,3 m2	Propulsor type:	Propeller
Bulb ctr below WL:	6,013 m	Max prop diameter:	4000,0 mm
Bulb nose fwd TR:	57,000 m	Shaft angle to WL:	0,00 deg
Imm transom area:	[ATR/AX 0,095] 9,6 m2	Position fwd TR:	0,000 m
Transom beam WL:	[BTR/BWL 0,909] 14,731 m	Position below WL:	0,000 m
Transom immersion:	[TTR/T 0,125] 0,800 m	Transom lift device:	Flap
Half entrance angle:	32,80 deg	Device count:	0
Bow shape factor:	[AVG flow] 0,0	Span:	0,000 m
Stern shape factor:	[AVG flow] 0,0	Chord length:	0,000 m
		Deflection angle:	0,00 deg
		Tow point fwd TR:	0,000 m
		Tow point below WL:	0,000 m

Propulsor data

Propulsor		Propeller options	
Count:	2	Oblique angle corr:	Off
Propulsor type:	Propeller series	Shaft angle to WL:	0,00 deg
Propeller type:	FPP	Added rise of run:	0,00 deg
Propeller series:	B Series	Propeller cup:	0,0 mm
Propeller sizing:	By thrust	KTKQ corrections:	Custom
Reference prop:		Scale correction:	None
Blade count:	6	KT multiplier:	1,000
Expanded area ratio:	0,6604 [Size]	KQ multiplier:	1,000
Propeller diameter:	3124,3 mm [Size]	Blade T/C [0.7R]:	0,00
Propeller mean pitch:	[P/D 0,9075] 2835,1 mm [Size]	Roughness:	0,00 mm
Hub immersion:	4400,0 mm	Cav breakdown:	Off
Engine/gear		Design condition	
Engine data:	AziPod CO1400	Max prop diam:	4000,0 mm
Rated RPM:	220 RPM	Design speed:	15,00 kt
Rated power:	4500,0 kW	Reference power:	4500,0 kW
Gear efficiency:	1,000	Design point:	1,000
Load correction:	Off	Reference RPM:	220,0
Gear ratio:	1,000 [Keep]	Design point:	1,000
Shaft efficiency:	1,000		

Propulsion

14 may 2015 09:38

HydroComp NavCad 2014

Project ID Remolcador Rompehielos 100 TPF

Description

File name Predicción de Potencia.hcnc

Symbols and values

SPEED = Vessel speed

PETOTAL = Total vessel effective power
WFT = Taylor wake fraction coefficient
THD = Thrust deduction coefficient
EFFR = Relative-rotative efficiency

RPMENG = Engine RPM
PBPROP = Brake power per propulsor
FUEL = Fuel rate per engine
LOADENG = Percentage of engine max available power at given RPM

RPMPROP = Propulsor RPM
QPROP = Propulsor open water torque
QENG = Engine torque
PDPROP = Delivered power per propulsor
PSPROP = Shaft power per propulsor
PSTOTAL = Total vessel shaft power
PBTOTAL = Total vessel brake power
TRANSP = Transport factor

EFFO = Propulsor open-water efficiency
EFFG = Gear efficiency (load corrected)
EFFOA = Overall propulsion efficiency [=PETOTAL/PSTOTAL]
MERIT = Propulsor merit coefficient

THRPROP = Open-water thrust per propulsor
DELTHR = Total vessel delivered thrust

J = Propulsor advance coefficient
KT = Propulsor thrust coefficient [horizontal, if in oblique flow]
KQ = Propulsor torque coefficient
KTJ2 = Propulsor thrust loading ratio
KQJ3 = Propulsor torque loading ratio
CTH = Horizontal component of bare-hull resistance coefficient
CP = Propulsor thrust loading coefficient
RNPROP = Propeller Reynolds number at 0.7R

SIGMAV = Cavitation number of propeller by vessel speed
SIGMAN = Cavitation number of propeller by RPM
SIGMA07R = Cavitation number of blade section at 0.7R
TIPSPEED = Propeller circumferential tip speed
MINBAR = Minimum expanded blade area ratio recommended by selected cavitation criteria
PRESS = Average propeller loading pressure
CAVAVG = Average predicted back cavitation percentage
CAVMAX = Peak predicted back cavitation percentage [if in oblique flow]
PITCHFC = Minimum recommended pitch to avoid face cavitation

+ = Design speed indicator
* = Exceeds recommended parameter limit
! = Exceeds recommended cavitation criteria [warning]
!! = Substantially exceeds recommended cavitation criteria [critical]
!!! = Thrust breakdown is indicated [severe]
--- = Insignificant or not applicable



ANEXO V: Report Predicción a Remolque

Propulsion

14 may 2015 08:35

HydroComp NavCad 2014

Project ID Remolcador Rompehielos 100 TPF

Description

File name Predicción de Potencia.hcnc

Analysis parameters

Hull-propulsor interaction		System analysis	
Technique:	[Calc] Prediction	Cavitation criteria:	Keller eqn
Prediction:	Holtrop	Analysis type:	Towing
Reference ship:		CPP method:	
Max prop diam:	4000,0 mm	Engine RPM:	
Corrections		Mass multiplier:	
Viscous scale corr:	[On] Standard	RPM constraint:	
Rudder location:	Behind propeller	Limit [RPM/s]:	
Friction line:	ITTC-57	Water properties	
Hull form factor:	1,319	Water type:	Salt
Corr allowance:	ITTC-78 (v2008)	Density:	1026,00 kg/m3
Roughness [mm]:	[Off] 0,15	Viscosity:	1,18920e-6 m2/s
Ducted prop corr:	[Off]		
Tunnel stern corr:	[Off]		
Effective diam:			
Recess depth:			

Prediction method check [Holtrop]

Parameters	FN [design]	CP	LWL/BWL	BWL/T
Value	0,31	0,68	3,95	2,53
Range	0,06-0,80	0,55-0,85	3,90-14,90	2,10-4,00

Prediction results [System]

SPEED [kt]	HULL-PROPULSOR				ENGINE			
	PETOTAL [kW]	WFT	THD	EFFR	RPMENG [RPM]	PBPROP [kW]	FUEL [L/h]	LOADENG [%]
0,10 !	0,0	0,1361	0,1407	0,9883	208	4498,9	---	100,0
0,50 !	5,0	0,1361	0,1407	0,9883	209	4498,7	---	100,0
1,00 !	36,8	0,1361	0,1407	0,9883	209	4498,5	---	100,0
2,00 !	117,1	0,1361	0,1407	0,9883	211	4498,2	---	100,0
3,00	264,1	0,1355	0,1407	0,9883	213	4497,9	---	100,0
4,00	521,6	0,1348	0,1407	0,9883	215	4497,7	---	99,9
7,00	1052,6	0,1334	0,1407	0,9883	221	4497,7	---	99,9
11,00	2319,6	0,1324	0,1407	0,9883	231	4498,8	---	100,0
13,00	3602,0	0,1321	0,1407	0,9883	237	4499,5	---	100,0
+ 15,00 +	4991,5	0,1318	0,1407	0,9883	243	4497,1	---	99,9
POWER DELIVERY								
SPEED [kt]	RPMPROP [RPM]	QPROP [kN·m]	QENG [kN·m]	PDPROP [kW]	PSPROP [kW]	PSTOTAL [kW]	PBTOTAL [kW]	TRANSP
0,10 !	208	204,11	204,11	4498,9	4498,9	8997,8	8997,8	0,0
0,50 !	209	203,52	203,52	4498,7	4498,7	8997,4	8997,4	0,0
1,00 !	209	202,75	202,75	4498,5	4498,5	8997,0	8997,0	0,0
2,00 !	211	201,18	201,18	4498,2	4498,2	8996,3	8996,3	0,0
3,00	213	199,54	199,54	4497,9	4497,9	8995,8	8995,8	0,0
4,00	215	197,82	197,82	4497,7	4497,7	8995,4	8995,4	0,0
7,00	221	192,25	192,25	4497,7	4497,7	8995,4	8995,4	0,0
11,00	231	183,86	183,86	4498,8	4498,8	8997,6	8997,6	0,0
13,00	237	179,28	179,28	4499,5	4499,5	8999,0	8999,0	0,0
+ 15,00 +	243	174,40	174,40	4497,1	4497,1	8994,3	8994,3	0,0
EFFICIENCY				THRUST				
SPEED [kt]	EFFO	EFFG	EFFOA	MERIT	THRPROP [kN]	DELTHR [kN]	TOWPULL [kN]	
0,10 !	0,0052	1,0000	0,0051	0,88459	522,10	897,33	897,32	
0,50 !	0,0260	1,0000	0,0255	0,87837	519,64	893,09	888,26	
1,00 !	0,0516	1,0000	0,0507	0,87021	516,40	887,53	869,62	
2,00 !	0,1019	1,0000	0,1001	0,85272	509,43	875,55	837,62	
3,00	0,1506	1,0000	0,1480	0,83376	501,83	862,49	798,33	
4,00	0,1977	1,0000	0,1941	0,81349	493,65	848,42	747,03	
7,00	0,3273	1,0000	0,3207	0,74643	466,14	801,14	630,63	
11,00	0,4684	1,0000	0,4585	0,64784	424,20	729,06	406,99	
13,00	0,5243	1,0000	0,5130	0,59683	401,66	690,33	223,54	
+ 15,00 +	0,5702	1,0000	0,5577	0,54566	378,24	650,06	43,64	

Propulsion

14 may 2015 08:35

HydroComp NavCad 2014

Project ID **Remolcador Rompehielos 100 TPF**
 Description
 File name **Predicción de Potencia.hcnc**

Prediction results [Propulsor]

SPEED [kt]	PROPULSOR COEFS								
	J	KT	KQ	KTJ2	KQJ3	CTH	CP	RNPROP	
0,10 !	0,0038	0,3248	0,03758	22565	688150	57461	11141000	2,02e7	
0,50 !	0,0189	0,3214	0,03725	898,34	5505	2287,6	89124	2,03e7	
1,00 !	0,0377	0,3170	0,03684	223,18	688,09	568,33	11140	2,03e7	
2,00 !	0,0748	0,3080	0,03599	55,043	86,005	140,17	1392,4	2,05e7	
3,00	0,1114	0,2985	0,03512	24,066	25,43	61,284	411,7	2,07e7	
4,00	0,1473	0,2886	0,03423	13,293	10,699	33,85	173,22	2,09e7	
7,00	0,2510	0,2574	0,03141	4,0858	1,987	10,404	32,169	2,16e7	
11,00	0,3775	0,2141	0,02746	1,5023	0,51043	3,8256	8,2638	2,27e7	
13,00	0,4352	0,1927	0,02546	1,0177	0,30892	2,5915	5,0012	2,34e7	
+ 15,00 +	0,4889	0,1719	0,02346	0,71933	0,20079	1,8317	3,2507	2,41e7	
SPEED [kt]	CAVITATION								
	SIGMAV	SIGMAN	SIGMA07R	TIPSPEED [m/s]	MINBAR	PRESS [kPa]	CAVAVG [%]	CAVMAX [%]	PITCHFC [mm]
0,10 !	142017,18	2,04	0,42	36,80 !	0,894	122,00 !!	40,3 !!	40,3	1542,9
0,50 !	5680,69	2,03	0,42	36,91 !!	0,889	121,43 !!	39,7 !!	39,7	1560,7
1,00 !	1420,17	2,02	0,42	37,05 !!	0,883	120,67 !!	38,9 !!	38,9	1583,0
2,00 !	355,04	1,99	0,41	37,33 !!	0,870	119,04 !!	37,2 !!	37,2	1627,8
3,00	157,58	1,95	0,40	37,64 !!	0,856	117,27 !!	35,5 !!	35,5	1673,0
4,00	88,48	1,92	0,40	37,96 !!	0,841	115,36 !!	33,7 !!	33,7	1718,5
7,00	28,80	1,81	0,37	39,06 !!	0,793	108,93 !!	28,1 !!	28,1	1856,0
11,00	11,64	1,66	0,33	40,86 !!	0,720	99,13 !!	20,9 !	20,9	2038,9
13,00	8,33	1,58	0,31	41,90 !!	0,682	93,86 !!	17,6	17,6	2128,5
+ 15,00 +	6,25	1,49	0,29	43,06 !!	0,643	88,39 !!	14,6	14,6	2215,8

Propulsion

14 may 2015 08:35

HydroComp NavCad 2014

Project ID Remolcador Rompehielos 100 TPF

Description

File name Predicción de Potencia.hcnc

Hull data

General		Planing	
Configuration:	Monohull	Proj chine length:	0,000 m
Chine type:	Round/multiple	Proj bottom area:	0,0 m2
Length on WL:	63,961 m	LCG fwd TR:	[XCG/LP 0,000] 0,000 m
Max beam on WL:	[LWL/BWL 3,948] 16,200 m	VCG below WL:	0,000 m
Max molded draft:	[BWL/T 2,531] 6,400 m	Aft station (fwd TR):	0,000 m
Displacement:	[CB 0,661] 4495,00 t	Deadrise:	0,00 deg
Wetted surface:	[CS 2,775] 1469,2 m2	Chine beam:	0,000 m
ITTC-78 (CT)		Chine ht below WL:	0,000 m
LCB fwd TR:	[XCB/LWL 0,513] 32,825 m	Fwd station (fwd TR):	0,000 m
LCF fwd TR:	[XCF/LWL 0,465] 29,722 m	Deadrise:	0,00 deg
Max section area:	[CX 0,974] 101,0 m2	Chine beam:	0,000 m
Waterplane area:	[CWP 0,910] 942,5 m2	Chine ht below WL:	0,000 m
Bulb section area:	3,3 m2	Propulsor type:	Propeller
Bulb ctr below WL:	6,013 m	Max prop diameter:	4000,0 mm
Bulb nose fwd TR:	57,000 m	Shaft angle to WL:	0,00 deg
Imm transom area:	[ATR/AX 0,095] 9,6 m2	Position fwd TR:	0,000 m
Transom beam WL:	[BTR/BWL 0,909] 14,731 m	Position below WL:	0,000 m
Transom immersion:	[TTR/T 0,125] 0,800 m	Transom lift device:	Flap
Half entrance angle:	32,80 deg	Device count:	0
Bow shape factor:	[AVG flow] 0,0	Span:	0,000 m
Stern shape factor:	[AVG flow] 0,0	Chord length:	0,000 m
		Deflection angle:	0,00 deg
		Tow point fwd TR:	0,000 m
		Tow point below WL:	0,000 m

Propulsor data

Propulsor		Propeller options	
Count:	2	Oblique angle corr:	Off
Propulsor type:	Propeller series	Shaft angle to WL:	0,00 deg
Propeller type:	FPP	Added rise of run:	0,00 deg
Propeller series:	B Series	Propeller cup:	0,0 mm
Propeller sizing:	By thrust	KTKQ corrections:	Custom
Reference prop:		Scale correction:	None
Blade count:	4	KT multiplier:	1,000
Expanded area ratio:	0,4772 [Size]	KQ multiplier:	1,000
Propeller diameter:	3379,0 mm [Size]	Blade T/C [0.7R]:	0,00
Propeller mean pitch:	[P/D 0,7900] 2669,6 mm [Size]	Roughness:	0,00 mm
Hub immersion:	4400,0 mm	Cav breakdown:	Off
Engine/gear		Design condition	
Engine data:	AziPod CO1400	Max prop diam:	4000,0 mm
Rated RPM:	220 RPM	Design speed:	15,00 kt
Rated power:	4500,0 kW	Reference power:	4500,0 kW
Gear efficiency:	1,000	Design point:	1,000
Load correction:	Off	Reference RPM:	220,0
Gear ratio:	1,000 [Keep]	Design point:	1,000
Shaft efficiency:	1,000		

Symbols and values

SPEED = Vessel speed

PETOTAL = Total vessel effective power
WFT = Taylor wake fraction coefficient
THD = Thrust deduction coefficient
EFFR = Relative-rotative efficiency

RPMENG = Engine RPM
PBPROP = Brake power per propulsor
FUEL = Fuel rate per engine
LOADENG = Percentage of engine max available power at given RPM

RPMPROP = Propulsor RPM
QPROP = Propulsor open water torque
QENG = Engine torque
PDPROP = Delivered power per propulsor
PSPROP = Shaft power per propulsor
PSTOTAL = Total vessel shaft power
PBTOTAL = Total vessel brake power
TRANSP = Transport factor

EFFO = Propulsor open-water efficiency
EFFG = Gear efficiency (load corrected)
EFFOA = Overall propulsion efficiency [=PETOTAL/PSTOTAL]
MERIT = Propulsor merit coefficient

THRPROP = Open-water thrust per propulsor
DELTHR = Total vessel delivered thrust

J = Propulsor advance coefficient
KT = Propulsor thrust coefficient [horizontal, if in oblique flow]
KQ = Propulsor torque coefficient
KTJ2 = Propulsor thrust loading ratio
KQJ3 = Propulsor torque loading ratio
CTH = Horizontal component of bare-hull resistance coefficient
CP = Propulsor thrust loading coefficient
RNPROP = Propeller Reynolds number at 0.7R

SIGMAV = Cavitation number of propeller by vessel speed
SIGMAN = Cavitation number of propeller by RPM
SIGMA07R = Cavitation number of blade section at 0.7R
TIPSPEED = Propeller circumferential tip speed
MINBAR = Minimum expanded blade area ratio recommended by selected cavitation criteria
PRESS = Average propeller loading pressure
CAVAVG = Average predicted back cavitation percentage
CAVMAX = Peak predicted back cavitation percentage [if in oblique flow]
PITCHFC = Minimum recommended pitch to avoid face cavitation

+ = Design speed indicator
* = Exceeds recommended parameter limit
! = Exceeds recommended cavitation criteria [warning]
!! = Substantially exceeds recommended cavitation criteria [critical]
!!! = Thrust breakdown is indicated [severe]
--- = Insignificant or not applicable



ANEXO VI:

Reports

Dimensionamiento del Propulsor

Propulsion

14 may 2015 09:03

HydroComp NavCad 2014

Project ID Remolcador Rompehielos 100 TPF

Description

File name Predicción de Potencia.hcnc

Analysis parameters

Hull-propulsor interaction		System analysis	
Technique:	[Calc] Prediction	Cavitation criteria:	Keller eqn
Prediction:	Holtrop	Analysis type:	Towing
Reference ship:		CPP method:	
Max prop diam:	4000,0 mm	Engine RPM:	
Corrections		Mass multiplier:	
Viscous scale corr:	[On] Standard	RPM constraint:	
Rudder location:	Behind propeller	Limit [RPM/s]:	
Friction line:	ITTC-57	Water properties	
Hull form factor:	1,319	Water type:	Salt
Corr allowance:	ITTC-78 (v2008)	Density:	1026,00 kg/m3
Roughness [mm]:	[Off] 0,15	Viscosity:	1,18920e-6 m2/s
Ducted prop corr:	[Off]		
Tunnel stern corr:	[Off]		
Effective diam:			
Recess depth:			

Prediction method check [Holtrop]

Parameters	FN [design]	CP	LWL/BWL	BWL/T
Value	0,23	0,68	3,95	2,53
Range	0,06-0,80	0,55-0,85	3,90-14,90	2,10-4,00

Prediction results [System]

SPEED [kt]	HULL-PROPULSOR				ENGINE			
	PETOTAL [kW]	WFT	THD	EFFR	RPMENG [RPM]	PBPROP [kW]	FUEL [L/h]	LOADENG [%]
0,10 !	0,0	0,1361	0,1407	1,0109	188	4166,3	---	92,6
0,50 !	0,1	0,1361	0,1407	1,0109	189	4188,7	---	93,1
1,00 !	0,5	0,1361	0,1407	1,0109	191	4217,6	---	93,7
2,00 !	5,0	0,1361	0,1407	1,0109	194	4272,6	---	94,9
3,00	16,1	0,1355	0,1407	1,0109	197	4339,2	---	96,4
4,00	36,8	0,1348	0,1407	1,0109	201	4410,2	---	98,0
7,00	180,8	0,1334	0,1407	1,0109	210	4497,8	---	100,0
+ 11,00 +	734,5	0,1324	0,1407	1,0109	223	4497,2	---	99,9
13,00	1513,9	0,1321	0,1407	1,0109	231	4498,4	---	100,0
15,00	3602,0	0,1318	0,1407	1,0109	240	4499,6	---	100,0
SPEED [kt]	POWER DELIVERY							
	RPMPROP [RPM]	QPROP [kN.m]	QENG [kN.m]	PDPROP [kW]	PSPROP [kW]	PSTOTAL [kW]	PBTOTAL [kW]	TRANSP
0,10 !	188	213,54	213,54	4166,3	4166,3	8332,6	8332,6	0,0
0,50 !	189	213,42	213,42	4188,7	4188,7	8377,4	8377,4	0,0
1,00 !	191	213,27	213,27	4217,6	4217,6	8435,2	8435,2	0,0
2,00 !	194	212,77	212,77	4272,6	4272,6	8545,2	8545,2	0,0
3,00	197	212,52	212,52	4339,2	4339,2	8678,5	8678,5	0,0
4,00	201	212,26	212,26	4410,2	4410,2	8820,3	8820,3	0,0
7,00	210	206,69	206,69	4497,8	4497,8	8995,6	8995,6	0,0
+ 11,00 +	223	194,29	194,29	4497,2	4497,2	8994,4	8994,4	0,0
13,00	231	187,79	187,79	4498,4	4498,4	8996,8	8996,8	0,0
15,00	240	181,17	181,17	4499,6	4499,6	8999,2	8999,2	0,0
SPEED [kt]	EFFICIENCY				THRUST			
	EFFO	EFFG	EFFOA	MERIT	THRPROP [kN]	DELTHR [kN]	TOWPULL [kN]	
0,10 !	0,0061	1,0000	0,0061	0,91788	577,58	992,68	992,67	
0,50 !	0,0302	1,0000	0,0304	0,90725	575,17	988,52	988,27	
1,00 !	0,0596	1,0000	0,0600	0,89359	571,99	983,07	982,08	
2,00 !	0,1162	1,0000	0,1168	0,86513	564,64	970,43	965,60	
3,00	0,1695	1,0000	0,1703	0,83536	557,33	957,87	947,45	
4,00	0,2194	1,0000	0,2203	0,8045	549,43	944,29	926,39	
7,00	0,3500	1,0000	0,3508	0,70519	509,87	876,30	826,10	
+ 11,00 +	0,4732	1,0000	0,4738	0,56185	438,16	753,05	623,26	
13,00	0,5097	1,0000	0,5101	0,48868	399,31	686,28	459,91	
15,00	0,5283	1,0000	0,5286	0,41588	358,66	616,43	149,64	

Propulsion

14 may 2015 09:03

HydroComp NavCad 2014

Project ID **Remolcador Rompehielos 100 TPF**
 Description
 File name **Predicción de Potencia.hcnc**

Prediction results [Propulsor]

SPEED [kt]	PROPULSOR COEFS								
	J	KT	KQ	KTJ2	KQJ3	CTH	CP	RNPROP	
0,10 !	0,0035	0,2232	0,02063	17813	465160	45361	7362400	3,00e7	
0,50 !	0,0176	0,2196	0,02037	709,55	3741,3	1806,9	59216	3,02e7	
1,00 !	0,0349	0,2151	0,02005	176,41	470,89	449,22	7453	3,04e7	
2,00 !	0,0688	0,2060	0,01940	43,535	59,628	110,86	943,77	3,09e7	
3,00	0,1015	0,1966	0,01874	19,073	17,907	48,568	283,42	3,14e7	
4,00	0,1332	0,1872	0,01808	10,558	7,6577	26,885	121,2	3,20e7	
7,00	0,2228	0,1584	0,01605	3,1892	1,4504	8,1212	22,956	3,36e7	
+ 11,00 +	0,3296	0,1203	0,01333	1,1073	0,37244	2,8198	5,8949	3,59e7	
13,00	0,3765	0,1024	0,01203	0,72195	0,22543	1,8384	3,568	3,73e7	
15,00	0,4192	0,0855	0,01080	0,48675	0,14664	1,2395	2,321	3,88e7	
SPEED [kt]	CAVITATION								
	SIGMAV	SIGMAN	SIGMA07R	TIPSPEED [m/s]	MINBAR	PRESS [kPa]	CAVAVG [%]	CAVMAX [%]	PITCHFC [mm]
0,10 !	142017,18	1,78	0,37	39,45 !!	0,727	82,30 !!	12,1	12,1	1514,8
0,50 !	5680,69	1,76	0,36	39,68 !!	0,723	81,96 !!	11,9	11,9	1531,2
1,00 !	1420,17	1,73	0,36	39,98 !!	0,719	81,51 !!	11,6	11,6	1551,7
2,00 !	355,04	1,68	0,35	40,60 !!	0,709	80,46 !!	10,9	10,9	1592,5
3,00	157,58	1,62	0,34	41,28 !!	0,698	79,42 !!	10,3	10,3	1632,8
4,00	88,48	1,57	0,32	42,01 !!	0,688	78,29 !!	9,6	9,6	1672,6
7,00	28,80	1,43	0,29	44,00 !!	0,639	72,65 !!	7,4	7,4	1791,7
+ 11,00 +	11,64	1,26	0,26	46,80 !!	0,554	62,44 !!	4,4	4,4	1947,4
13,00	8,33	1,18	0,24	48,43 !!	0,508	56,90 !!	3,2	3,2	2021,8
15,00	6,25	1,10	0,22	50,21 !!	0,462	51,11 !	2,3	2,3	2092,8

Propulsion

14 may 2015 09:03

HydroComp NavCad 2014

Project ID Remolcador Rompehielos 100 TPF

Description

File name Predicción de Potencia.hcnc

Hull data

General		Planing	
Configuration:	Monohull	Proj chine length:	0,000 m
Chine type:	Round/multiple	Proj bottom area:	0,0 m2
Length on WL:	63,961 m	LCG fwd TR:	[XCG/LP 0,000] 0,000 m
Max beam on WL:	[LWL/BWL 3,948] 16,200 m	VCG below WL:	0,000 m
Max molded draft:	[BWL/T 2,531] 6,400 m	Aft station (fwd TR):	0,000 m
Displacement:	[CB 0,661] 4495,00 t	Deadrise:	0,00 deg
Wetted surface:	[CS 2,775] 1469,2 m2	Chine beam:	0,000 m
ITTC-78 (CT)		Chine ht below WL:	0,000 m
LCB fwd TR:	[XCB/LWL 0,513] 32,825 m	Fwd station (fwd TR):	0,000 m
LCF fwd TR:	[XCF/LWL 0,465] 29,722 m	Deadrise:	0,00 deg
Max section area:	[CX 0,974] 101,0 m2	Chine beam:	0,000 m
Waterplane area:	[CWP 0,910] 942,5 m2	Chine ht below WL:	0,000 m
Bulb section area:	3,3 m2	Propulsor type:	Propeller
Bulb ctr below WL:	6,013 m	Max prop diameter:	4000,0 mm
Bulb nose fwd TR:	57,000 m	Shaft angle to WL:	0,00 deg
Imm transom area:	[ATR/AX 0,095] 9,6 m2	Position fwd TR:	0,000 m
Transom beam WL:	[BTR/BWL 0,909] 14,731 m	Position below WL:	0,000 m
Transom immersion:	[TTR/T 0,125] 0,800 m	Transom lift device:	Flap
Half entrance angle:	32,80 deg	Device count:	0
Bow shape factor:	[AVG flow] 0,0	Span:	0,000 m
Stern shape factor:	[AVG flow] 0,0	Chord length:	0,000 m
		Deflection angle:	0,00 deg
		Tow point fwd TR:	0,000 m
		Tow point below WL:	0,000 m

Propulsor data

Propulsor		Propeller options	
Count:	2	Oblique angle corr:	Off
Propulsor type:	Propeller series	Shaft angle to WL:	0,00 deg
Propeller type:	FPP	Added rise of run:	0,00 deg
Propeller series:	B Series	Propeller cup:	0,0 mm
Propeller sizing:	By power	KTKQ corrections:	Custom
Reference prop:		Scale correction:	None
Blade count:	4	KT multiplier:	1,000
Expanded area ratio:	0,5585 [Size]	KQ multiplier:	1,000
Propeller diameter:	4000,0 mm [Keep]	Blade T/C [0.7R]:	0,00
Propeller mean pitch:	[P/D 0,5500] 2200,0 mm [Keep]	Roughness:	0,00 mm
Hub immersion:	4400,0 mm	Cav breakdown:	Off
Engine/gear		Design condition	
Engine data:	AziPod CO1400	Max prop diam:	4000,0 mm
Rated RPM:	220 RPM	Design speed:	11,00 kt
Rated power:	4500,0 kW	Reference power:	4500,0 kW
Gear efficiency:	1,000	Design point:	1,000
Load correction:	Off	Reference RPM:	220,0
Gear ratio:	1,000 [Keep]	Design point:	1,000
Shaft efficiency:	1,000		

Propulsion

14 may 2015 09:03

HydroComp NavCad 2014

Project ID Remolcador Rompehielos 100 TPF

Description

File name Predicción de Potencia.hcnc

Symbols and values

SPEED = Vessel speed

PETOTAL = Total vessel effective power
WFT = Taylor wake fraction coefficient
THD = Thrust deduction coefficient
EFFR = Relative-rotative efficiency

RPMENG = Engine RPM
PBPROP = Brake power per propulsor
FUEL = Fuel rate per engine
LOADENG = Percentage of engine max available power at given RPM

RPMPROP = Propulsor RPM
QPROP = Propulsor open water torque
QENG = Engine torque
PDPROP = Delivered power per propulsor
PSPROP = Shaft power per propulsor
PSTOTAL = Total vessel shaft power
PBTOTAL = Total vessel brake power
TRANSP = Transport factor

EFFO = Propulsor open-water efficiency
EFFG = Gear efficiency (load corrected)
EFFOA = Overall propulsion efficiency [=PETOTAL/PSTOTAL]
MERIT = Propulsor merit coefficient

THRPROP = Open-water thrust per propulsor
DELTHR = Total vessel delivered thrust

J = Propulsor advance coefficient
KT = Propulsor thrust coefficient [horizontal, if in oblique flow]
KQ = Propulsor torque coefficient
KTJ2 = Propulsor thrust loading ratio
KQJ3 = Propulsor torque loading ratio
CTH = Horizontal component of bare-hull resistance coefficient
CP = Propulsor thrust loading coefficient
RNPROP = Propeller Reynolds number at 0.7R

SIGMAV = Cavitation number of propeller by vessel speed
SIGMAN = Cavitation number of propeller by RPM
SIGMA07R = Cavitation number of blade section at 0.7R
TIPSPEED = Propeller circumferential tip speed
MINBAR = Minimum expanded blade area ratio recommended by selected cavitation criteria
PRESS = Average propeller loading pressure
CAVAVG = Average predicted back cavitation percentage
CAVMAX = Peak predicted back cavitation percentage [if in oblique flow]
PITCHFC = Minimum recommended pitch to avoid face cavitation

+ = Design speed indicator
* = Exceeds recommended parameter limit
! = Exceeds recommended cavitation criteria [warning]
!! = Substantially exceeds recommended cavitation criteria [critical]
!!! = Thrust breakdown is indicated [severe]
--- = Insignificant or not applicable

Propulsion

14 may 2015 09:01

HydroComp NavCad 2014

Project ID Remolcador Rompehielos 100 TPF

Description

File name Predicción de Potencia.hcnc

Analysis parameters

Hull-propulsor interaction		System analysis	
Technique:	[Calc] Prediction	Cavitation criteria:	Keller eqn
Prediction:	Holtrop	Analysis type:	Free run
Reference ship:		CPP method:	
Max prop diam:	4000,0 mm	Engine RPM:	
Corrections		Mass multiplier:	
Viscous scale corr:	[On] Standard	RPM constraint:	
Rudder location:	Behind propeller	Limit [RPM/s]:	
Friction line:	ITTC-57	Water properties	
Hull form factor:	1,319	Water type:	Salt
Corr allowance:	ITTC-78 (v2008)	Density:	1026,00 kg/m3
Roughness [mm]:	[Off] 0,15	Viscosity:	1,18920e-6 m2/s
Ducted prop corr:	[Off]		
Tunnel stern corr:	[Off]		
Effective diam:			
Recess depth:			

Prediction method check [Holtrop]

Parameters	FN [design]	CP	LWL/BWL	BWL/T
Value	0,31	0,68	3,95	2,53
Range	0,06-0,80	0,55-0,85	3,90-14,90	2,10-4,00

Prediction results [System]

SPEED [kt]	HULL-PROPULSOR				ENGINE			
	PETOTAL [kW]	WFT	THD	EFFR	RPMENG [RPM]	PBPROP [kW]	FUEL [L/h]	LOADENG [%]
0,10 !	0,0	0,1361	0,1407	1,0109	1	0,0	---	0,0
0,50 !	0,1	0,1361	0,1407	1,0109	7	0,1	---	0,0
1,00 !	0,5	0,1361	0,1407	1,0109	13	0,5	---	0,0
2,00 !	5,0	0,1361	0,1407	1,0109	27	4,9	---	0,1
3,00	16,1	0,1355	0,1407	1,0109	40	16,0	---	0,4
4,00	36,8	0,1348	0,1407	1,0109	53	37,0	---	0,8
7,00	180,8	0,1334	0,1407	1,0109	92	185,3	---	4,1
11,00	734,5	0,1324	0,1407	1,0109	145	746,5	---	16,6
13,00	1513,9	0,1321	0,1407	1,0109	178	1479,7	---	32,9
+ 15,00 +	3602,0	0,1318	0,1407	1,0109	224	3396,0	---	75,5
POWER DELIVERY								
SPEED [kt]	RPMPROP [RPM]	QPROP [kN·m]	QENG [kN·m]	PDPROP [kW]	PSPROP [kW]	PSTOTAL [kW]	PBTOTAL [kW]	TRANSP
0,10 !	1	0,00	0,00	0,0	0,0	0,0	0,0	---
0,50 !	7	0,10	0,10	0,1	0,1	0,1	0,1	---
1,00 !	13	0,39	0,39	0,5	0,5	1,0	1,0	---
2,00 !	27	1,76	1,76	4,9	4,9	9,8	9,8	---
3,00	40	3,87	3,87	16,0	16,0	32,0	32,0	---
4,00	53	6,73	6,73	37,0	37,0	74,0	74,0	---
7,00	92	19,52	19,52	185,3	185,3	370,6	370,6	428,3
11,00	145	49,64	49,64	746,5	746,5	1493,1	1493,1	167,1
13,00	178	80,20	80,20	1479,7	1479,7	2959,4	2959,4	99,6
+ 15,00 +	224	146,08	146,08	3396,0	3396,0	6792,0	6792,0	50,1
EFFICIENCY				THRUST				
SPEED [kt]	EFFO	EFFG	EFFOA	MERIT	THRPROP [kN]	DELTHR [kN]		
0,10 !	0,4917	1,0000	0,4944	0,24282	0,01	0,01		
0,50 !	0,4872	1,0000	0,4899	0,23562	0,15	0,26		
1,00 !	0,4829	1,0000	0,4856	0,22912	0,57	0,99		
2,00 !	0,5034	1,0000	0,5062	0,26429	2,81	4,83		
3,00	0,4995	1,0000	0,5020	0,25673	6,06	10,42		
4,00	0,4961	1,0000	0,4981	0,25042	10,41	17,90		
7,00	0,4866	1,0000	0,4878	0,23471	29,21	50,20		
11,00	0,4913	1,0000	0,4919	0,24219	75,52	129,79		
13,00	0,5111	1,0000	0,5116	0,28143	131,71	226,37		
+ 15,00 +	0,5300	1,0000	0,5303	0,36311	271,60	466,79		

Propulsion

14 may 2015 09:01

HydroComp NavCad 2014

Project ID Remolcador Rompehielos 100 TPF

Description

File name Predicción de Potencia.hcnc

Prediction results [Propulsor]

PROPULSOR COEFS									
SPEED [kt]	J	KT	KQ	KTJ2	KQJ3	CTH	CP	RNPROP	
0,10 !	0,5070	0,0492	0,00808	0,19155	0,062005	0,48779	0,98139	2,14e5	
0,50 !	0,5103	0,0478	0,00797	0,18368	0,060001	0,46774	0,94967	1,06e6	
1,00 !	0,5133	0,0466	0,00788	0,17677	0,058255	0,45015	0,92204	2,12e6	
2,00 !	0,4970	0,0535	0,00840	0,2165	0,068448	0,5513	1,0834	4,37e6	
3,00	0,5005	0,0520	0,00829	0,20745	0,066095	0,52827	1,0461	6,51e6	
4,00	0,5035	0,0507	0,00819	0,20012	0,064202	0,50961	1,0162	8,64e6	
7,00	0,5107	0,0477	0,00796	0,18271	0,059755	0,46526	0,94578	1,49e7	
11,00	0,5073	0,0491	0,00807	0,19085	0,061826	0,486	0,97856	2,37e7	
13,00	0,4888	0,0569	0,00866	0,23813	0,074153	0,6064	1,1737	2,90e7	
+ 15,00 +	0,4478	0,0739	0,00994	0,36859	0,11068	0,9386	1,7517	3,64e7	
CAVITATION									
SPEED [kt]	SIGMAV	SIGMAN	SIGMA07R	TIPSPEED [m/s]	MINBAR	PRESS [kPa]	CAVAVG [%]	CAVMAX [%]	PITCHFC [mm]
0,10 !	142017,18	36507,11	7167,86	0,28	0,066	0,00	2,0	2,0	2250,9
0,50 !	5680,69	1479,41	290,28	1,37	0,066	0,02	2,0	2,0	2257,2
1,00 !	1420,17	374,17	73,37	2,72	0,066	0,08	2,0	2,0	2262,8
2,00 !	355,04	87,70	17,25	5,62	0,070	0,40	2,0	2,0	2232,0
3,00	157,58	39,48	7,76	8,37	0,073	0,86	2,0	2,0	2238,7
4,00	88,48	22,43	4,41	11,11	0,078	1,48	2,0	2,0	2244,2
7,00	28,80	7,51	1,47	19,20	0,098	4,16	2,0	2,0	2257,9
11,00	11,64	2,99	0,59	30,40	0,148	10,76	2,0	2,0	2251,4
13,00	8,33	1,99	0,39	37,30	0,210	18,77	2,0	2,0	2216,8
+ 15,00 +	6,25	1,25	0,25	47,00	0,365	38,70	2,0	2,0	2142,6

Propulsion

14 may 2015 09:01

HydroComp NavCad 2014

Project ID Remolcador Rompehielos 100 TPF

Description

File name Predicción de Potencia.hcnc

Hull data

General		Planing	
Configuration:	Monohull	Proj chine length:	0,000 m
Chine type:	Round/multiple	Proj bottom area:	0,0 m2
Length on WL:	63,961 m	LCG fwd TR:	[XCG/LP 0,000] 0,000 m
Max beam on WL:	[LWL/BWL 3,948] 16,200 m	VCG below WL:	0,000 m
Max molded draft:	[BWL/T 2,531] 6,400 m	Aft station (fwd TR):	0,000 m
Displacement:	[CB 0,661] 4495,00 t	Deadrise:	0,00 deg
Wetted surface:	[CS 2,775] 1469,2 m2	Chine beam:	0,000 m
ITTC-78 (CT)		Chine ht below WL:	0,000 m
LCB fwd TR:	[XCB/LWL 0,513] 32,825 m	Fwd station (fwd TR):	0,000 m
LCF fwd TR:	[XCF/LWL 0,465] 29,722 m	Deadrise:	0,00 deg
Max section area:	[CX 0,974] 101,0 m2	Chine beam:	0,000 m
Waterplane area:	[CWP 0,910] 942,5 m2	Chine ht below WL:	0,000 m
Bulb section area:	3,3 m2	Propulsor type:	Propeller
Bulb ctr below WL:	6,013 m	Max prop diameter:	4000,0 mm
Bulb nose fwd TR:	57,000 m	Shaft angle to WL:	0,00 deg
Imm transom area:	[ATR/AX 0,095] 9,6 m2	Position fwd TR:	0,000 m
Transom beam WL:	[BTR/BWL 0,909] 14,731 m	Position below WL:	0,000 m
Transom immersion:	[TTR/T 0,125] 0,800 m	Transom lift device:	Flap
Half entrance angle:	32,80 deg	Device count:	0
Bow shape factor:	[AVG flow] 0,0	Span:	0,000 m
Stern shape factor:	[AVG flow] 0,0	Chord length:	0,000 m
		Deflection angle:	0,00 deg
		Tow point fwd TR:	0,000 m
		Tow point below WL:	0,000 m

Propulsor data

Propulsor		Propeller options	
Count:	2	Oblique angle corr:	Off
Propulsor type:	Propeller series	Shaft angle to WL:	0,00 deg
Propeller type:	FPP	Added rise of run:	0,00 deg
Propeller series:	B Series	Propeller cup:	0,0 mm
Propeller sizing:	By thrust	KTKQ corrections:	Custom
Reference prop:		Scale correction:	None
Blade count:	4	KT multiplier:	1,000
Expanded area ratio:	0,5585 [Keep]	KQ multiplier:	1,000
Propeller diameter:	4000,0 mm [Keep]	Blade T/C [0.7R]:	0,00
Propeller mean pitch:	[P/D 0,5500] 2200,0 mm [Keep]	Roughness:	0,00 mm
Hub immersion:	4400,0 mm	Cav breakdown:	Off
Engine/gear		Design condition	
Engine data:	AziPod CO1400	Max prop diam:	4000,0 mm
Rated RPM:	220 RPM	Design speed:	15,00 kt
Rated power:	4500,0 kW	Reference power:	4500,0 kW
Gear efficiency:	1,000	Design point:	1,000
Load correction:	Off	Reference RPM:	220,0
Gear ratio:	1,000 [Keep]	Design point:	1,000
Shaft efficiency:	1,000		

Propulsion

14 may 2015 09:01

HydroComp NavCad 2014

Project ID Remolcador Rompehielos 100 TPF

Description

File name Predicción de Potencia.hcnc

Symbols and values

SPEED = Vessel speed

PETOTAL = Total vessel effective power
WFT = Taylor wake fraction coefficient
THD = Thrust deduction coefficient
EFFR = Relative-rotative efficiency

RPMENG = Engine RPM
PBPROP = Brake power per propulsor
FUEL = Fuel rate per engine
LOADENG = Percentage of engine max available power at given RPM

RPMPROP = Propulsor RPM
QPROP = Propulsor open water torque
QENG = Engine torque
PDPROP = Delivered power per propulsor
PSPROP = Shaft power per propulsor
PSTOTAL = Total vessel shaft power
PBTOTAL = Total vessel brake power
TRANSP = Transport factor

EFFO = Propulsor open-water efficiency
EFFG = Gear efficiency (load corrected)
EFFOA = Overall propulsion efficiency [=PETOTAL/PSTOTAL]
MERIT = Propulsor merit coefficient

THRPROP = Open-water thrust per propulsor
DELTHR = Total vessel delivered thrust

J = Propulsor advance coefficient
KT = Propulsor thrust coefficient [horizontal, if in oblique flow]
KQ = Propulsor torque coefficient
KTJ2 = Propulsor thrust loading ratio
KQJ3 = Propulsor torque loading ratio
CTH = Horizontal component of bare-hull resistance coefficient
CP = Propulsor thrust loading coefficient
RNPROP = Propeller Reynolds number at 0.7R

SIGMAV = Cavitation number of propeller by vessel speed
SIGMAN = Cavitation number of propeller by RPM
SIGMA07R = Cavitation number of blade section at 0.7R
TIPSPEED = Propeller circumferential tip speed
MINBAR = Minimum expanded blade area ratio recommended by selected cavitation criteria
PRESS = Average propeller loading pressure
CAVAVG = Average predicted back cavitation percentage
CAVMAX = Peak predicted back cavitation percentage [if in oblique flow]
PITCHFC = Minimum recommended pitch to avoid face cavitation

+ = Design speed indicator
* = Exceeds recommended parameter limit
! = Exceeds recommended cavitation criteria [warning]
!! = Substantially exceeds recommended cavitation criteria [critical]
!!! = Thrust breakdown is indicated [severe]
--- = Insignificant or not applicable



ANEXO VII: Report Propulsor Final

Propeller sizing analysis

14 may 2015 09:07

HydroComp NavCad 2014

Project ID Remolcador Rompehielos 100 TPF

Description

File name Predicción de Potencia.hcnc

Sizing results

To size		Design condition	
Gear ratio:	[Keep] 1	Max prop diam:	4000 mm
Expanded area ratio:	[Size] 0,5585	Design speed:	15,00 kt
Propeller diameter:	[Keep] 4000 mm	Reference thrust:	271,60 kN
Propeller mean pitch:	[Keep] 2200,0 mm	Design point:	1,000
		Reference RPM:	220,0
		Design point:	1,000



ANEXO VIII: Plano del Codaste

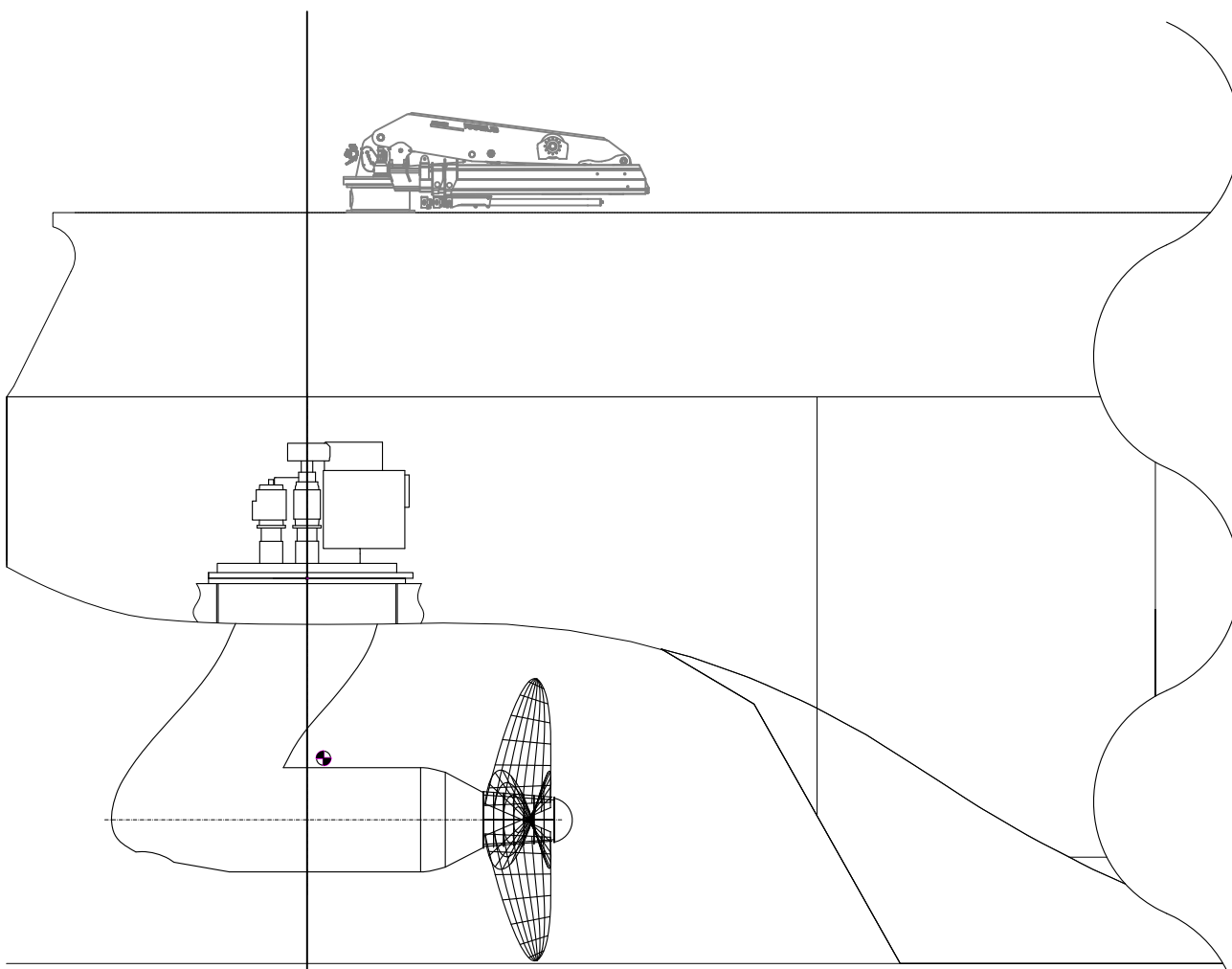

AP

0

PROYECTO
REMOLCADOR ROMPEHIELOS DE 100 TPF

CODIGO
14-04

AUTOR
 MIGUEL PÉREZ-LAFUENTE RECUNA

REFERENCIA
 CUADERNO 6 - ANEXO VIII

FECHA
 14 MAYO 2015

PLANO
 PLANO DEL CODASTE DEL BUQUE

ESCALA
1:100