

USE OF A GENETIC ALGORITHM TO OPTIMIZE WHEEL PROFILE GEOMETRY

AUTHORS

Margarita Novales. Civil Engineer, MSc, PhD. Railways Assistant Professor. University of A Coruña.

Address: ETS Ingenieros de Caminos, Canales y Puertos. Campus de Elviña, s/n. E-15071. A Coruña. Spain

Telephone: + 34 981 167000 Ext.: 1452

Fax: + 34 981 167170

E-mail: mnoval@udc.es

Alfonso Orro. Civil Engineer, MSc, PhD. Transportation Assistant Professor. University of A Coruña.

Address: ETS Ingenieros de Caminos, Canales y Puertos. Campus de Elviña, s/n. E-15071. A Coruña. Spain

Telephone: + 34 981 167000 Ext.: 1450

Fax: + 34 981 167170

E-mail: aorro@udc.es

Miguel R. Bugarín. Civil Engineer, MSc, PhD. Railways Professor. University of A Coruña

Address: ETS Ingenieros de Caminos, Canales y Puertos. Campus de Elviña, s/n. E-15071. A Coruña. Spain

Telephone: + 34 981 167000 Ext.: 1449

Fax: + 34 981 167170

E-mail: mbugarin@udc.es

KEYWORDS

- Wheel profile design
- Wheel-rail contact
- Shape optimization
- Genetic Algorithm
- Tram-train

NOTATION

E	wear energy dissipation.
F_{ξ}	longitudinal creep force.
F_{η}	transversal creep force.
M_{ζ}	spin moment.
Q	vertical force acting in wheel-rail contact point.
Y	lateral force acting in wheel-rail contact point.
y	transversal wheelset displacement.
v_{ξ}	longitudinal creepage
v_{η}	transversal creepage
σ	wheel-rail contact stress
ϕ	spin creepage

ABSTRACT

Wear is a very important subject for railway administrations. Therefore, it would be of interest to develop a methodology for designing wheel profile geometry in order to improve its behaviour in relation to this subject.

Until now, existing approach of this kind are based in statistical study of wear wheel profiles, but this do not consider characteristics of vehicles and railway tracks, and in addition, it is not an option when a vehicle is going to run, for example, over two different types of track over which mixed running never happens until now.

In this paper it is presented a new general methodology for improving wheel profiles in relation to certain physical phenomena which arise during the running of the vehicle over the tracks. This methodology is based in Genetic Algorithms technique. To show the power of this procedure, it is applied to an application case (of a tram-train in Spain), in which great improvements in the behaviour of wheel profile are achieved. In the light of this application, the importance of definition of indexes which control the evolution of the GA is shown.

USE OF A GENETIC ALGORITHM TO OPTIMIZE WHEEL PROFILE GEOMETRY

1 INTRODUCTION

Wheel profiles have a high importance in railway operation. The wheel-rail interface will be different depending on wheel and rail geometry. The interaction between the wheels and the rail has a marked influence on important factors such as safe running (derailments), dynamic behaviour of vehicle (related to vehicle stability, comfort, contact forces between wheel and rail, etc.).

In general, the standard approach of railway administrations entails establishing limitations, whether in terms of parameters related to the wheel profile (as width, height or inclination of the flange, or q_R parameter [1, 2], related to safe running over turnouts); or parameters which consider wheel and rail geometry together (as it could be equivalent conicity). When limitations are exceeded, it is necessary to reprofile wheels, or, if this operation is no longer possible, to substitute the wheelset. This reprofiling and the rejection of worn out wheels both involve significant costs for railway administrations, not only due to the reprofiling process or the necessity of using new wheels, but also due to the time during which railway vehicles are out of service when they are in the workshop for changing wheelsets or reprofiling wheels.

As it is known, wheel wear depends on the interaction between wheel and rail. In the design of a railway vehicle, the rail profile is imposed by the design of the tracks on which it is going to run; thus, it seems like a good approach to adapt the wheel profile geometry so as to obtain lower ratios of wear when running along the tracks so that there is a greater amount of time between the two subsequent reprofiles and the life of the wheel increases. This promotes savings in maintenance costs. Nevertheless, traditionally most wheel profiles currently in use have been designed with geometric criteria related to the theoretical head shape of a new rail. Furthermore, these profiles have been used on wheels mounted on very different types of vehicles with varying types of suspensions, subjected to different operating conditions and running on lines that are very diverse in terms of layout and superstructure.

It is true that in past years, some approaches were proposed which intended to develop new wheel profile geometries similar to wear profiles obtained for wheels running along the tracks,

the idea being that this equilibrium geometry will lead to lower wear ratios (this is the case of S1002 profile [3] and other applications as [4]). Nevertheless, this kind of approach is not an option when a vehicle is going to run, for example, over two different types of track over which mixed running never happens until now.

Therefore, it would be of interest to develop a methodology for designing wheel profile geometry that would account for the possibility of operation over different kind of tracks (in light of necessary interoperability in a European Railway Area without borders). Also, it would be interesting to consider design characteristics of the vehicle for this methodology.

The Genetic Algorithm (GA) technique has opened a new approach for tackling these problems.

2 GENETIC ALGORITHM TECHNIQUE APPLICATED TO WHEEL PROFILE DESIGN

Ingemar Persson and Simon Iwnicki [5] have developed a methodology which allows the improvement of wheel profiles considering the characteristics of the vehicle and its dynamic behaviour when running over the tracks. This innovative methodology is based in the use of the genetic algorithm (GA) technique.

The GA technique was first developed by John Holland at the University of Michigan in the 70's [6]. Several scientific papers have established the validity of this technique, which has been applied in business, scientific and engineering circles (for an example, see [7]).

GAs are based on Darwin's evolution theory that individuals better adapted to their environments are the ones which more effectively reproduce. This process leads to an improvement of the species in the real world, and, correspondingly, it should lead to an improvement of the wheel profile performance for this application. Using this kind of technique, populations of individuals are considered (in this case, an individual corresponds to a wheel profile geometry).

Referring to Persson and Iwnicki's methodology, the authors of this paper have developed an improved procedure which permits to analyse not only the influence of design characteristics of vehicles, but also the different kinds of tracks on which the vehicle can run. This procedure has been applied to the design of a wheel profile specifically adapted to a mixed running over railway and tramway tracks of a tram-train vehicle [8]. However, this procedure is general enough to be applied to any other case, as it could be the running of a high-speed vehicle over

railway networks that exhibit different characteristics. Figure 1 shows the flowchart of the general process for obtaining an optimized wheel profile.

The main contributions made by the authors to the previous methodology developed by Persson and Iwnicki are the following, as will be described subsequently in this paper:

- Extension of the methodology for running along two different kinds of track, obtaining independent indexes which denote the improvement of the wheel profile performance for each of them.

It is important to note that railway and light rail tracks are very different, not only in relation to their layout, but also in relation to wheel-rail contact geometry and to their mechanical behaviour (stiffness) under the loads transferred by the vehicles.

This extension implies the complete reprogramming of the genetic algorithm, changing the structure to work with the three indexes (railway index, light rail index, and a combination of both) to get the "score" of each wheel profile for each track, and for combined running (see section 3.1.4).

- The specific criteria that must be considered, in addition to wear, has been established when developing a new wheel profile adapted to combined running over railway and light rail tracks. These criteria are based on British regulations (see section 3.1).
- The main modifications and checks that have to be made for wheel profiles obtained by means of the genetic algorithm have been established so as to guarantee that the final wheel profile is suitable for operation along railway and light rail tracks (see section 3.2).

As a first phase of the process, it is necessary to develop a sufficiently complex mathematical model that simulates vehicle behaviour when running along different kind of tracks. In this case, the GENSYS program has been utilised [9].

In this first phase, the vehicle is provided with two different wheel profiles, contrasted by the practice. Once the results have been obtained from the GENSYS simulation of the vehicle running on the two different kinds of tracks with these two wheel profiles, the appropriateness of these two wheel profiles in terms of the criteria under consideration is determined, and the GA automatically develops new wheel profiles as a combination of previous ones (see [10]).

The wheel profile geometry is defined in a discrete form, by means of points along x and y

coordinates, where x is the horizontal distance to the rolling radius of the wheel and y is the vertical distance to that point. These points are defined every 0.5 mm along the horizontal axis. The GA obtains the geometry of every new wheel profile through semi-random combination of the fourth derivative (obtained in an incremental manner) of two wheel profiles of last generation (see [10]).

This process is repeated until the improvement obtained for considered criteria is slight; this is the moment at which the GA process ends.

3 APPLICATION TO A TRAM-TRAIN CASE IN SPAIN

This epigraph will present the application of this methodology to the case of a Spanish tram-train running on tramway tracks and the conventional railway tracks of Spanish Metric Gauge Railway Administration (FEVE), see [10].

3.1 Criteria considered

In general, in order to obtain a new wheel profile improved in terms of wear, it is necessary to consider other criteria - not only wear - because in other cases there will exist the risk that improvements in wear are achieved at the expense of other critical phenomena, such as risk of derailment. So, the generation of wheel profiles in the GA is based, in this application case, on the following criteria:

- Derailment criterion
- Wear criterion
- Wheel-rail contact stresses criterion.

These are the potential risks that the British Railway Group Guidance Note Standard GE/GN-8502 [11] specifies when developing new wheel profile geometries to be used in tram-train vehicles. There are no other requirements for any other standard related to tram-train, and this is why these risks are considered in this Spanish application.

Nevertheless, the methodology should account for other criteria related to other physical phenomena that are of importance in any other case study (such as lateral forces on the track, comfort, etc.).

These criteria must be expressed in the form of indexes so that they can be introduced into the GA process. The way in which these indexes are defined is explained in the following sections.

The specific procedure for intruding these indexes in the GA to control the process can be referred to in [10].

3.1.1 Risk of derailment (I_{YQ} Index)

Risk of derailment is related to the Y/Q relation (between vertical and transversal forces acting on the wheel-rail contact).

According to the CEN PNE-prEN 14363 [12] and the UIC 518 [13], the Y/Q limit for derailment risk occurrence is 0.80. Furthermore, this value must be maintained at a distance of around 2 m for derailment to occur. So, a filter of Y/Q values in sections of this length is made throughout the layouts considered.

To obtain I_{YQ} , the maximum values of the filtered Y/Q quotients are studied for all the vehicle's wheels, and the YQ_{Factor} variable is then achieved by dividing the maximum filtered Y/Q value by 0.8. Then, the interpolation curve shown in Figure 2 is used to obtain the I_{YQ} value. As can be seen, when a wheel profile gives values close to derailment risk limit ($YQ_{Factor} = 1$), the I_{YQ} value increases significantly, giving a very poor result for the wheel profile in relation to this phenomenon.

3.1.2 Wear (I_{Wear} Index)

The wear energy dissipation (i.e., the energy lost per meter travelled due to wear) is considered in order to study the wear, assuming that wheel wear is almost directly proportional to this dissipation [14].

In order to determine the wear energy dissipation, the products of the transversal (F_{η}) and longitudinal (F_{ξ}) creep forces by the respective creepages (v_{η} and v_{ξ}) are calculated both on the wheel tread and the flange (should contact on the flange exist). The products of the spin moments (M_{ζ}) and the corresponding spin creepage (ϕ), on the wheel tread and flange are likewise calculated. Finally, the results are added together. Thus, the energy dissipation may be expressed as shown below:

$$E_{ij}(x) = (F_{\xi} \times v_{\xi})_{tread,ij} + (F_{\xi} \times v_{\xi})_{flange,ij} + (F_{\eta} \times v_{\eta})_{tread,ij} + (F_{\eta} \times v_{\eta})_{flange,ij} + (M_{\zeta} \times \phi)_{tread,ij} + (M_{\zeta} \times \phi)_{flange,ij}$$

Where x refers to the position of the vehicle on the track layouts; sub-index i refers to the wheelset in which the wheel is located; and sub-index j indicates whether it is the right or the left

wheel. If there is no contact on the flange, corresponding values are 0.

Once the $E_{ij}(x)$ distributions over track layouts have been obtained for all the vehicle wheels, they are statistically processed in order to get the average value for each of them. This average value is saved as variables \bar{E}_{ij} . The average values of the eight wheels are then added together to obtain the total wear energy dissipation for the vehicle, which is kept as variable E_{Total} . The I_{Wear} value is obtained from E_{Total} , by means of the interpolation curve shown in Figure 2.

The interpolation curve has been determined by assuming that 8 to 12 Nm/m is a good wheel wear energy dissipation average value (these values are determined by experience). Consequently, taking into account that the vehicle under consideration has eight wheels, a total wear energy dissipation value of 96 Nm/m is established as a good value. So, a value of I_{Wear} zero is established until E_{Total} reaches 100 Nm/m, given that the wheel profile is performing correctly with regard to this criterion. When a value of 100 is exceeded, a lineal variation of the index from 0 to 1 is established for values of E_{Total} from 100 to 250. This is due to the fact that 30 Nm/m is considered as the standard upper limit for the average wheel wear energy dissipation. For values higher of E_{Total} , the I_{Wear} is increased in the same proportion, and will therefore rise with any increases in the E_{Total} value (an increasingly poor profile in terms of this criterion).

3.1.3 Wheel-rail contact stresses (I_{Stress} Index)

In the first approach, wheel-rail contact stresses were considered as a safety measure in order to avoid the evolution towards profiles with sharp edges, which are unsuitable for the desired objective and could give rise to stress build-ups. Nevertheless, in light of initial results obtained, it is evident that the controlling influence of this criterion on the development of new geometries is greater than was believed in the first phase. This will be shown in the subsequent epigraphs to this paper.

In order to achieve this index, it is necessary to determine the value of the wheel-rail contact stresses throughout the track layouts. These values are contained in the variables $\sigma_{ij}(x)$, where sub-indexes i and j are the same as for the wear. In the event of double contact (on the flange and tread) the maximum stress value produced in each contact zone will be kept.

Once the variables $\sigma_{ij}(x)$ have been obtained, a statistical processing is then performed in order

to get the average values ($\bar{\sigma}_{ij}$) and standard deviation (s) for each of them. The maximum characteristic value for each is obtained through the following formula:

$$\sigma_{ij_{\max}} = \bar{\sigma}_{ij} + 3 \times s(\sigma_{ij}(x))$$

in accordance with the instructions included in appendix H of leaflet UIC-518 [13] for variables related to running safety.

Once the $\sigma_{ij_{\max}}$ values have been determined, the highest value of these is divided by 10^9 N/m^2 to obtain I_{Stress} . Thus, an index equal to 1 is obtained when the maximum stress is 1000 MPa (considered to be a reasonable value). The index value is directly proportional to maximum stress, worsening the fitness of the wheel profile in accordance with the increase of this parameter.

3.1.4 Combination of partial indexes

Once the partial indexes have been obtained, they must be combined to get a total index which denotes the suitability of the wheel profile in relation to considered criteria. In this application case, the combination is made by means of the following formula:

$$I_T = I_{YQ} + 4 \lambda_{\text{Wear}} + I_{\text{Stress}}$$

In this way, the wear index is of greater importance when the evolution is implemented, as it was desirable due to implications which wear has for maintenance costs.

In addition, in this application case, running on the two kinds of track (light rail and railway) must be considered. To this end, the total index is calculated with the results of partial indexes obtained with simulations over the layouts of these two types of track. So, two total indexes result: the total railway index (I_{TF}) and the total light rail index (I_{TT}). Lastly, to obtain the final index to consider, which controls the evolution of the GA, the following formula is used:

$$I_{TP} = \rho_1 \lambda_{TF} + \rho_2 \lambda_{TT}$$

where ρ_1 and ρ_2 are the weighting quotients for each type of network. These weighting quotients will depend on the actual lengths of the different kinds of tracks that the vehicle will run on; and on the other hand, on the average frequencies along those lines.

For the purposes of the application case being presented, the actual railway track has been

taken to be approximately 20 km, whilst the light rail track is merely 4 km in length. Likewise, the average frequency in the city centre area is considered to be twice that of the regional area. These data indicate that the actual route will consist of 20 km of railway track per 8 km of light rail track, and therefore the weighting quotients for each index will be $\rho_1 = 20/28 = 5/7$ for the I_{TF} , and $\rho_2 = 8/28 = 2/7$ for the I_{TT} .

3.2 Final checks and adjustments

Once the convergence criterion has been met, the best wheel profiles obtained must be selected, and the corresponding checks and adjustments made, to determine the suitability of the new wheel profiles. This procedure is shown in Figure 3 and consists of the following stages:

- The best wheel profiles obtained are selected and modified in order to obtain two objectives:
 - A flange height adapted to that used in the railway administration for which the study is being carried out (28 mm in this application case). This change is made while maintaining the geometry of the active side of the wheel profile generated by the GA.
 - Adaptation of the geometry obtained in the GA to a new simplified geometry made up of straight lines and circular curves.
- The simulations are repeated using the best modified wheel profiles in order to obtain the variation of the indexes resulting from geometrical modifications. This variation should not be significantly high, since the geometrical modifications are only slight.
- To guarantee safety when running over points [15], the value of q_R (see [1, 2]) on the modified wheel profiles must be checked, and one of the best profiles in terms of this parameter is selected.
- Once the profile has been selected, a study is made to ensure that it meets the limits established in relation to the equivalent conicity.
- If the profile is valid, then the process is considered to be completed, and the adapted wheel profile has been obtained. If this is not the case, then it is necessary to go back two steps and select the next profile that best fits the q_R limit.

3.3 Initial results

The improved wheel profile, obtained by means of this methodology, is shown in Figure 4. This wheel profile has been obtained with the following data:

- ❑ Initial wheel profiles shown in Figure 5, the first one corresponding to a standard Spanish light rail type and the second one to a standard Spanish railway type for metric-gauge lines.
- ❑ Mechanical and geometric characteristics of a general tram-train vehicle.
- ❑ Definition of indexes shown previously.

In this case, the I_{TP} index is improved by 36% in comparison with the best initial profile. The partial indexes improve by 52% and 15% for I_{TF} and I_{TT} , respectively. Greater improvements in the I_{TF} index are due, on the one hand, to the greater weighting that has been given to this index within the I_{TP} index, and, on the other hand, to the fact that the layout for light rail tracks is more stringent, and thus the possibility of improving the behaviour by means of the wheel profile is smaller.

In terms of partial indexes, the greatest improvement is observed in relation to I_{Wear} (67% for running on railway track and 20% for light rail track). This denotes very good performance of the methodology. The other two partial indexes improve to a lesser degree in the case of railway track (4.77% for I_{YQ} and 25.51% for I_{Stress}), and are slightly worse in the case of light rail track (worsening by 2.24% for I_{YQ} and 2.24% for I_{Stress}).

In Figure 6, the variation of the main parameters (Y/Q value, wear energy dissipation and wheel-rail contact stresses) can be seen for the critical wheel (exterior wheel of first wheelset of the first bogie) when the vehicle is running on the modelled railway track. R represents the curve radius over each section of the track. When there is no R specification, it represents a straight zone. As can be seen, there is a significant improvement (decrease) of wear energy dissipation values, which corresponds to improvement of wear index on railway track (67%), while the other parameters improve in a lesser degree (corresponding to the lower improvement of the other partial indexes).

In light of q_R results, the selected profile is not the best wheel profile obtained by the GA, but the best one with good results for q_R (q_R value of 9.05 mm is considered sufficient; the new FEVE wheel profile has a q_R of 9.33, and the minimum value allowed is 6.50 mm). This wheel profile produces considerably improved indexes in comparison with the initial wheel profiles used in the

GA.

The equivalent conicity check for a transversal wheelset displacement of $y = \pm 3$ mm is carried out on this profile. In the case of railway track, a value of 0.163 is obtained, which is below the limits established by the UIC-518 leaflet [13] and the UNE-ENV 12299 standard [16] of 0.50 and 0.40, respectively, for speeds below 140 km/h. In terms of equivalent conicity over light rail track zones, a value of 0.454 is obtained for that value of y ; this does not meet the UNE standard limits, although it does comply with the UIC standard. However, it is not necessary to comply with this limit in light rail track zones, as it is established for far higher speeds than those used in urban areas. In any case, the subject of conicity will be reintroduced below because it has additional consequences.

So, after making the corresponding checks, the chosen wheel profile adapted for mixed running in this first stage has the geometry shown in Figure 7. Once this geometry of the active side of the wheel profile has been obtained, further checks must be made that aim to guarantee the guiding over track equipment on FEVE lines (see [10]).

From Figure 4, it can be observed that wheel conicity increases significantly in contrast to original wheel profiles. This effect is due to the fact that the yaw stiffness is low to favour running over urban tracks which follow street layouts and which therefore have very tight curve radii. Nevertheless, this vehicle itself has to operate over conventional railway tracks, and the running stability of bogies must be maintained despite this conicity increase. This is not a problem because the wheel profile passes the equivalent conicity check when running on railway tracks, as has been demonstrated previously.

This conicity leads to an increase of contact stresses between wheel and rail, because these contacts are concentrated in the zones of rail profile with lower radii (which leads to small contact ellipse dimensions), especially when running on tramway tracks, as can be seen in Figure 8. This increase in contact stresses does not lead to a greater worsening of the I_{Stress} index, for the higher maximum values are counteracted by lower standard deviations from the mean value of these stresses.

In any case, these results confirmed the importance of sufficiently considering the indexes involved in the process of generating new wheel profiles with the GA. Indeed, in this first approach, the definition of the I_{Stress} had an excessively simple definition, because it was

considered only as a check criterion.

3.4 Corrected results

Considering the facts detailed in the previous section, the I_{Stress} criterion was modified, obtaining I_{Stress} from the highest value of $\sigma_{ij\text{max}}$ by means of the interpolation curve shown in Figure 9.

This modification of the I_{Stress} leads to a new wheel profile geometry obtained by means of the GA. The new geometry and new contact points between wheel and rail for the two kinds of tracks are shown in Figure 10.

The new definition of I_{Stress} leads to greater contact stresses, and thus the GA evolves towards profiles with lower conicity (as can be seen in Figure 10), which give lower values for this parameter due to lower concentration of contacts in the zones of rail profile with lower radii.

In this case, the I_{TF} improves by 30.93% (due to improvement by 24.52% of the I_{Wear} and 61.25% of I_{Stress} , and a slight worsening in I_{YQ} by 6.76%). On the other hand, the I_{TT} worsens by 1.25% (due to improvement by 1.93% of the I_{Wear} and the slight worsening of the I_{Stress} by 6.38% and I_{YQ} by 4.72%). These worse I_{Stress} values for light rail tracks are not due to increases in stress values, but to worse valuation of better values due to a more severe definition of the index.

4 CONCLUSIONS

This paper has presented a new methodology which makes it possible to obtain the wheel profile geometry of a railway vehicle in relation to its dynamical characteristics, and to characteristics of the railway tracks on which the vehicle is going to run. This methodology is able to get an improvement of the dynamic behaviour of the vehicles on these tracks, which leads to better performances in such important subjects as wear.

The proposed methodology is based on the GA technique. The fitness of the solution is established by means of indexes which numerically consider the most important phenomena in the problem at hand. Obviously, these phenomena may vary depending on the case to be solved.

The results obtained have verified the importance of correct definition and choice of indexes. For a correct application of this methodology, it is necessary to have a deep and rigorous knowledge of running conditions, the criteria considered in order to improve the wheel profile,

the mathematical translation of the criteria in the form of indexes and the limit value of the physical parameters, different for each railway administration and case to analyze.

ACKNOWLEDGEMENTS

The authors thank Ingemar Persson for assisting with the development phase of the dynamic model on the GENSYSS program, as well as for providing the initial GA, which has been modified for developing the application presented in this paper.

They also thank the Spanish Ministerio de Fomento for its financial contribution to the project entitled "Study about necessary modifications in infrastructure and rolling stock for the interoperability between conventional and urban rail networks. Guidelines for the future standardization of networks and rolling stock for the achievement of said interoperability" (in Spanish).

REFERENCES

- 1 **García Díaz-de-Villegas, J.M., Rodríguez Bugarín, M.** *Railway Turnouts*, Santander, 1995, Ingeniería Cántabra, S.A. ISBN: 84-605-4337-4. (In Spanish).
- 2 **U.A.** *Question C 70: Profils d'usure mutuellement admissibles pour les bandages et les appareils de voie*, Utrecht, 1970, Office de Recherches et d'Essais de l'Union Internationales des Chemins de Fer.
- 3 **U.A.** *Question S 1002: Unification des profils de roues, RP-2: Recommandations concernant un profil de roue unique adapté à l'usure (profil UIC-ORE), valable quels que soient le diamètre des roues et le type de véhicule*, Utrecht, 1973, Office de Recherches et d'Essais de l'Union Internationales des Chemins de Fer.
- 4 **Gallego, G., Antolín, A.** Reduction of maintenance costs through an optimum wheel profile. *World Congress on Railway Research 1997*, Firenze, Italy, 1997.
- 5 **Persson, I., Iwnicki, S.D.** Optimization of railway wheel profiles using a Genetic Algorithm, *18 th IAVSD Symposium*, Kanagawa Institute of Technology, Kanagawa-ken, Japan, August 25th – 29th 2003.
- 6 **Goldberg, D.E.** *The design of Innovation: Lessons from and for competent Genetic Algorithms*, Kluwer Academic Pub, Norwell, 2002. ISBN: 1-402-07098-5.
- 7 **Mei, T.X., Goodall, R.** Use of multiobjective genetic algorithms to optimize inter-vehicle

- active suspensions. *Proceedings of the Institution of Mechanical Engineers, Part F, Journal of Rail and Rapid Transit*, 2002, 216 (1), 53-63.
- 8 **Novales, M., Orro, A., Bugarín, M.R.** Tram-train. New public transport system, *Transportation Research Record 1793*, TRB, National Research Council, Washington, D.C., 2002, pp. 80-90.
 - 9 **DEsolver.** *GENSYS.0303 Reference Manuals*, Östersund, 2003.
 - 10 **Novales, M.** Analysis and development of technological adaptations in infrastructure and vehicles for implantation of tram-train systems over tracks of Spanish Metric Gauge Railway Administration (FEVE), Ph.D. Dissertation (in Spanish), University of La Coruña, 2004.
 - 11 **Safety and Standards Directorate.** *Guidance Note GE/GN-8502, Operation of trams and light rail or metro vehicles over Railtrack controlled infrastructure*. London, 1999, Railtrack.
 - 12 **CEN (European Committee for Standardization).** *Draft PNE-prEN 14363, Railway applications – Testing for the acceptance of running characteristics of railway vehicles – Testing of running behaviour and stationary tests*. Brussels, 2002.
 - 13 **UIC (Union Internationale des Chemins de fer).** *Code UIC 518 OR: Essais et homologation de véhicules ferroviaires du point de vue du comportement dynamique - Sécurité - Fatigue de la voie - Qualité de marche*, 2^a Ed., Paris, 2001, UIC. ISBN: 2-7461-0351-6.
 - 14 **Andersson, E., Berg, M., Stichel, S.** *Rail vehicle dynamics*, Railway Group KTH, Centre for Research and Education in Railway Engineering, Stockholm, 2005.
 - 15 **Novales, M., Orro, A., Bugarín, M.R.** Madrid tram-train feasibility study conclusions. *Proceedings of the Institution of Mechanical Engineers, Part F, Journal of Rail and Rapid Transit*, 2003, 217 (1), 1-10.
 - 16 **CEN (European Committee for Standardization).** *UNE-EN 12299, Railway applications. Ride comfort for passengers. Measurement and evaluation*, Brussels, 2000.

FIGURES INDEX

Figure 1: "General process for obtaining wheel profiles adapted to running conditions".

Figure 2: "Interpolation of I_{YQ} and I_{Wear} indexes".

Figure 3: "Final operations to be carried out on the wheel profiles obtained by means of the GA"

Figure 4: "Improved wheel profile obtained by means of the GA".

Figure 5: "Initial wheel profile geometries used to start the evolution of the GA"

Figure 6: "Variation of main parameters for the critical wheel when the vehicle is running over the modelled railway track. a) Y/Q value. b) Wear energy dissipation. c) Wheel-rail contact stress".

Figure 7: "Chosen wheel profile for application case presented".

Figure 8: "Wheel-rail contacts for selected wheel profile in railway (UIC-54 rail inclined 1:20) and tramway (vertical Ri-60 rail) tracks".

Figure 9: "Interpolation for new I_{Stress} index".

Figure 10: "a) Comparison of improved wheel profiles obtained with first and new definition of I_{Stress} index. b) Wheel-rail contacts for improved wheel profile (obtained with new definition of I_{Stress}) in railway tracks (UIC-54 rail inclined 1:20). c) Ídem in tramway tracks (vertical Ri-60 rail)".

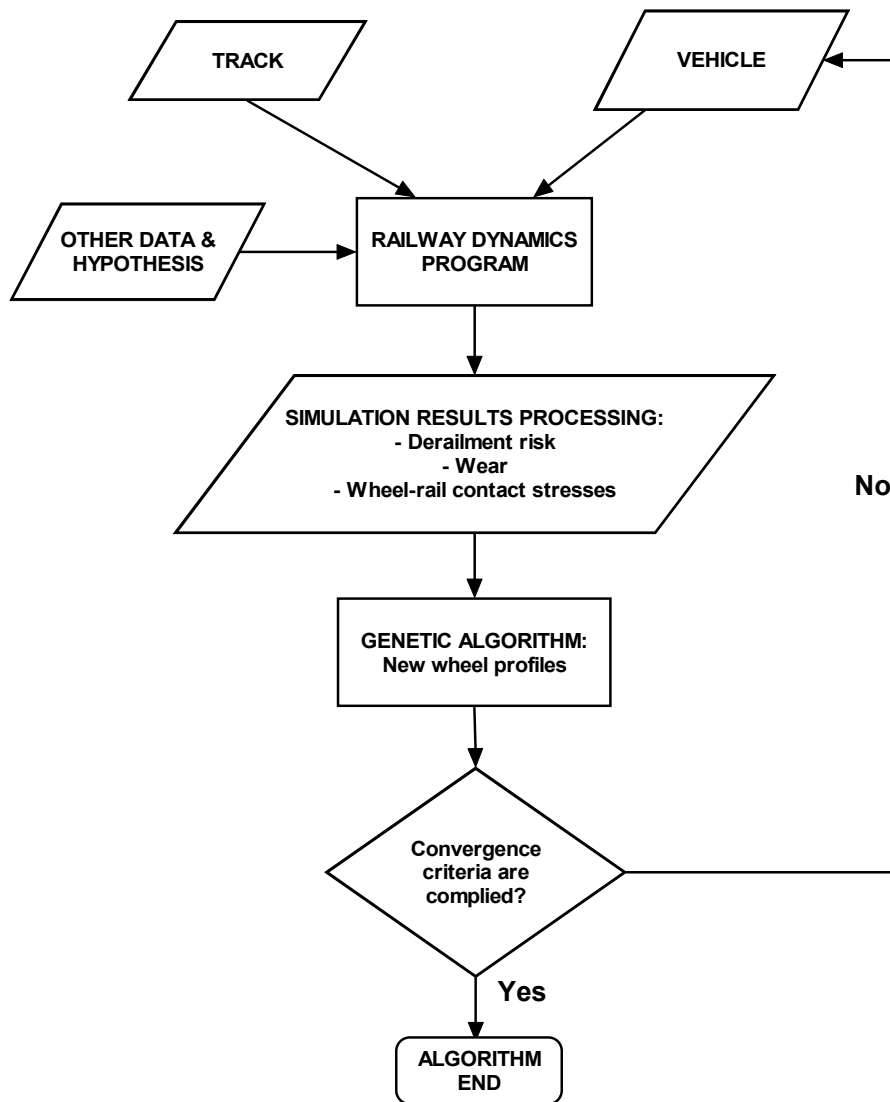

Figure 1: General process for obtaining wheel profiles adapted to running conditions.

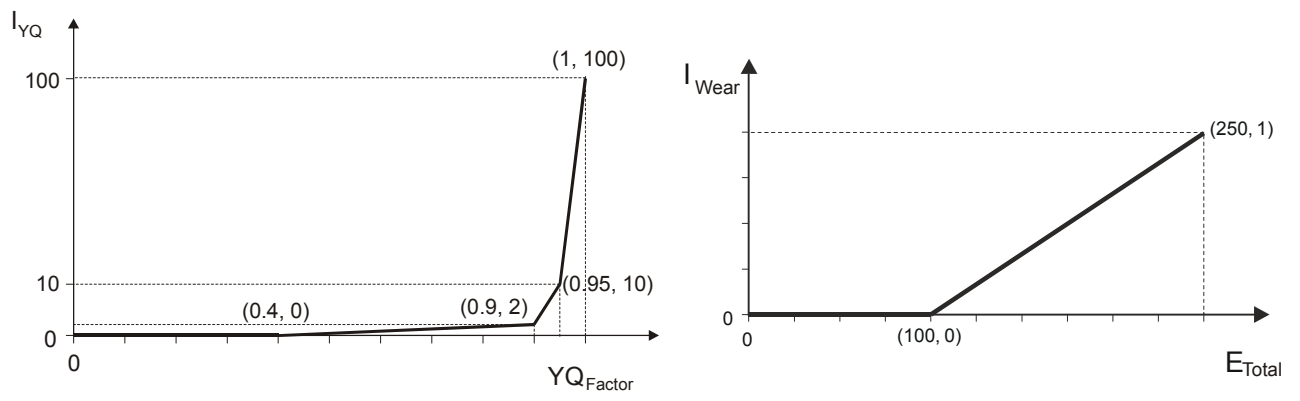

Figure 2: Interpolation of I_{VQ} and I_{Wear} indexes.

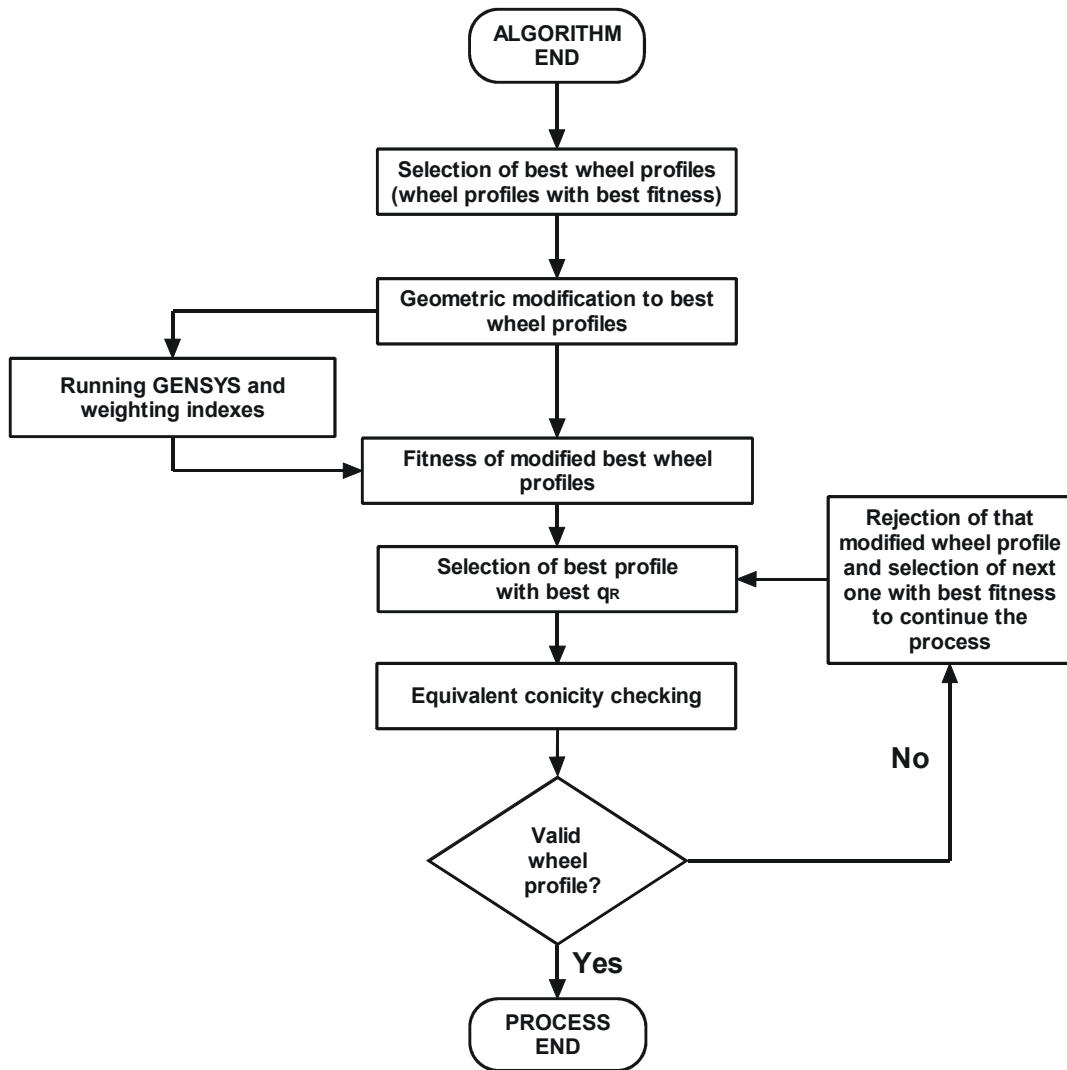

Figure 3: Final operations to be carried out on the wheel profiles obtained by means of the GA.

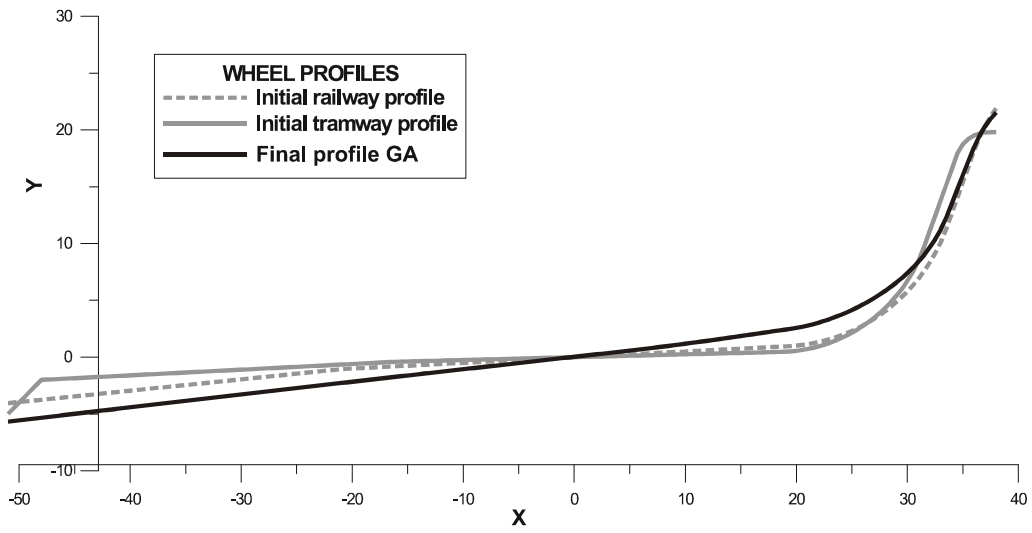

Figure 4: Improved wheel profile obtained by means of the GA.

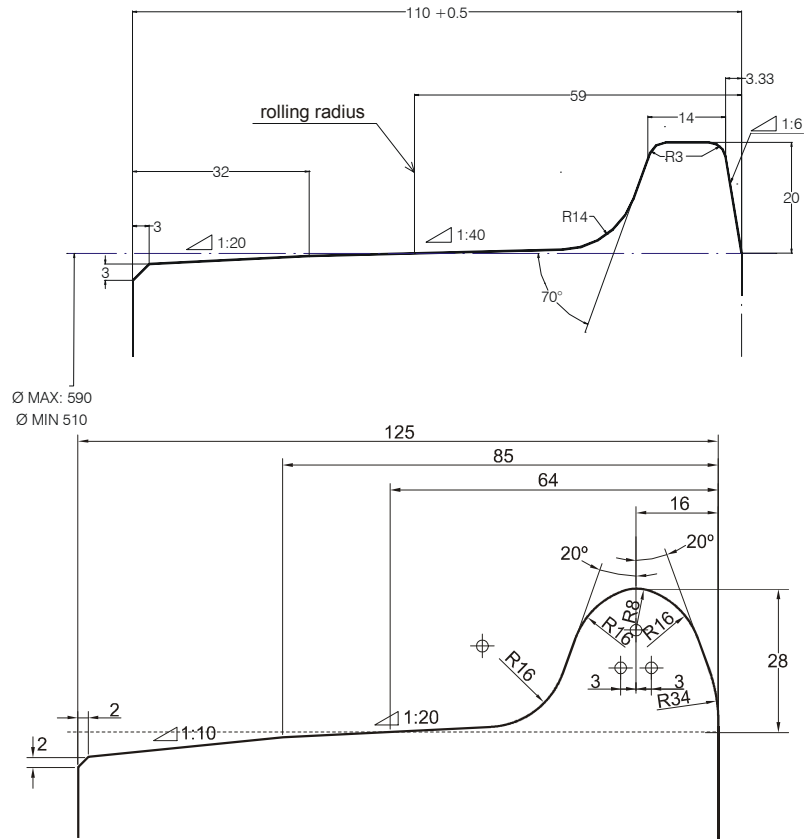
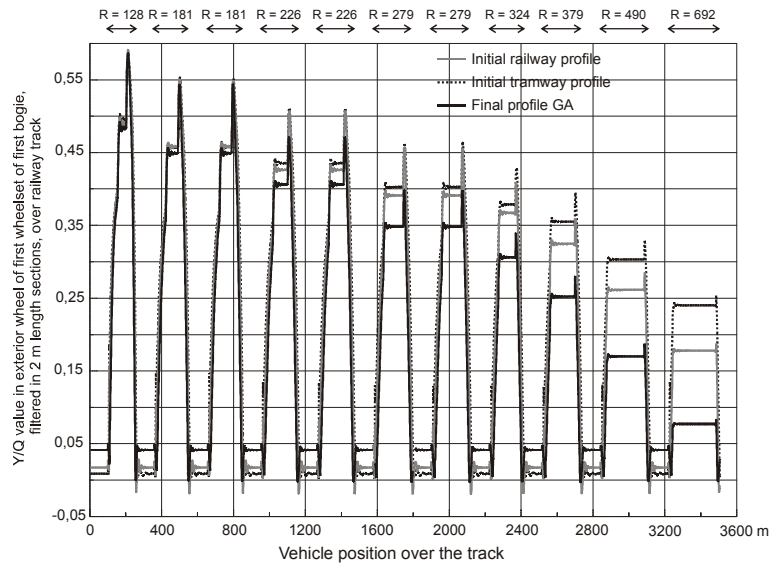
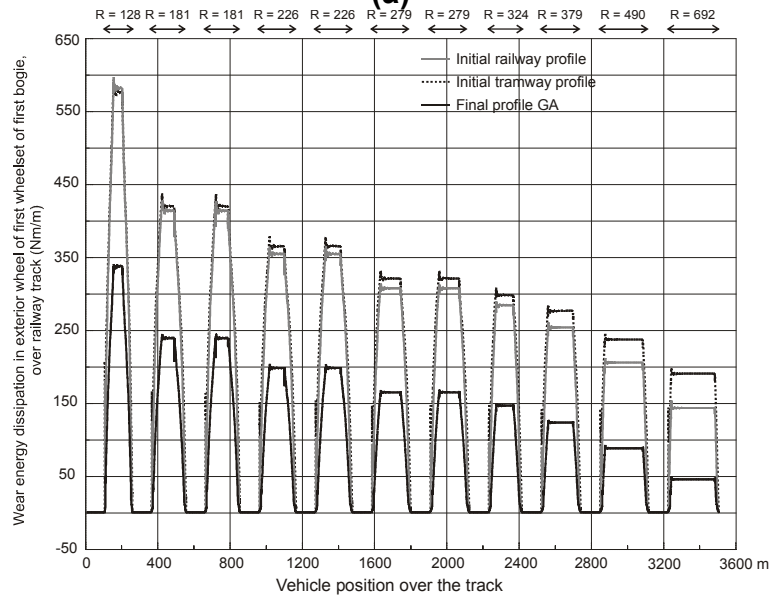

Figure 5: Initial wheel profile geometries used to start the evolution of the GA.



(a)



(b)

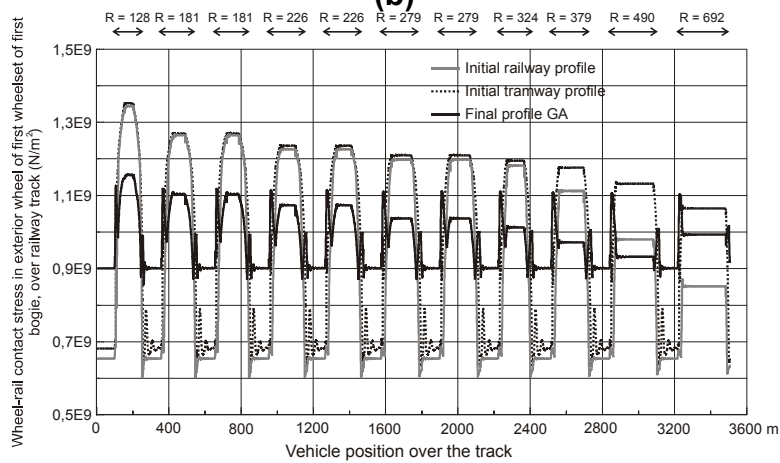

(c)

Figure 6: Variation of main parameters for the critical wheel when the vehicle is running over the modelled railway track. a) Y/Q value. b) Wear energy dissipation. c) Wheel-rail contact stress.

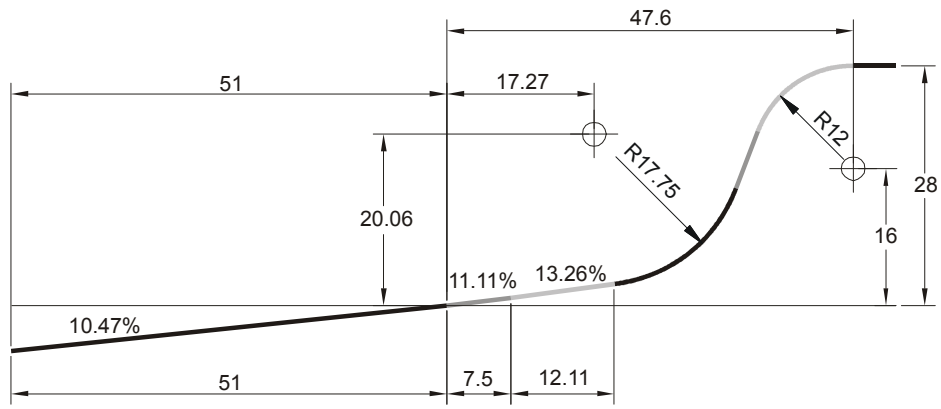

Figure 7: Chosen wheel profile for application case presented.

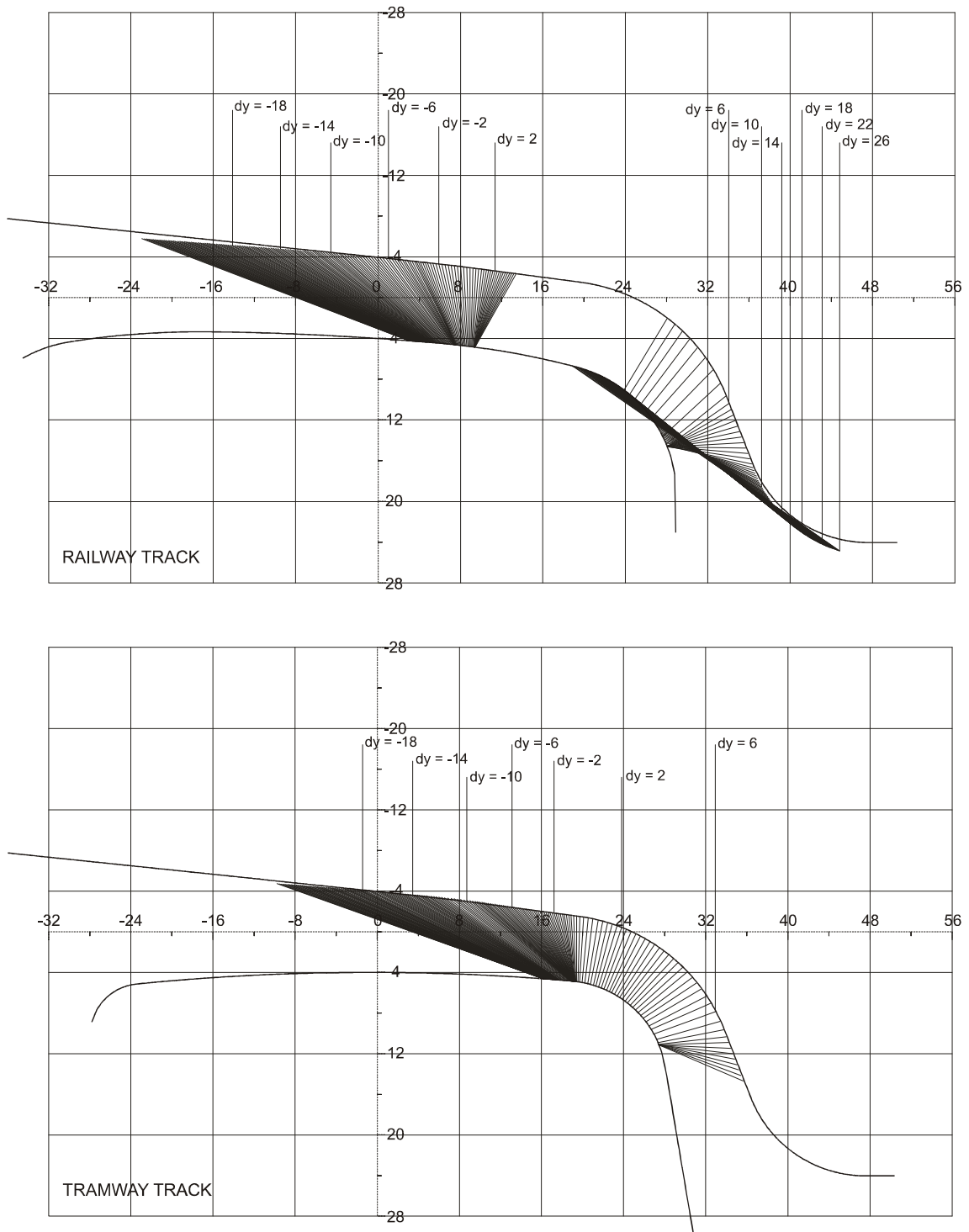

Figure 8: Wheel-rail contacts for selected wheel profile in railway (UIC-54 rail inclined 1:20) and tramway (vertical Ri-60 rail) tracks.

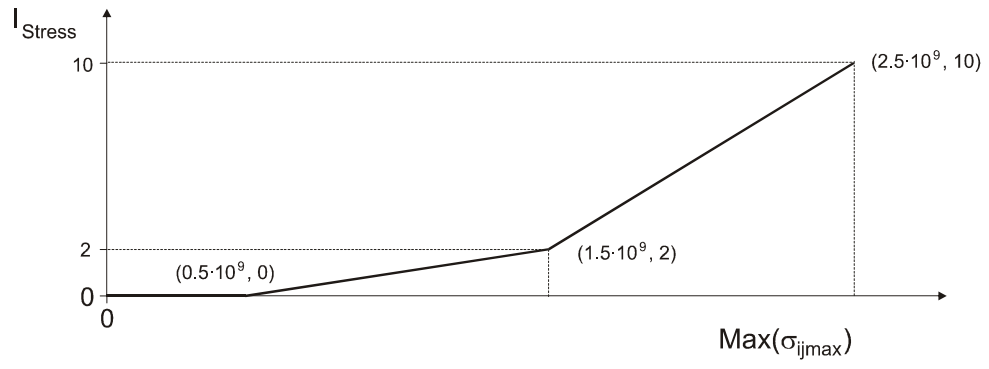

Figure 9: Interpolation for new I_{Stress} index.

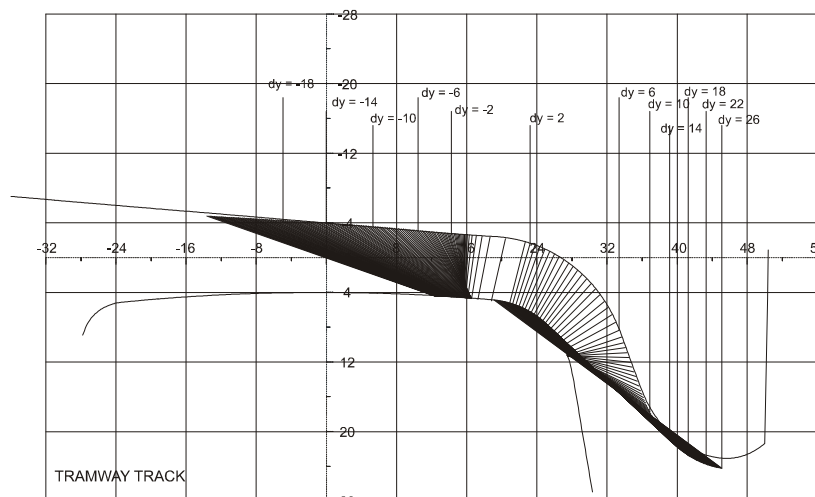
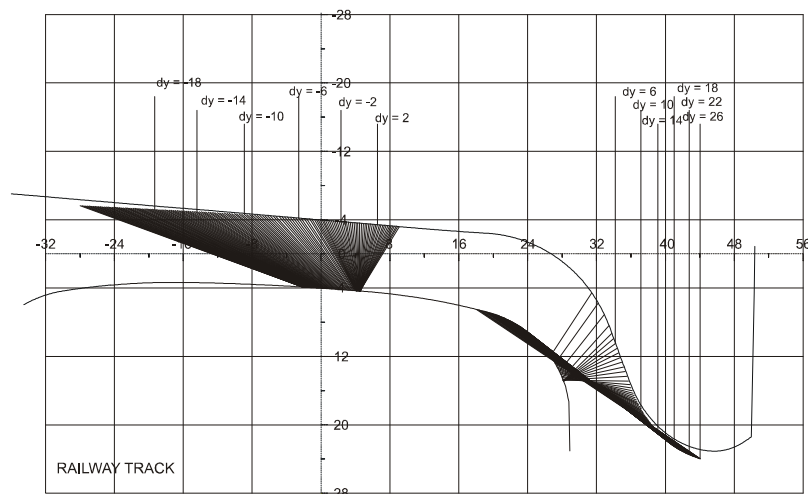
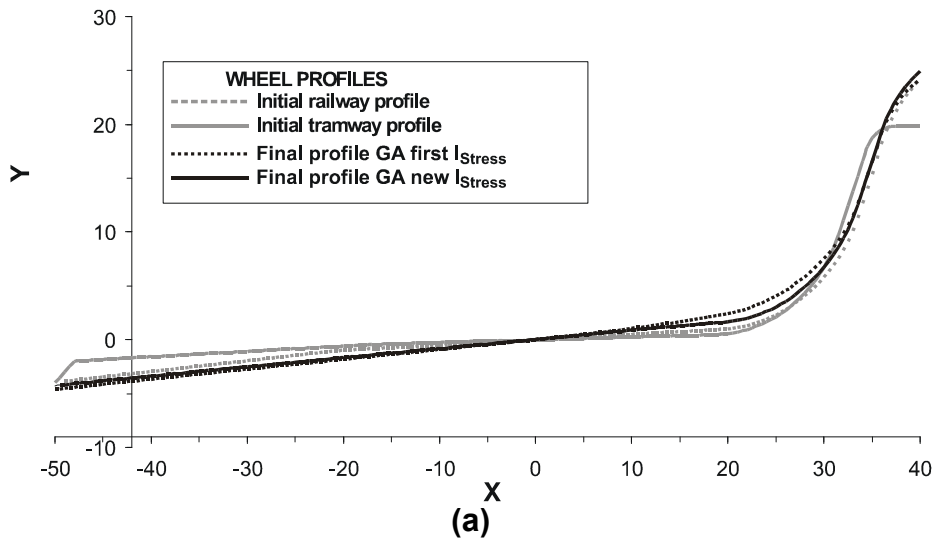

Figure 10: a) Comparison of improved wheel profiles obtained with first and new definition of I_{Stress} index. b) Wheel-rail contacts for improved wheel profile (obtained with new definition of I_{Stress}) in railway (UIC-54 rail inclined 1:20) tracks. c) Ídem in tramway (vertical Ri-60 rail) tracks.