

- | | | | | | |
|----|------------------------------------|----|----------------------|----|--------------|
| 1 | ALMAS BEBIENDO EN UNA FONTS VITAE | 11 | LA MAGDALENA | 21 | LA TEMPLANZA |
| 2 | ÁNGELES CON INSTRUMENTOS MUSICALES | 12 | FERNÁNDO EL CATÓLICO | 22 | LA JUSTICIA |
| 3 | SAN PEDRO | 13 | ISABEL LA CATÓLICA | 23 | LA FORTALEZA |
| 4 | SANTIAGO EL MAYOR | 14 | SANTA CATALINA | 24 | LA PRUDENCIA |
| 5 | EL SALVADOR | 15 | SANTA LUCÍA | 25 | EL ASTRÓLOGO |
| 6 | VIRGEN | 16 | FERNÁNDO EL CATÓLICO | 26 | EL PEREGRINO |
| 7 | SAN JUAN EVANGELISTA | 17 | ISABEL LA CATÓLICA | 27 | EL MEDICO |
| 8 | SAN PABLO | 18 | ADÁN | 28 | EL ASTRÓLOGO |
| 9 | SAN JUAN BAUTISTA | 19 | EVA | | |
| 10 | LOS APÓSTOLES | 20 | CRUZ DE JERUSALÉN | | |

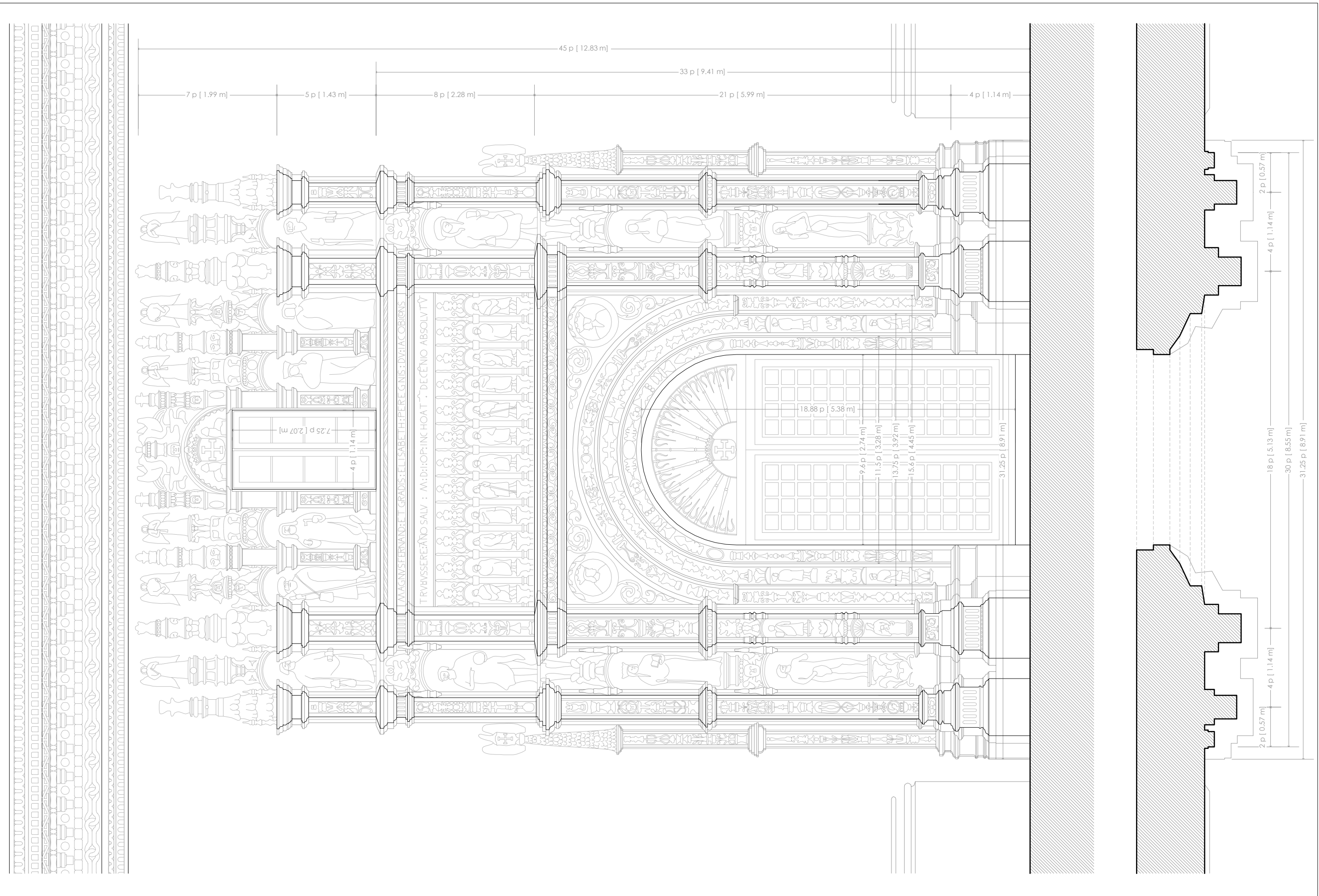

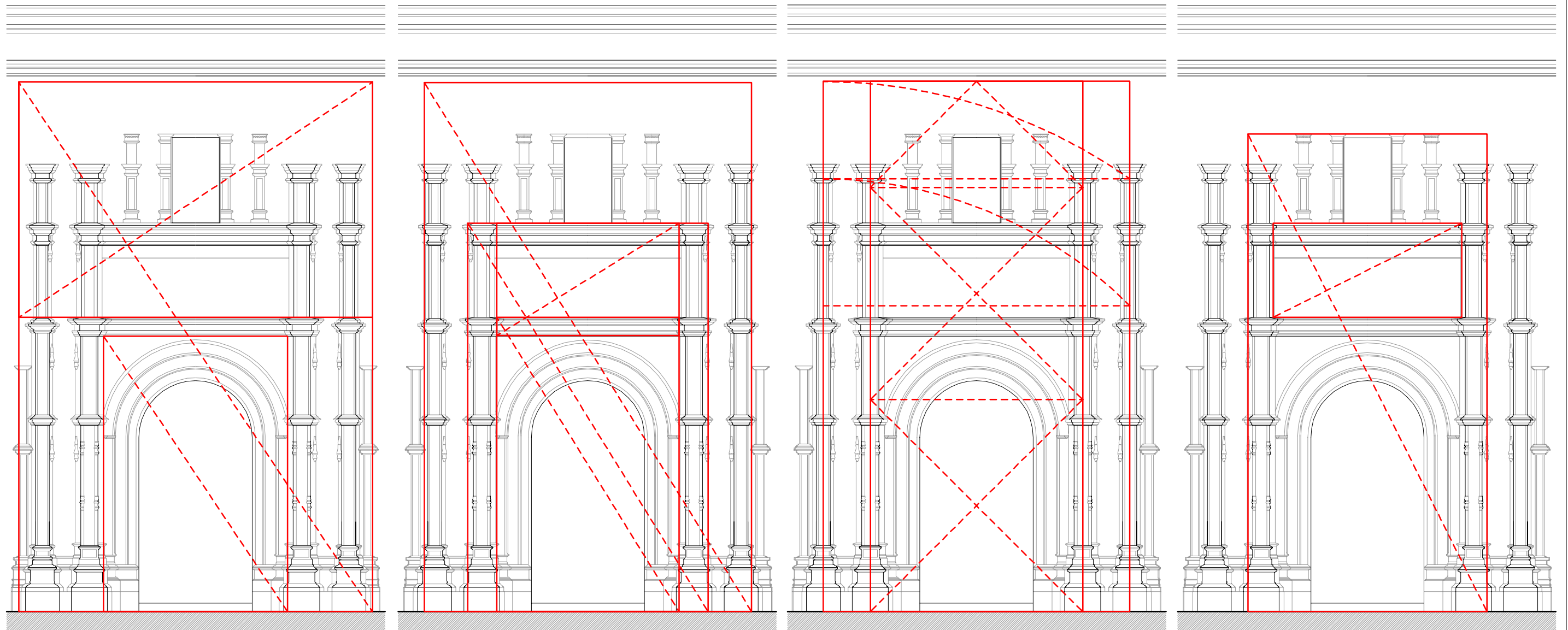

PROPORCIÓN 3:2

PROPORCIÓN ÁUREA

PROPORCIÓN $\sqrt{3}$ 5:2

PROPORCIÓN 2:1

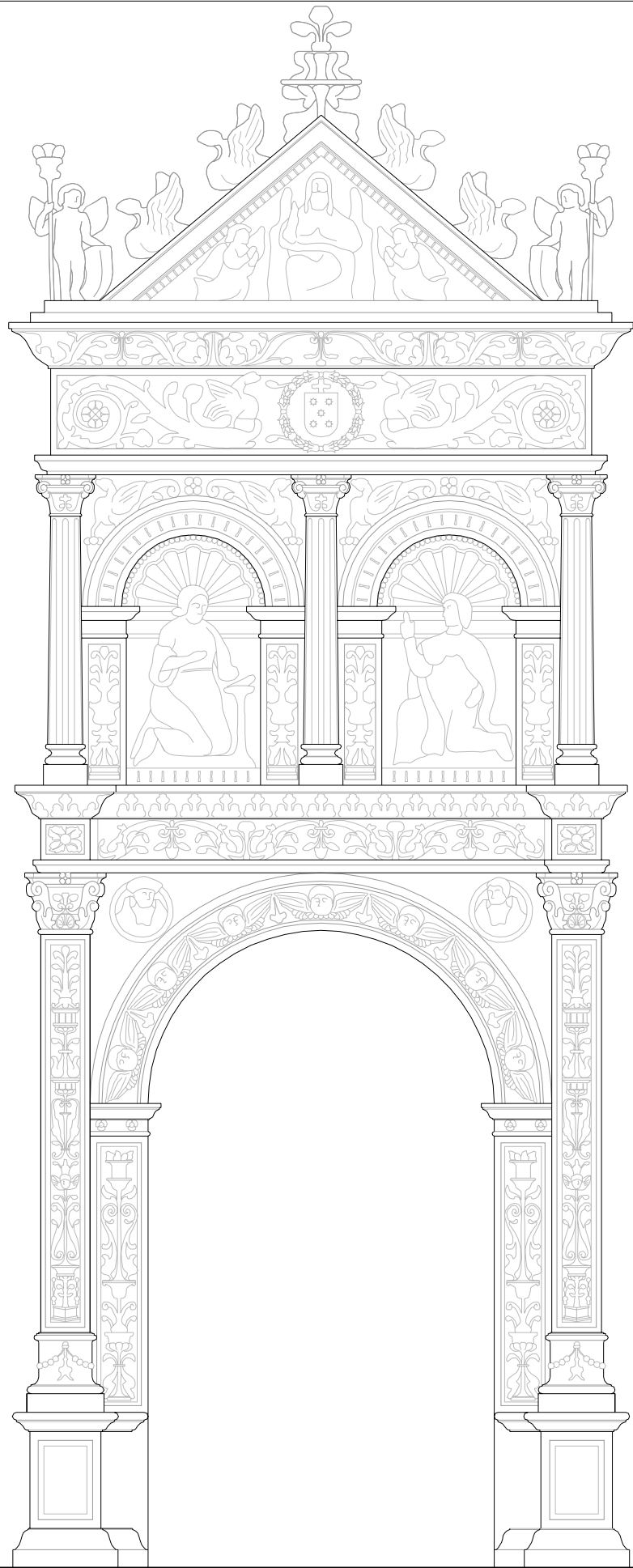

PUERTA DEL CLAUSTRO

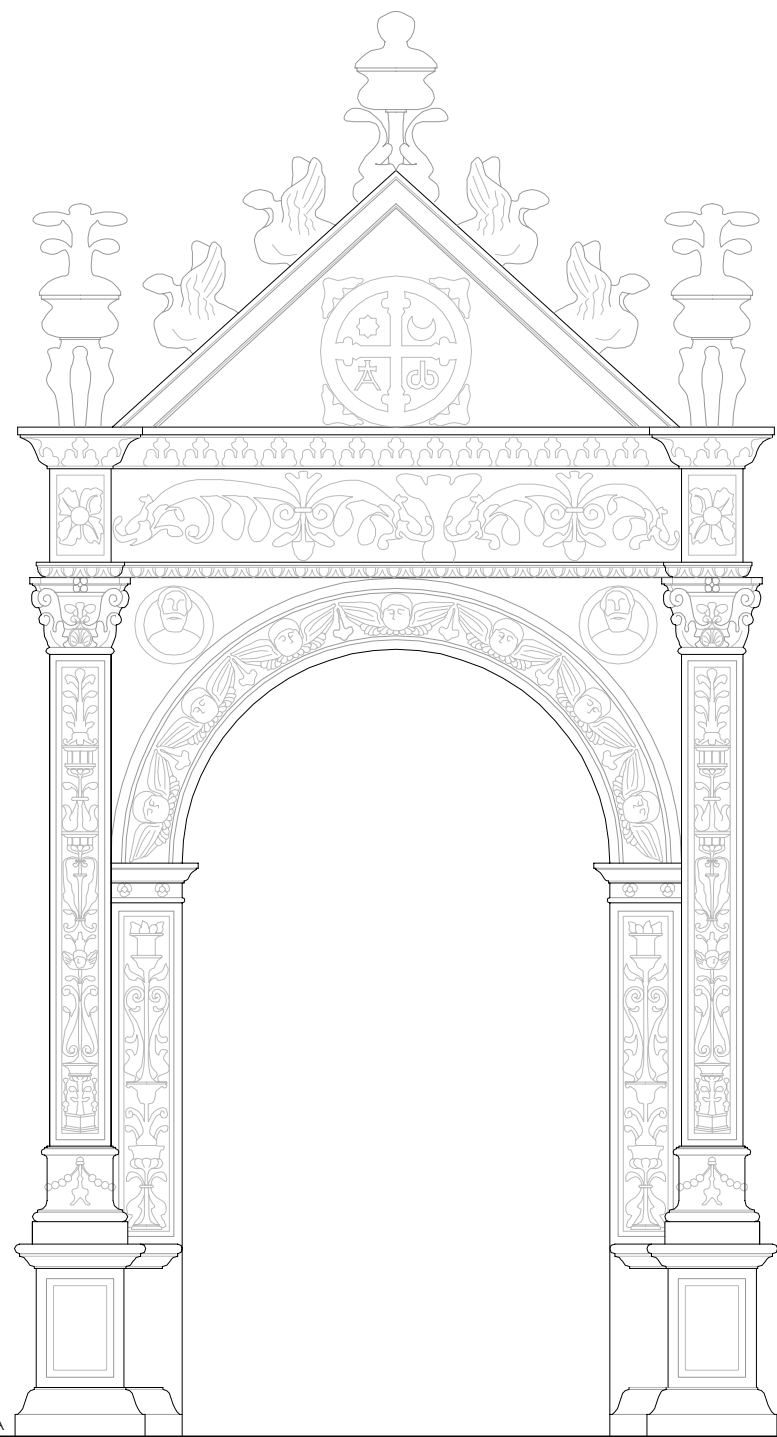

PUERTA DE LA CRIPTA

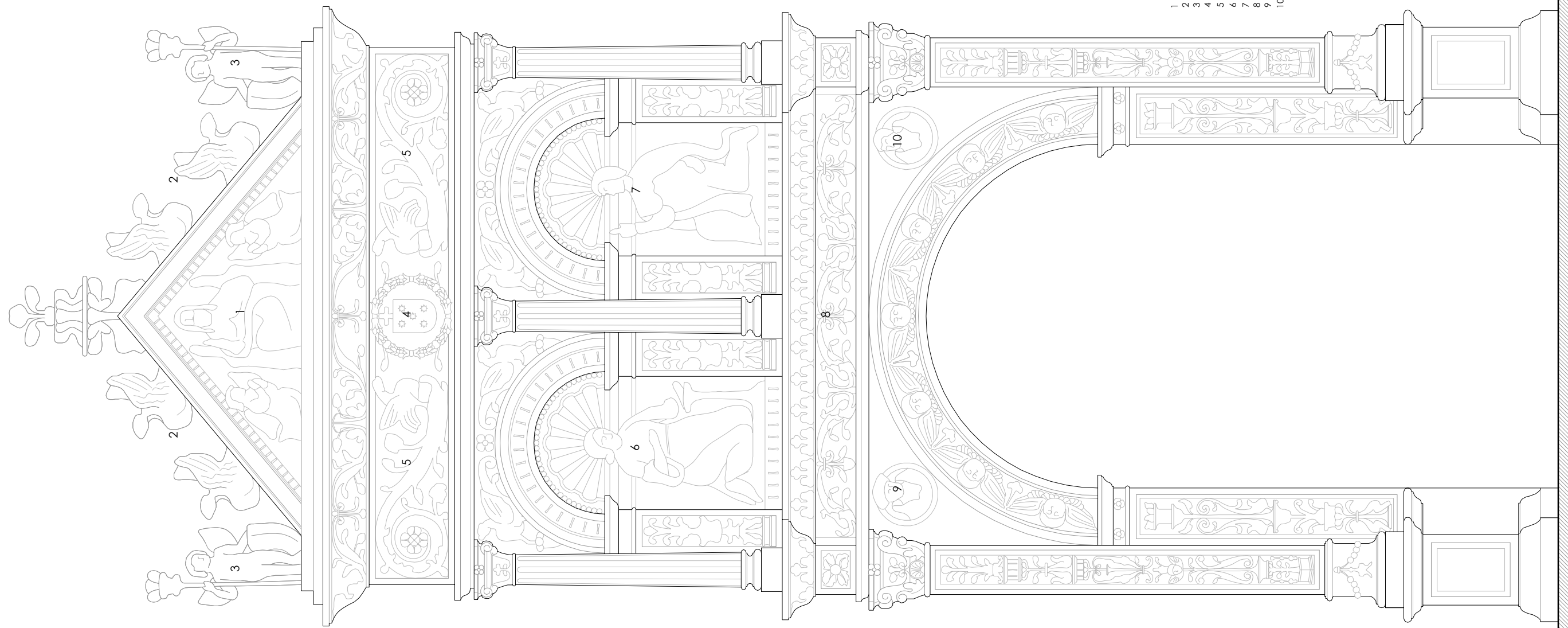

- | | | | | |
|----|-------------------|---------------------|------------------------|---------------------|
| 1 | DIOS PADRE | PUERTA DEL CLAUSTRO | PUERTA DE LA SACRISTÍA | PUERTA DE LA CRIPTA |
| 2 | GRIFOS | GRIFOS | SANTIAGO | CRUZ GRIEGA |
| 3 | TENANTE | TENANTE | GRIFOS | |
| 4 | ESCUDO DE FONSECA | ESCUDO DE FONSECA | TENANTE | |
| 5 | AGUILA Y DELFIN | AGUILA Y DELFIN | ESCUDO DE FONSECA | |
| 6 | VIRGEN MARIA | VIRGEN MARIA | GRIFOS | |
| 7 | ÁNGEL GABRIEL | SANTIAGO | SANTIAGO | |
| 8 | DELFINES | SAN ILDEFONSO | DELFINES | SAN PEDRO |
| 9 | ALFONSO III | VALOR | VALOR | SAN PABLO |
| 10 | ALFONSO II | SABIDURÍA | SABIDURÍA | |

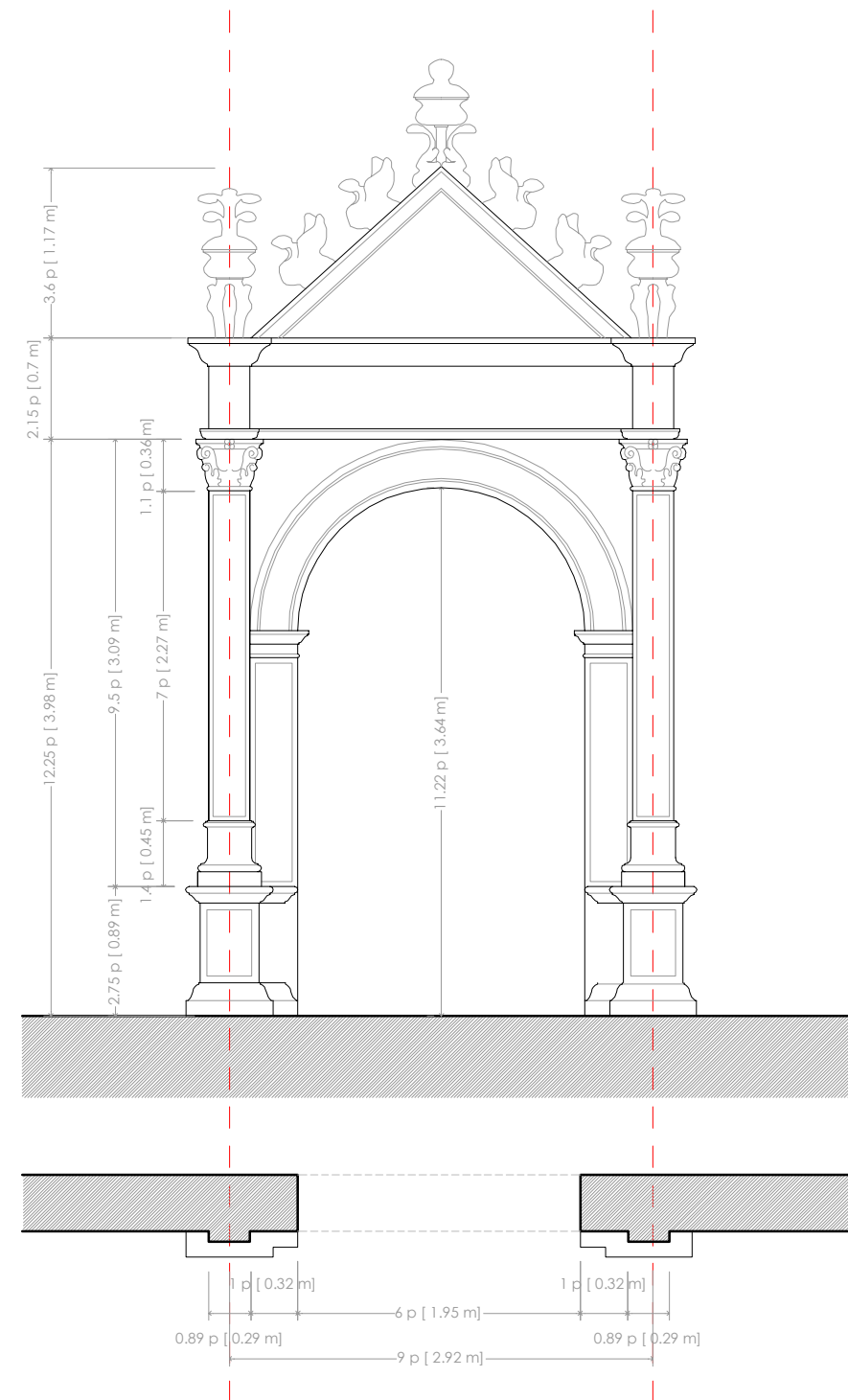
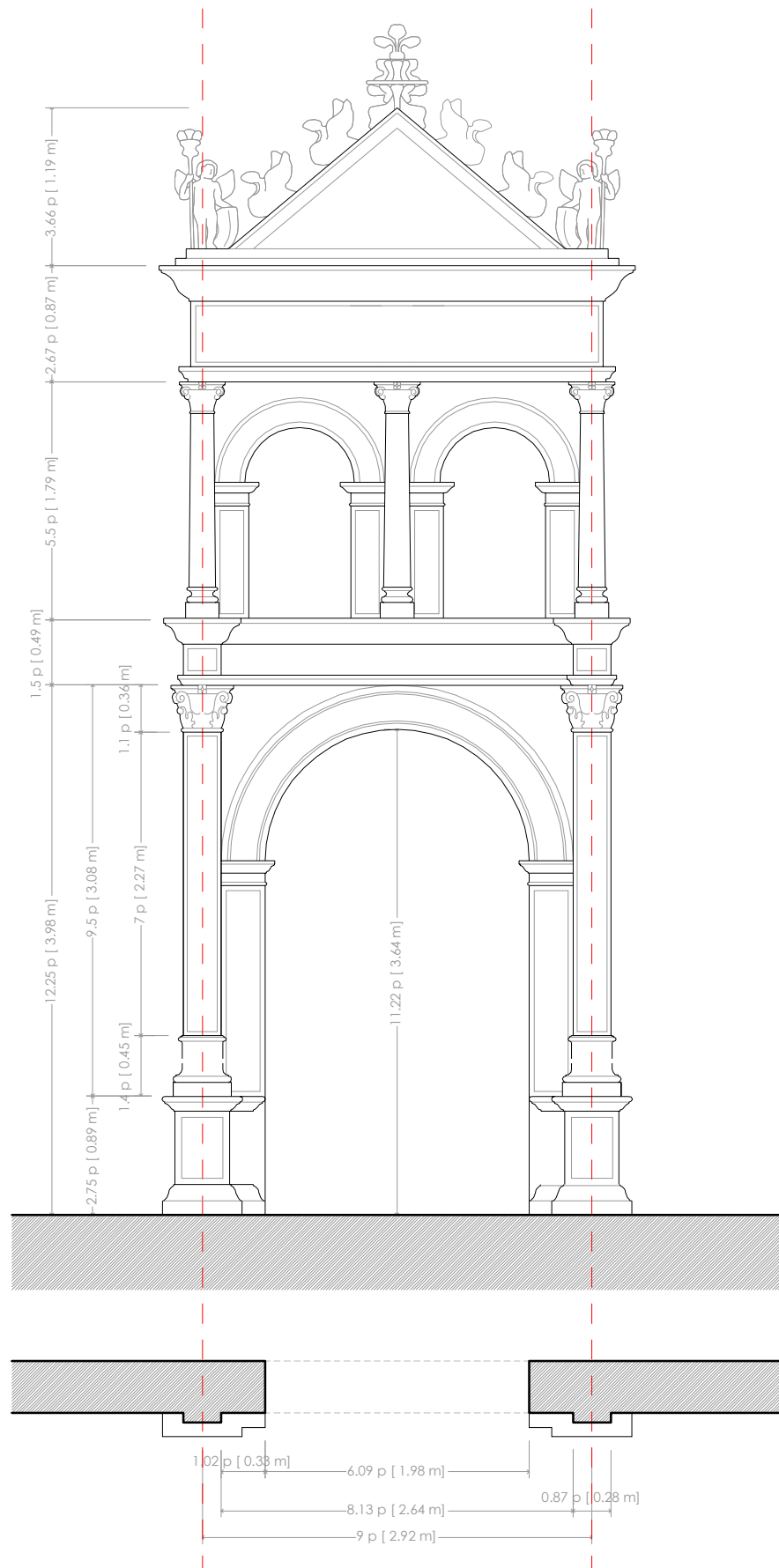

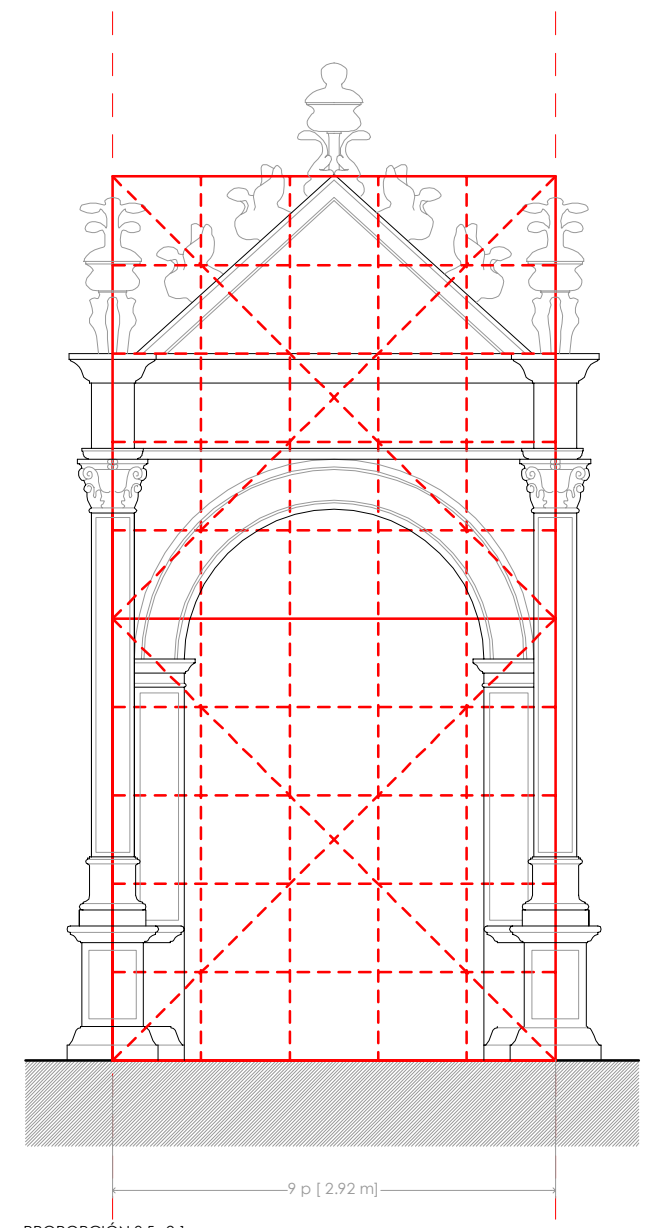
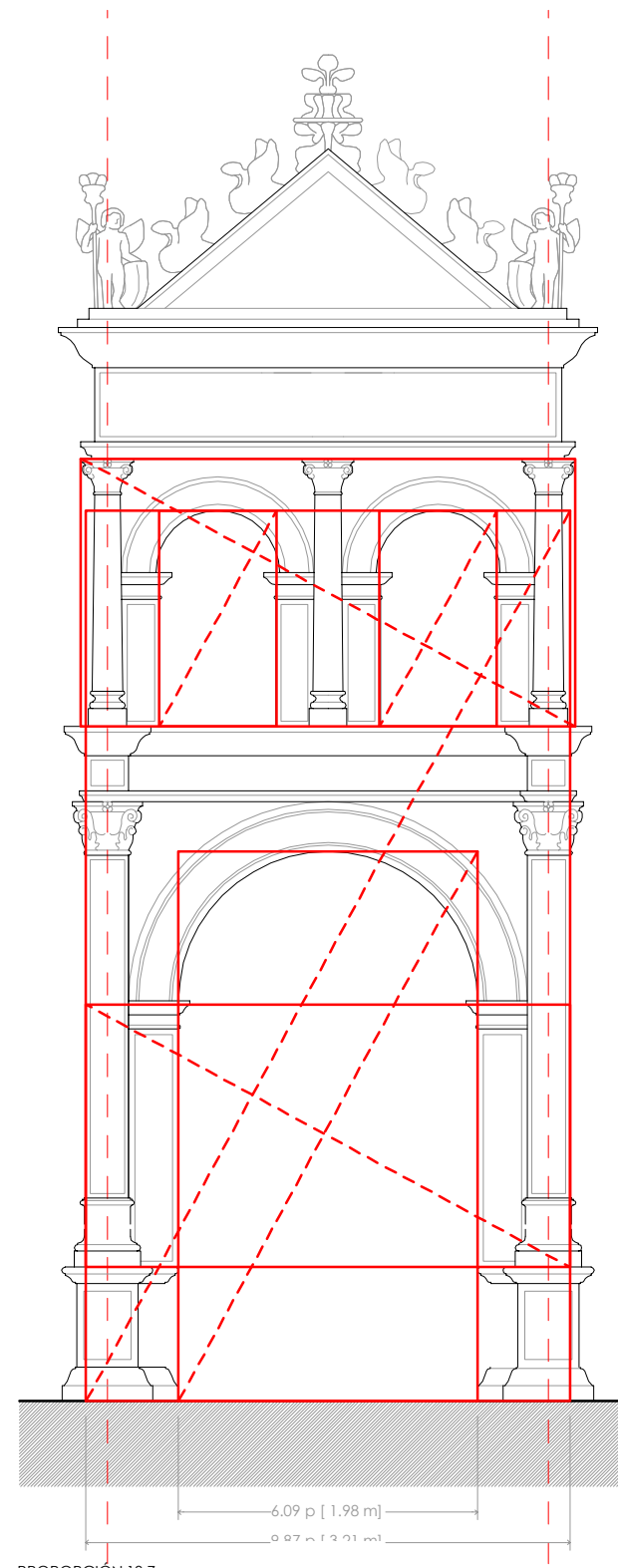
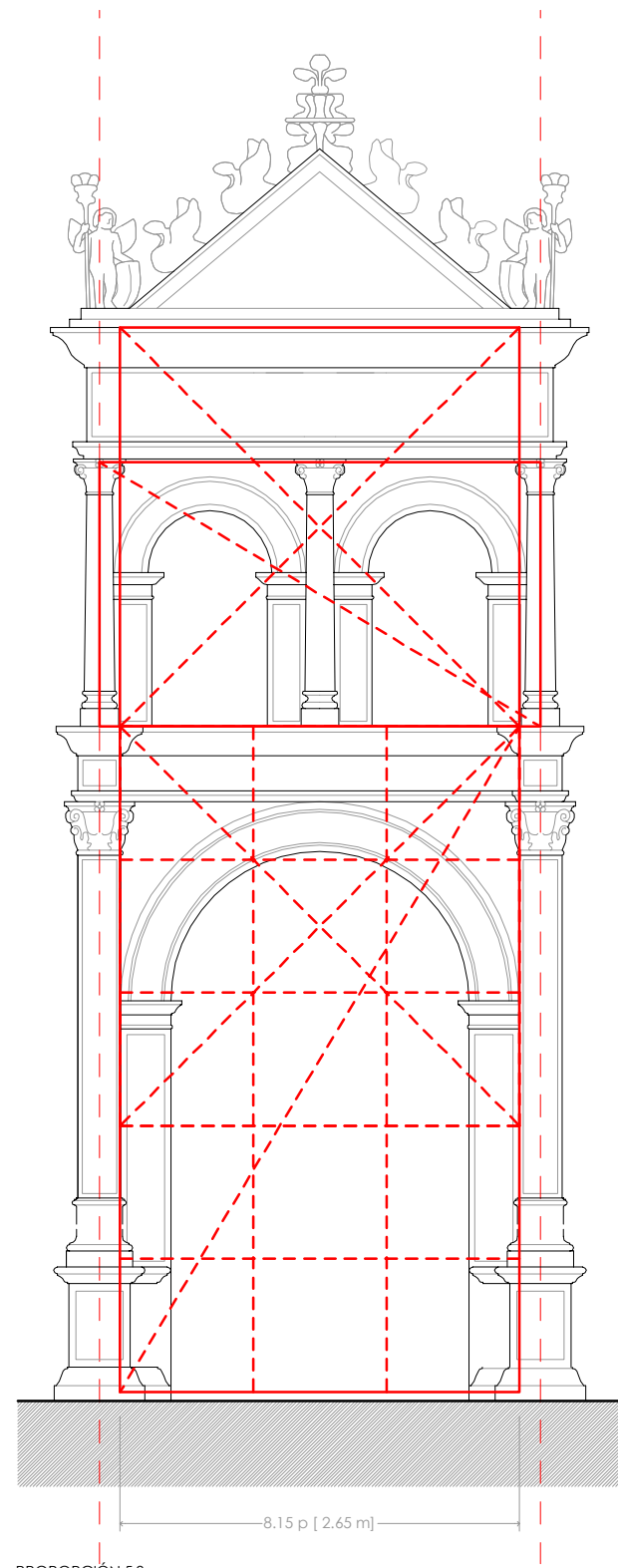
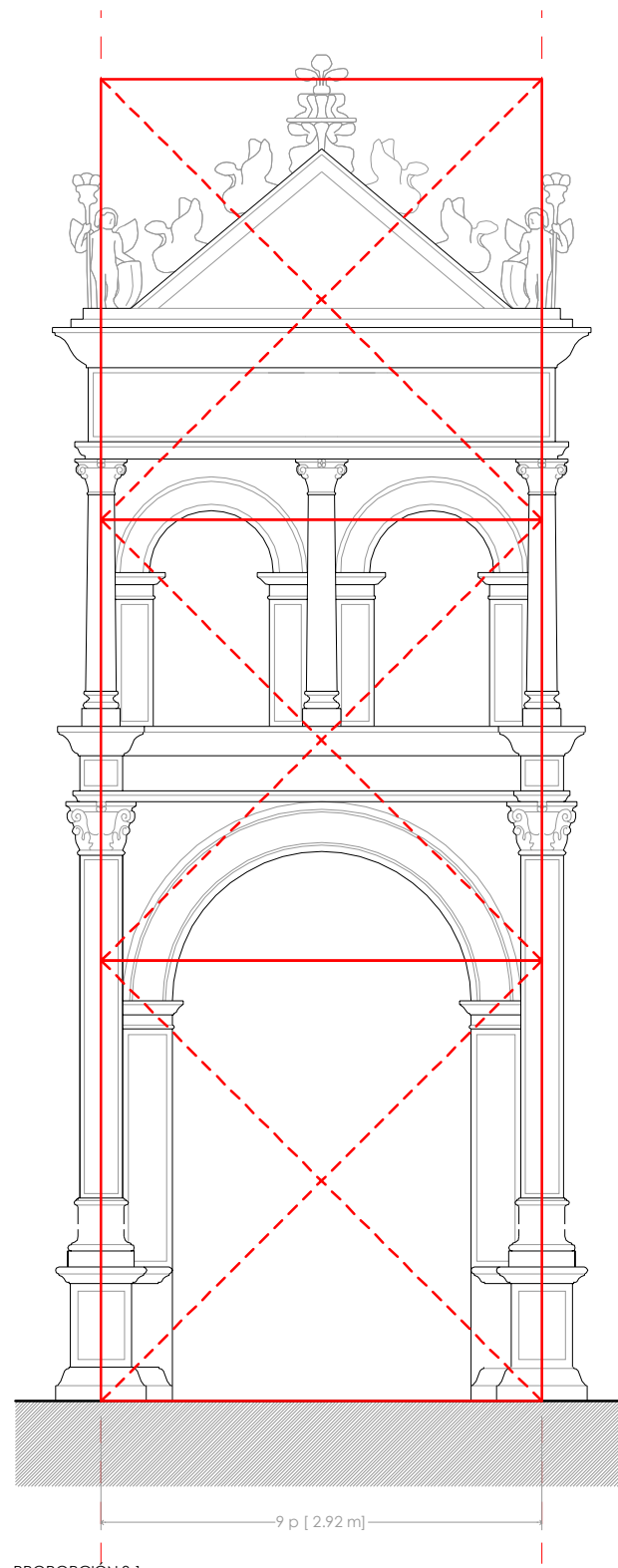

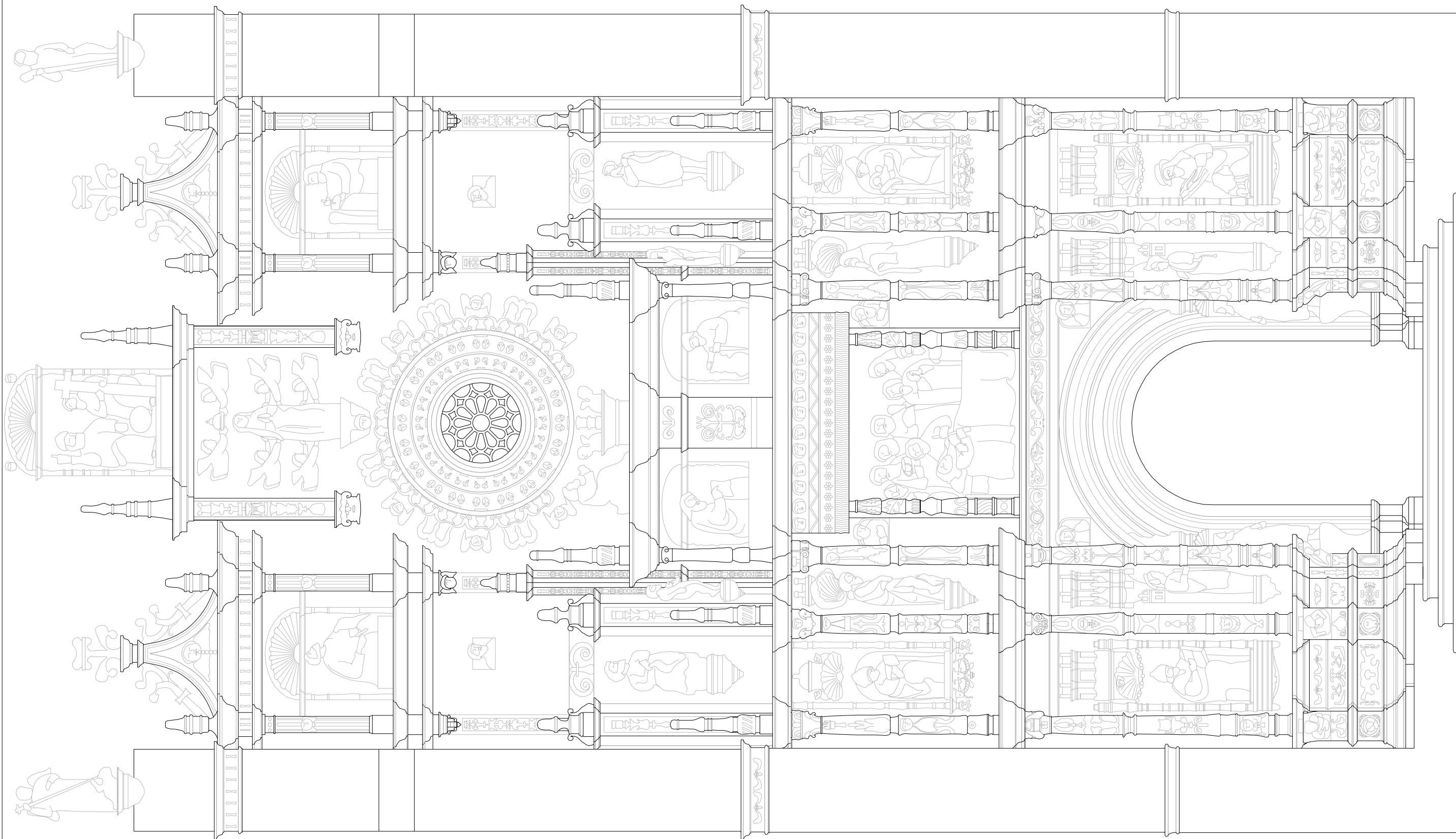

FACHADAS

FACHADA DE LA IGLESIA DE STA Mª LA MAYOR EN PONTEVEDRA

DETALLE

e: 1/50
 1 pie: 27.50cm

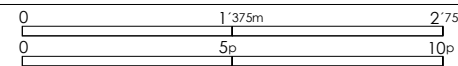

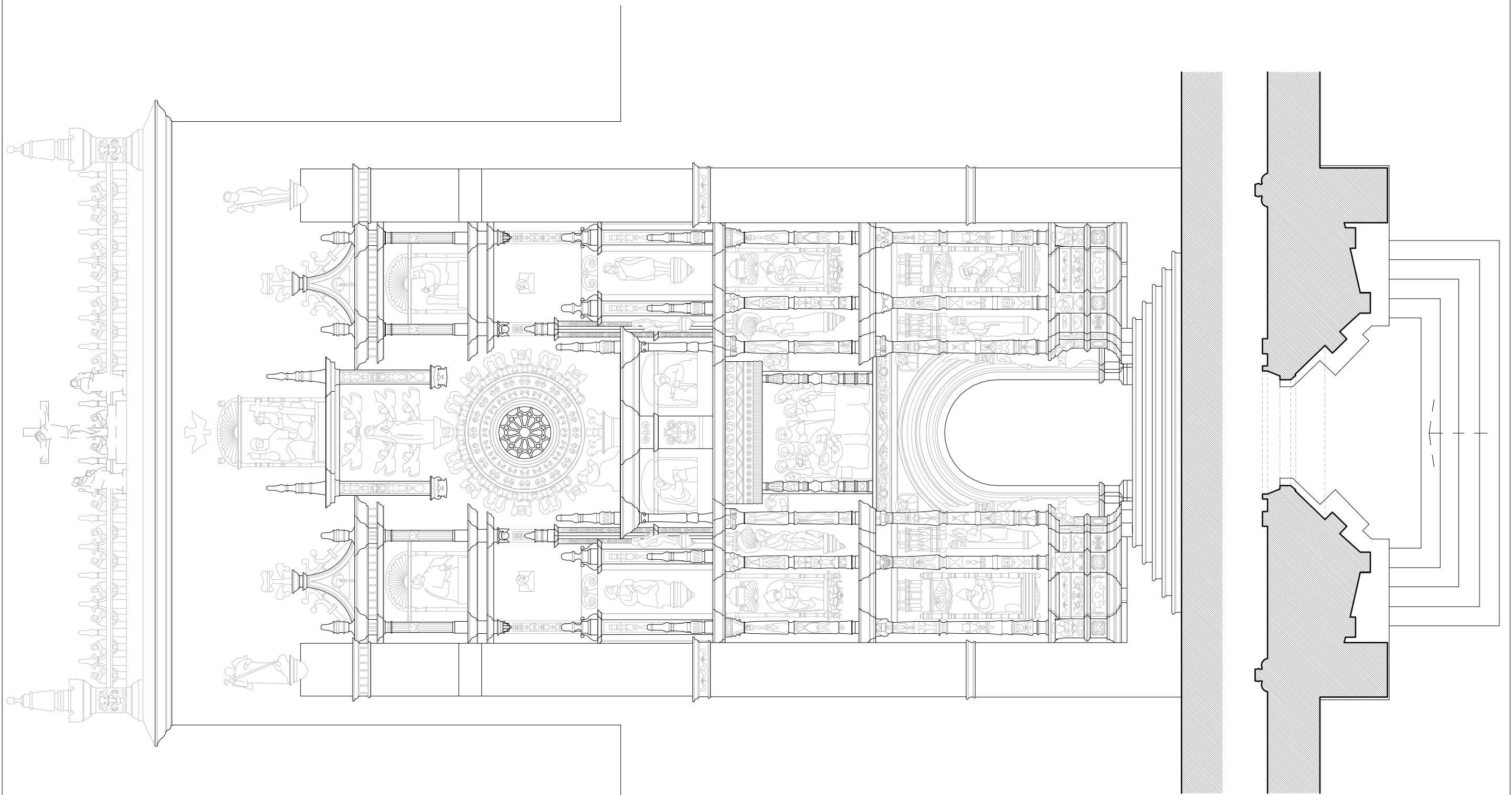

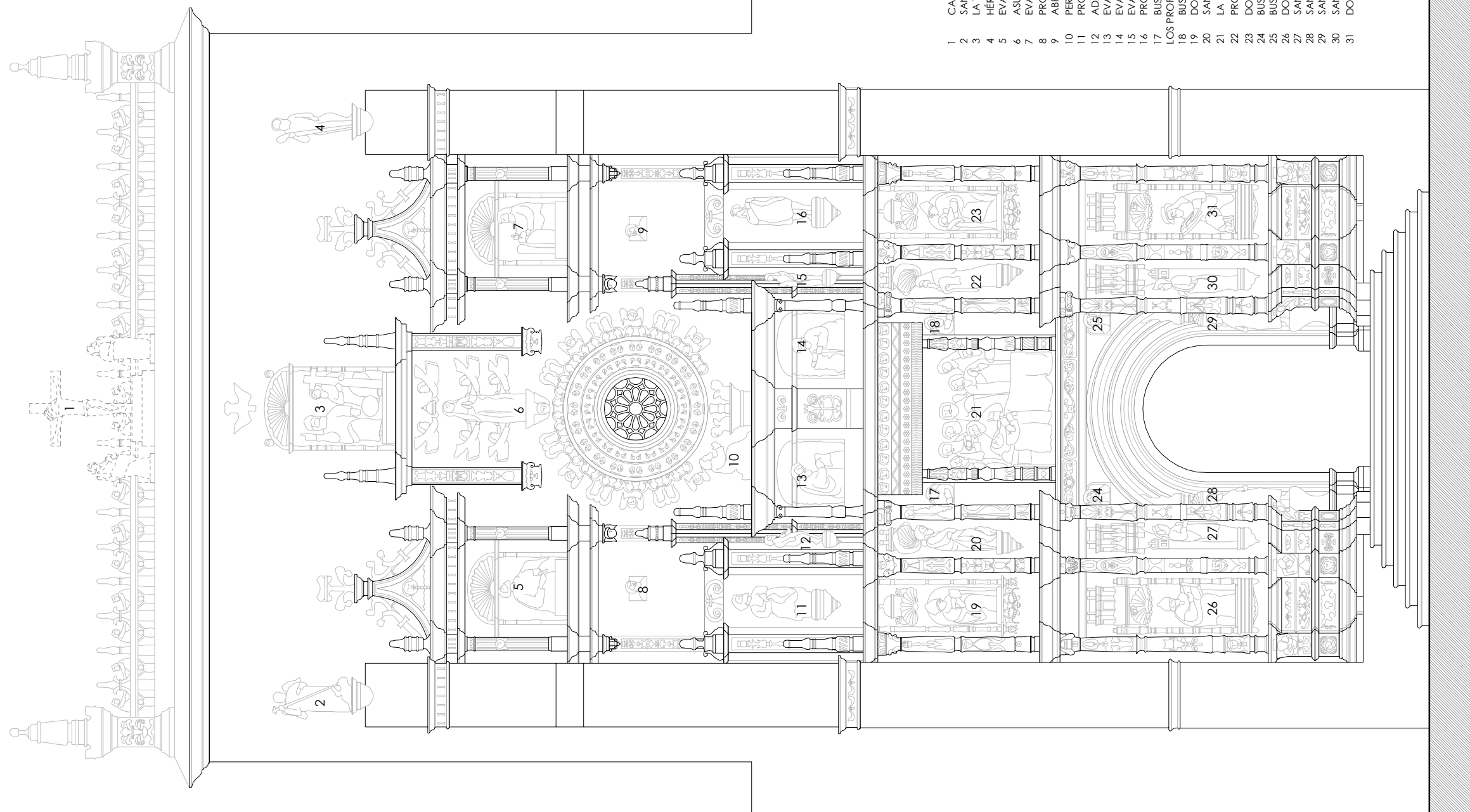

- 1 CALVARIO. CORONAMIENTO DE LA FACHADA
- 2 SAN MIGUEL (PATRONO DE LOS MAREANTES)
- 3 LA TRINIDAD
- 4 HÉRCULES-TEUCRO (PATRÓN HUMANÍSTICO ANCESTRAL DE LOS MAREANTES)
- 5 EVANGELISTA: SAN JUAN
- 6 ASUNCIÓN Y CORONACIÓN DE LA VIRGEN
- 7 EVANGELISTA: SAN MATEO
- 8 PROFETA: ISAÍAS
- 9 ABRAHAM
- 10 PERSONA JE ORANTE (SANTO TOMÁS, MELCHISEDECH O SANTIAGO)
- 11 PROFETA: EZEQUIEL
- 12 ADÁN
- 13 EVANGELISTA: SAN LUCAS
- 14 EVANGELISTA: SAN MARCOS
- 15 EVA
- 16 PROFETA: DANIEL
- 17 BUSTO: ISAÍAS (DESPLAZADO POR SAN JUAN BAUTISTA DEL LUGAR QUE OCUPAN LOS PROFETAS)
- 18 BUSTO: ABRAHAM O DAVID
- 19 DOCTOR: SAN AMBROSIO
- 20 SAN JUAN BAUTISTA
- 21 LA DORMICIÓN DE LA VIRGEN
- 22 PROFETA: JEREMÍAS
- 23 DOCTOR: SAN AGUSTÍN
- 24 BUSTO: CARLOS V
- 25 BUSTO: FELIPE II (EN PROYECTO IBA SU MADRE LA EMPERATRIZ ISABEL)
- 26 DOCTOR: SAN GREGORIO MAGNO
- 27 SANTA CATALINA
- 28 SAN PABLO
- 29 SAN PEDRO
- 30 SANTA BÁRBARA
- 31 DOCTOR: SAN JERÓNIMO

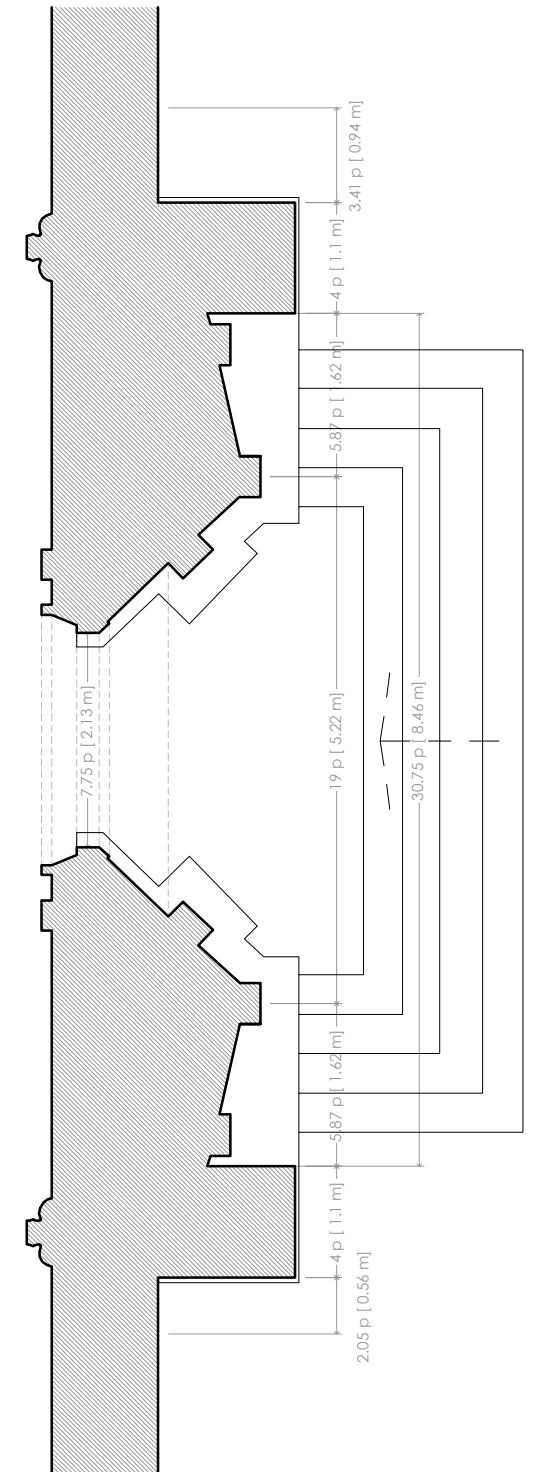
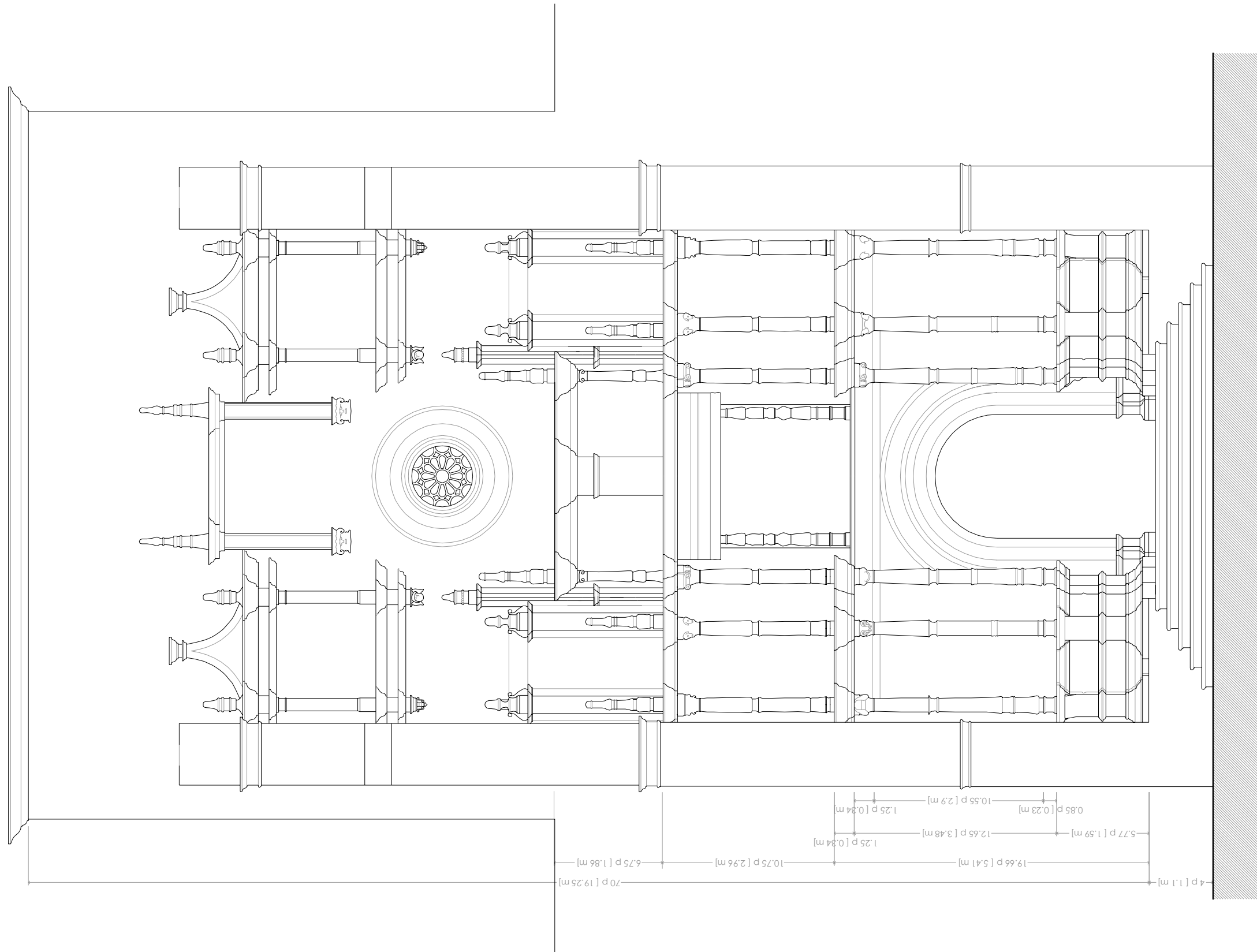

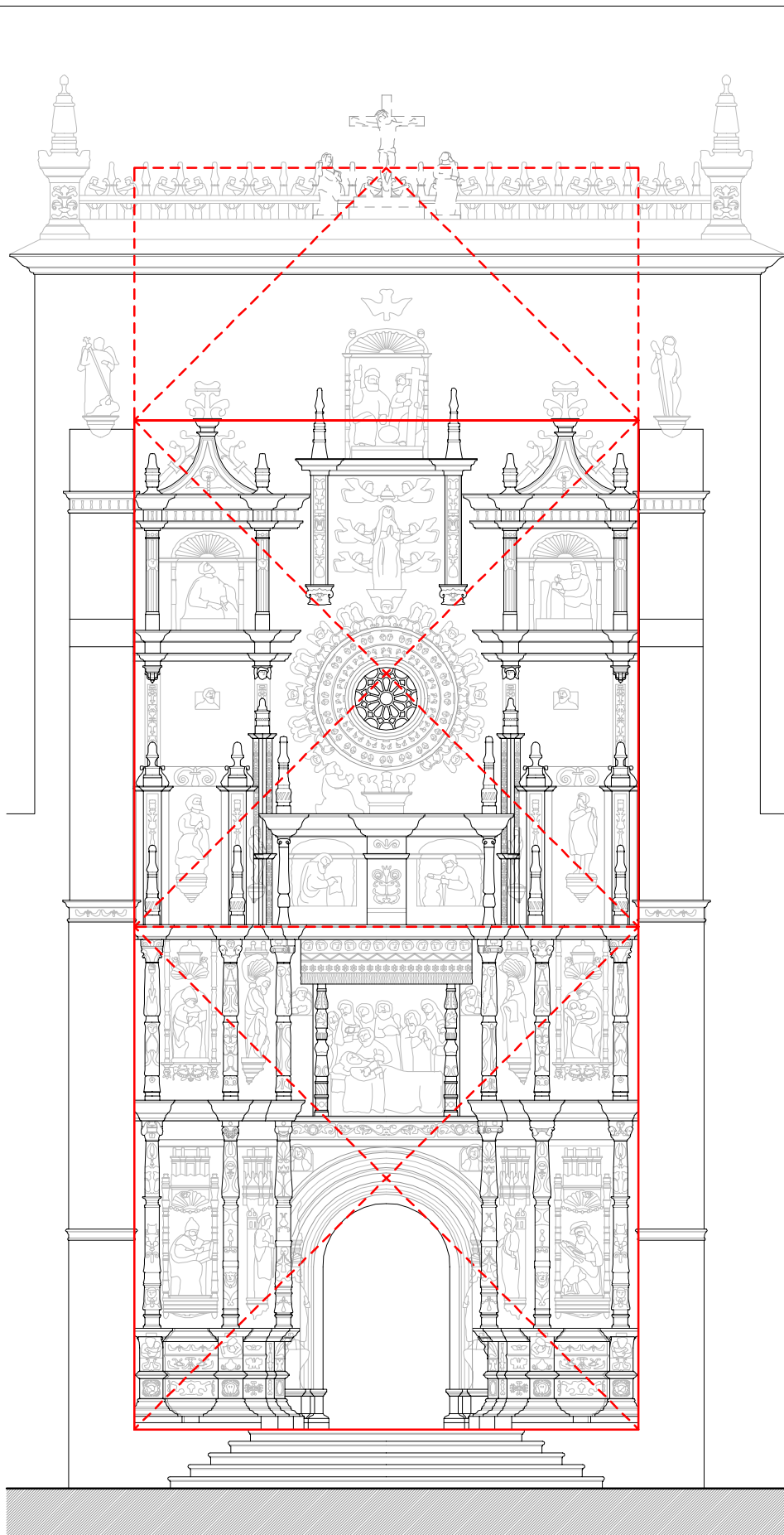

PROPORCIÓN 1:2.52

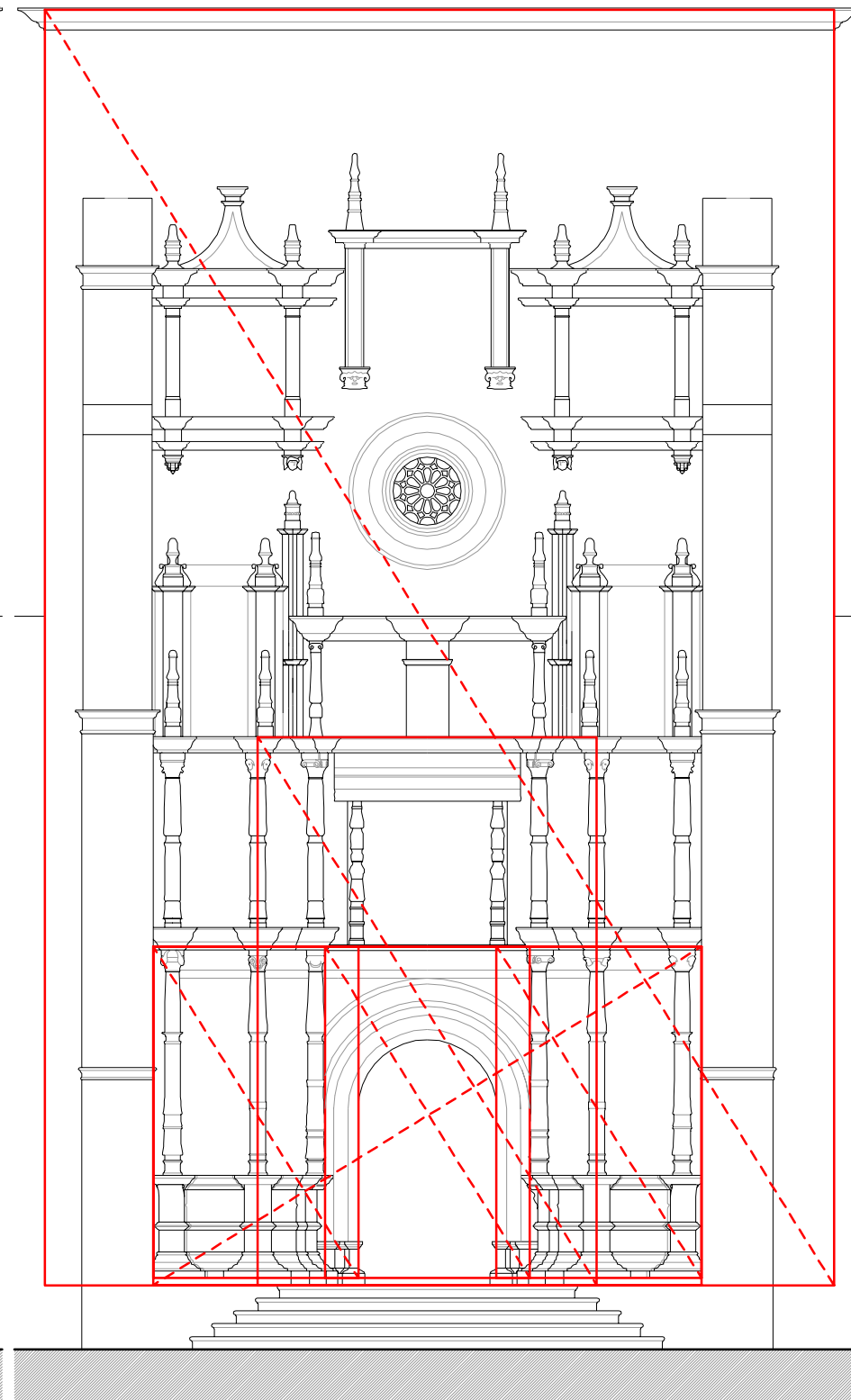

PROPORCIÓN ÁUREA

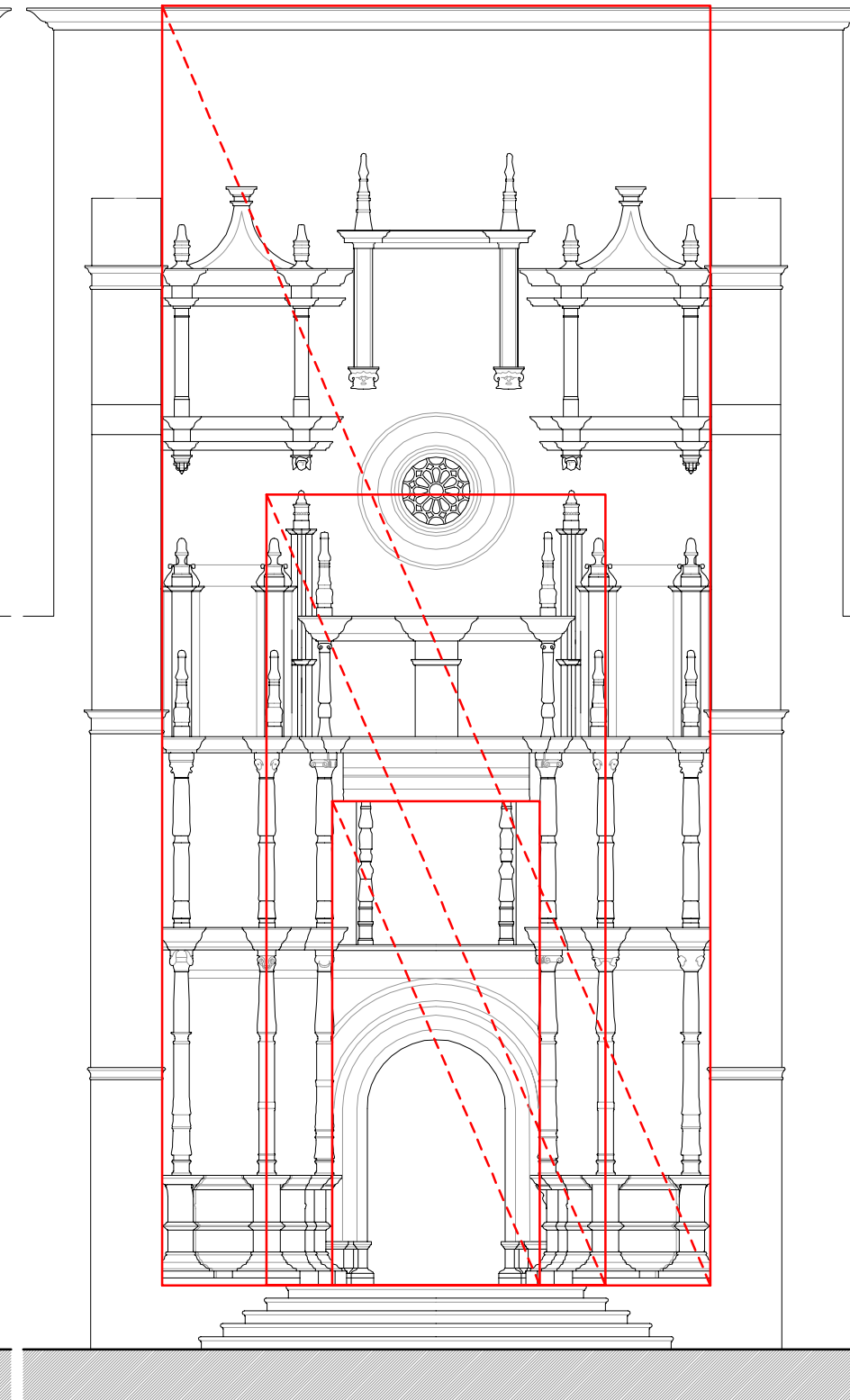

PROPORCIÓN 7:3

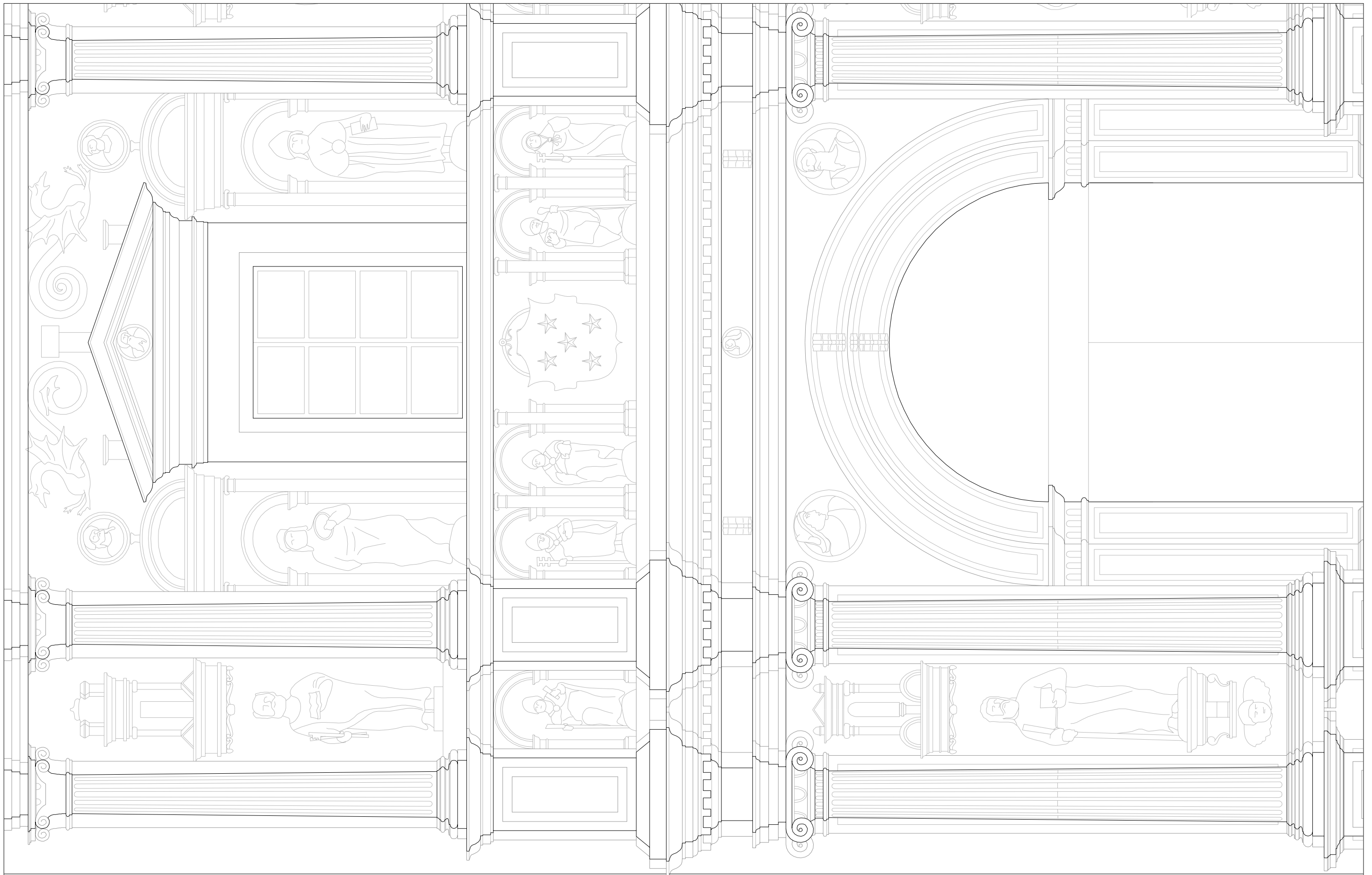

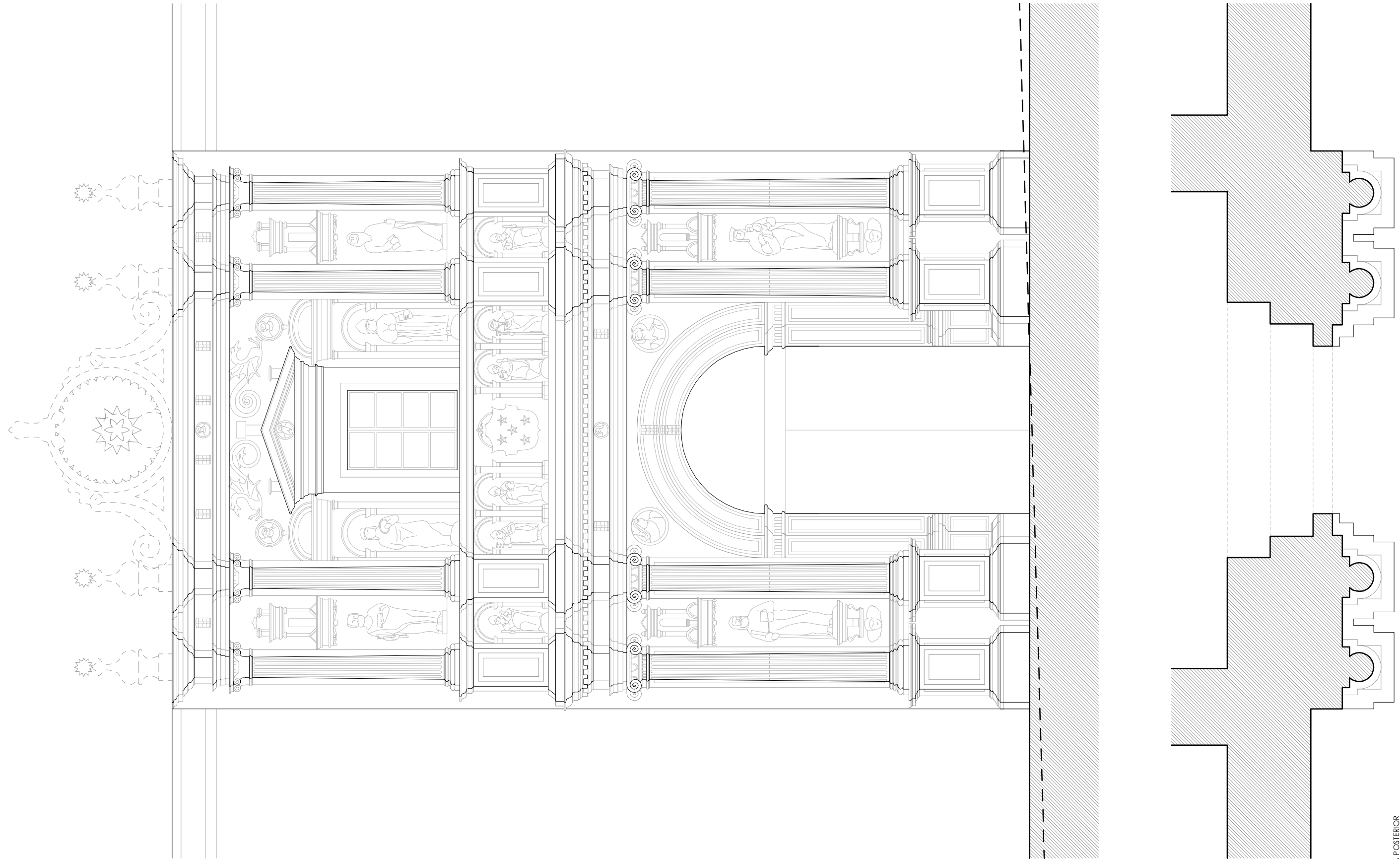

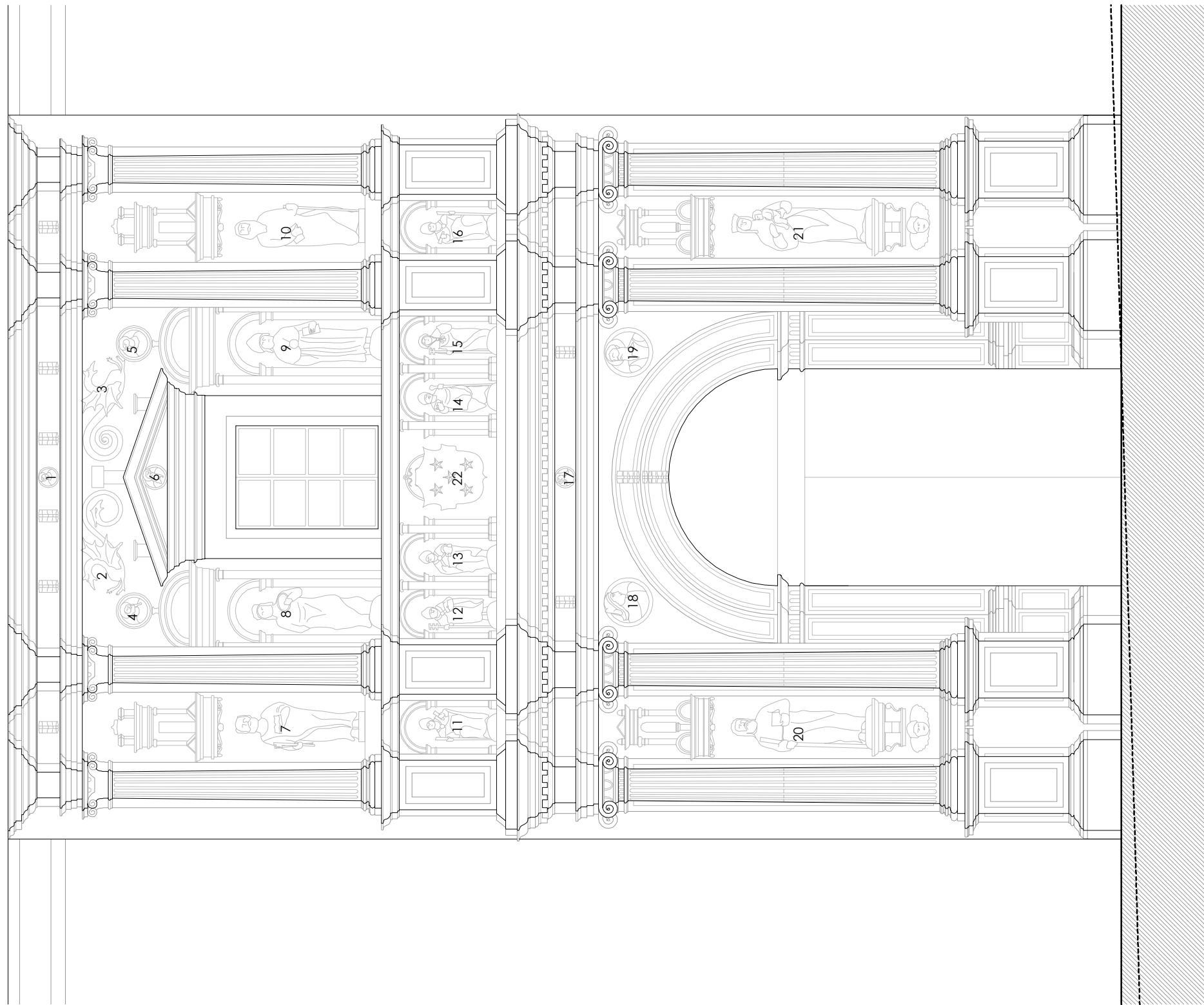

- | | | |
|----|----------------------------|---|
| 1 | HÉRCULES | (LA ASCENDENCIA CLÁSICA DE LA MONARQUÍA ESPAÑOLA, Y EN CIERTA MEDIDA, CON LA DE LOS FONSECA) |
| 2 | DRAGÓN | (GUARDIÁN) |
| 3 | DRAGÓN | (PRINCIPE HÚNGARO QUE ORIGINÓ EL LINAJE DE LOS FONSECA) |
| 4 | PIERRES | (PRINCIPE HÚNGARO QUE ORIGINÓ EL LINAJE DE LOS FONSECA) |
| 5 | PAIAN | (PATRÓN DE LA CIUDAD, APARECE INSCRITO EN UN FRONTÓN TRIANGULAR, SÍMBOLO DE LA TRINIDAD, POR LO TANTO, CASI DIVINIZADO) |
| 6 | SANTIAGO EL MAYOR | (PATRÓN DE LOS COLEGIOS MAYORES DE ESPAÑA) |
| 7 | SAN PEDRO | (PATRÓN DE LA CIUDAD, APARECE INSCRITO EN UN FRONTÓN TRIANGULAR, SÍMBOLO DE LA TRINIDAD, POR LO TANTO, CASI DIVINIZADO) |
| 8 | SANTA CATALINA | (PATRONA DE LA ABUELA DEL FUNDADOR) |
| 9 | SAN ILDEFONSO | (PATRÓN DEL FUNDADOR) |
| 10 | SAN PABLO | (PATRÓN DE LOS COLEGIOS MAYORES DE ESPAÑA) |
| 11 | DOCTOR: SAN ISIDORO | |
| 12 | DOCTOR: SAN GREGORIO MAGNO | |
| 13 | DOCTOR: SAN AMBROSIO | |
| 14 | DOCTOR: SAN AGUSTÍN | |
| 15 | DOCTOR: SAN GERÓNIMO | |
| 16 | DOCTOR: SAN LEANDRO | |
| 17 | LUCRECIA | |
| 18 | ESCIPIÓN | (UNIFICA A ESCIPIÓN Y HELIOGÁBALO) |
| 19 | HELIOGÁBALO | (REPRESENTA LA MALDAD) |
| 20 | SANTIAGO ALFEO | (PATRÓN DEL COLEGIO) |
| 21 | VERGEN DE LOS PLACERES | (ESTA IMAGEN ES DEVOCIÓN PERSONAL DE ALONSO III) |
| 22 | ESCUUDO DE FONSECA | |

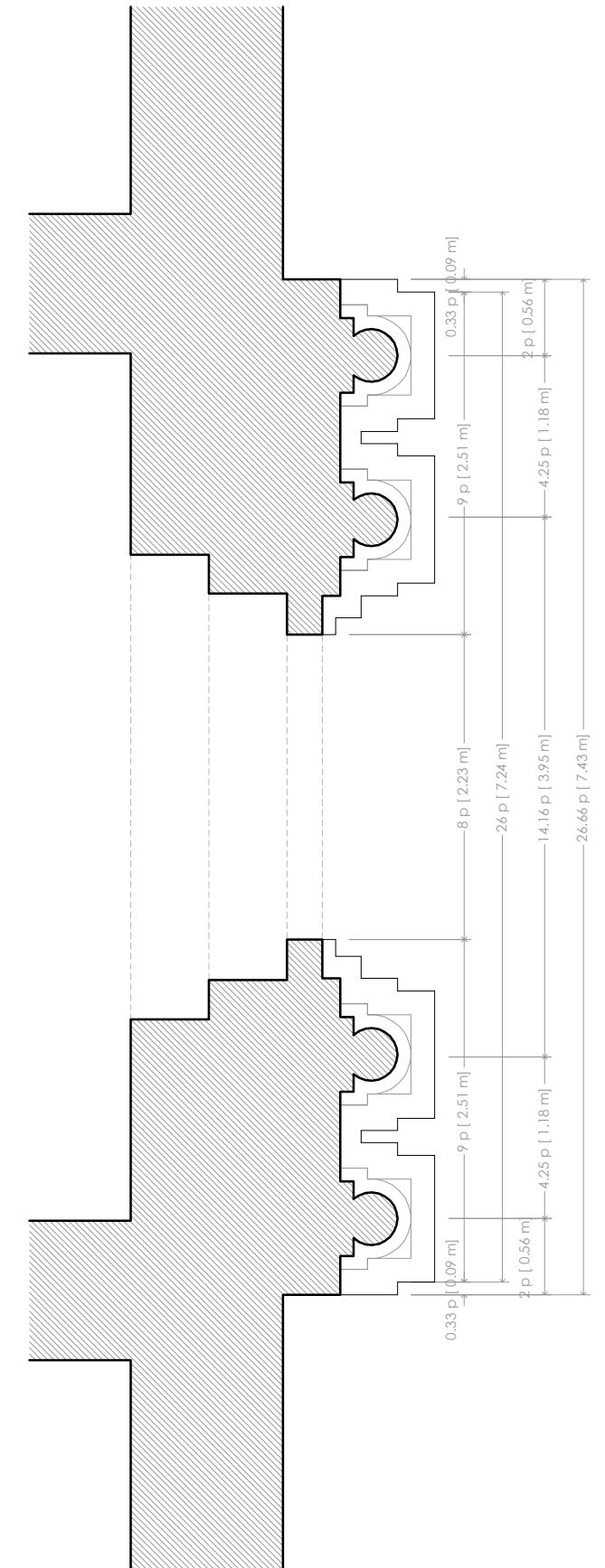
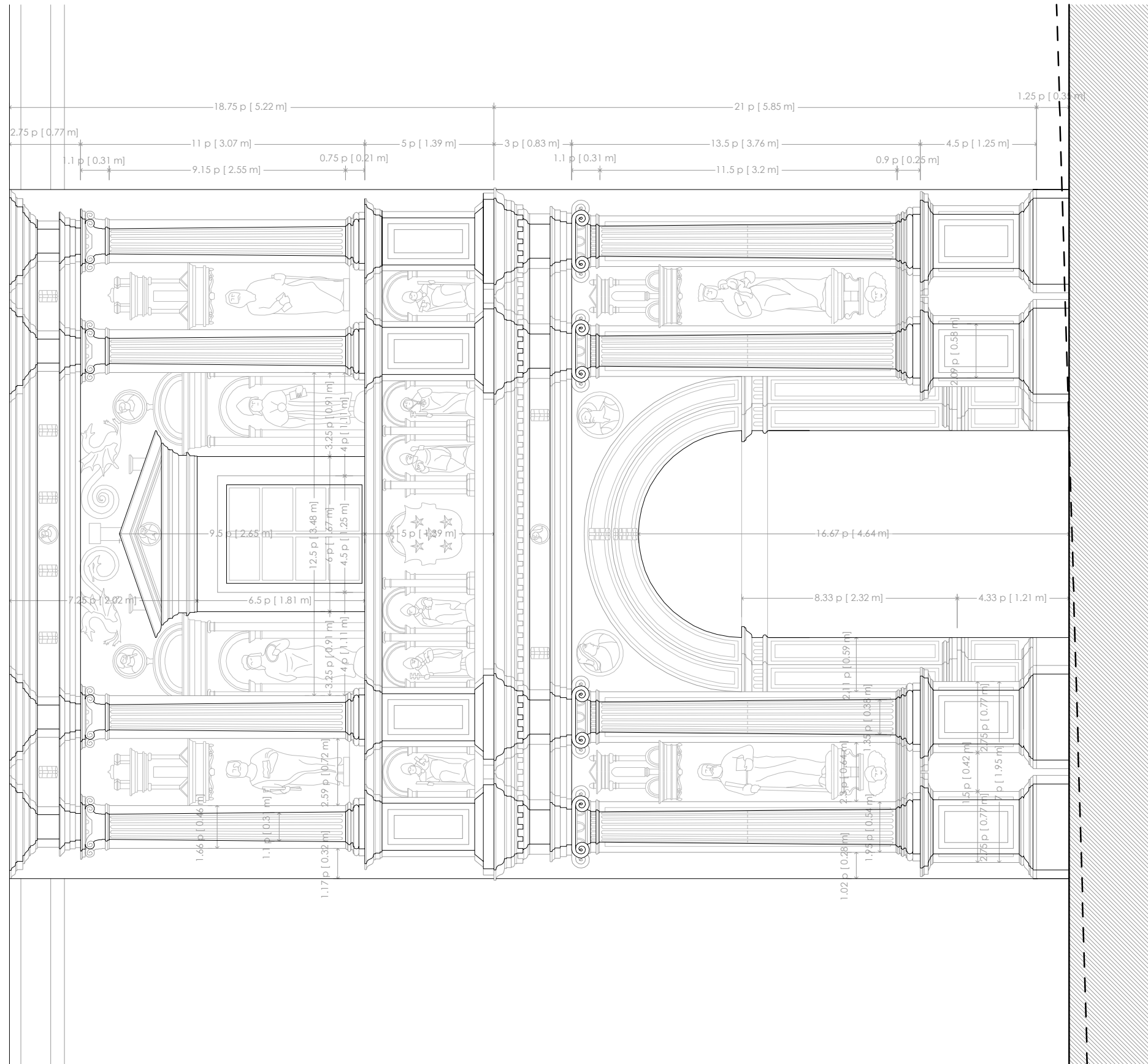

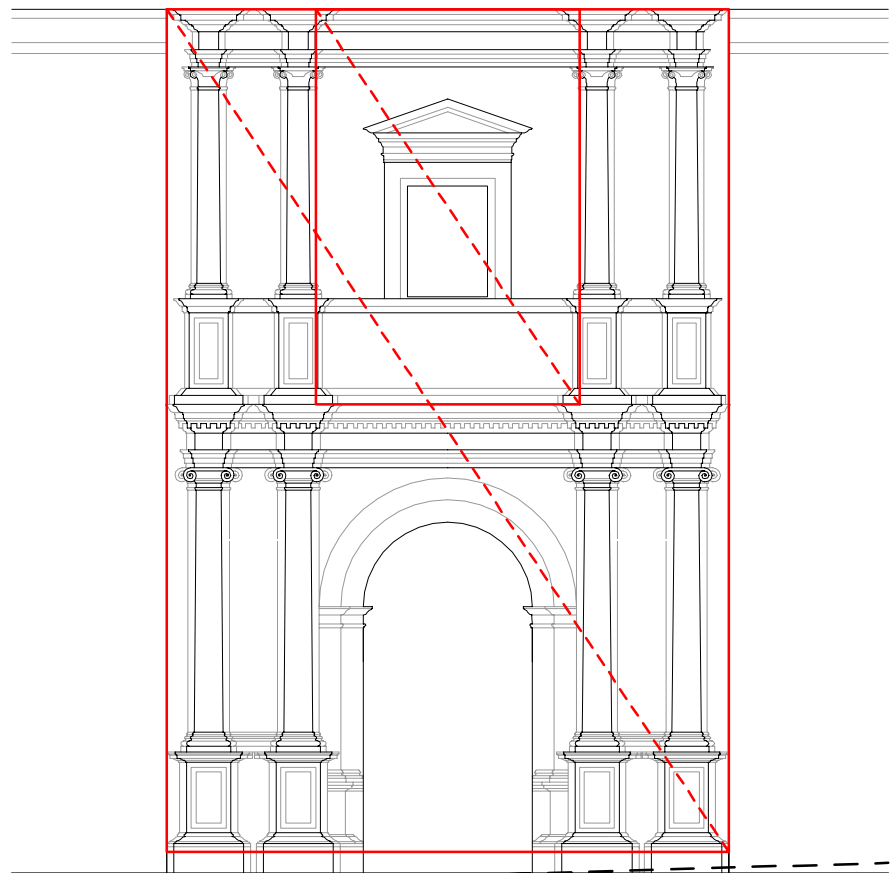

PROPORCIÓN 3:2

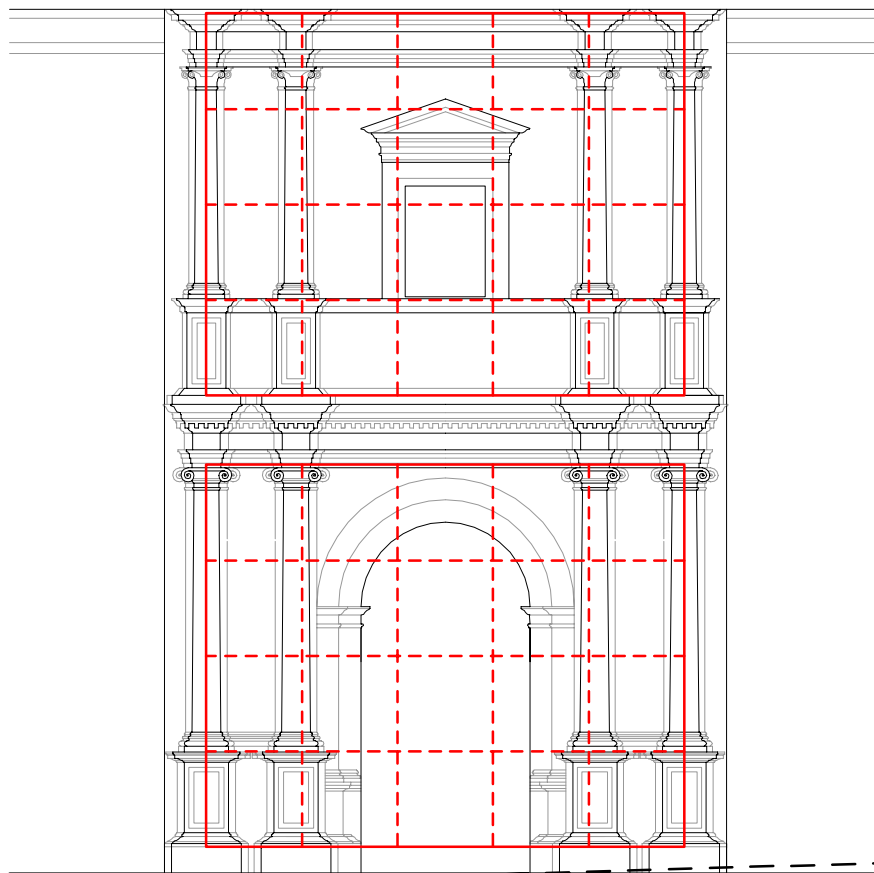

PROPORCIÓN 5:4

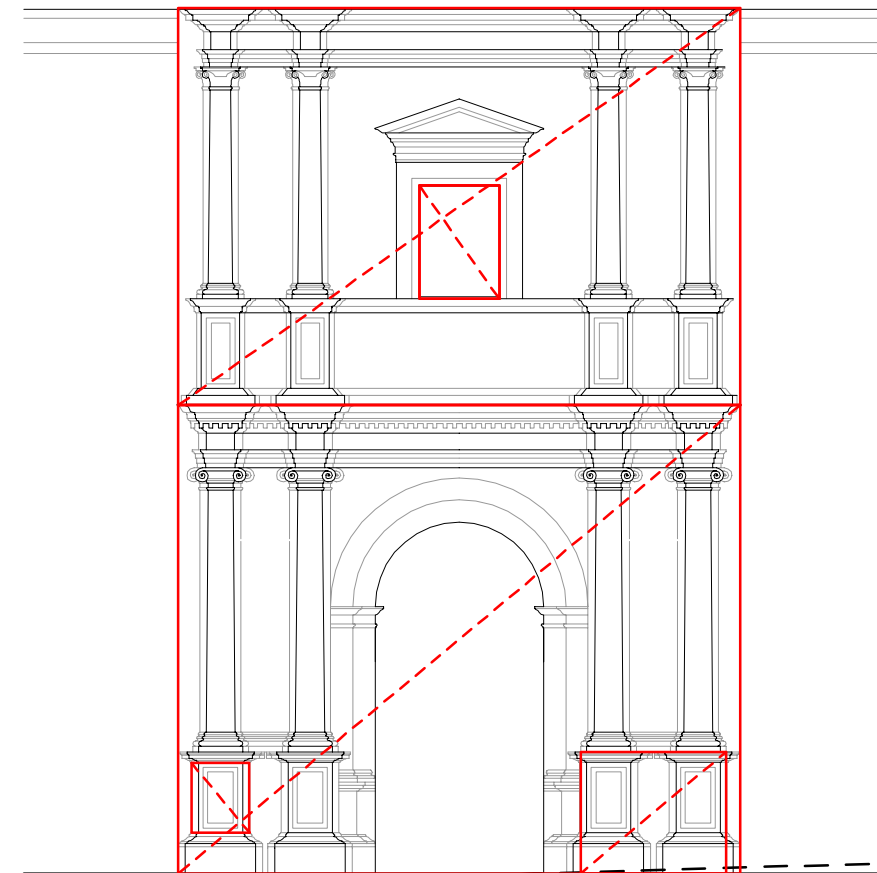

PROPORCIÓN PLANTA SUPERIOR $\sqrt{2}$
PROPORCIÓN PLANTA INFERIOR 6:5

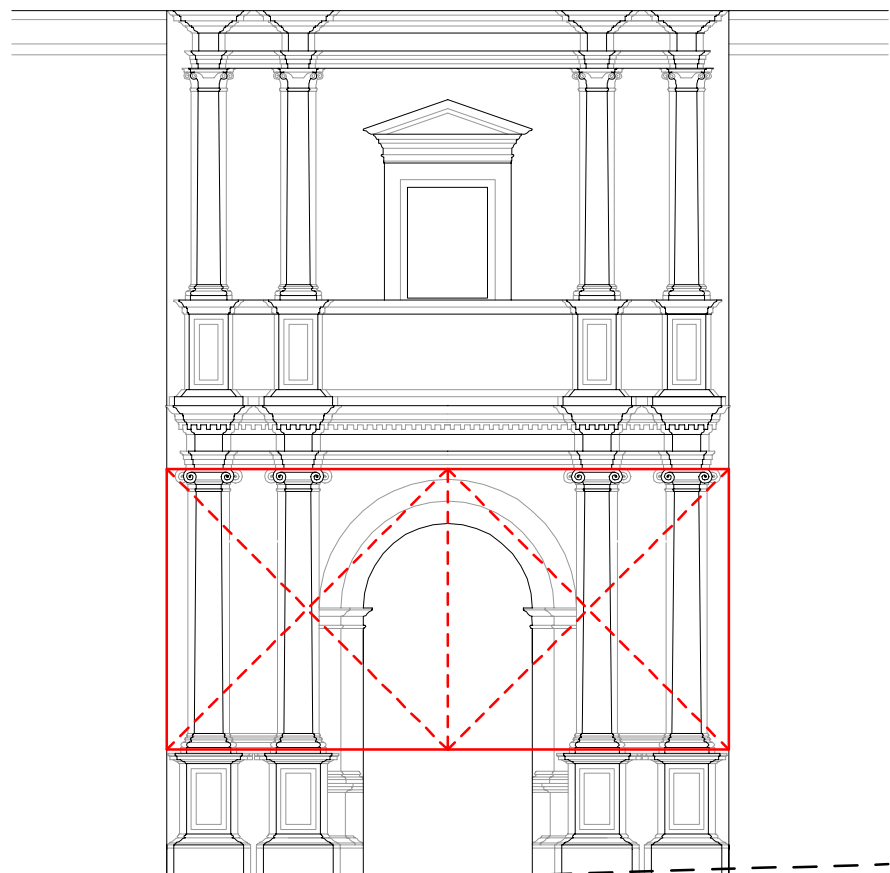

PROPORCIÓN 2:1

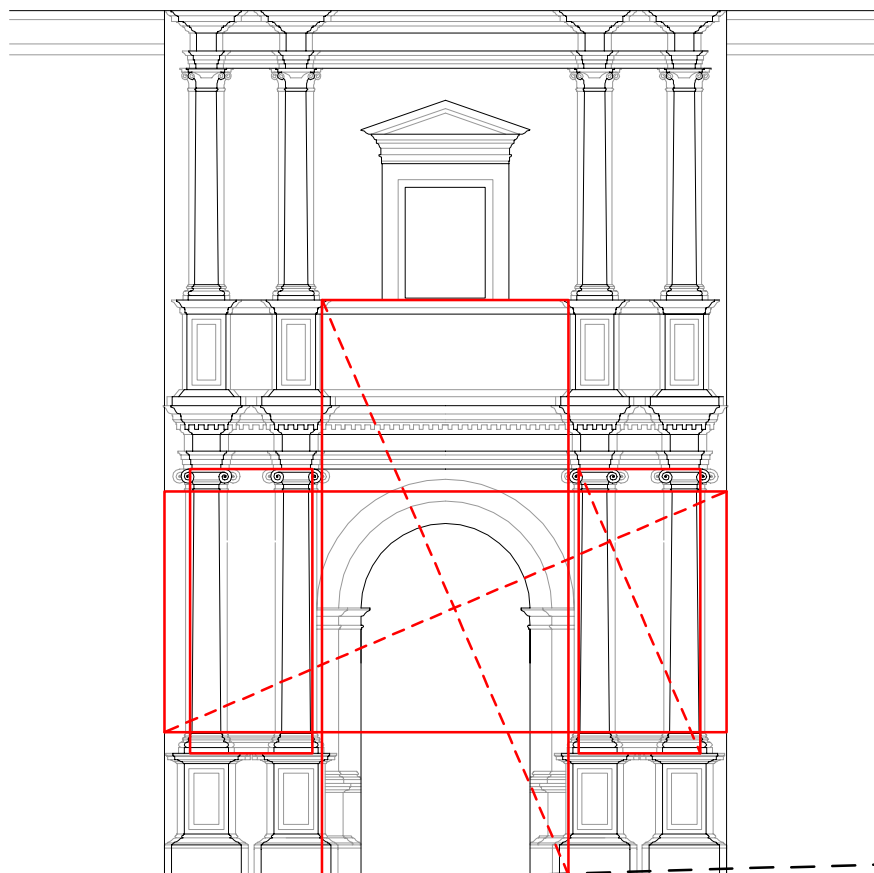

PROPORCIÓN 7:3

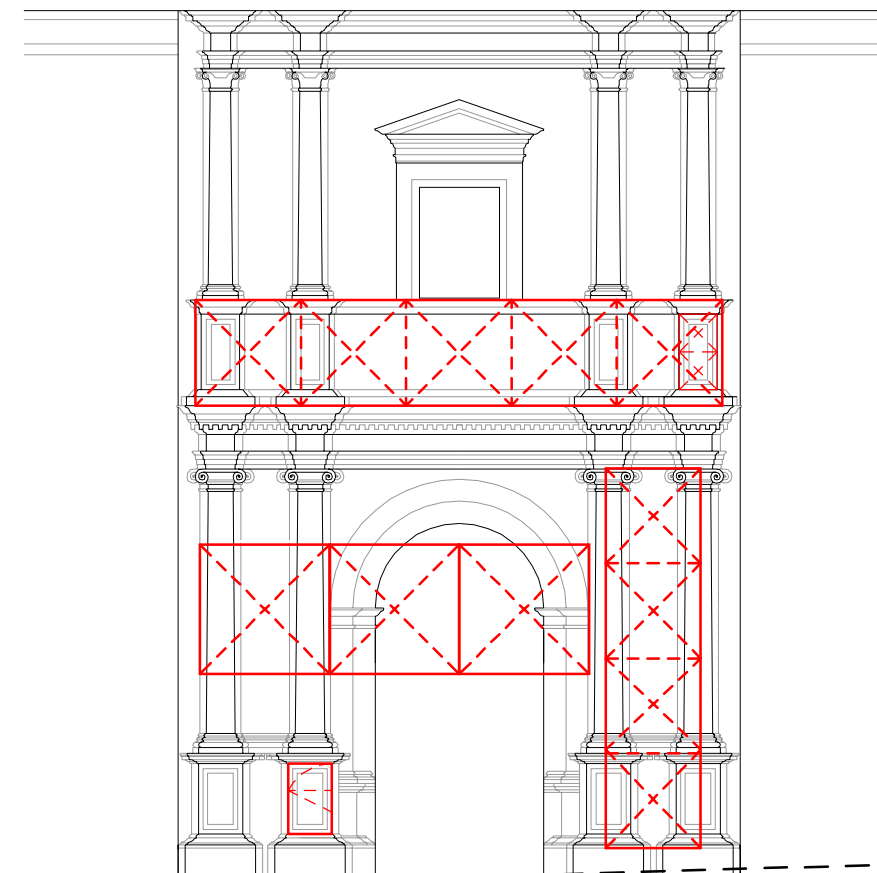

PROPORCIÓN 1:1

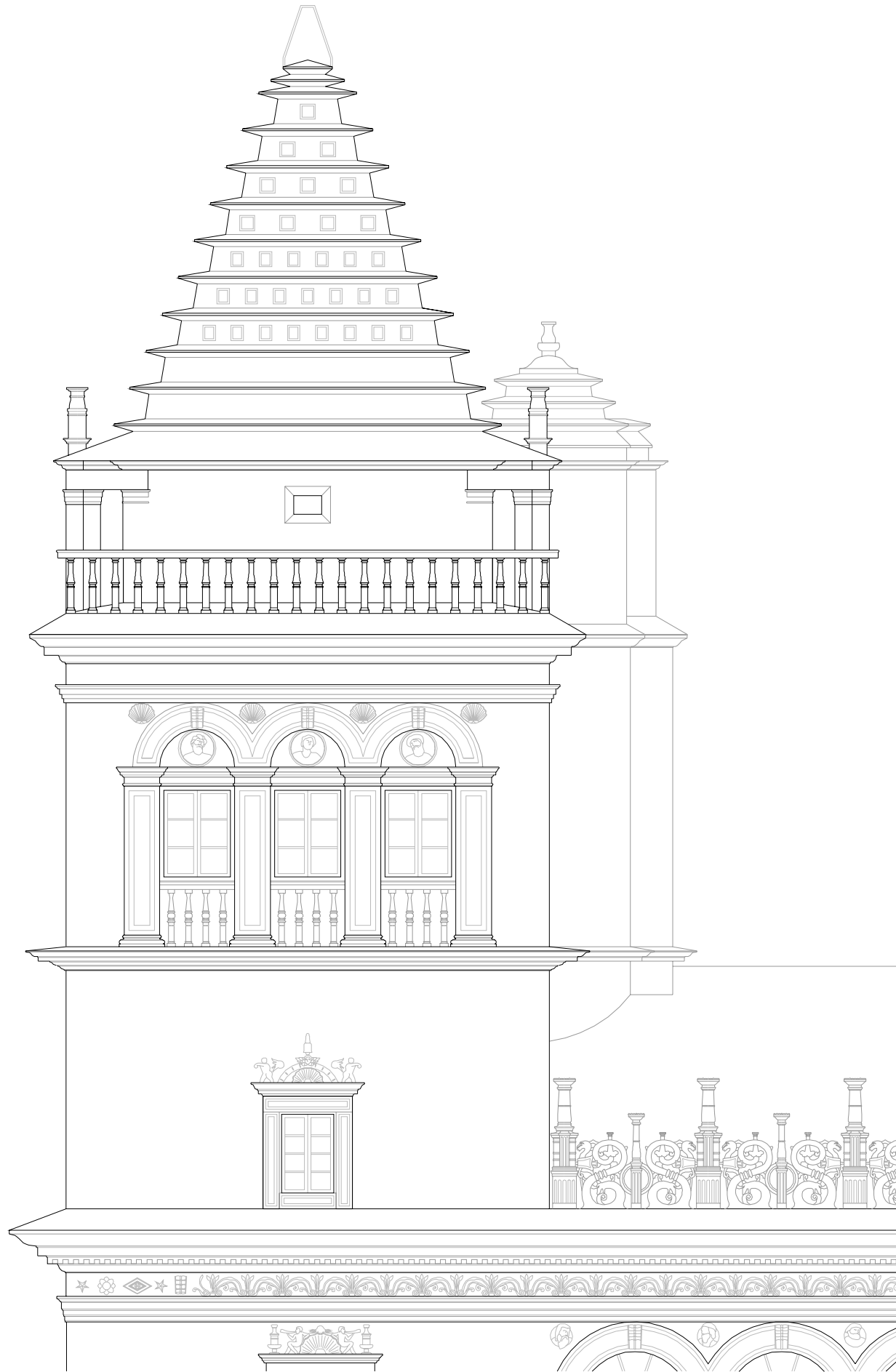

DETALLE TORRE e:1/75

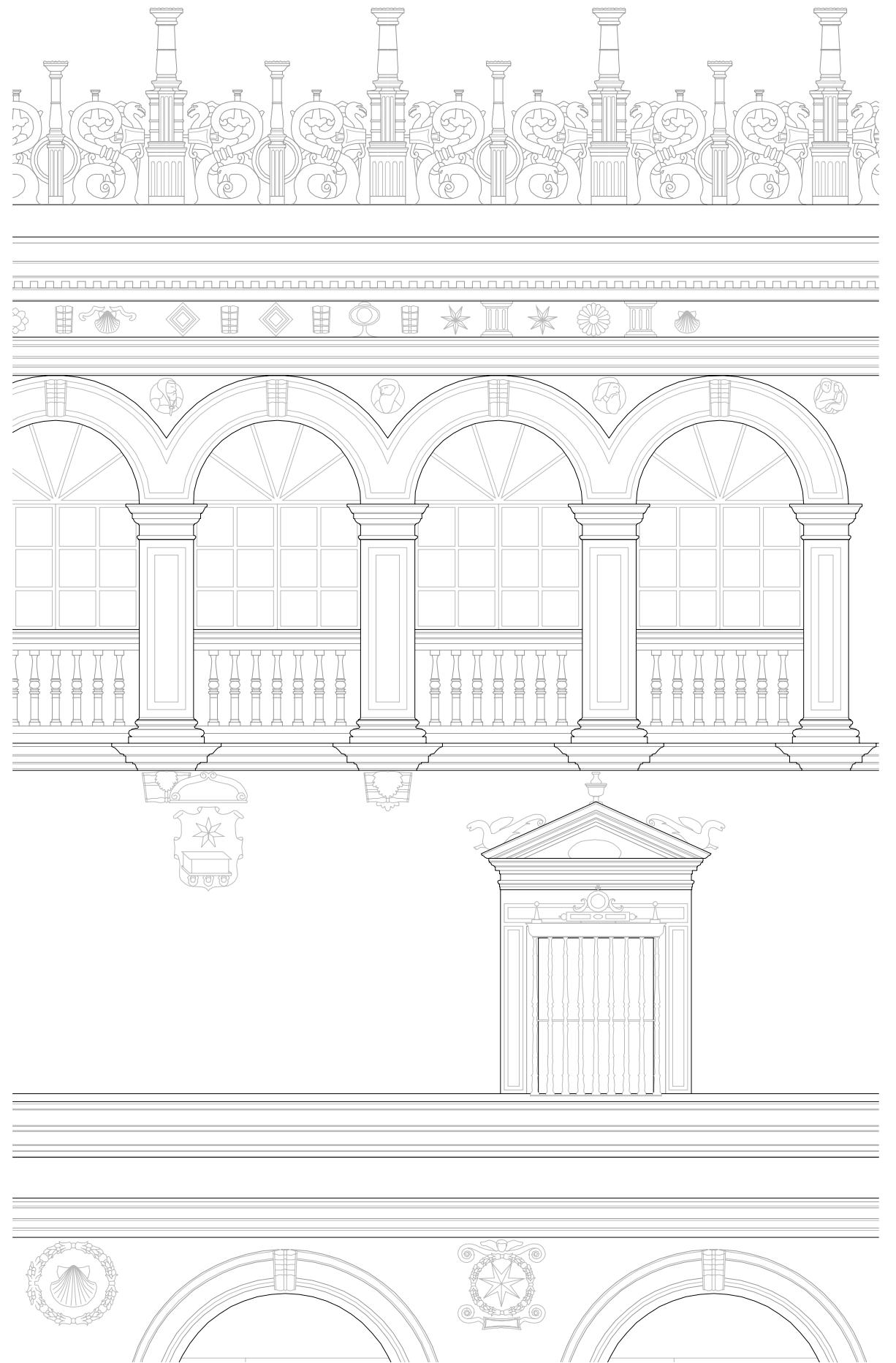

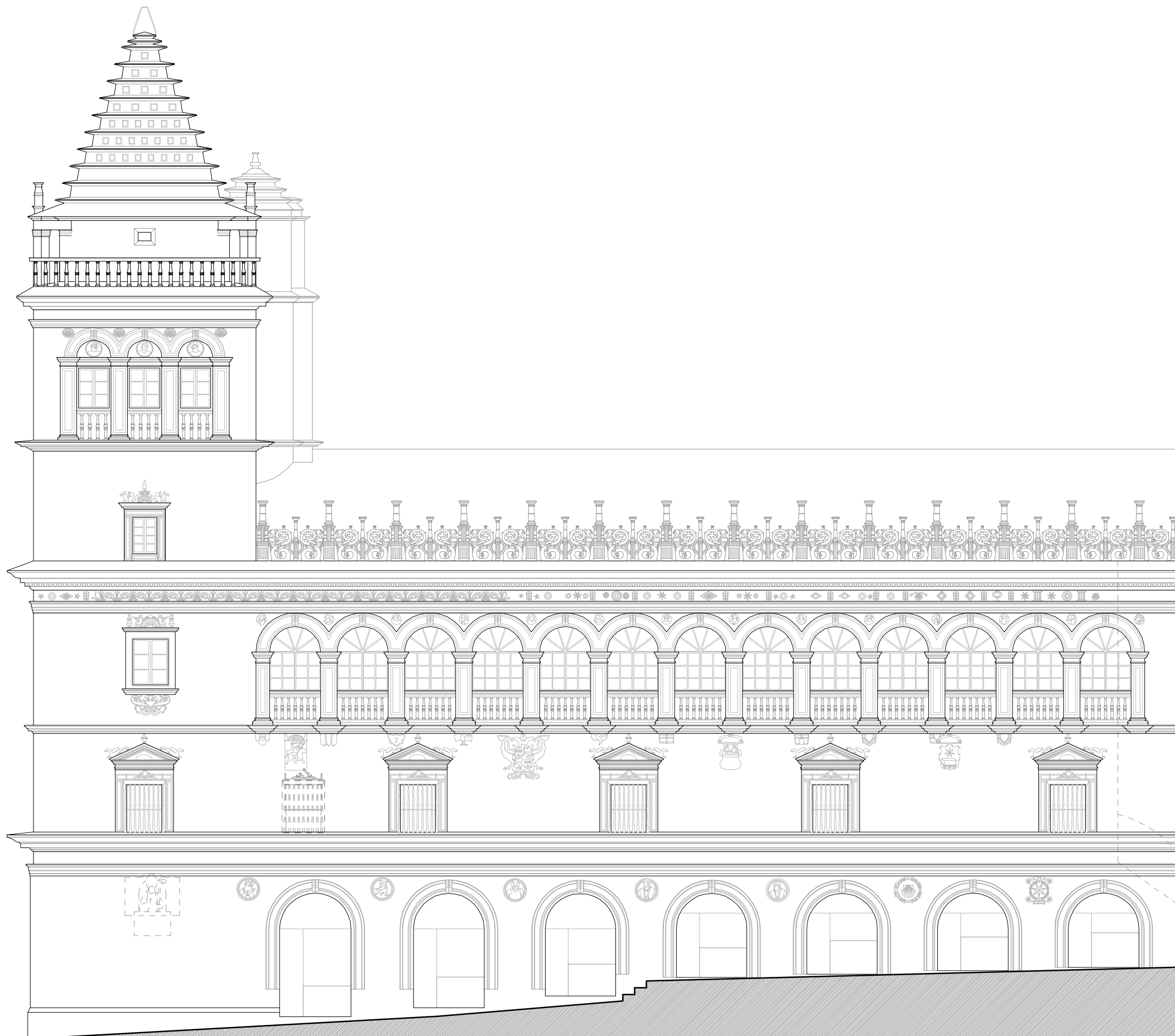

OBRA POSTERIOR

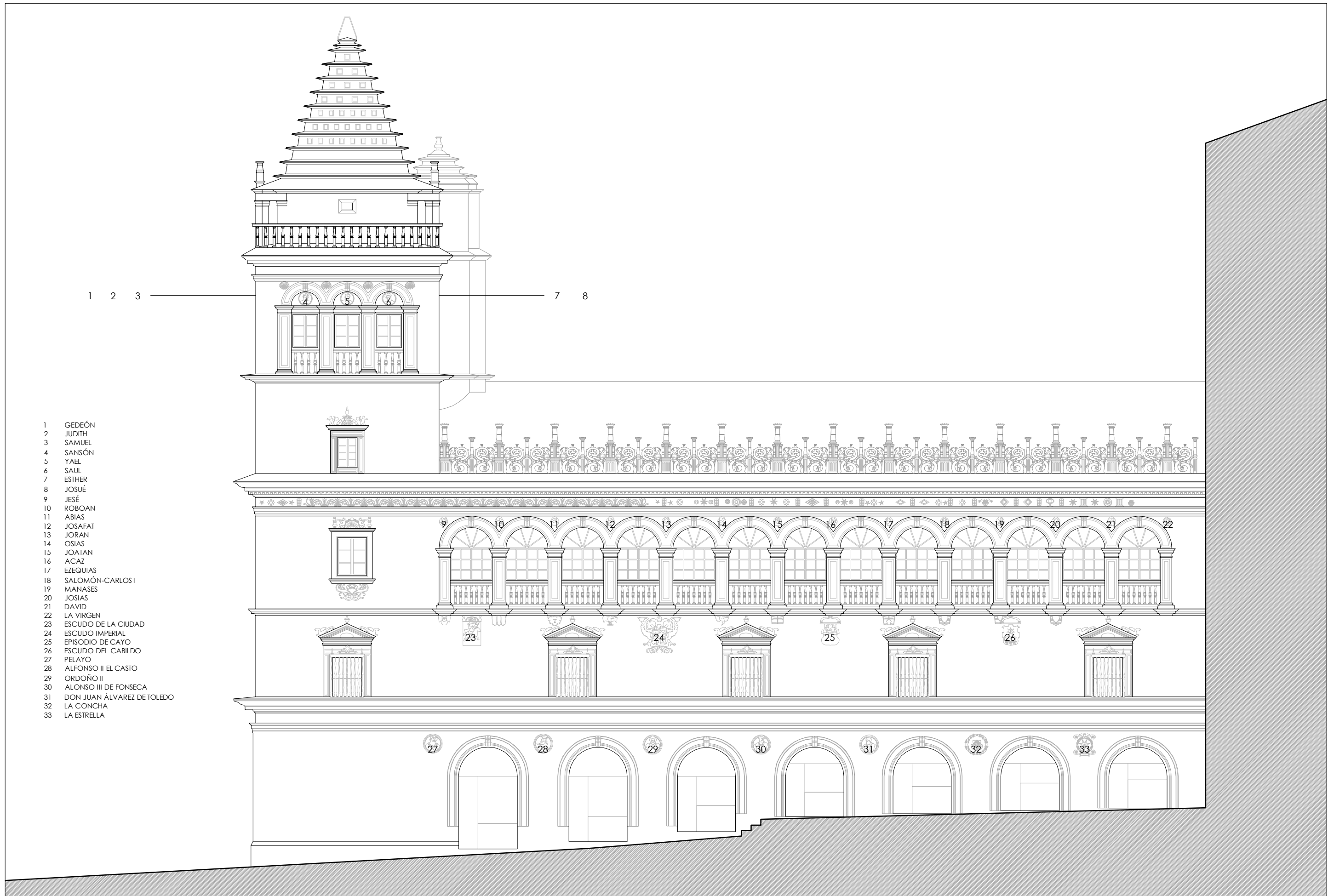

- 1 GEDEÓN
- 2 JUDITH
- 3 SAMUEL
- 4 SANSÓN
- 5 YAEL
- 6 SAUL
- 7 ESTHER
- 8 JOSUÉ
- 9 JESÉ
- 10 ROBOAN
- 11 ABIAS
- 12 JOSAFAT
- 13 JORAN
- 14 OSIAS
- 15 JOATAN
- 16 ACAZ
- 17 EZEQUIAS
- 18 SALOMÓN-CARLOS I
- 19 MANASES
- 20 JOSIAS
- 21 DAVID
- 22 LA VIRGEN
- 23 ESCUDO DE LA CIUDAD
- 24 ESCUDO IMPERIAL
- 25 EPISODIO DE CAYO
- 26 ESCUDO DEL CABILDO
- 27 PELAYO
- 28 ALFONSO II EL CASTO
- 29 ORDOÑO II
- 30 ALONSO III DE FONSECA
- 31 DON JUAN ÁLVAREZ DE TOLEDO
- 32 LA CONCHA
- 33 LA ESTRELLA

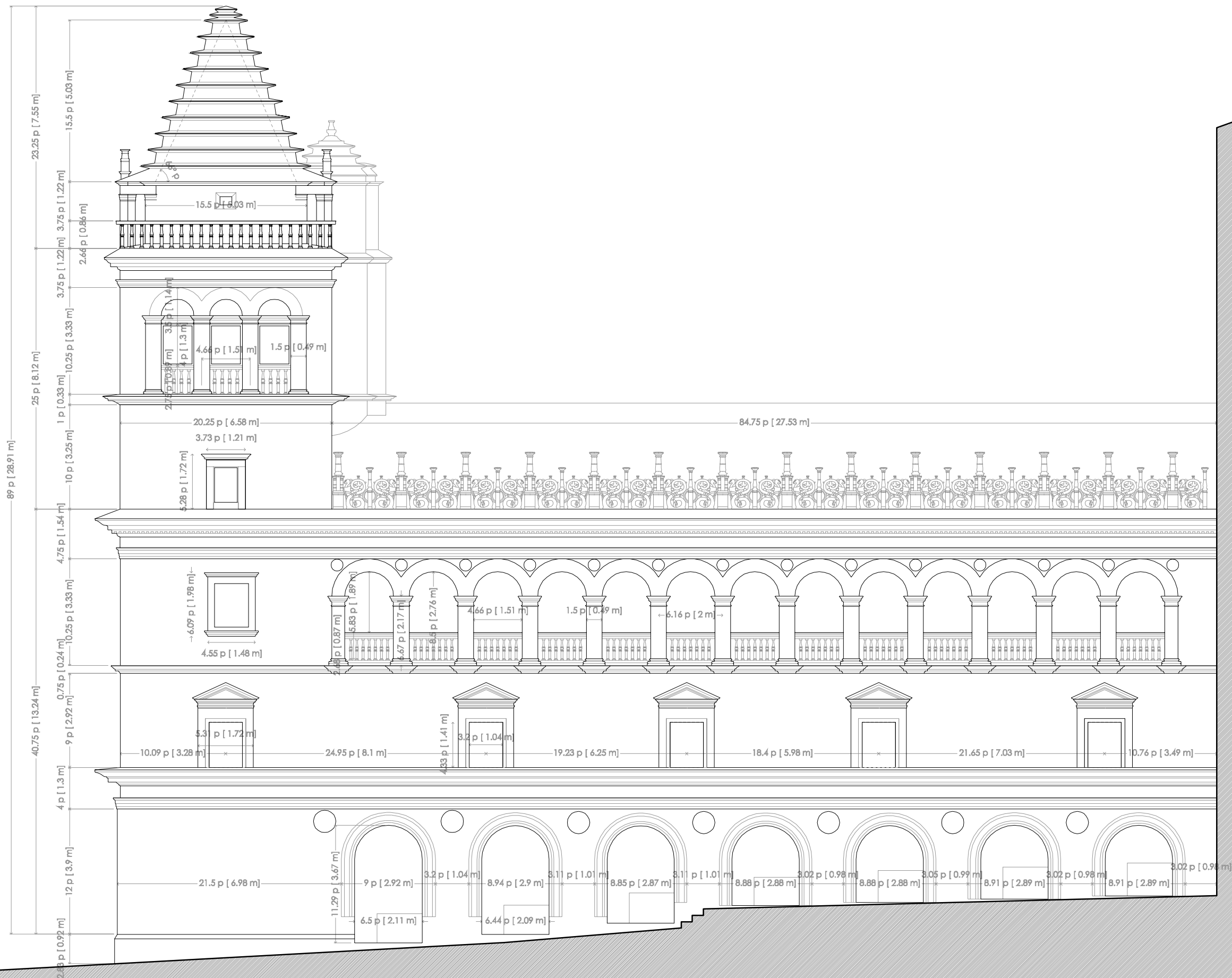

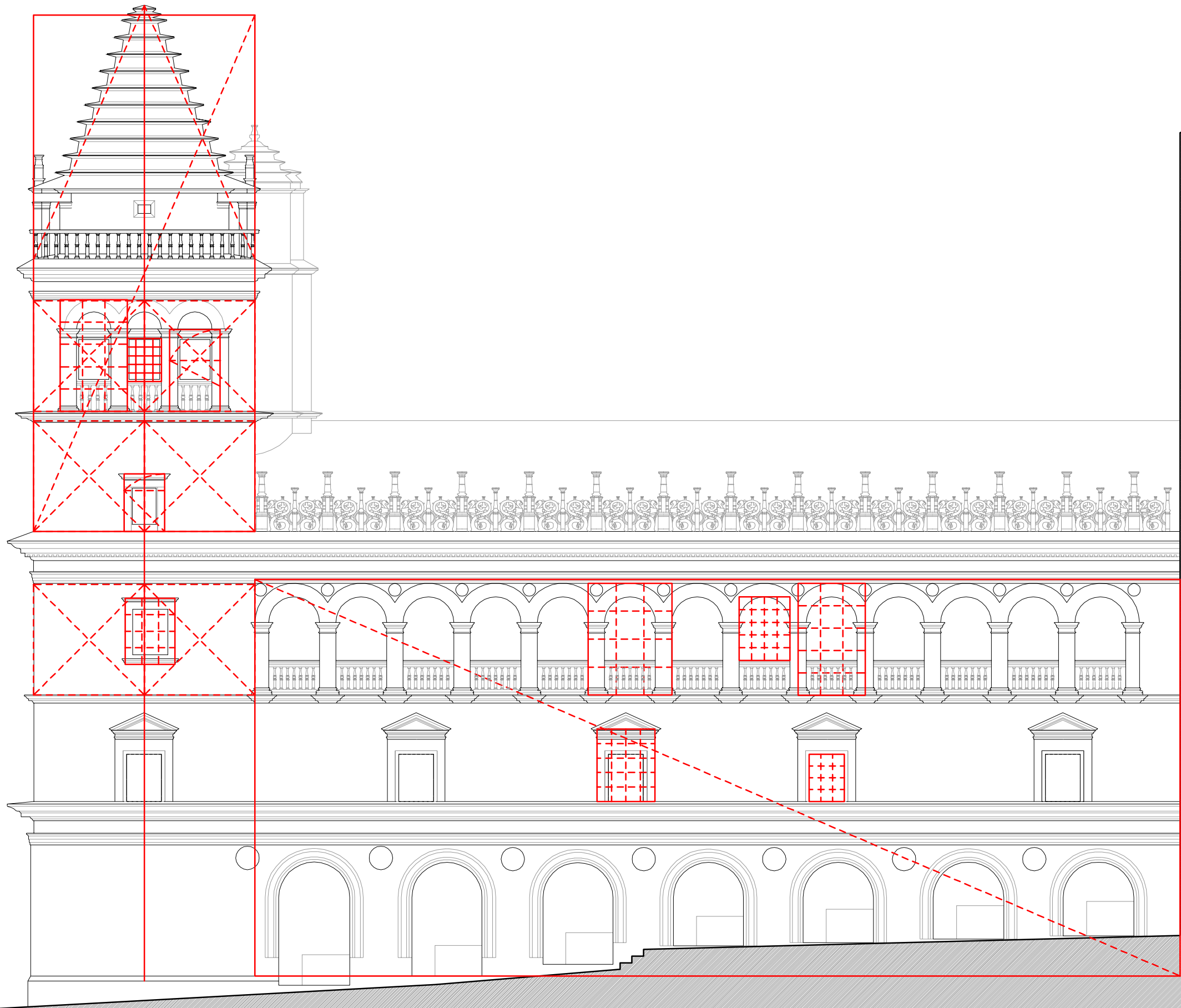

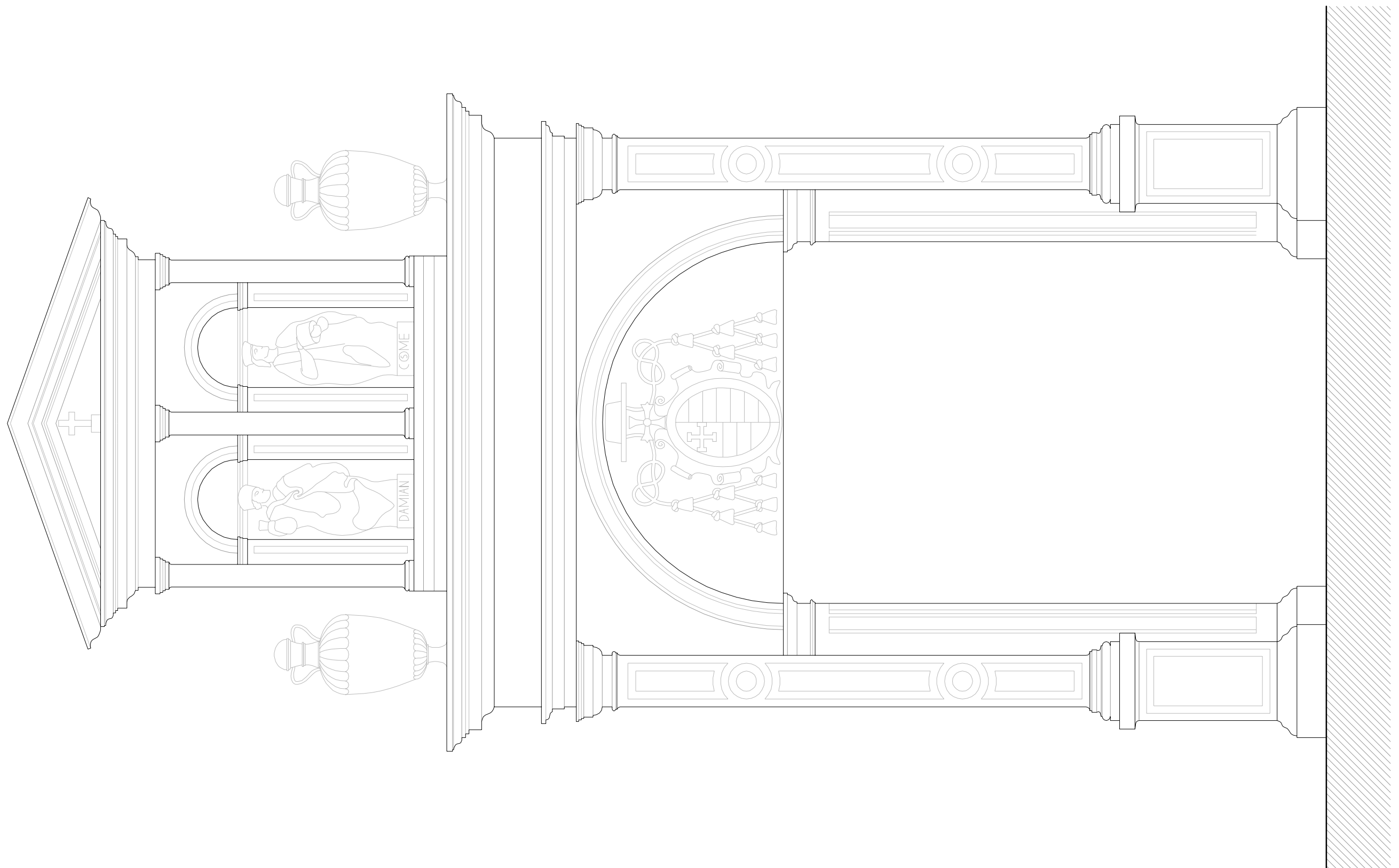

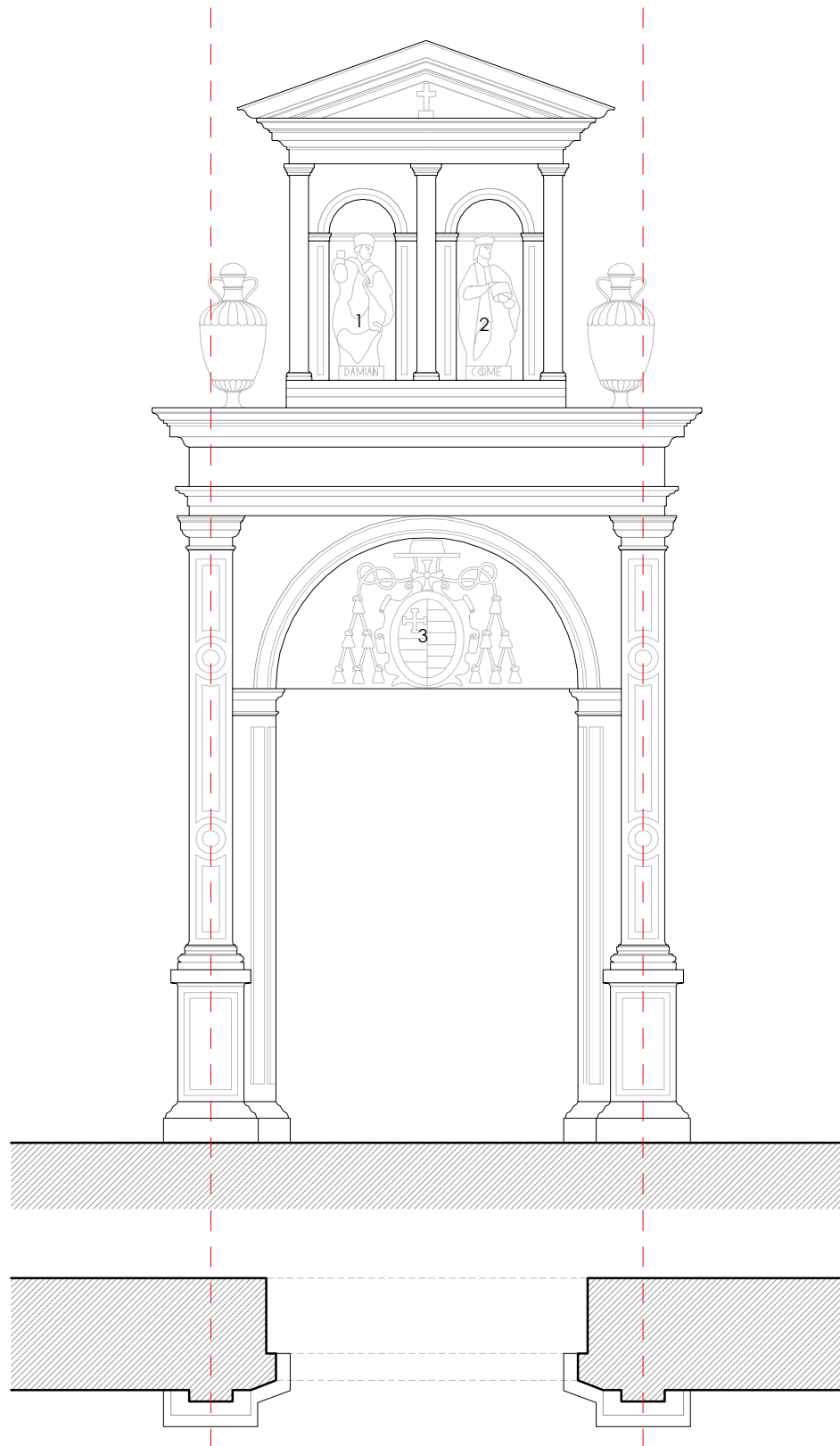

- 1 SAN DAMIÁN
- 2 SAN COSME
- 3 ESCUDO DEL ARZOBISPO SANCLEMENTE

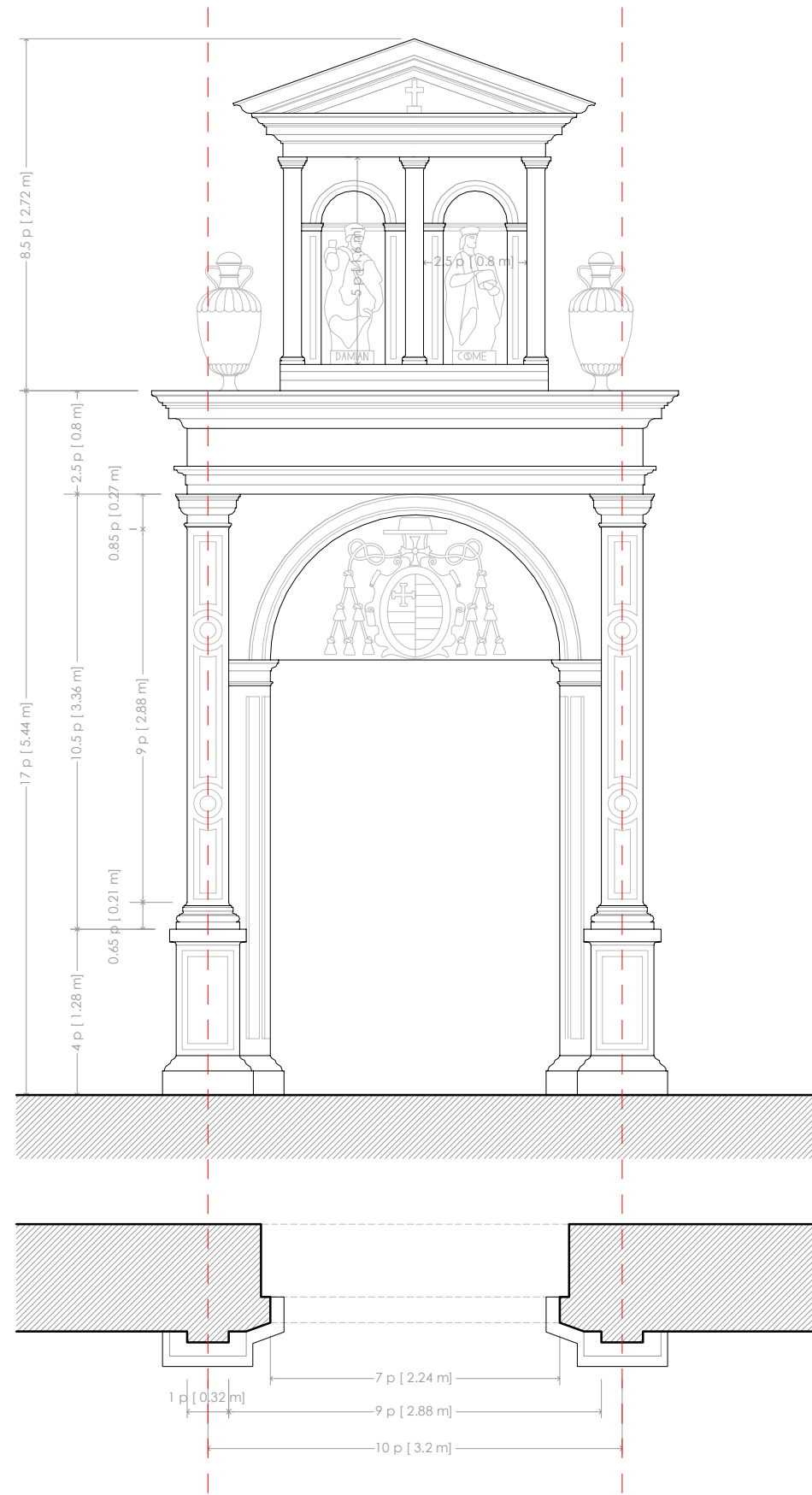

- 4 p [1.28 m]
- 0.65 p [0.21 m]
- 9 p [2.88 m]
- 10.5 p [3.36 m]
- 0.85 p [0.27 m]
- 2.5 p [0.8 m]
- 8.5 p [2.72 m]
- 1 p [0.32 m]
- 7 p [2.24 m]
- 9 p [2.88 m]
- 10 p [3.2 m]

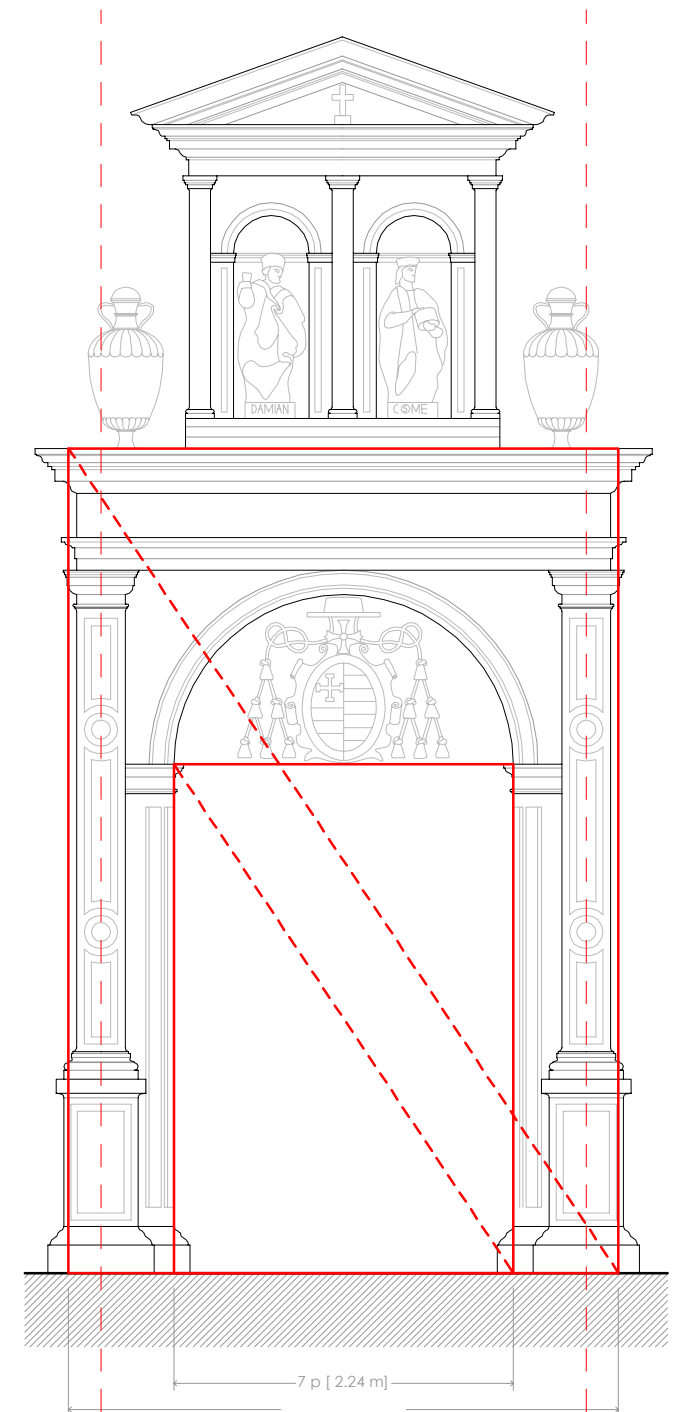
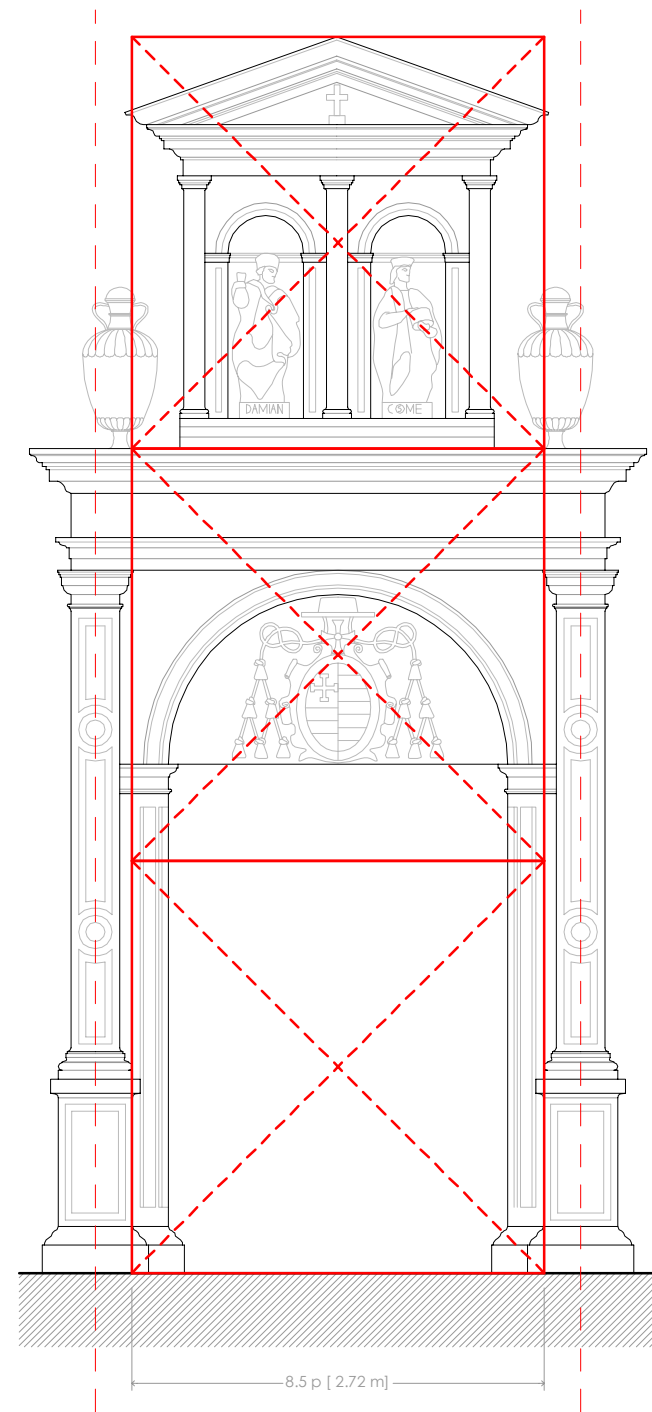
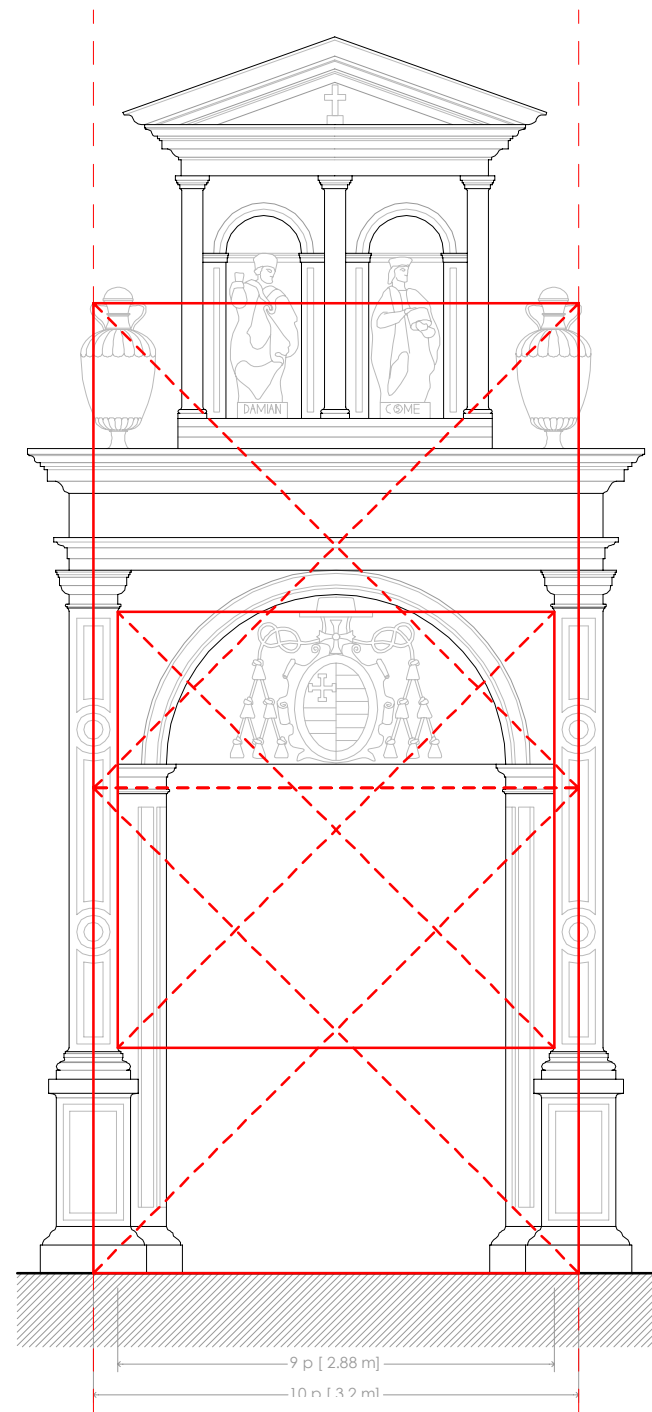
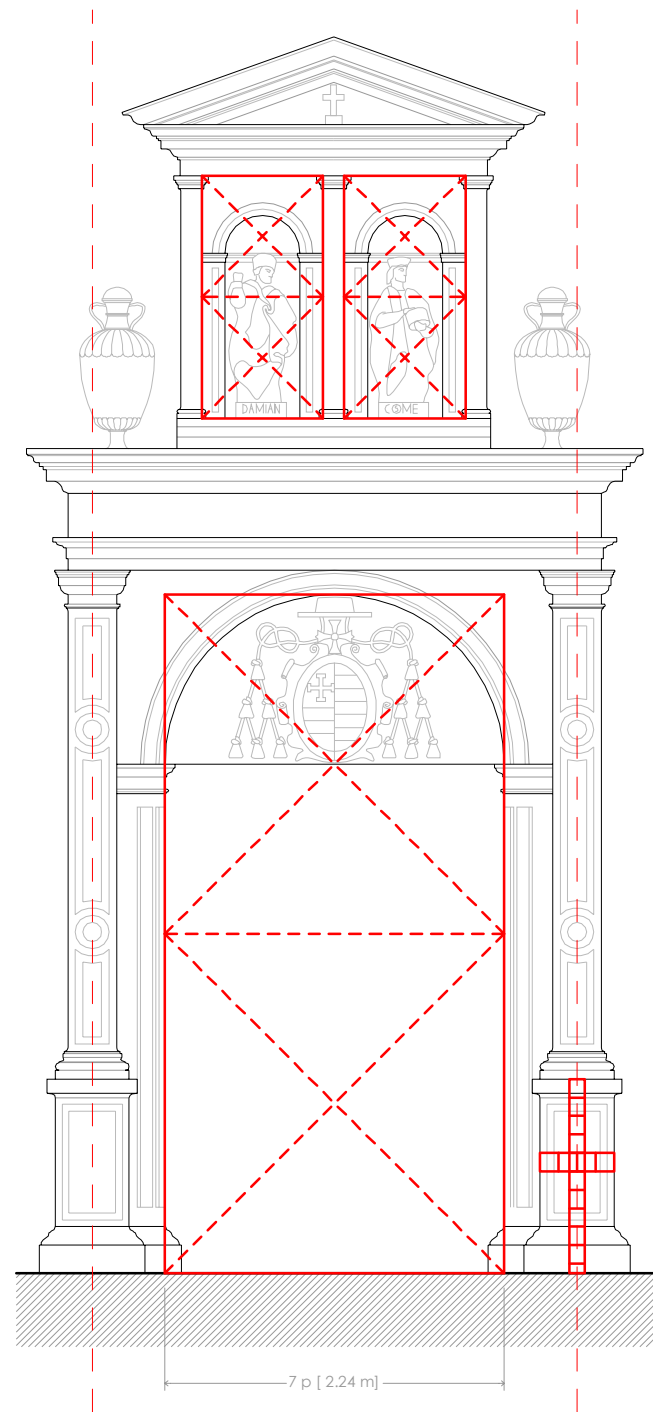

PROPORCIÓN 3:2

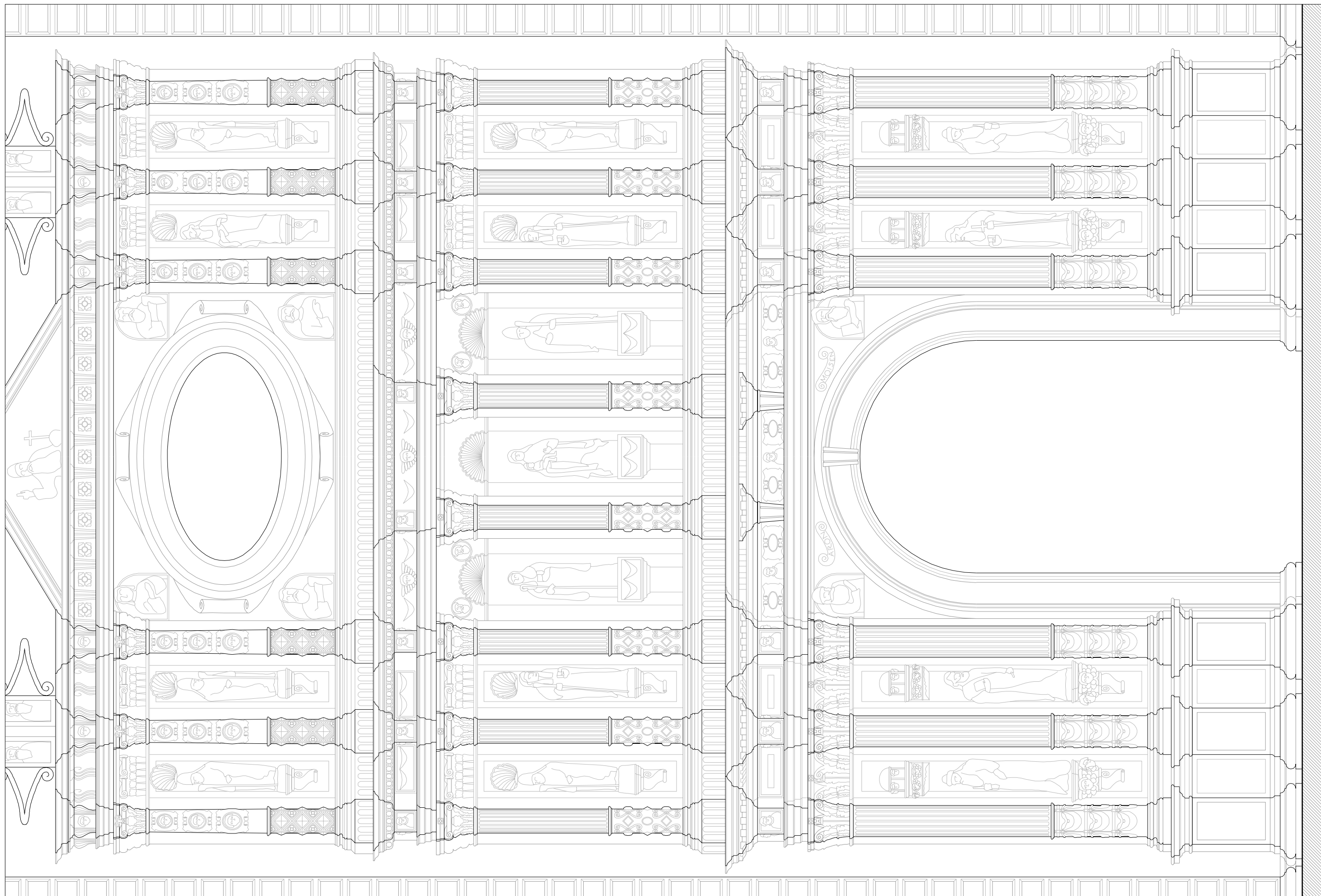

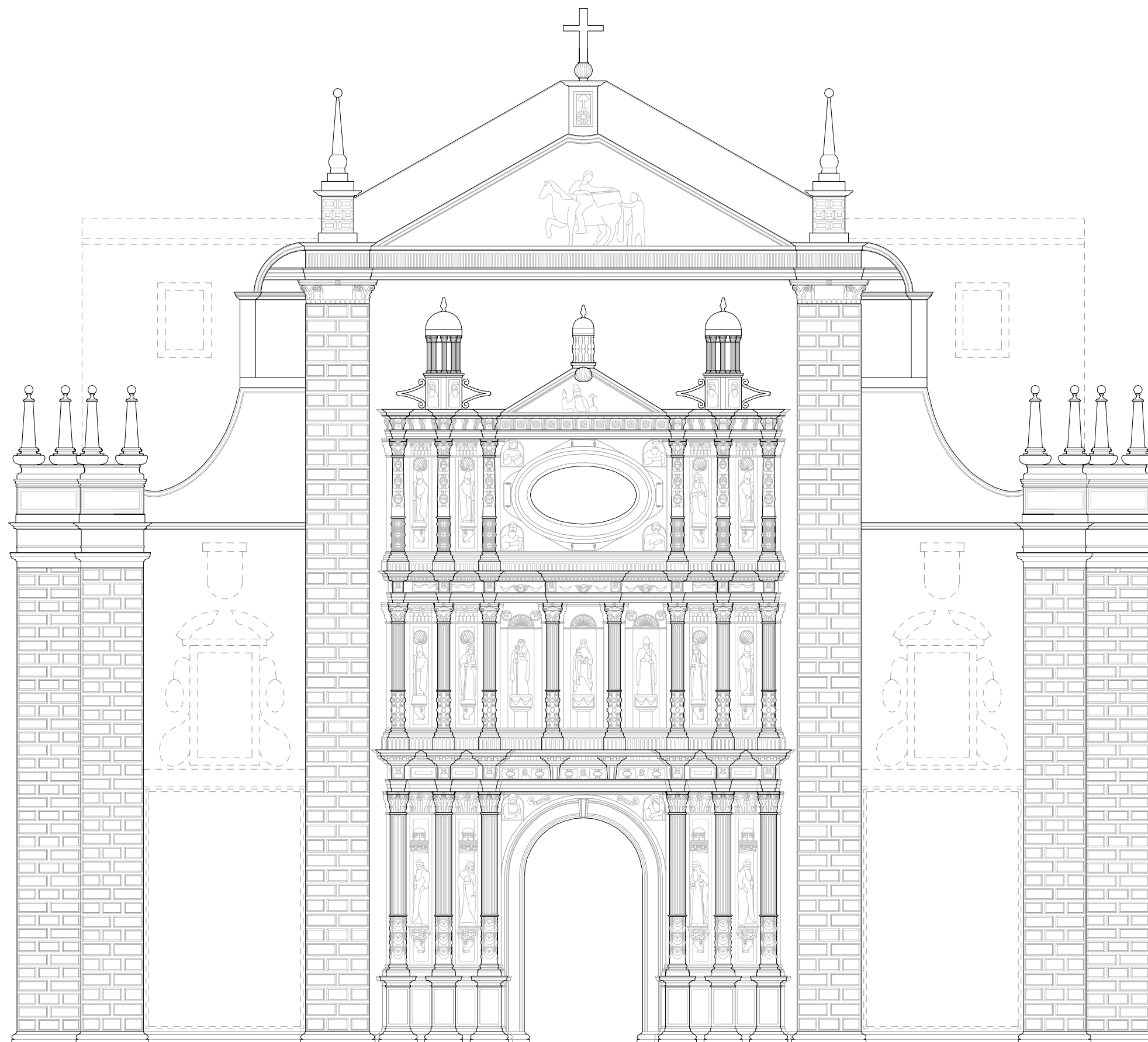

OBRA POSTERIOR

FACHADAS

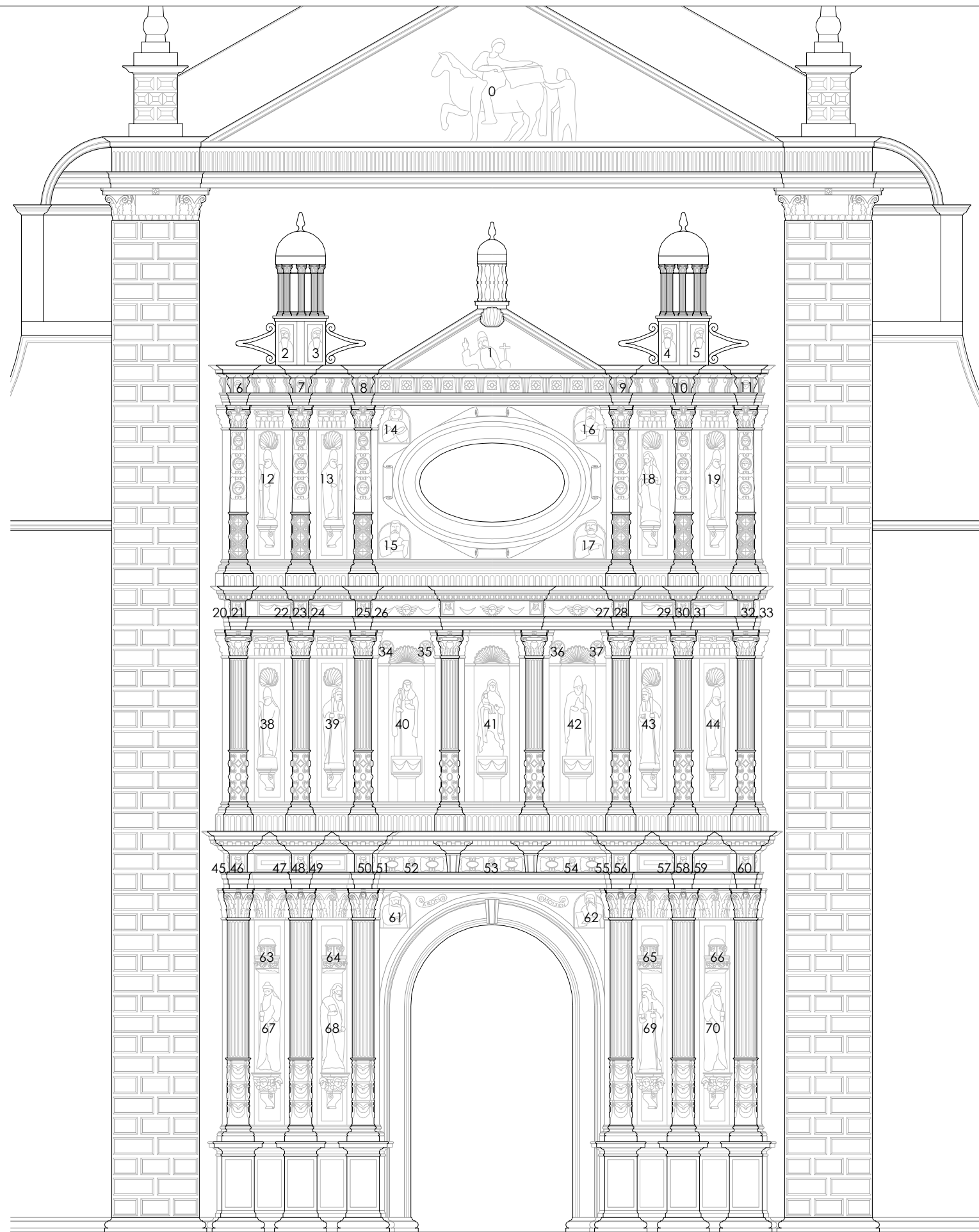

0 SAN MARTÍN ECUESTRE

- 1 DIOS PADRE
- 2 REY DAVID
- 3 PROFETA DANIEL
- 4 PROFETA EZEQUIEL
- 5 SALOMÓN
- 6 PERSONAJE FEMENINO
- 7 PERSONAJE FEMENINO
- 8 PERSONAJE FEMENINO
- 9 PERSONAJE FEMENINO
- 10 PERSONAJE FEMENINO
- 11 PERSONAJE FEMENINO
- 12 SAN AMBROSIO
- 13 SAN GREGORIO MAGNO
- 14 SAN JUAN
- 15 SAN MARCOS
- 16 SAN MATEO
- 17 SAN LUCAS
- 18 SAN JERÓNIMO
- 19 SAN AGUSTÍN
- 20 DOÑA ELVIRA
- 21 ORDOÑO II
- 22 ABAD GUTO
- 23 ALFONSO II EL CASTO
- 24 ISABEL LA CATÓLICA
- 25 FERNÁNDO EL CATÓLICO
- 26 PERSONAJE BARBADO
- 27 GUERRERO
- 28 DAMA
- 29 HOMBRE CON TOGA
- 30 MUJER CON VELO
- 31 REY ANCIANO
- 32 REY
- 33 GUERRERO CON CORAZA
- 34 ISAÍAS
- 35 EZEQUIEL

- 36 HABACUC
- 37 MIQUEAS
- 38 SAN ROSENDO
- 39 SAN BERNARDO
- 40 SAN BENITO
- 41 LA VIRGEN
- 42 SAN ANSELMO
- 43 SAN ROBERTO
- 44 SAN PEDRO DE MEZONZO
- 45 CARLOS I
- 46 FERNANDO REY DE AUSTRIA
- 47 HÉRCULES-JUAN DE AUSTRIA
- 48 EMPERATRIZ ISABEL
- 49 ALI BAJA
- 50 ISABEL CLARA EUGENIA
- 51 FELIPE II
- 52 LUNA
- 53 CRISTO
- 54 SOL
- 55 ANA DE AUSTRIA
- 56 SELIN II
- 57 DUQUE DE ALBA
- 58 MARGARITA DE AUSTRIA
- 59 FELIPE III
- 60 SOLIMÁN EL MAGNÍFICO
- 61 AARON
- 62 MOISÉS
- 63 DOSELETE
- 64 DOSELETE
- 65 DOSELETE
- 66 DOSELETE
- 67 ISAÍAS
- 68 SAN PEDRO
- 69 SAN PABLO
- 70 JEREMÍAS

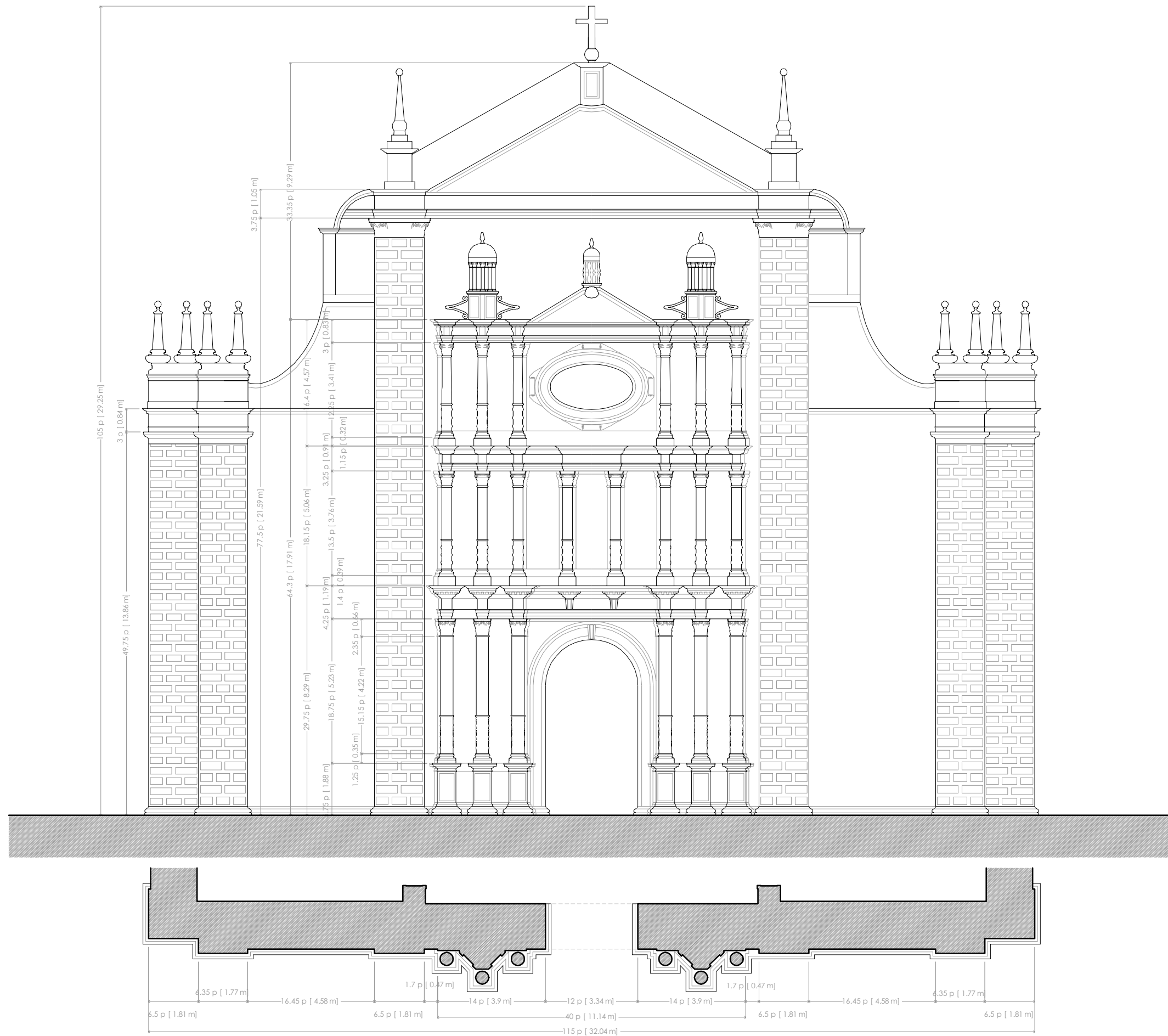

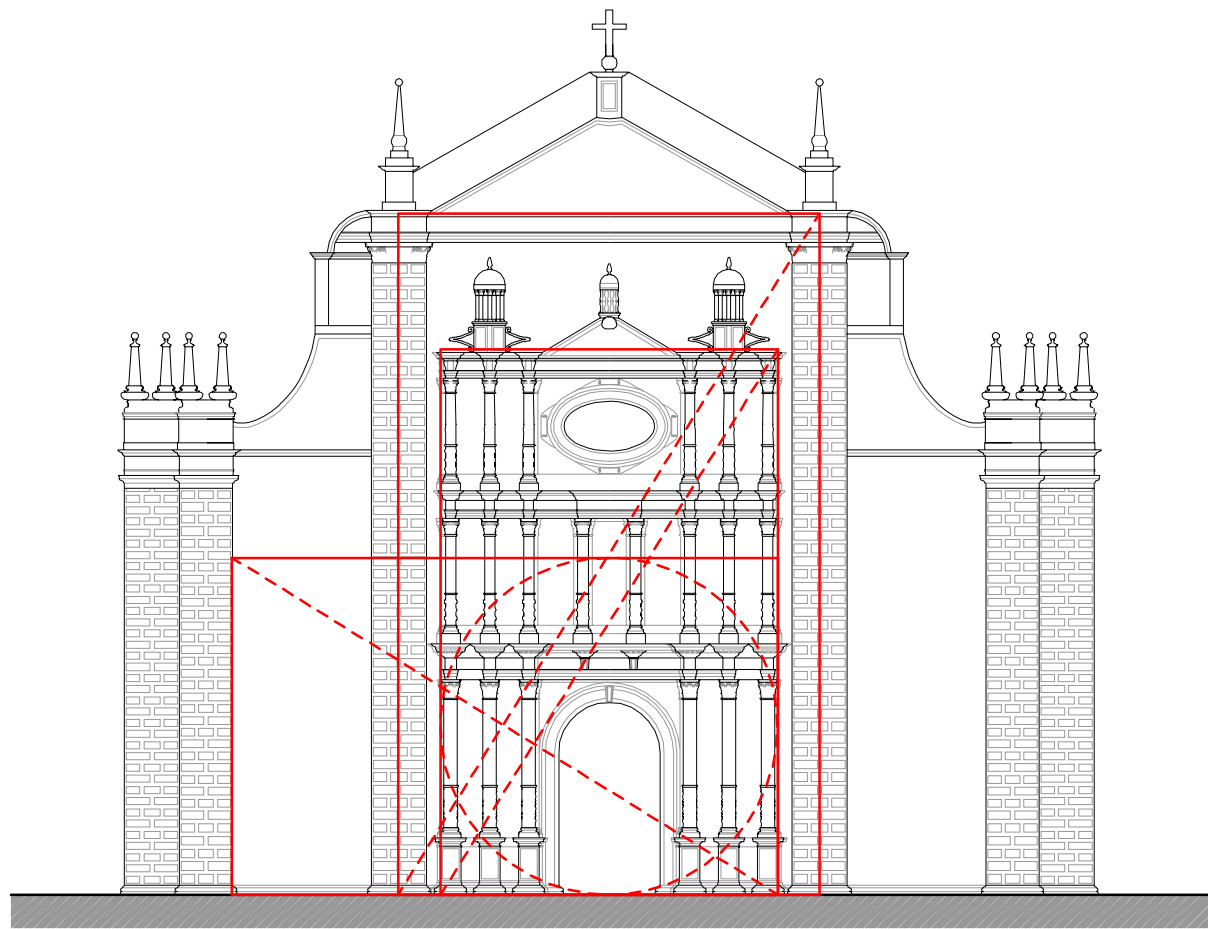

PROPORCIÓN ÁUREA

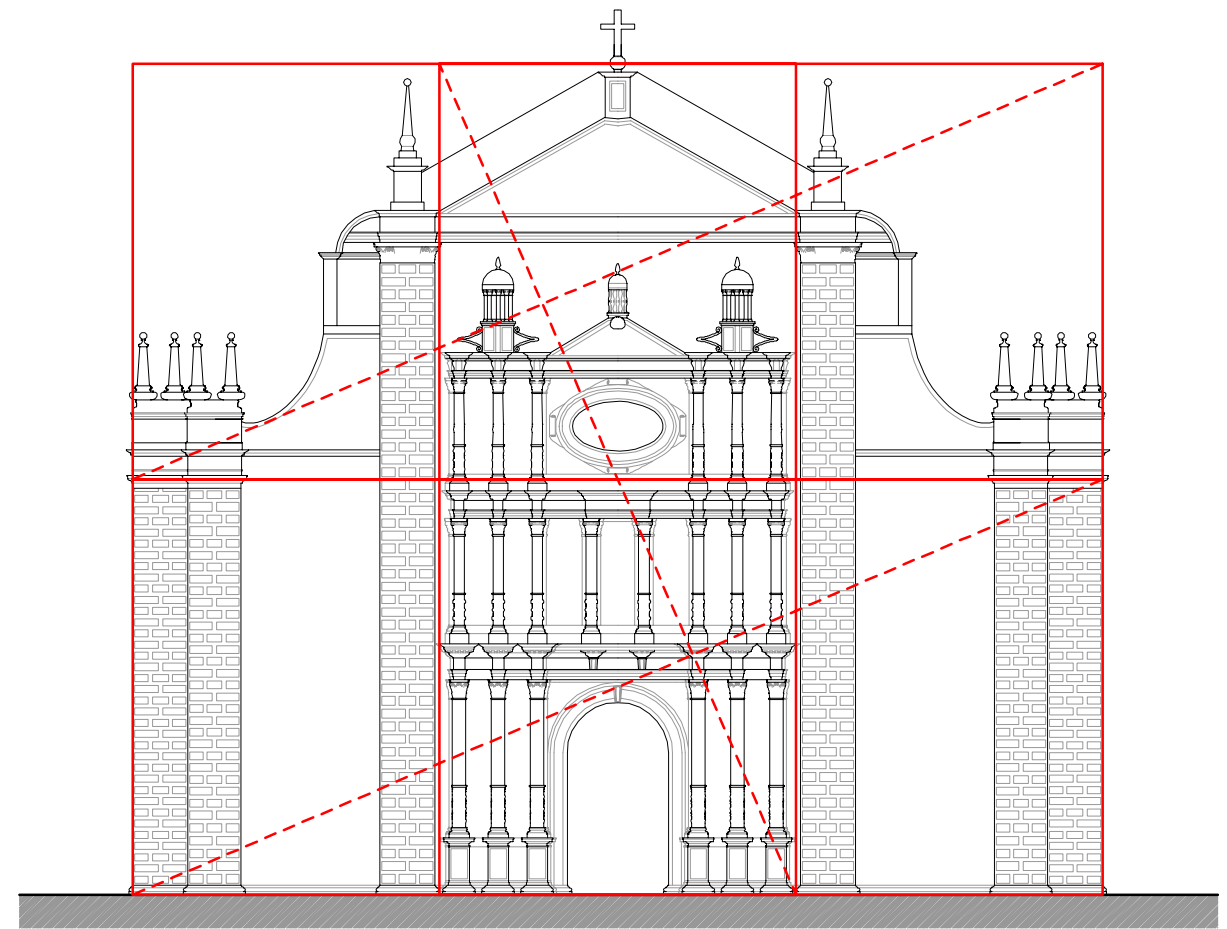

PROPORCIÓN 7:3

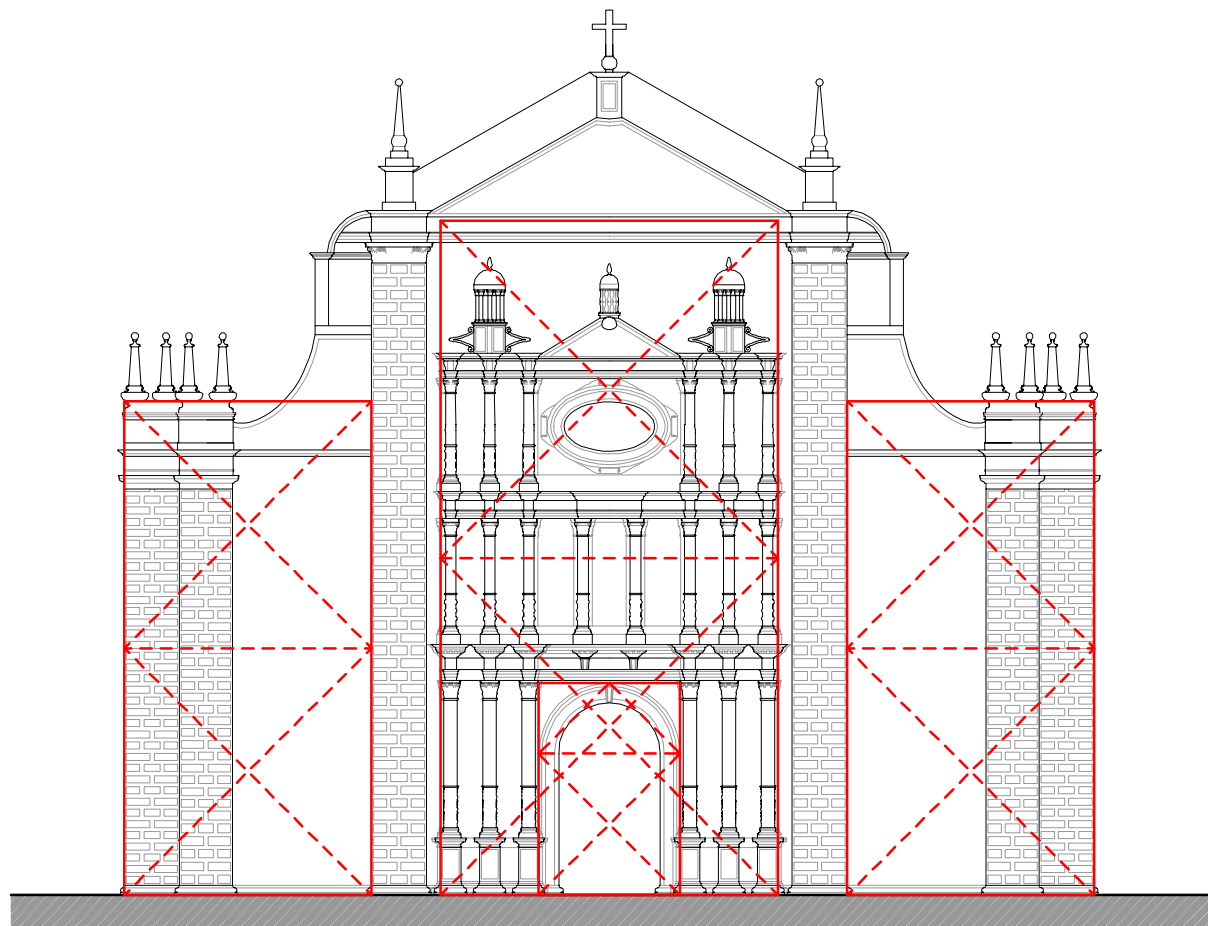

PROPORCIÓN 1:2 3:2

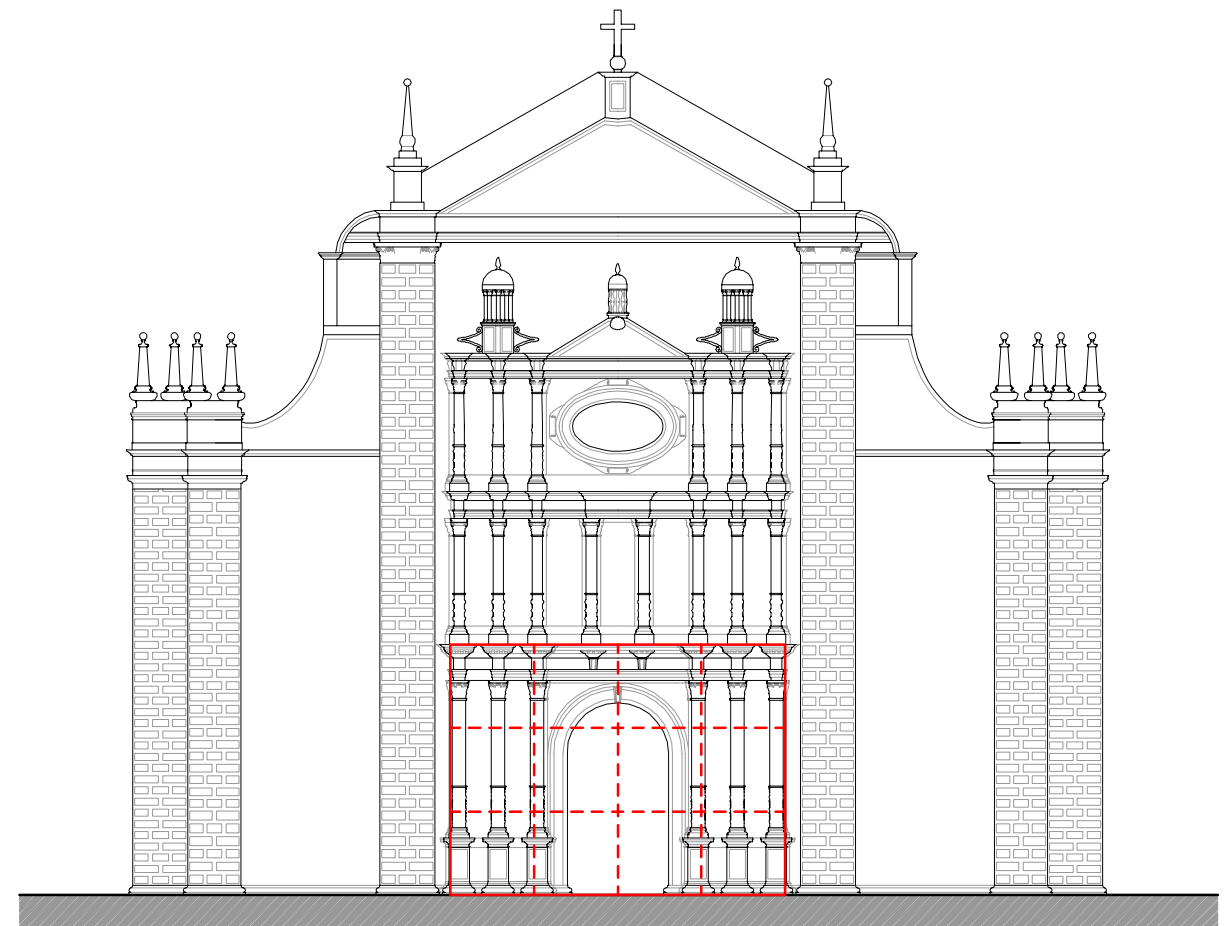

PROPORCIÓN 4:3

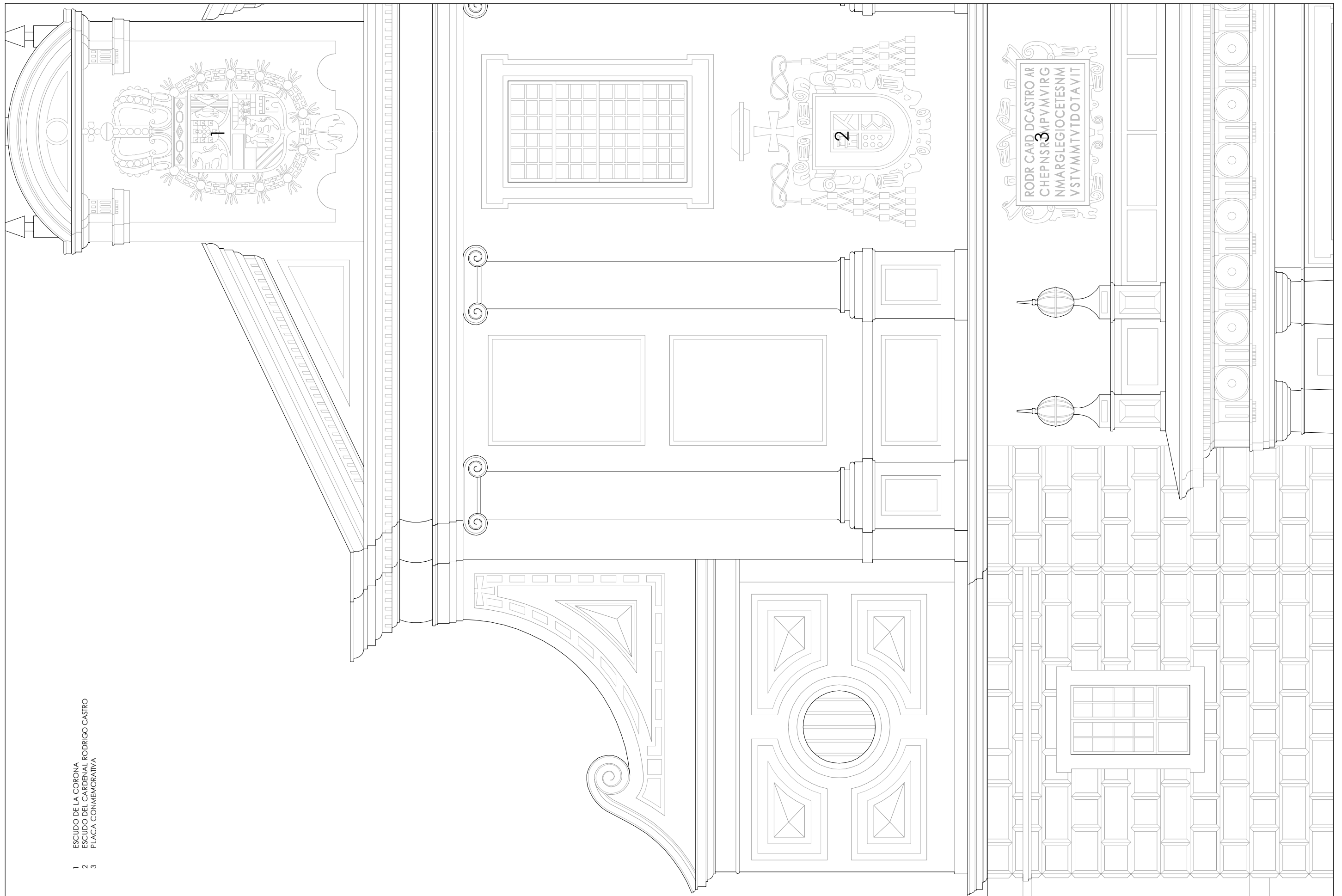

- 1 ESCUDO DE LA CORONA
- 2 ESCUDO DEL CARDENAL RODRIGO CASTRO
- 3 PLACA CONMEMORATIVA

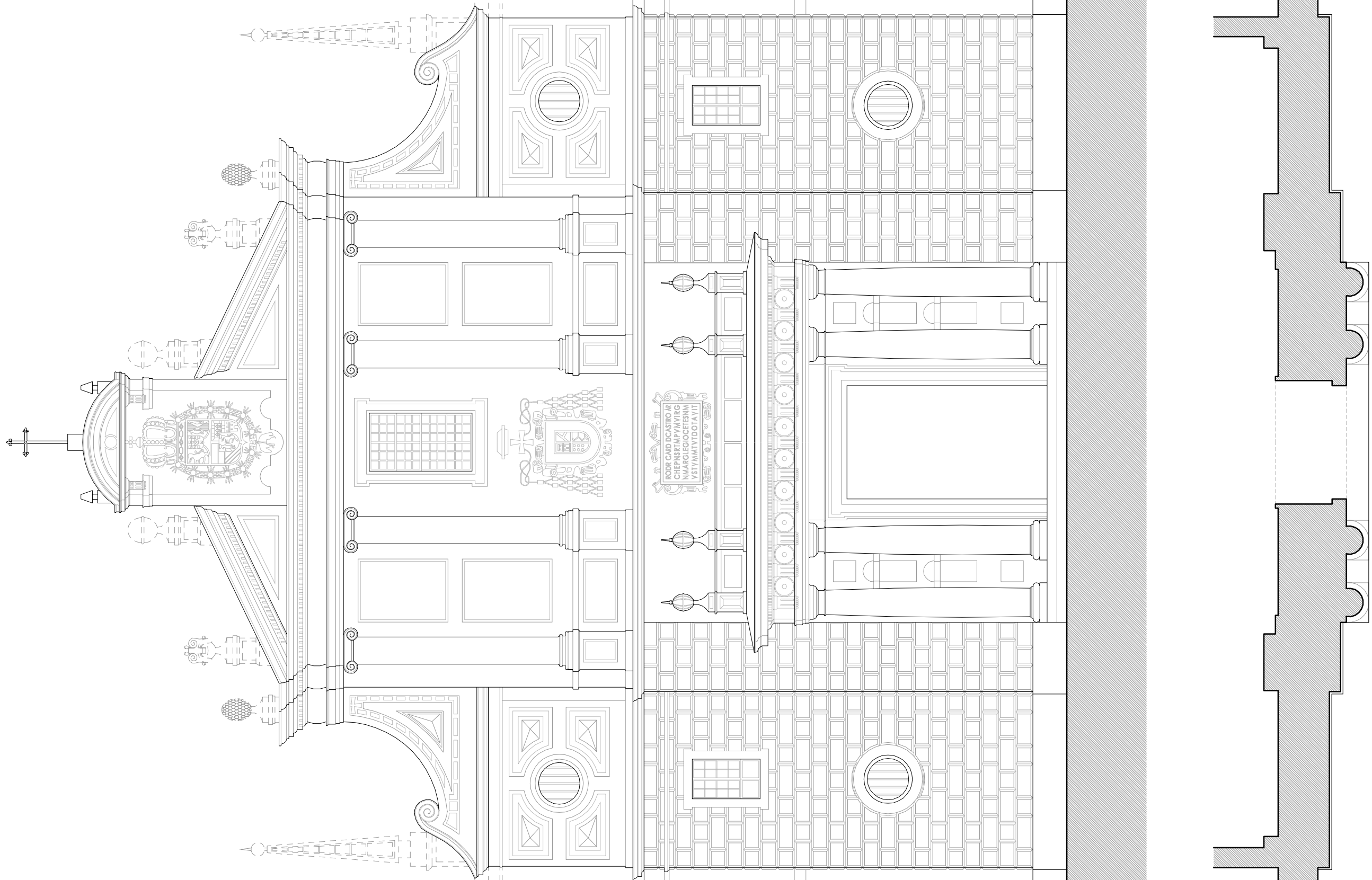

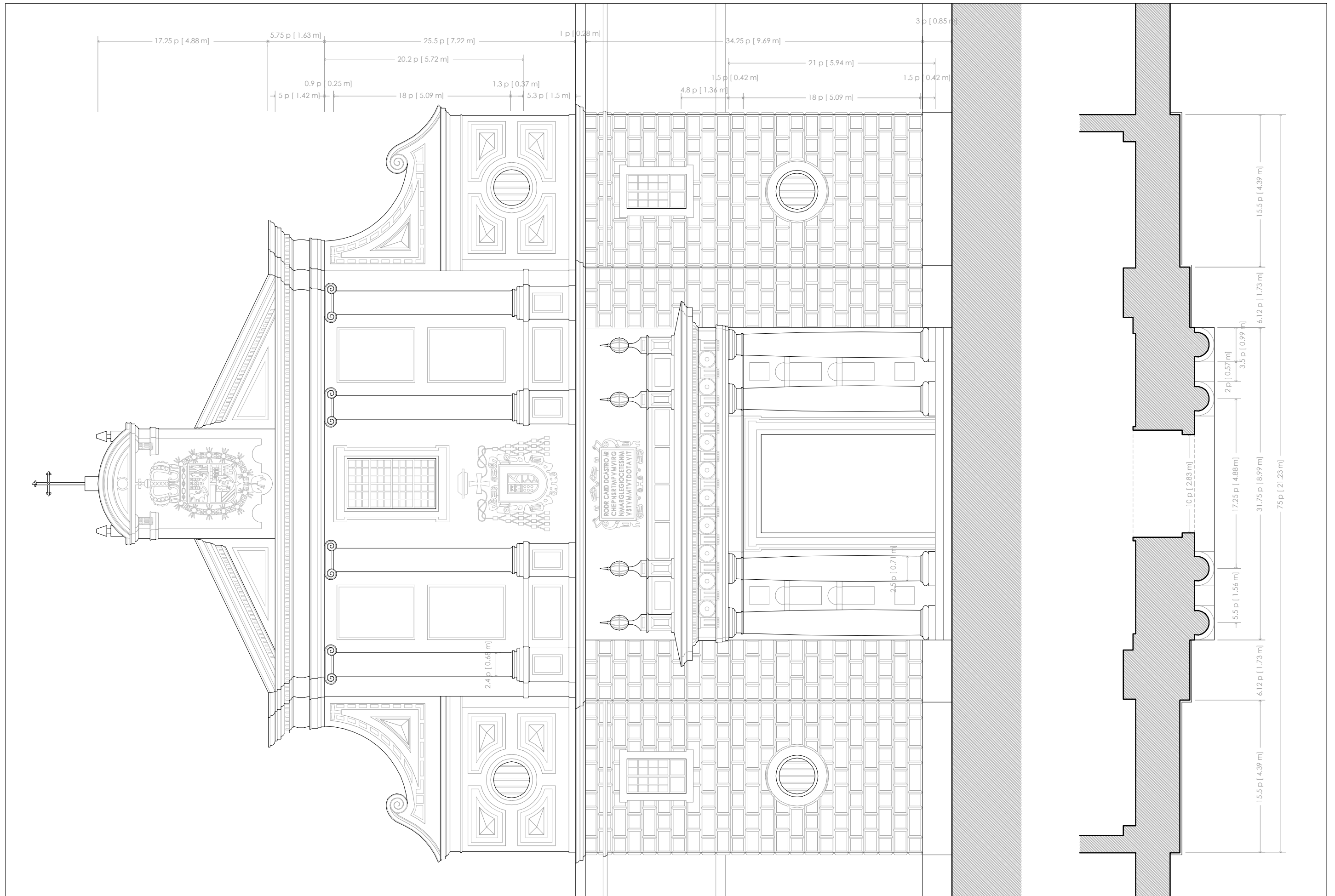

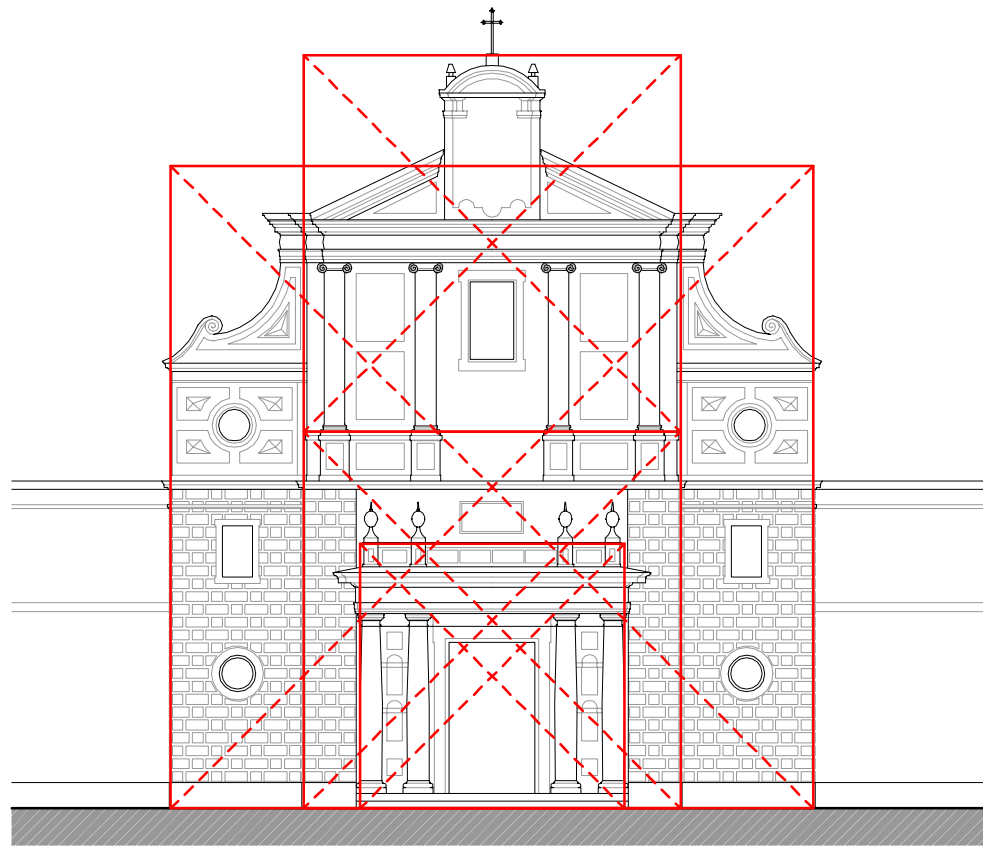

PROPORCIÓN 1:1 1:2

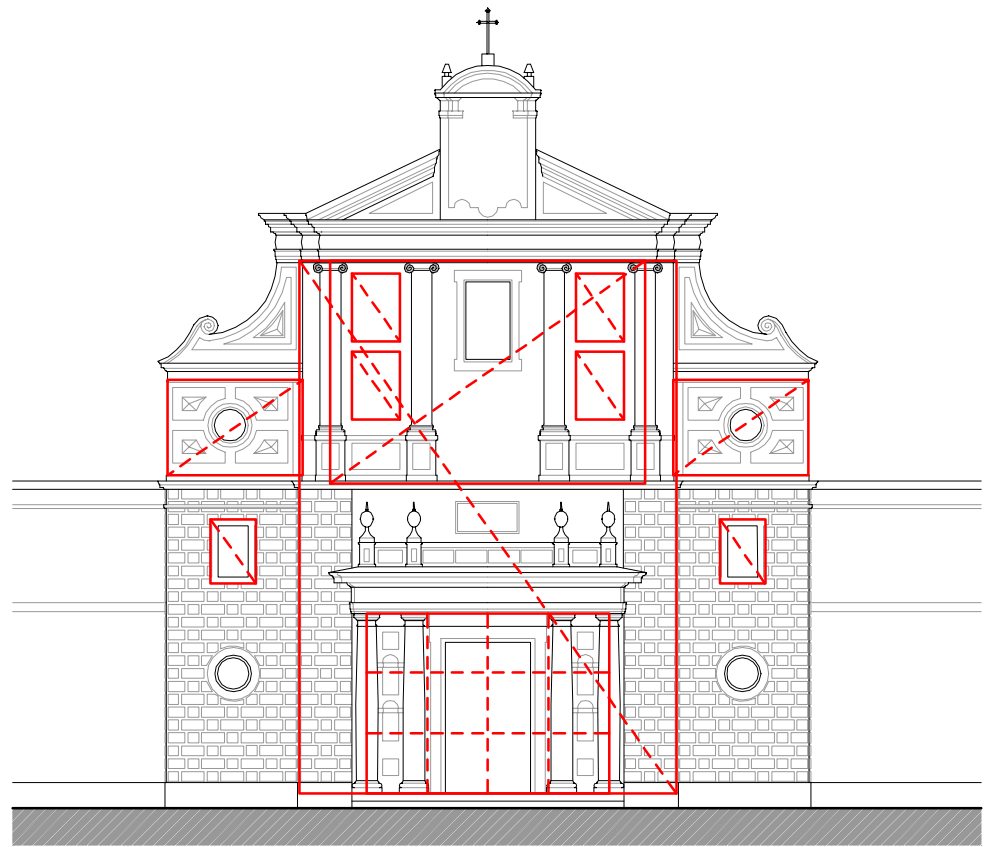

PROPORCIÓN $\sqrt{2}$ 4:3

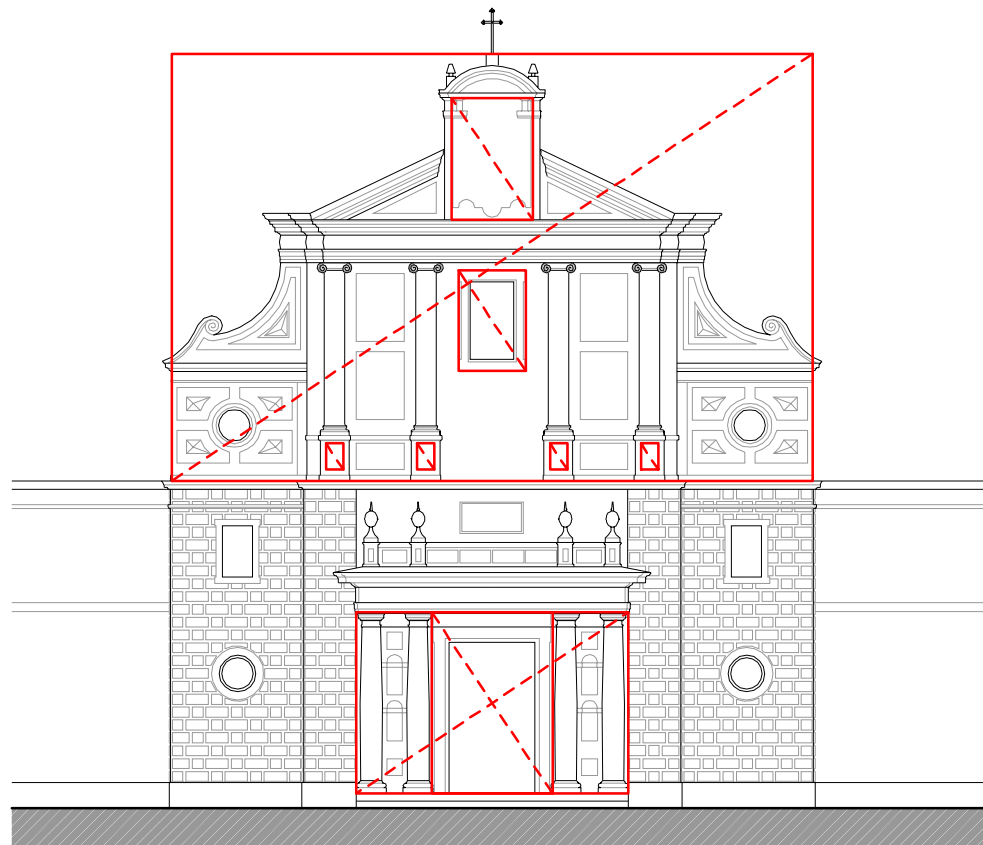

PROPORCIÓN 3:2

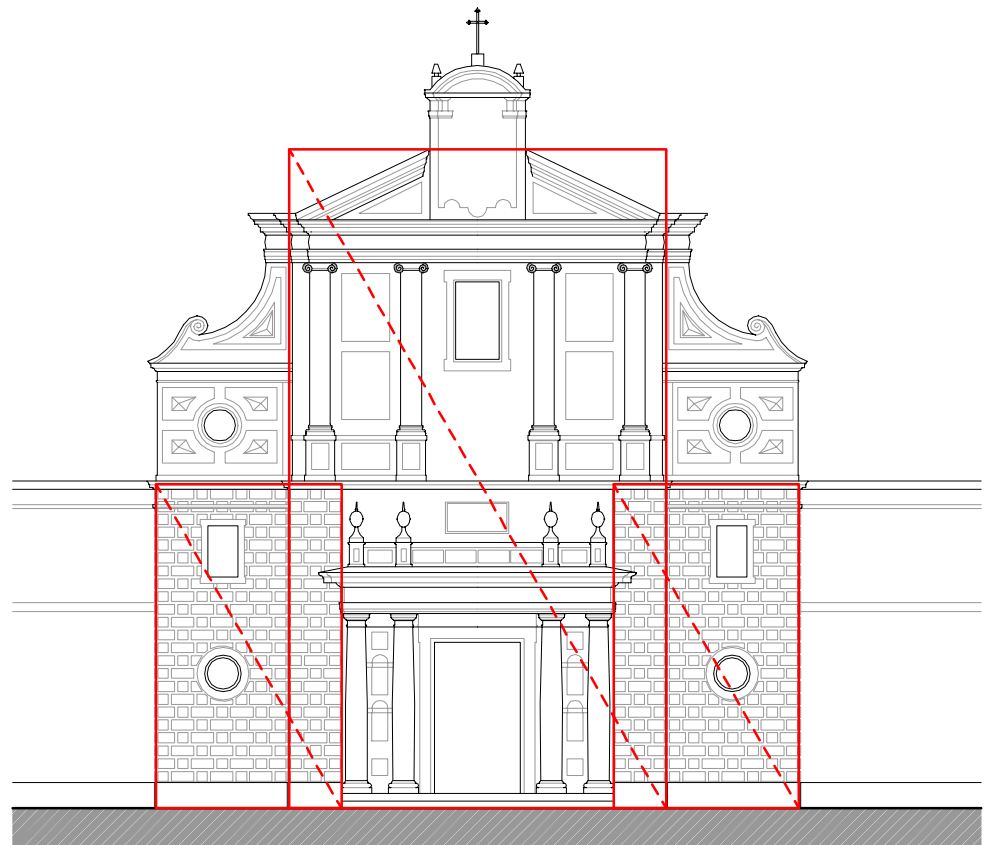

PROPORCIÓN 4:7

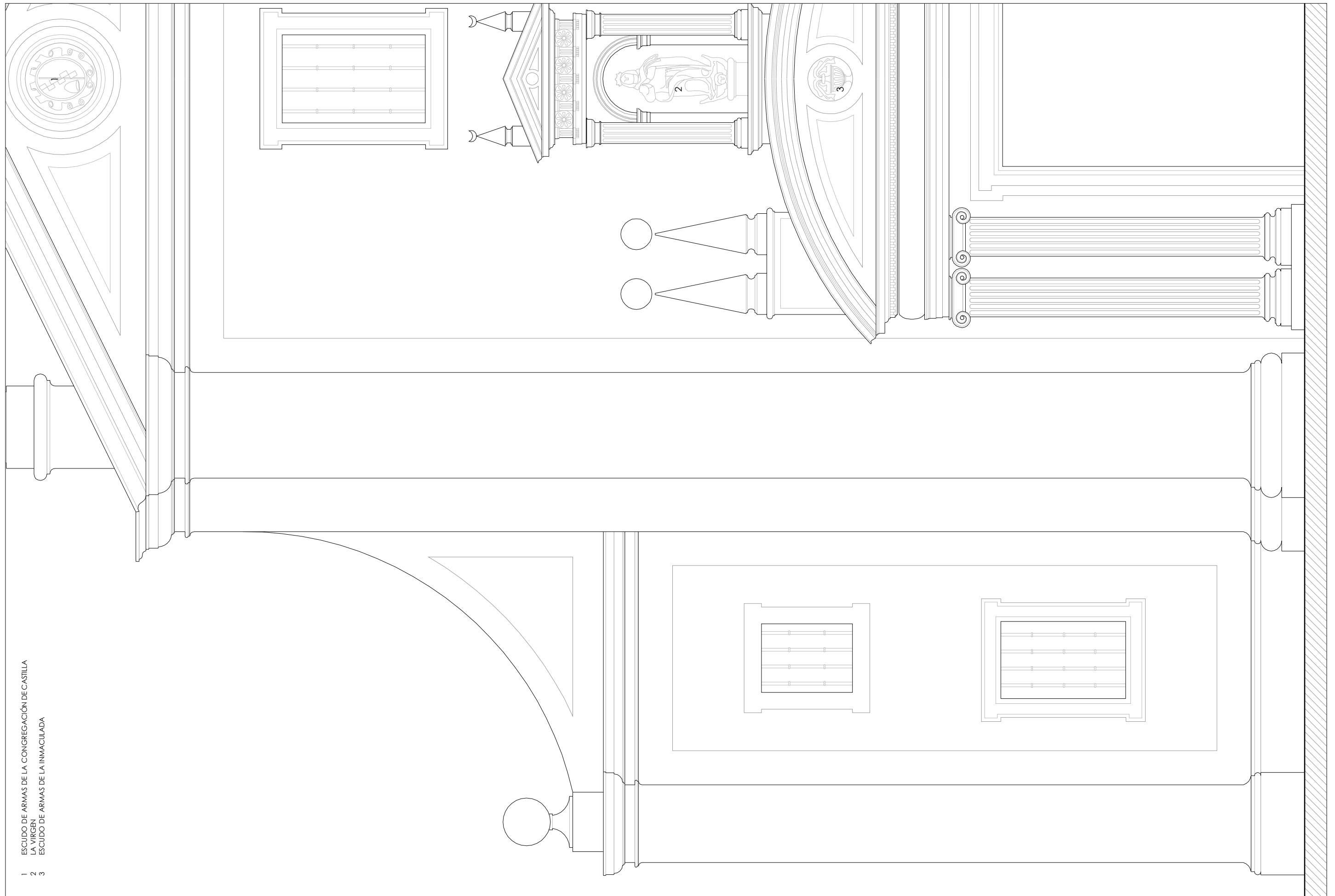

1 ESCUDO DE ARMAS DE LA CONGREGACIÓN DE CASTILLA
 2 LA VIRGEN
 3 ESCUDO DE ARMAS DE LA INMACULADA

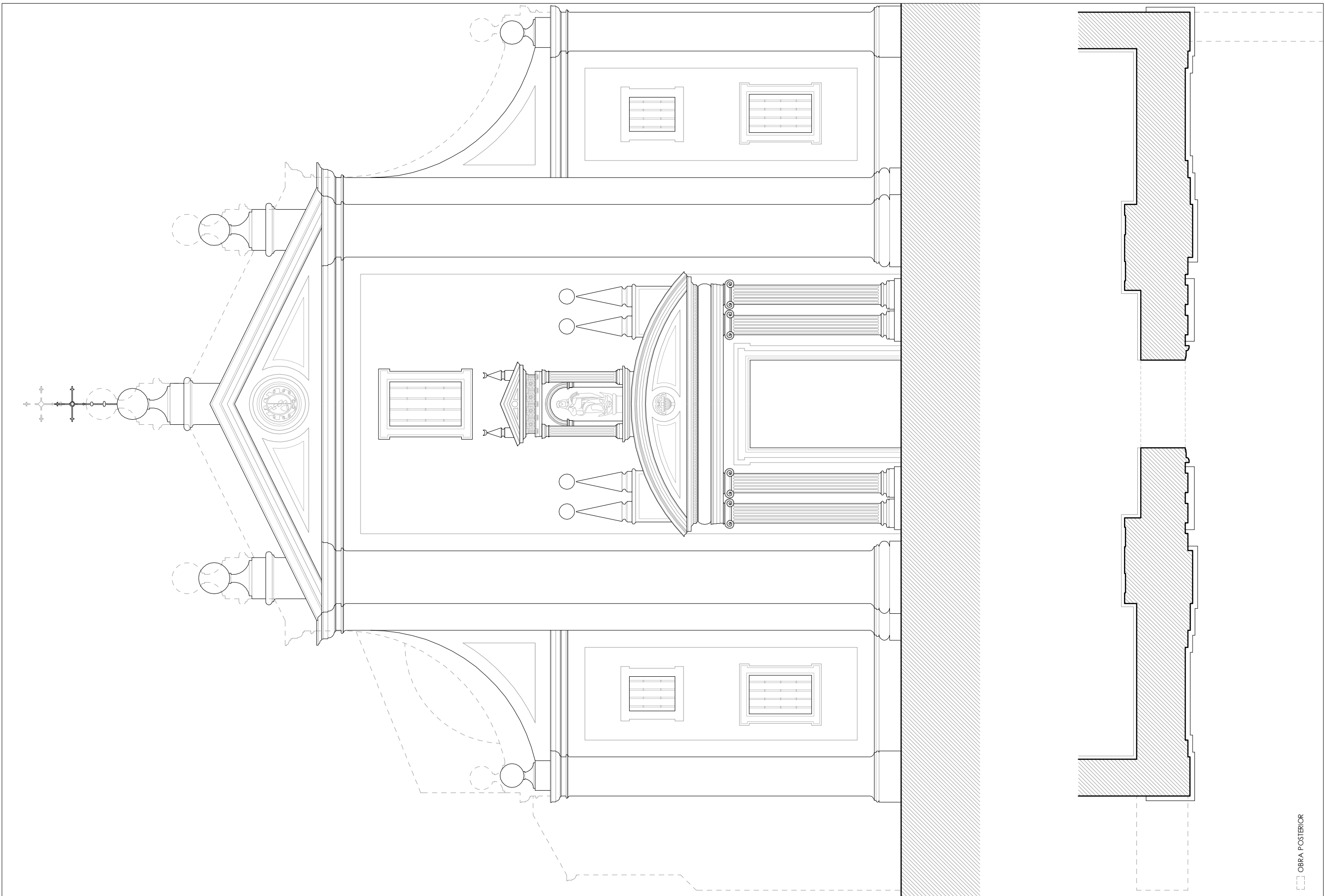

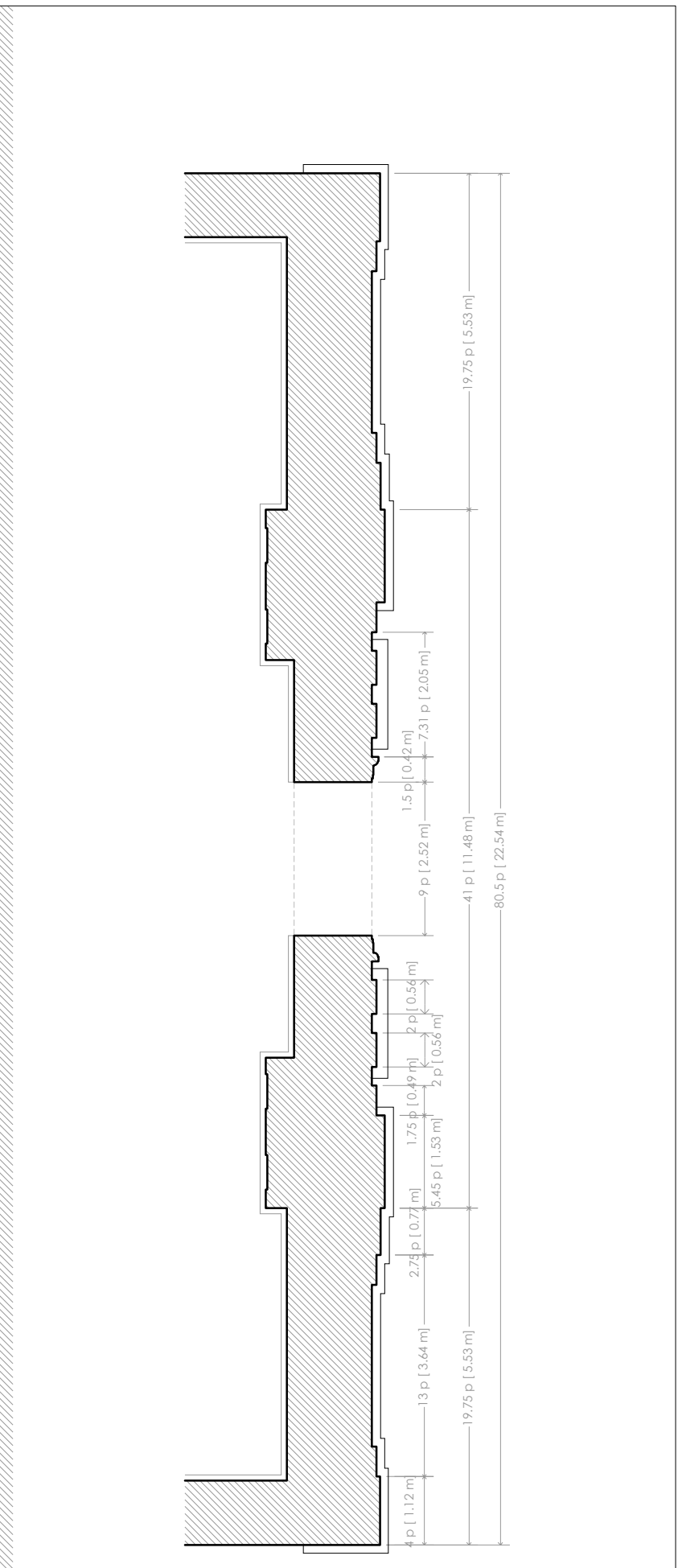
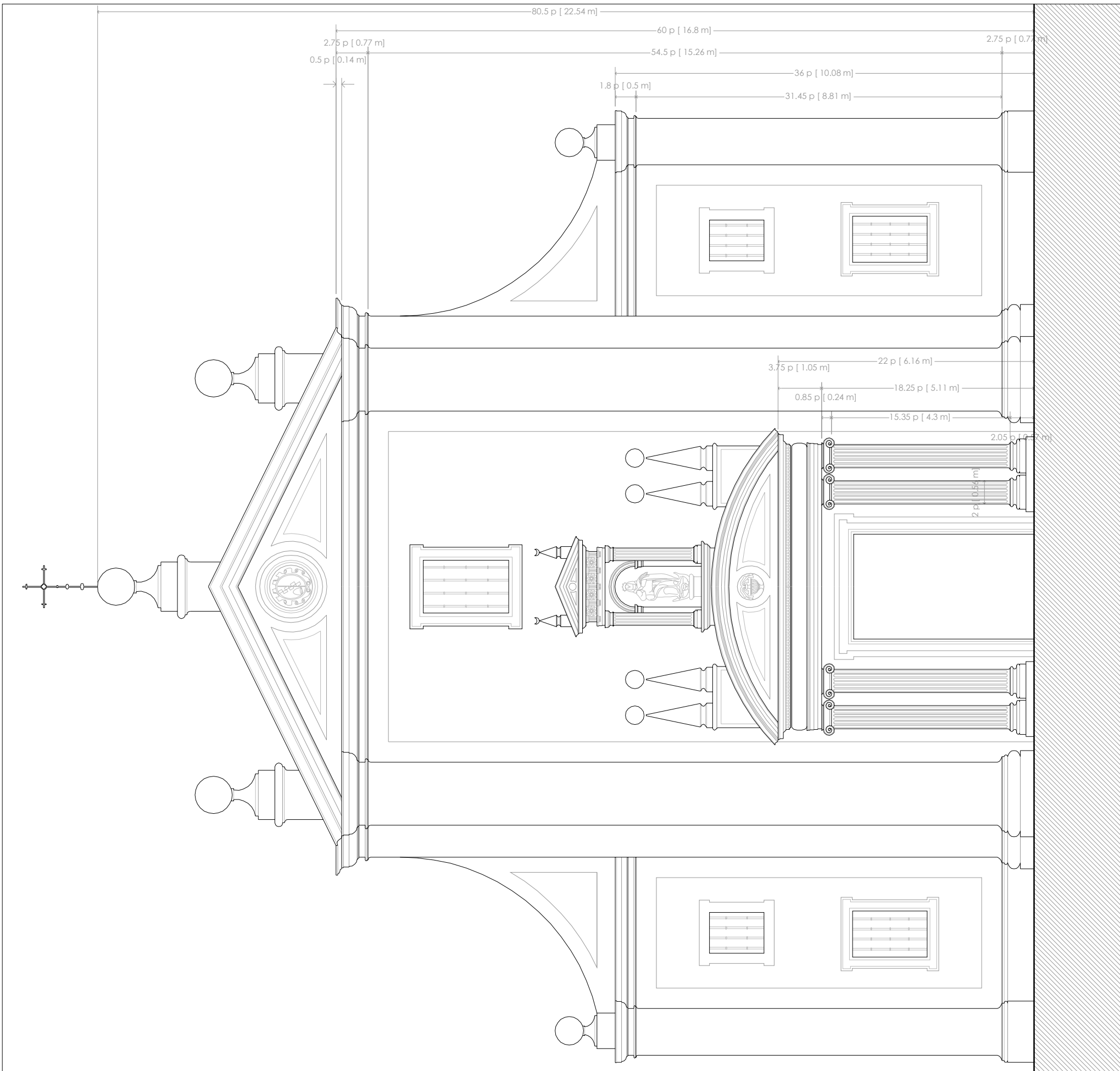

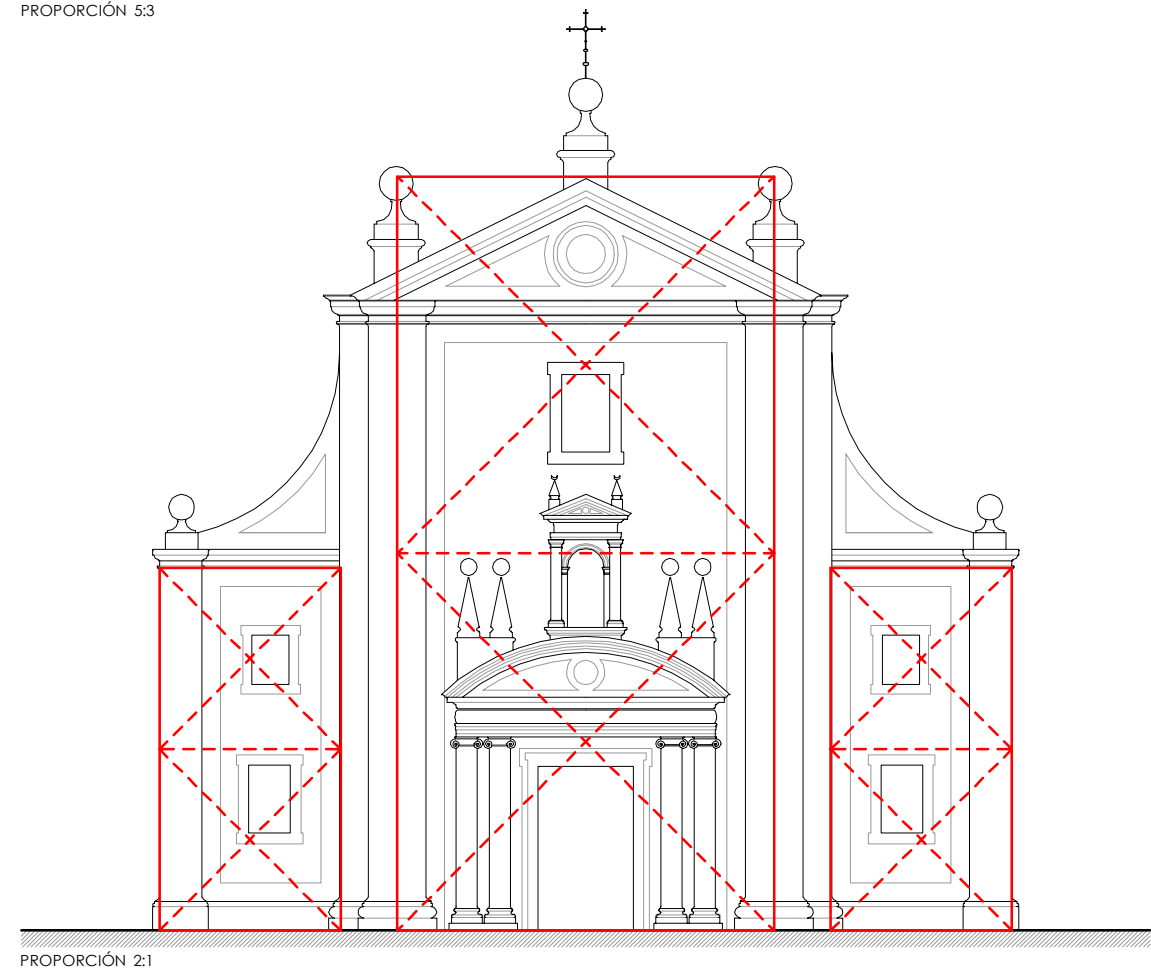
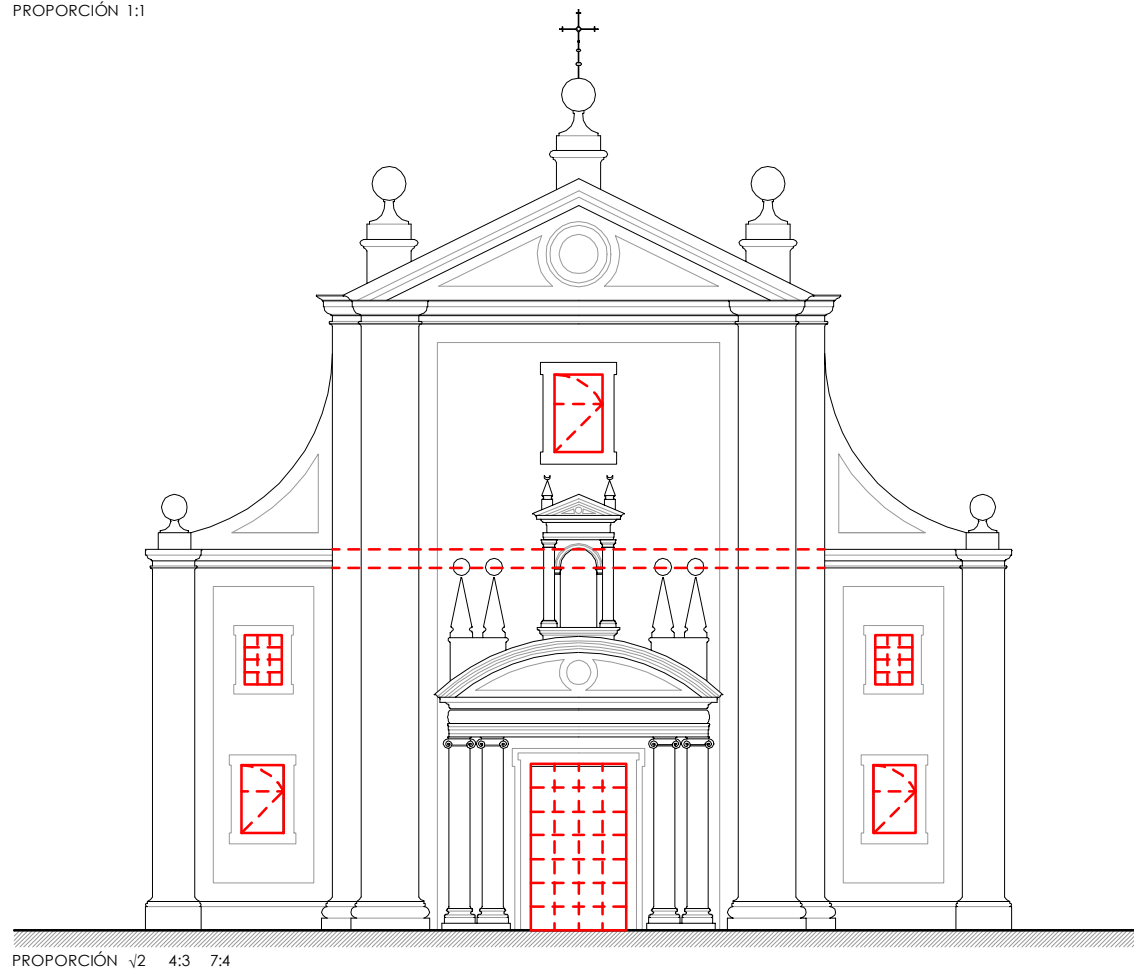
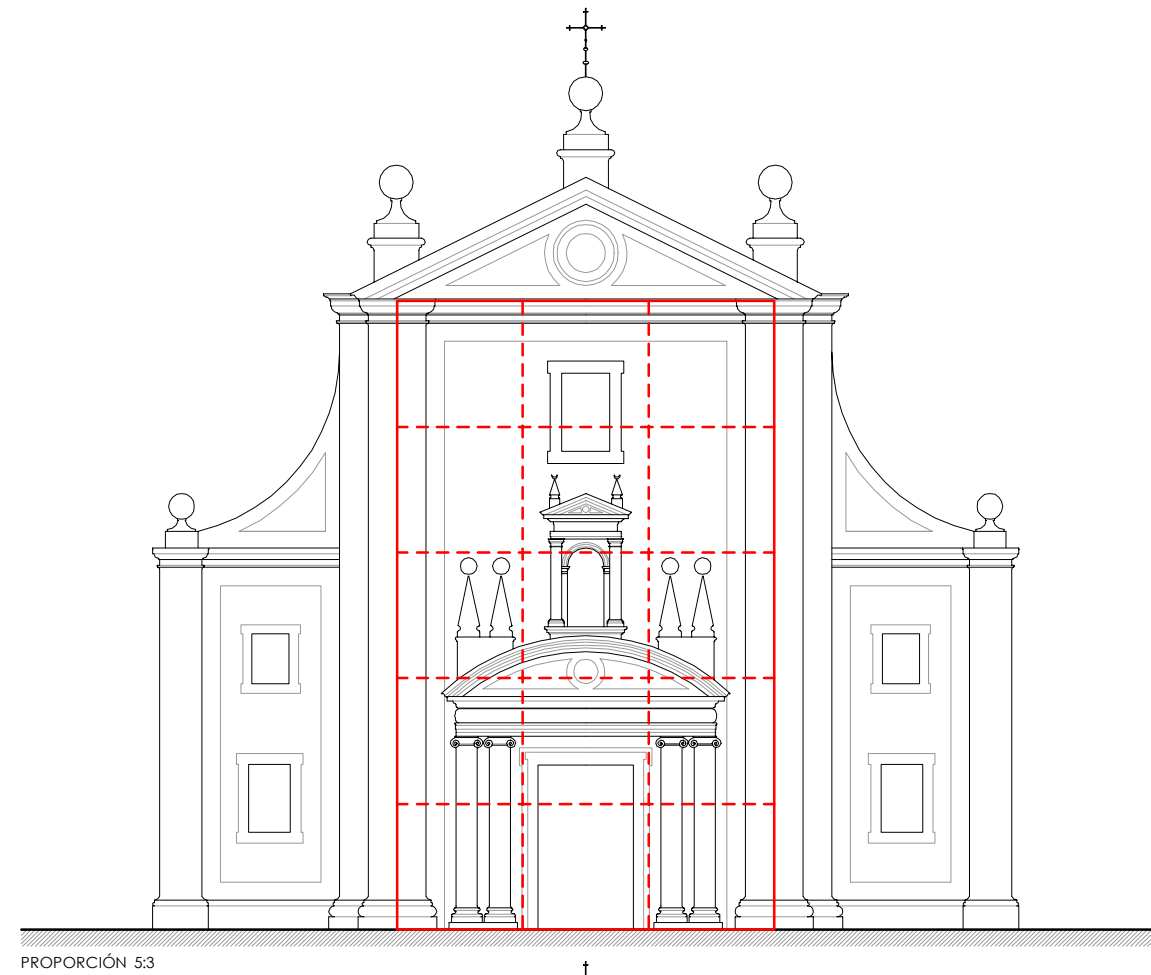
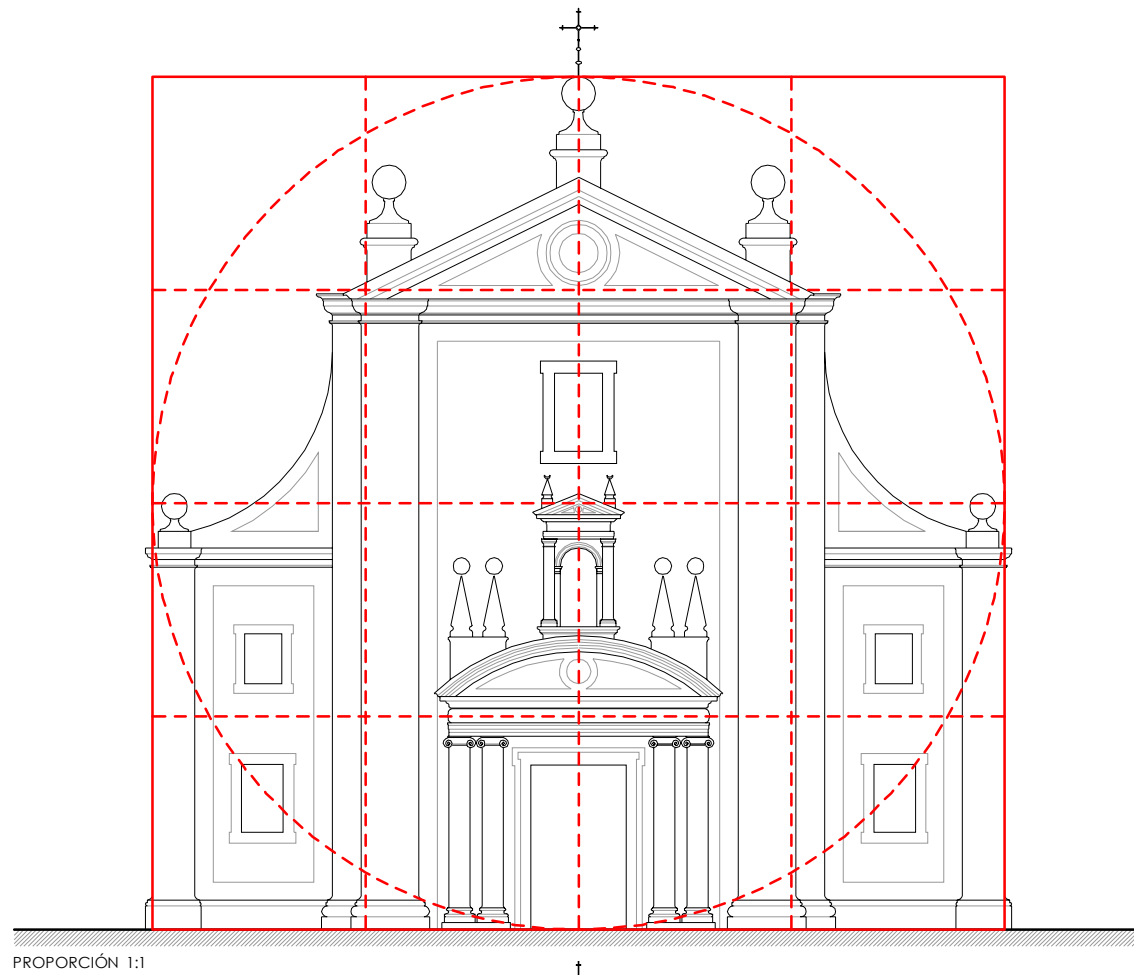

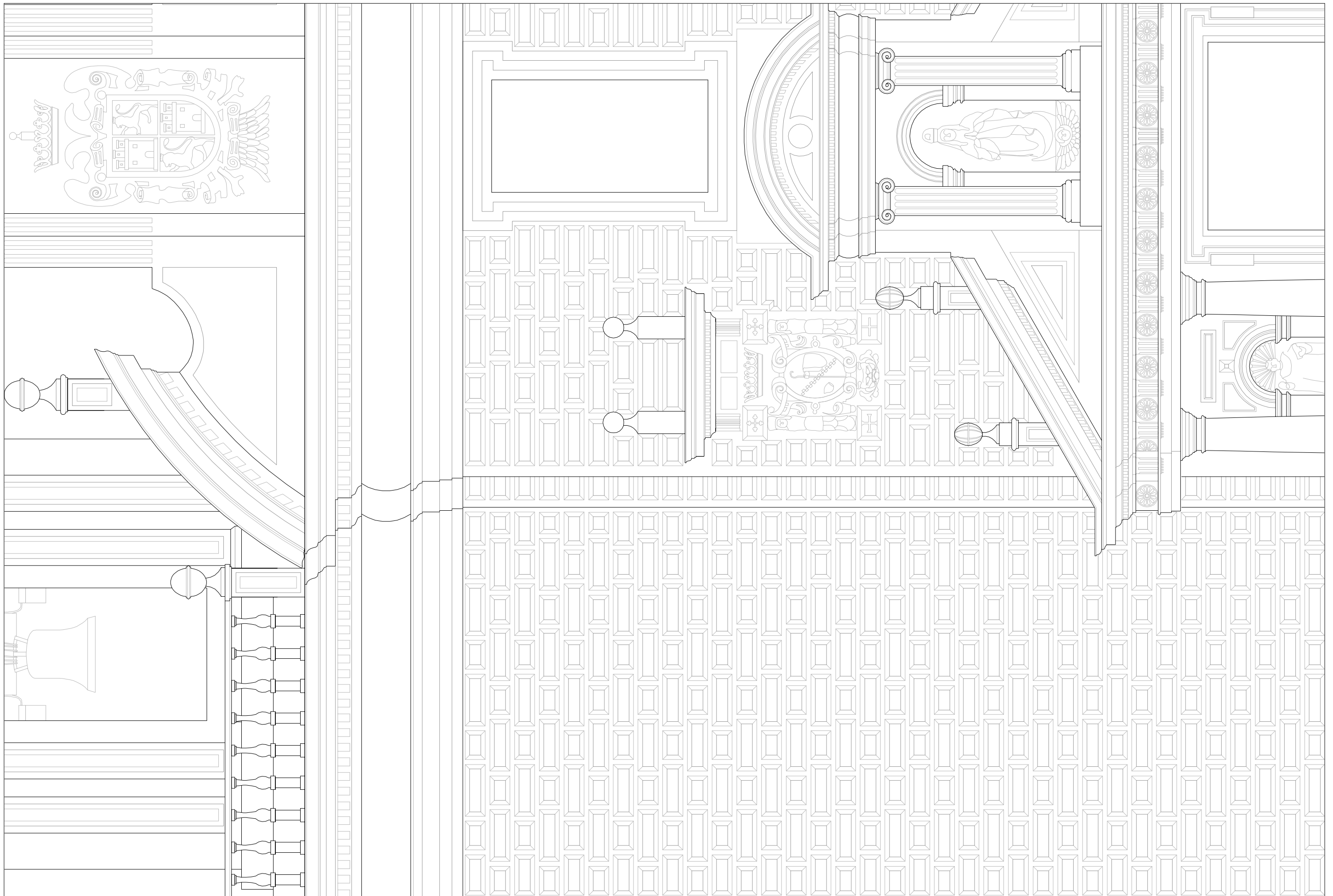

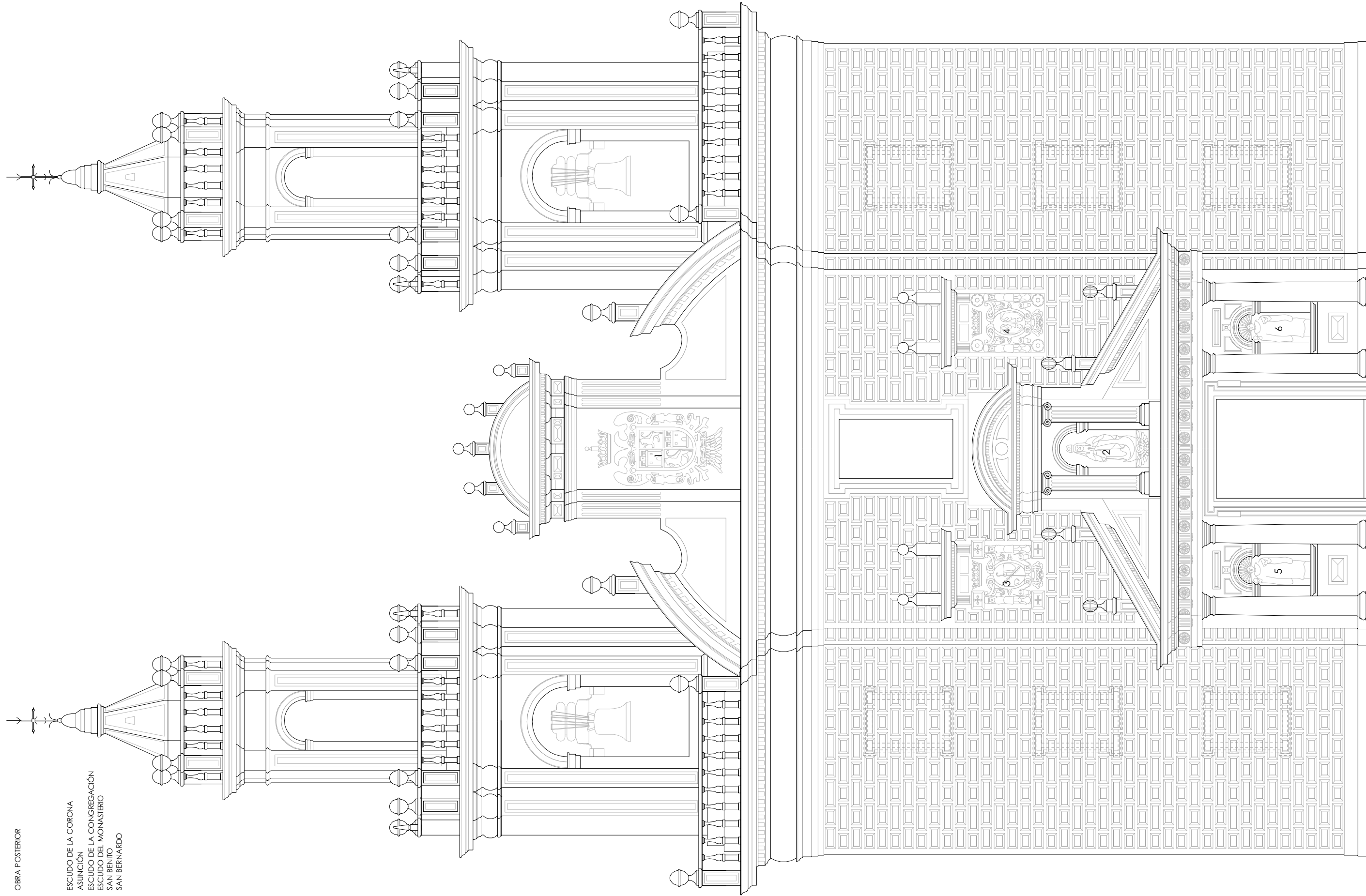

OBRA POSTERIOR

- 1 ESCUDO DE LA CORONA
- 2 ASUNCIÓN
- 3 ESCUDO DE LA CONGREGACIÓN
- 4 ESCUDO DEL MONASTERIO
- 5 SAN BENITO
- 6 SAN BERNARDO

FACHADAS

FACHADA DE LA IGLESIA DEL MONASTERIO DE STA Mª EN OSEIRA

ALZADO Y PLANTA,
DESCRIPCIÓN ICONOGRÁFICA

e: 1/100
1pie: 28.41cm

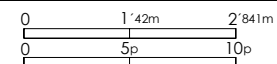

MEDIDAS NO CONFIRMADAS POR RESULTAR INNACESIBLE MEDIR ESTE TRAMO DE LA FÁBRICA

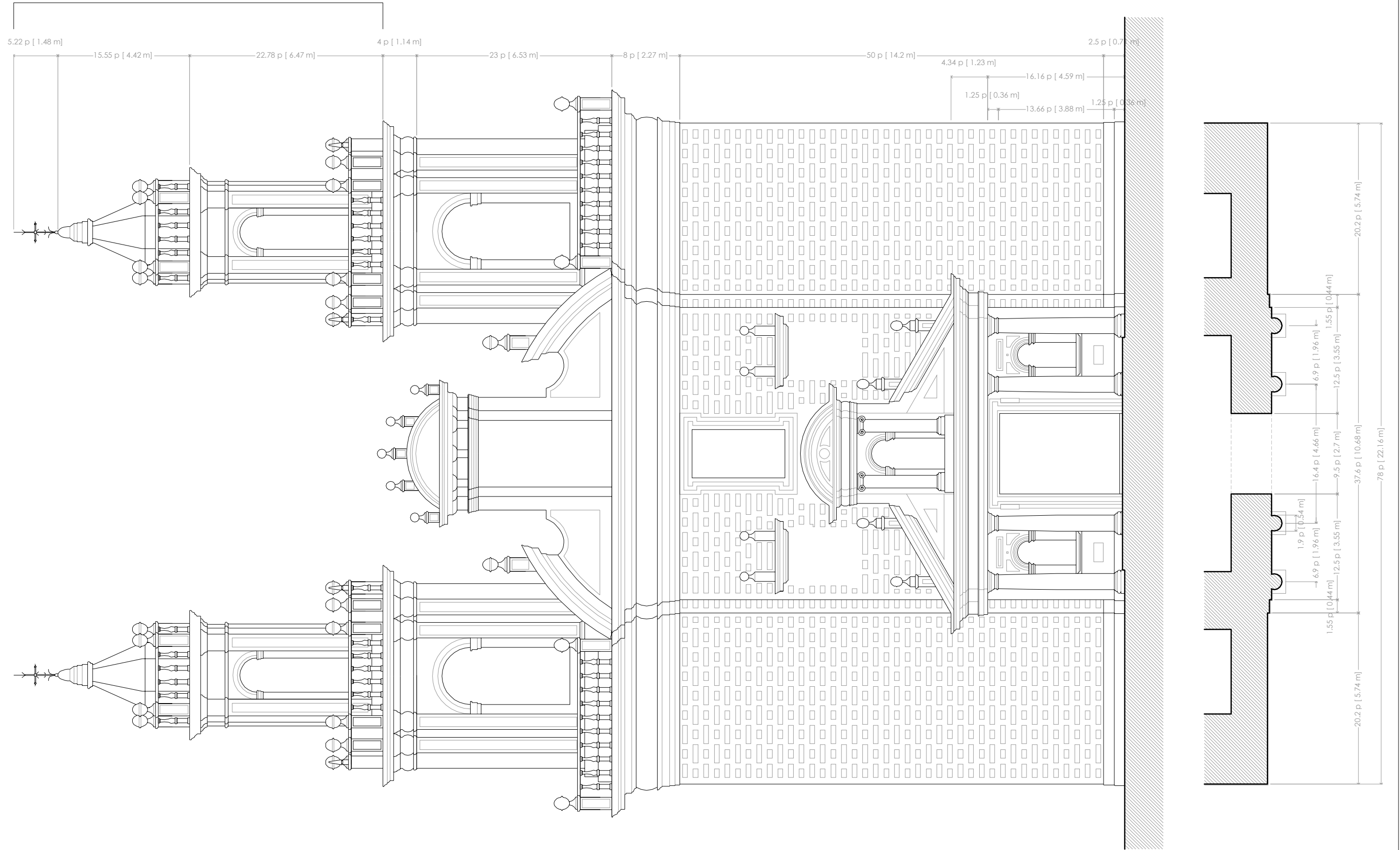

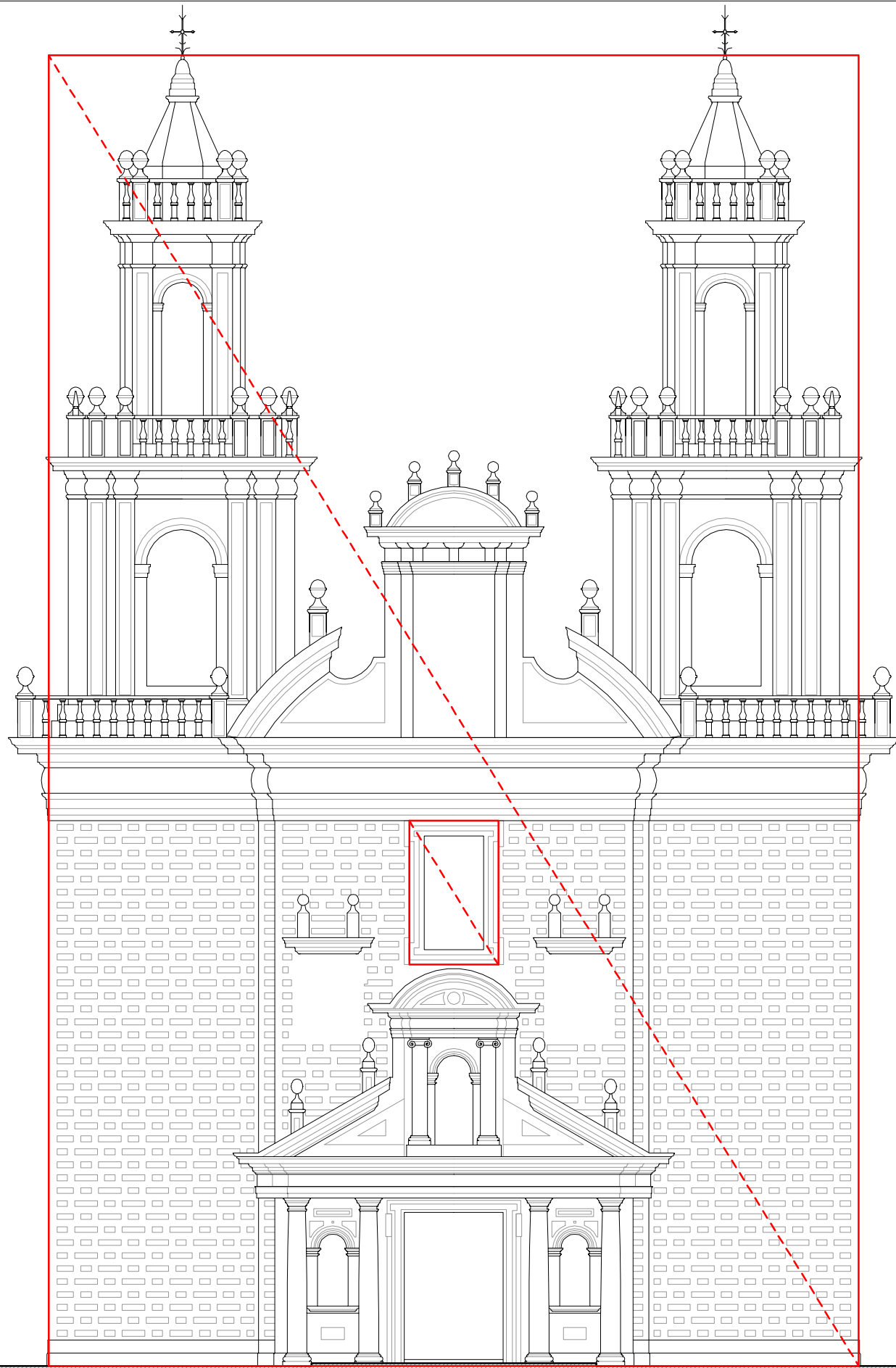

PROPORCIÓN ÁREA

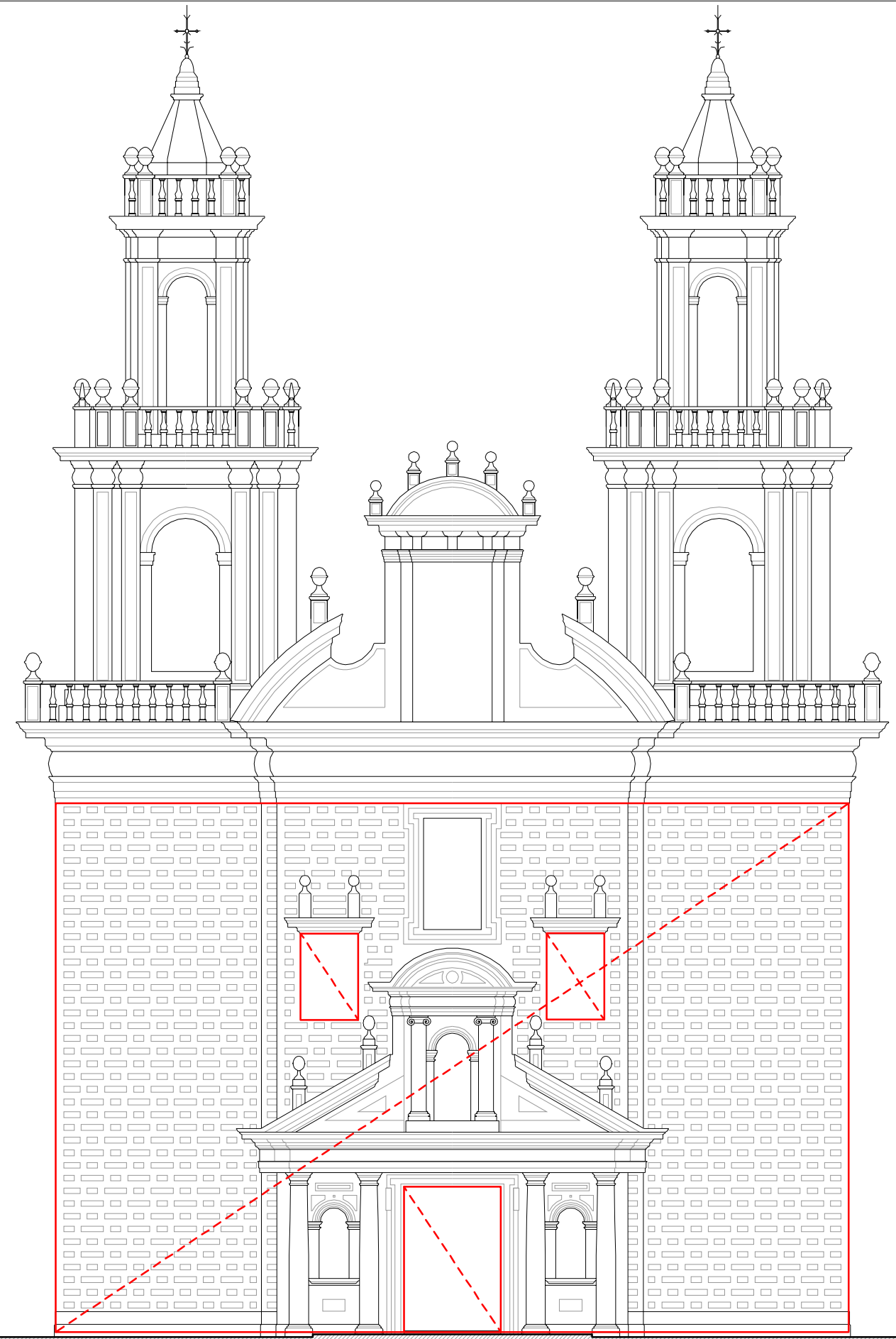

PROPORCIÓN 3:2

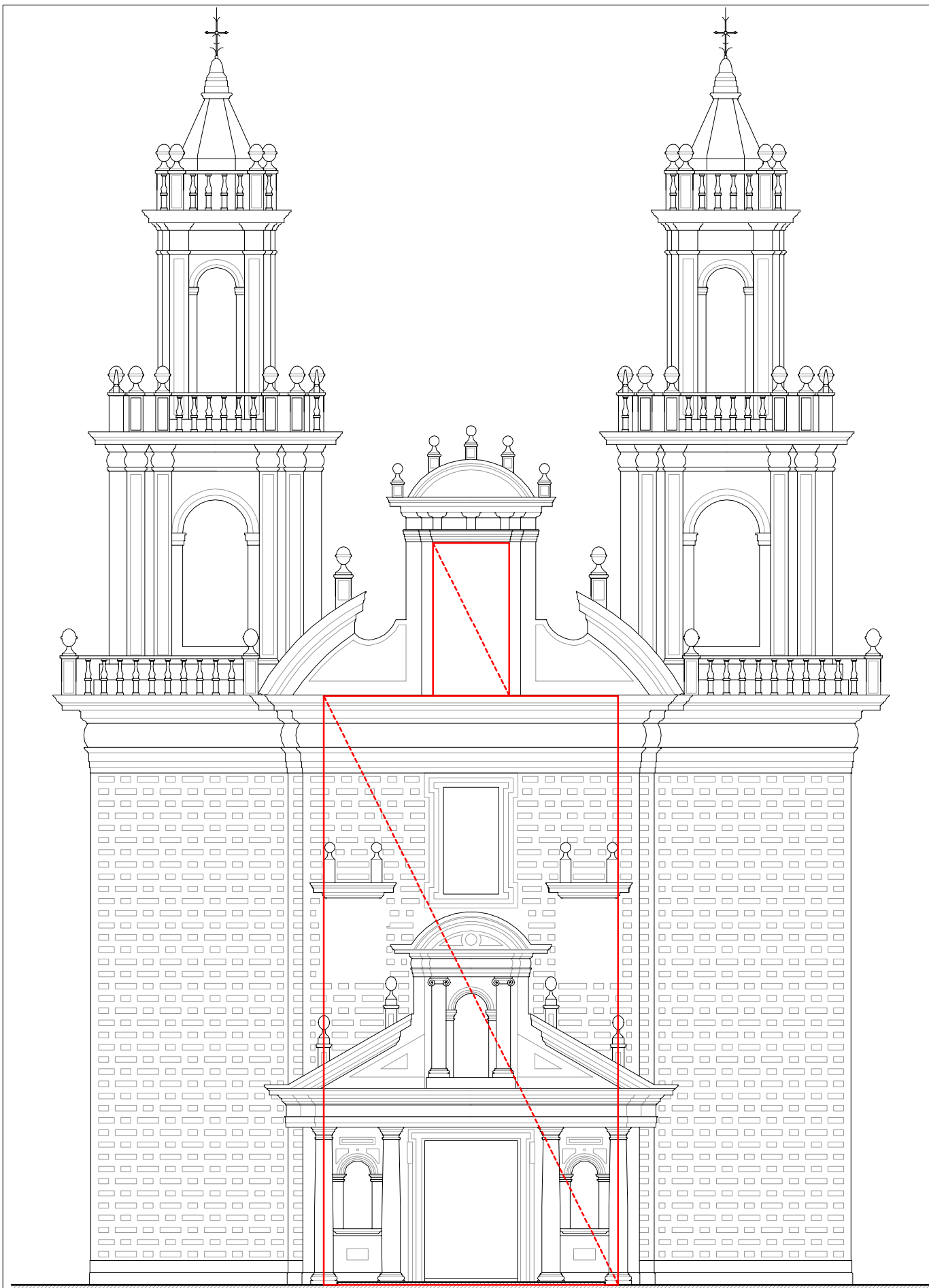

PROPORCIÓN 2:1

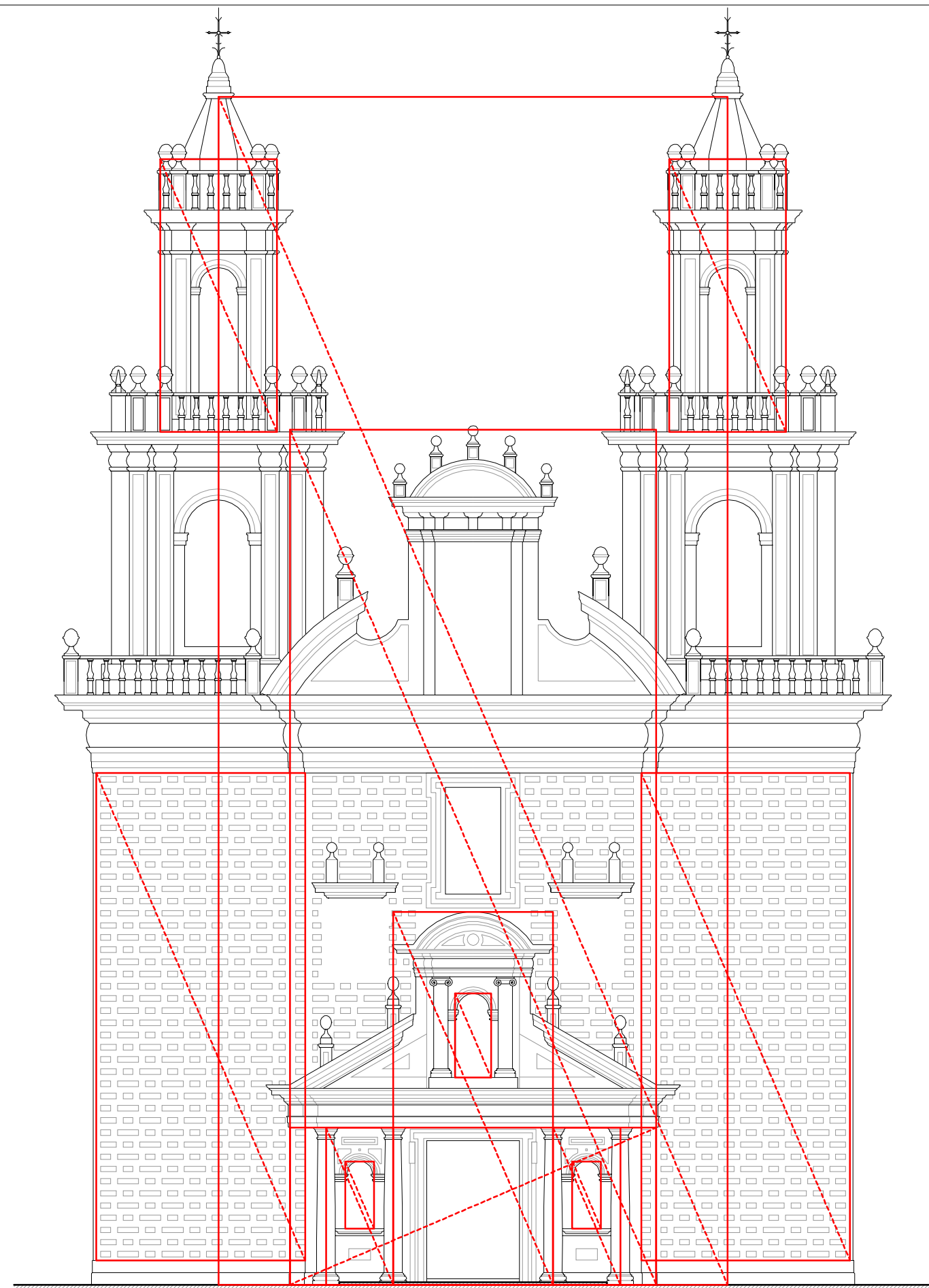

PROPORCIÓN 7:3

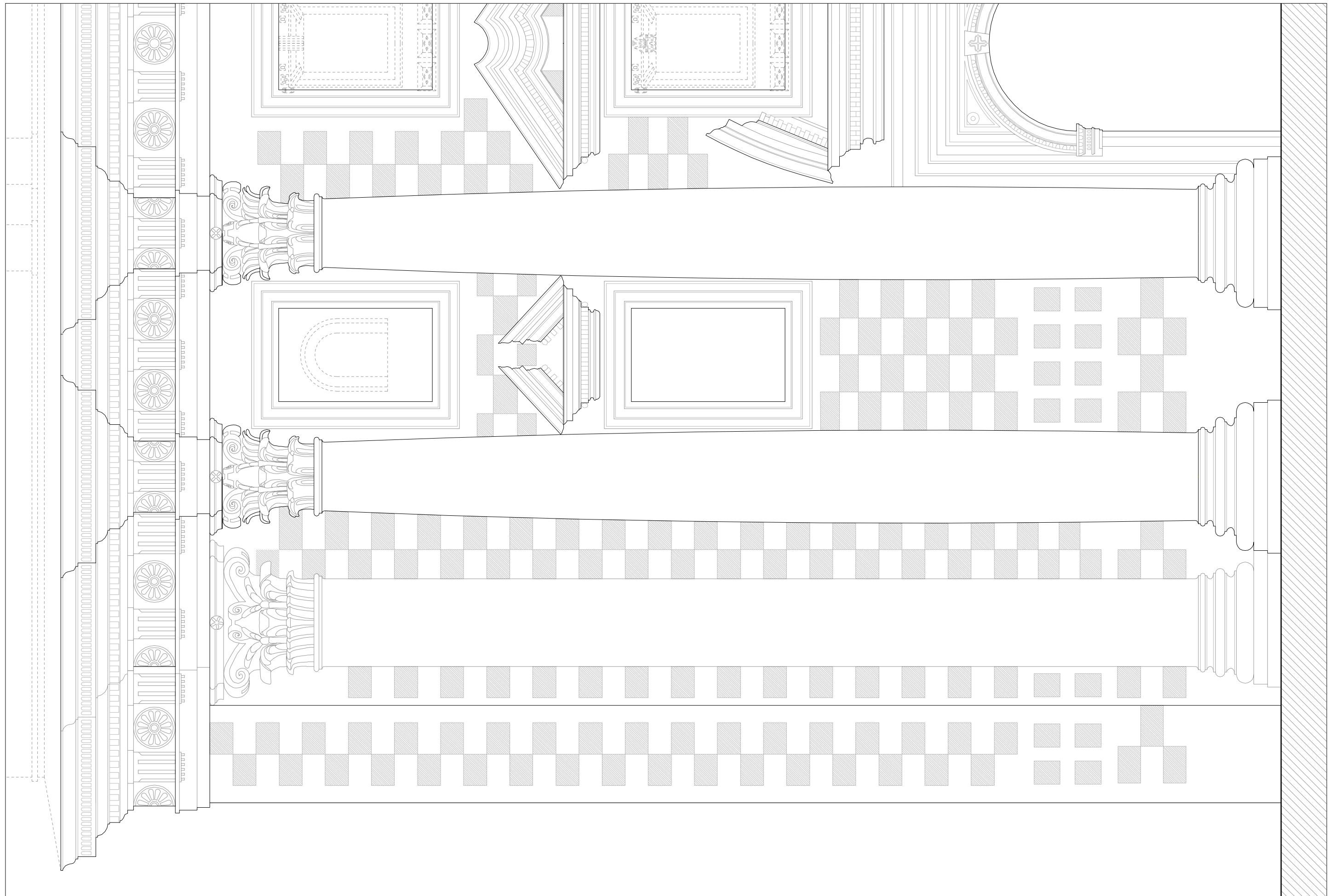

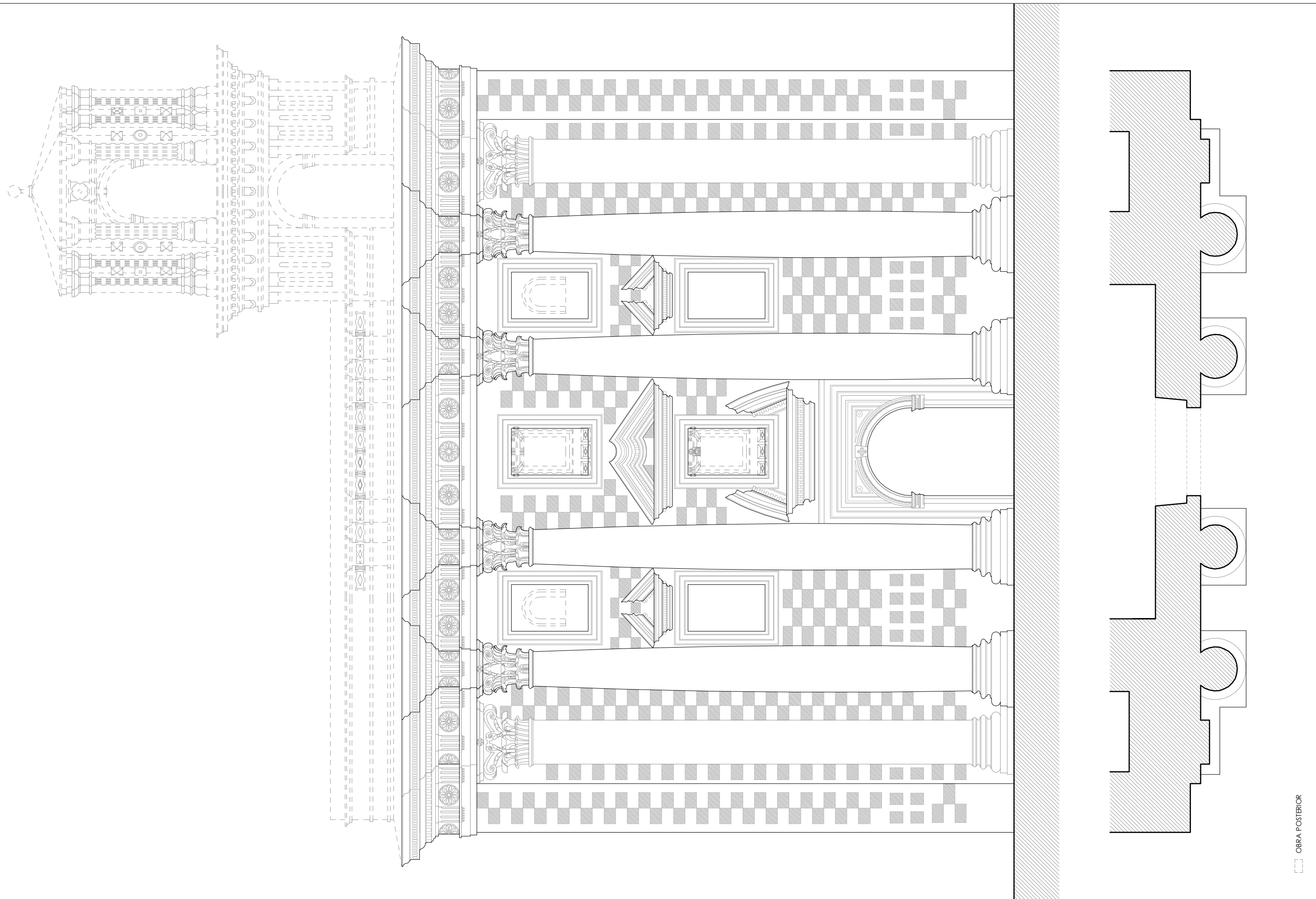

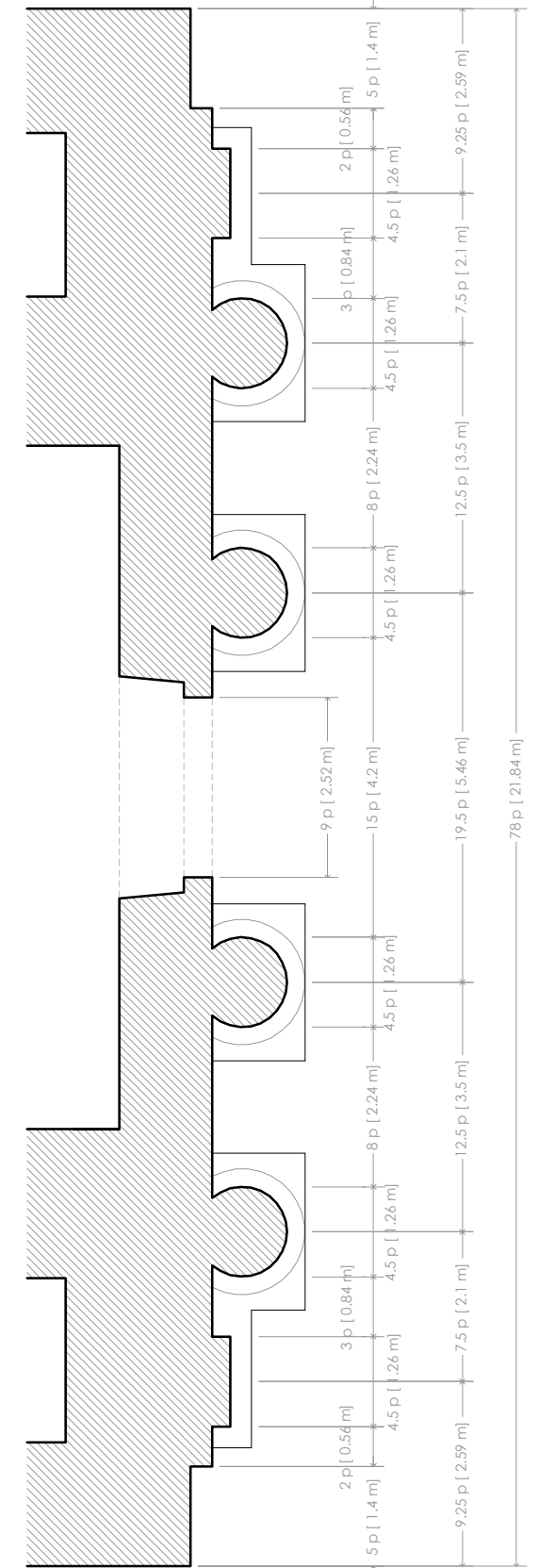
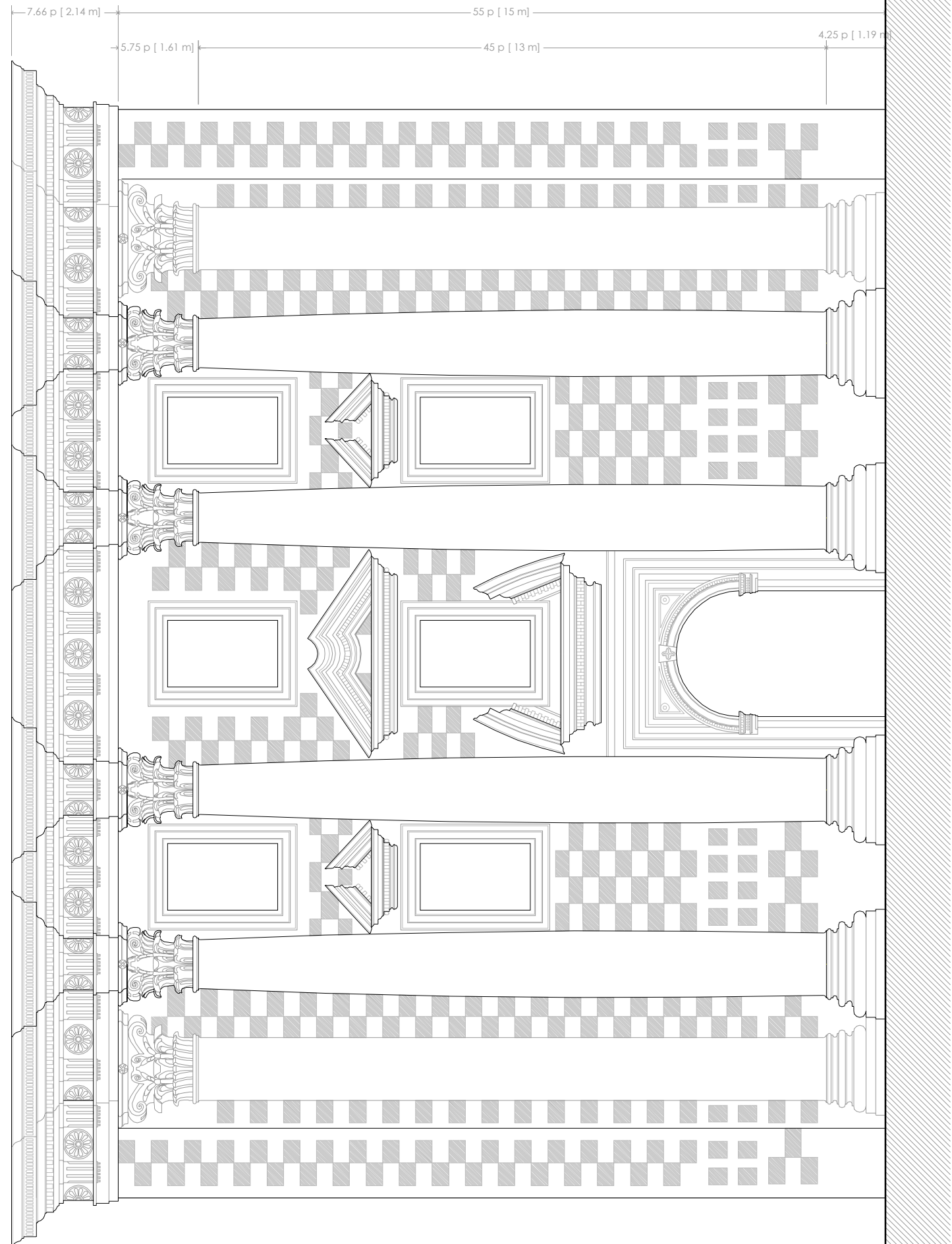

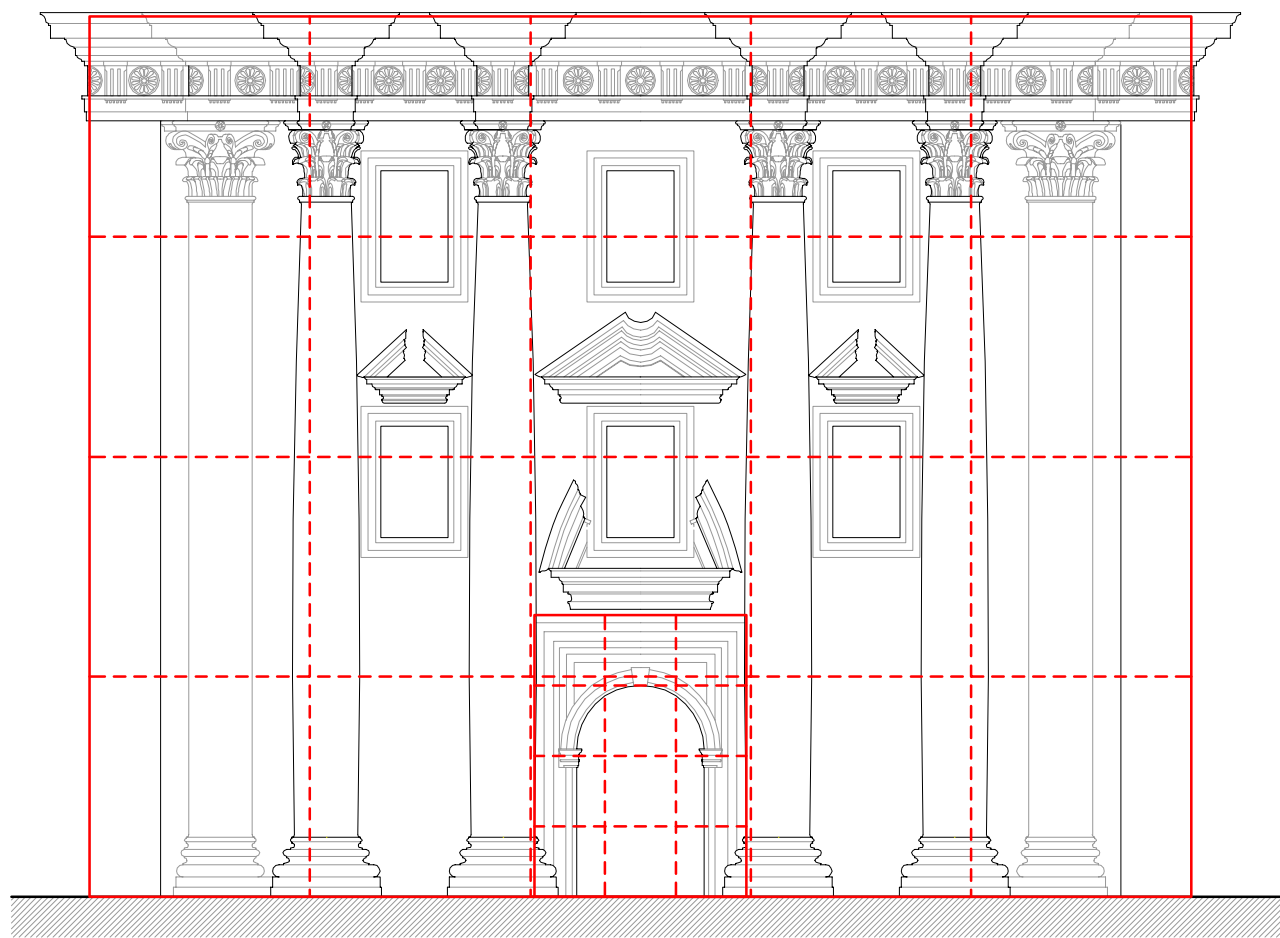

PROPORCIÓN 5:4

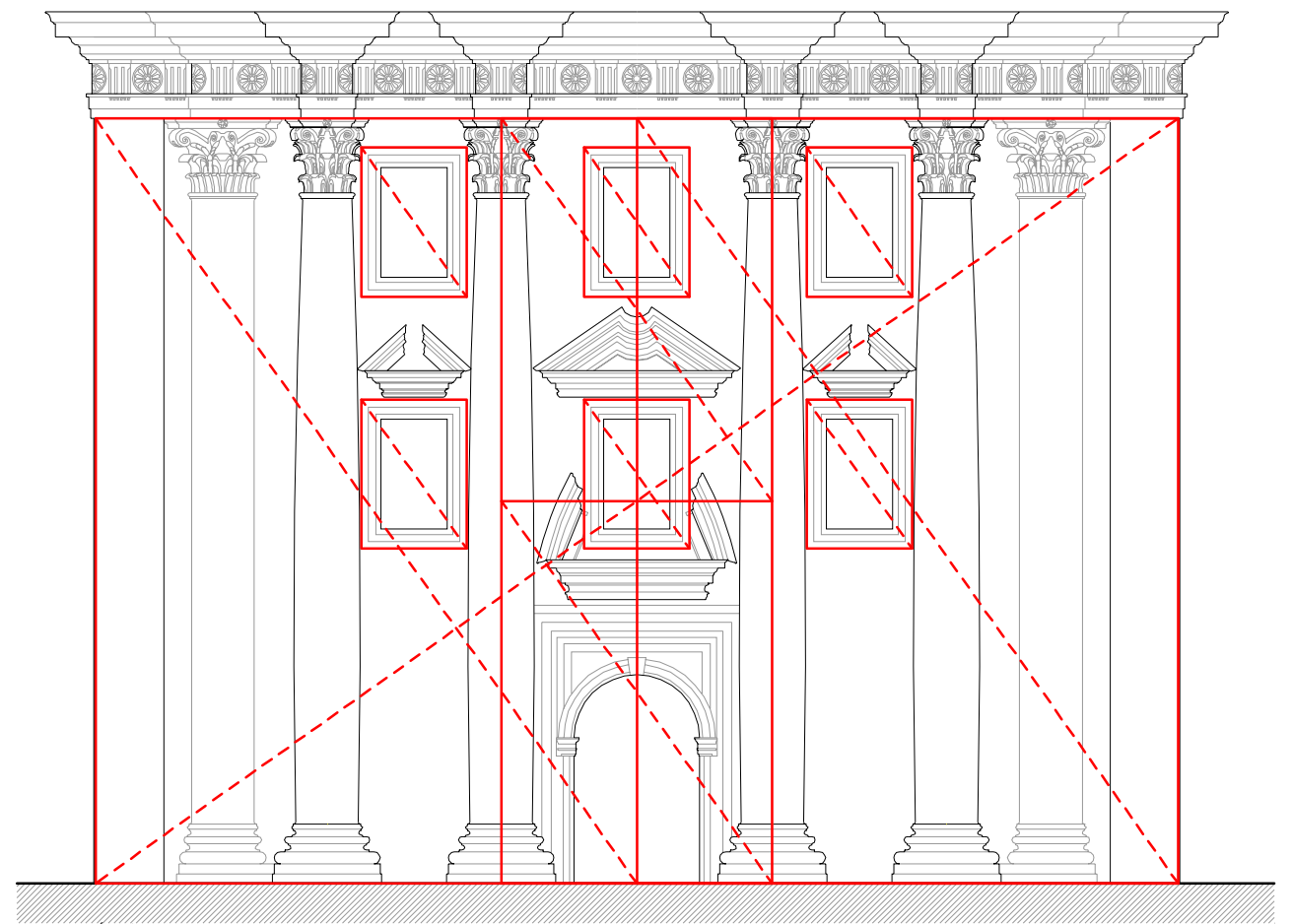

PROPORCIÓN √2

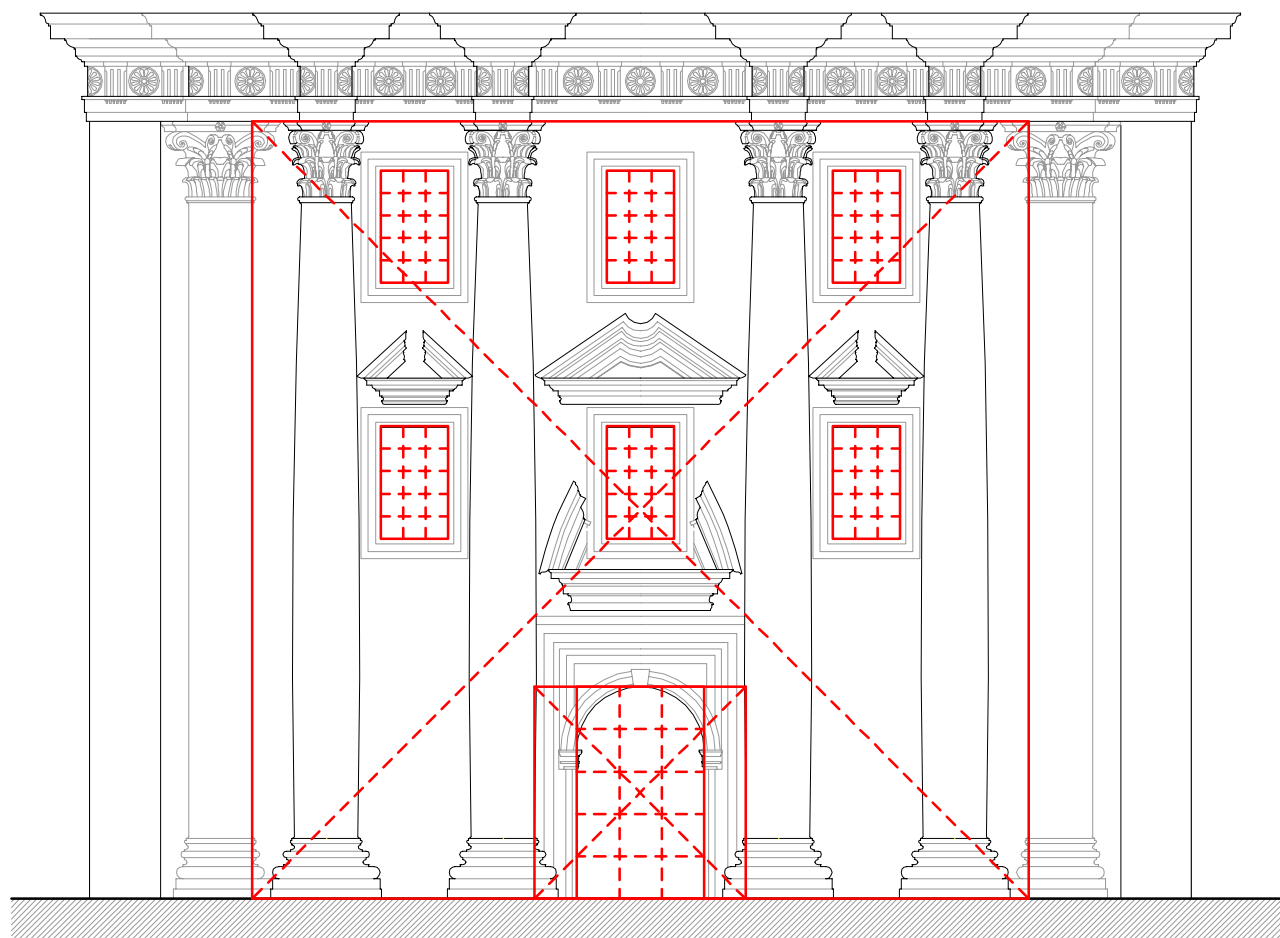

PROPORCIÓN 5:3 1:1

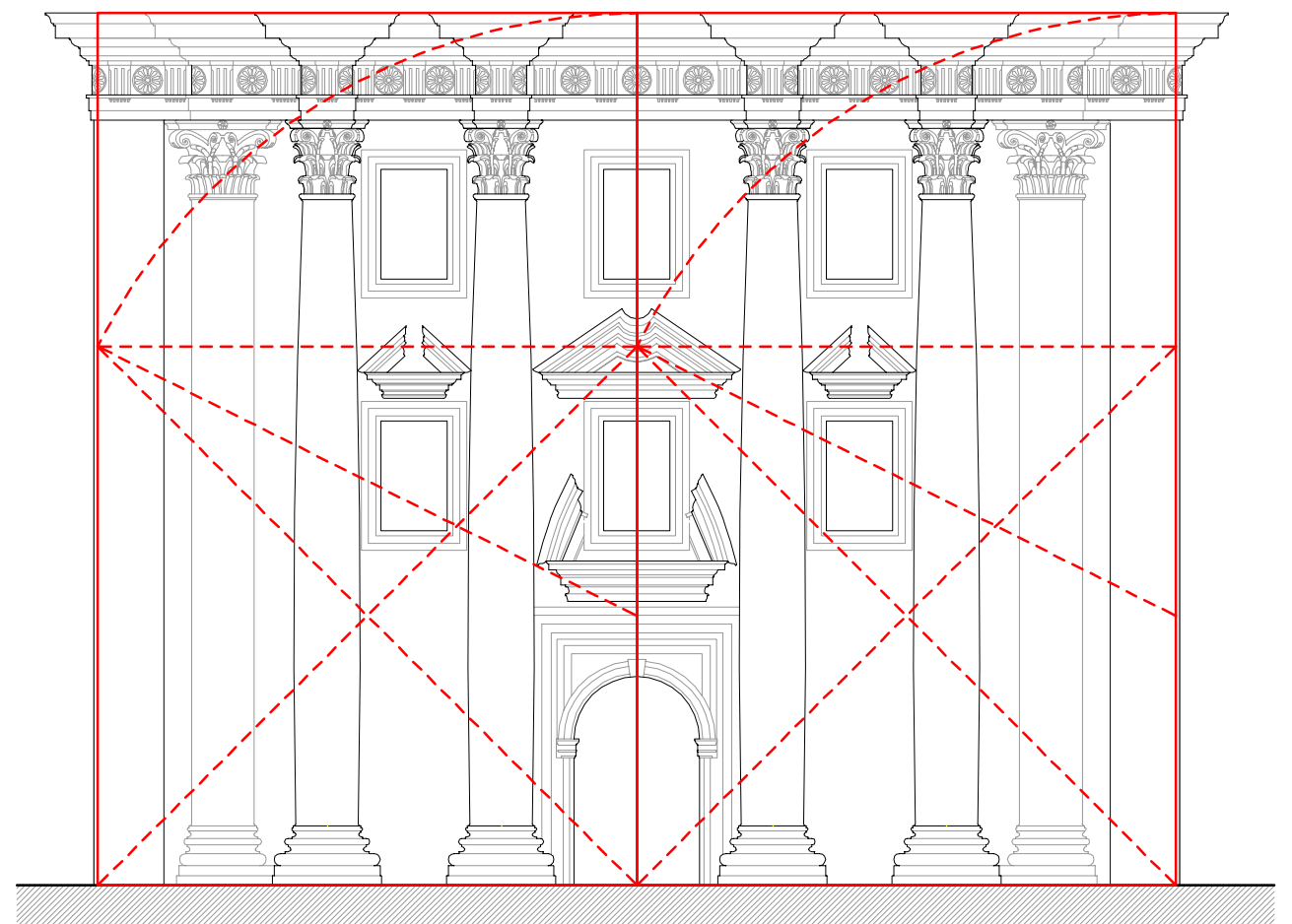

PROPORCIÓN ÁUREA

