

DETALLE CURVATURA ARCOS e:1/75

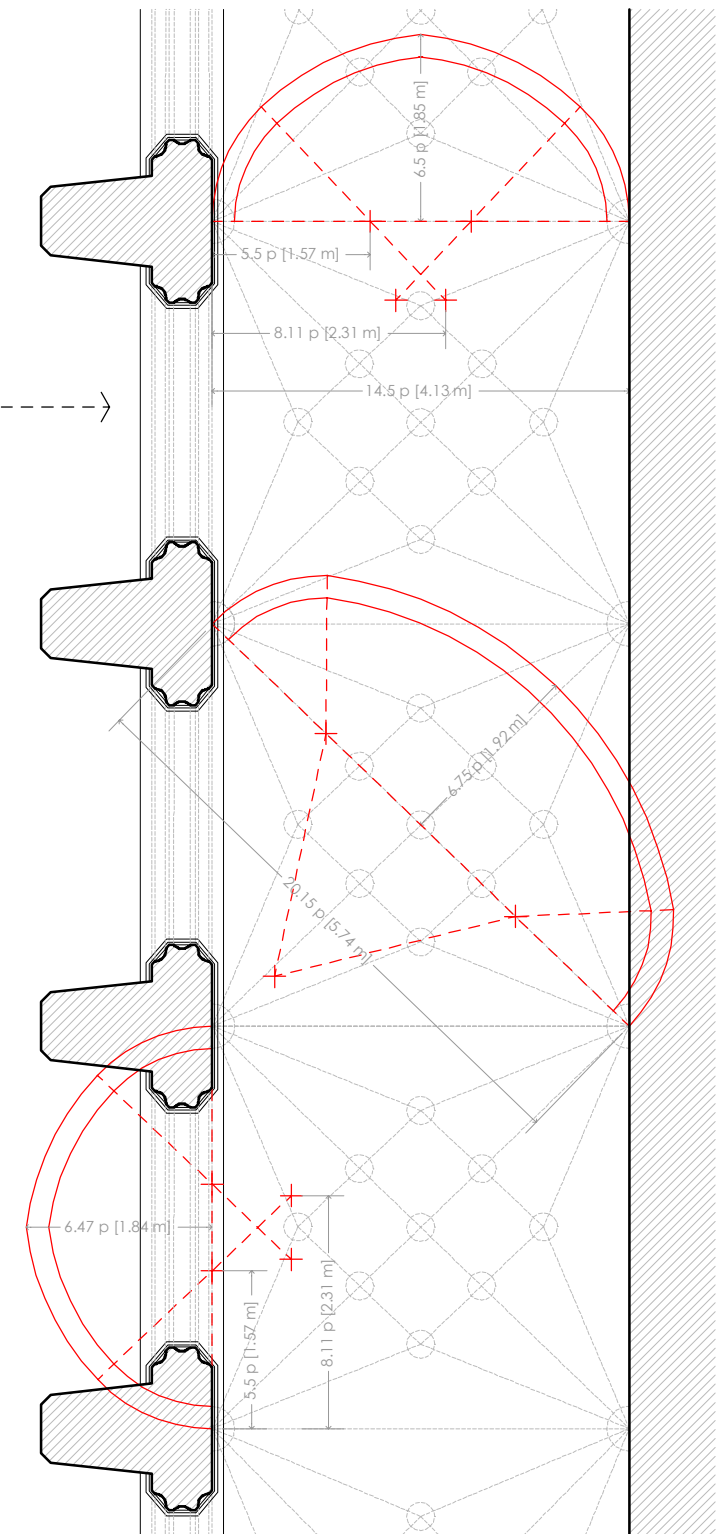

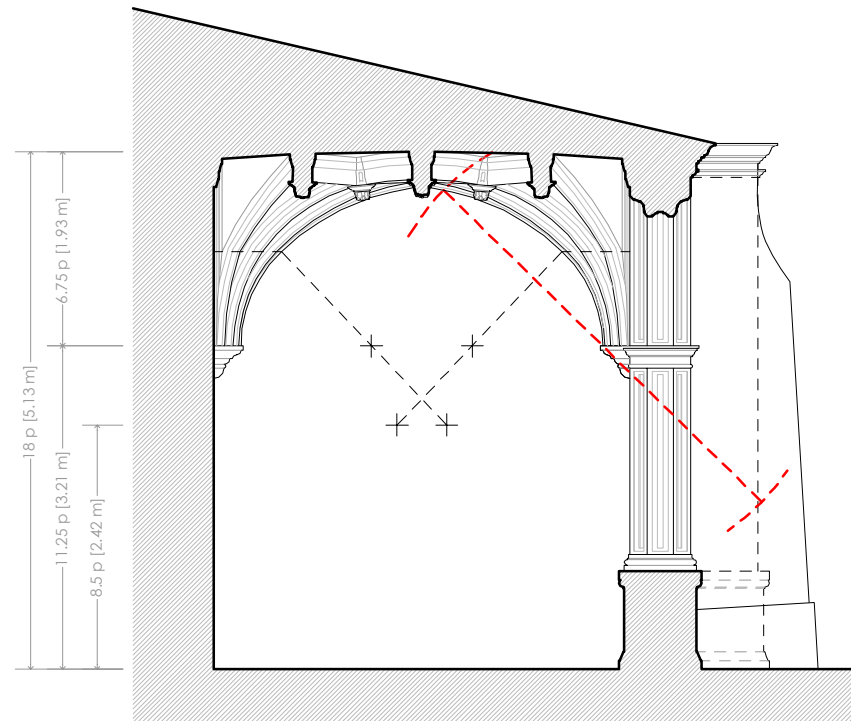

RELACIÓN SECCIÓN CONTAFUERTES PROYECTO-MODIFICACIÓN

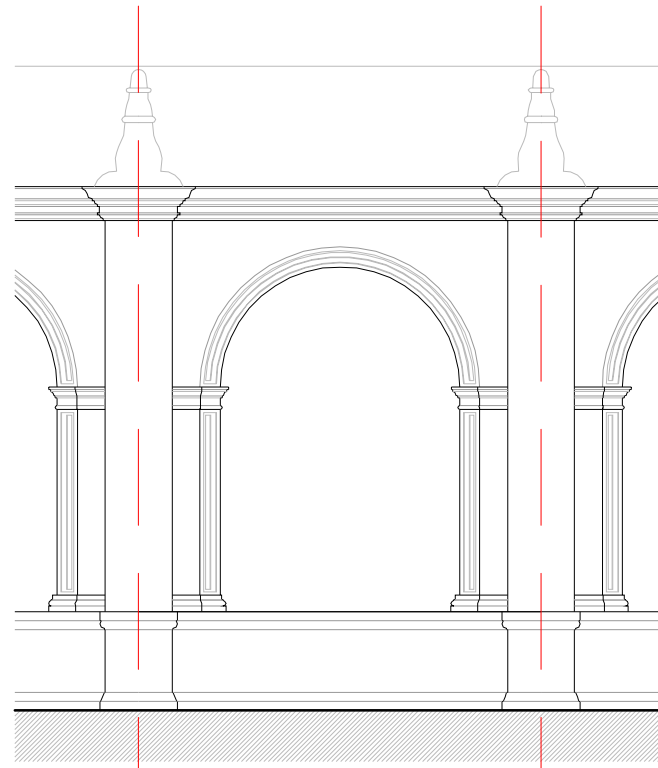

ALZADO PROYECTO (HIPÓTESIS)

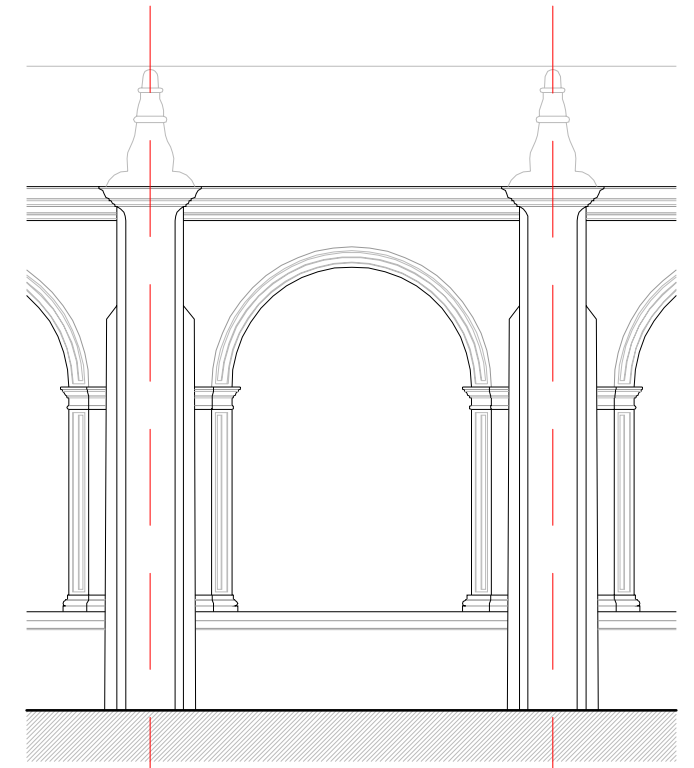

ALZADO MODIFICACIÓN

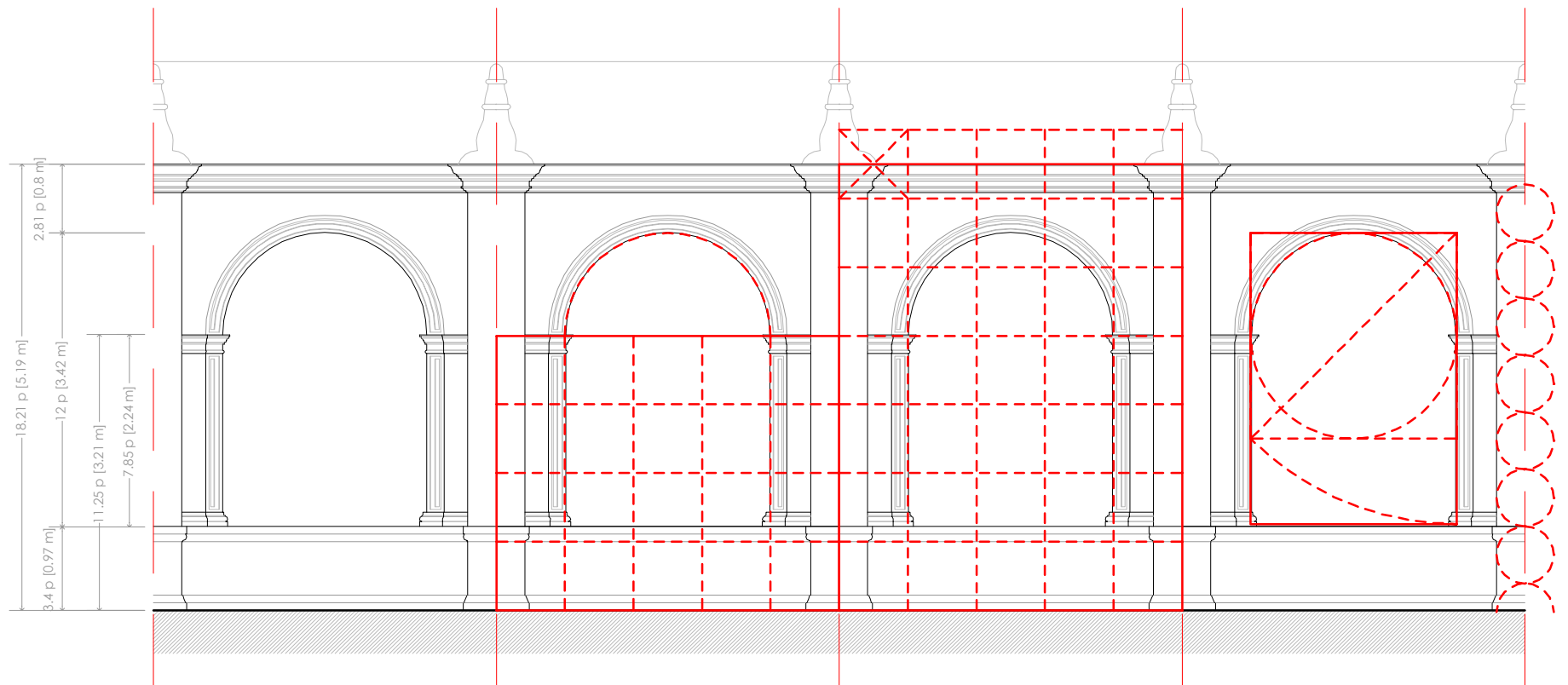
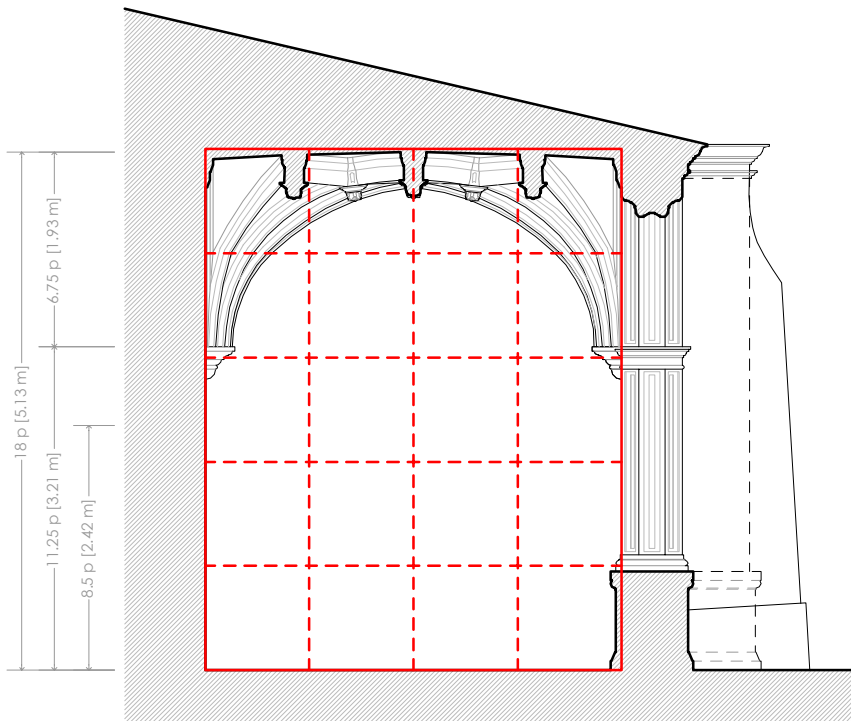

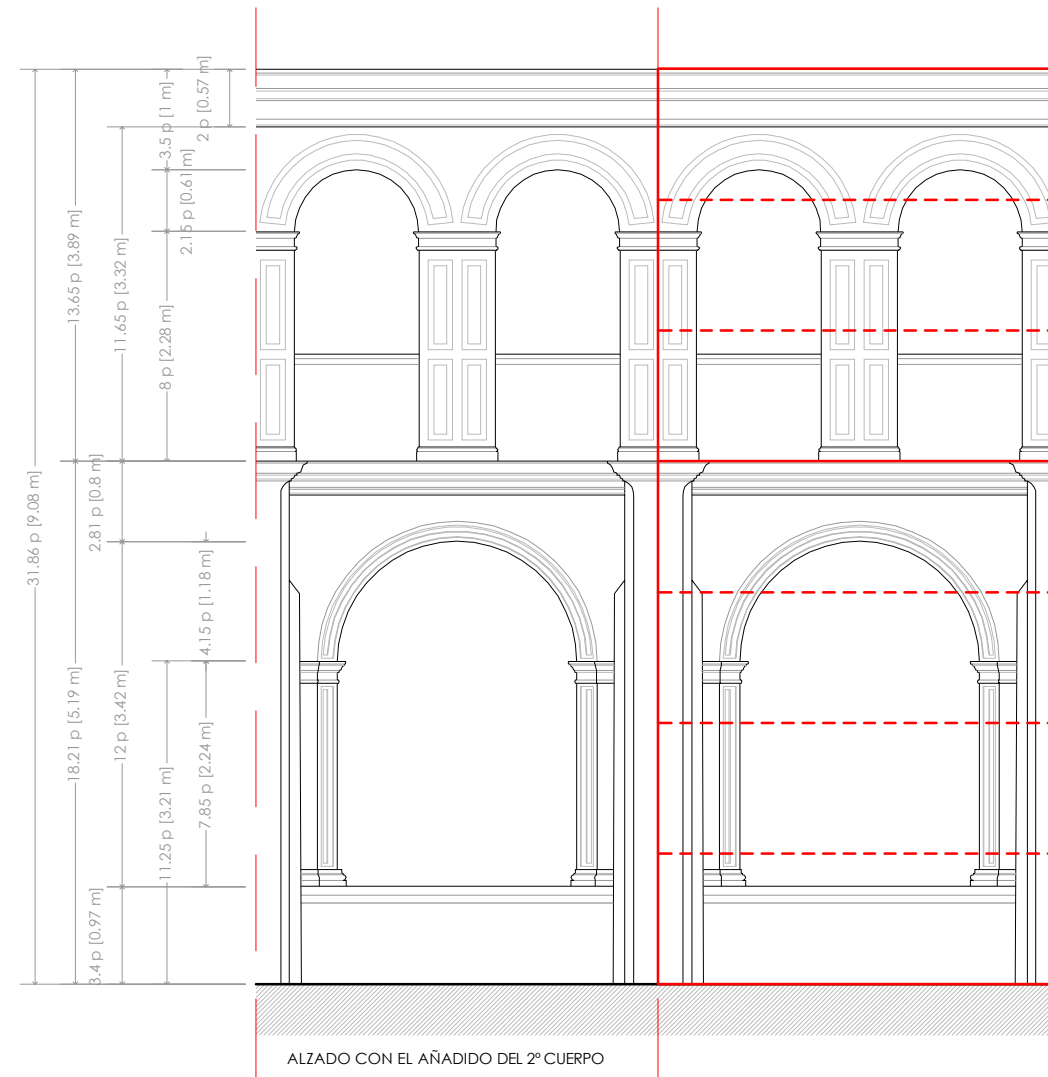
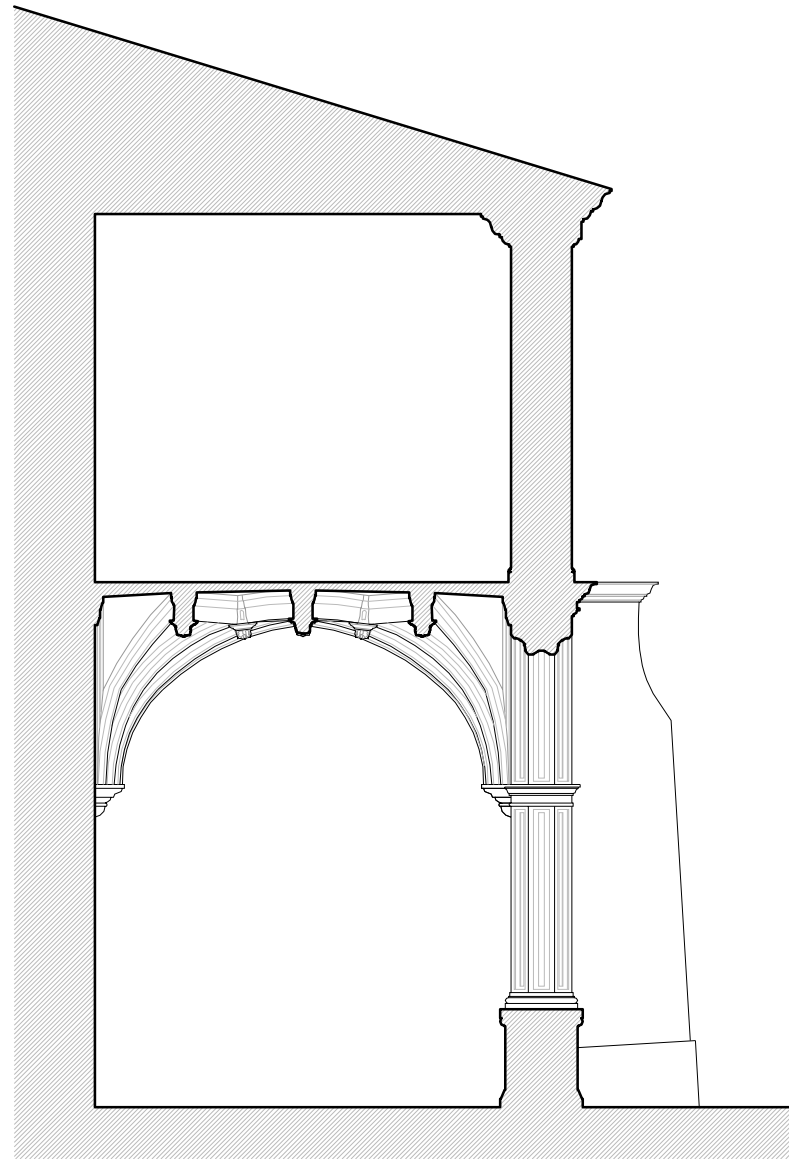

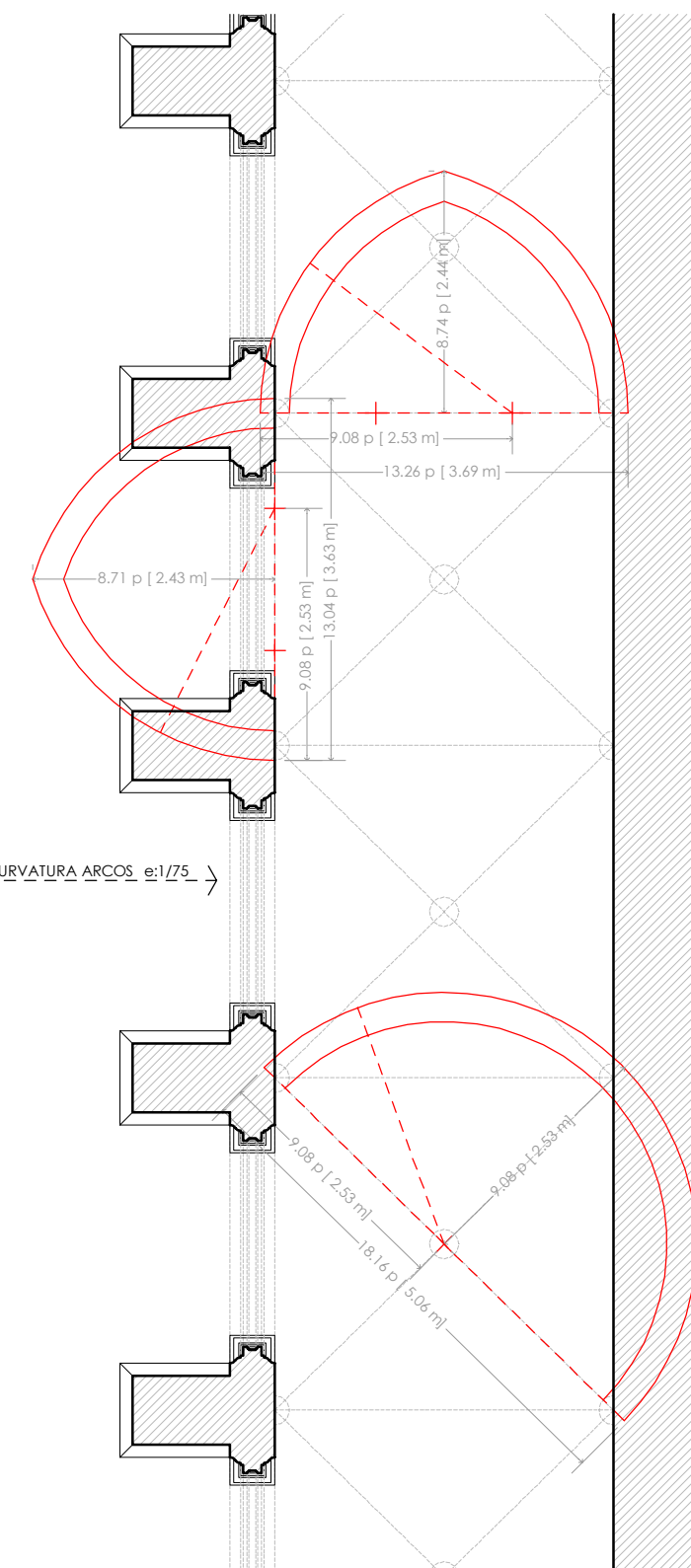
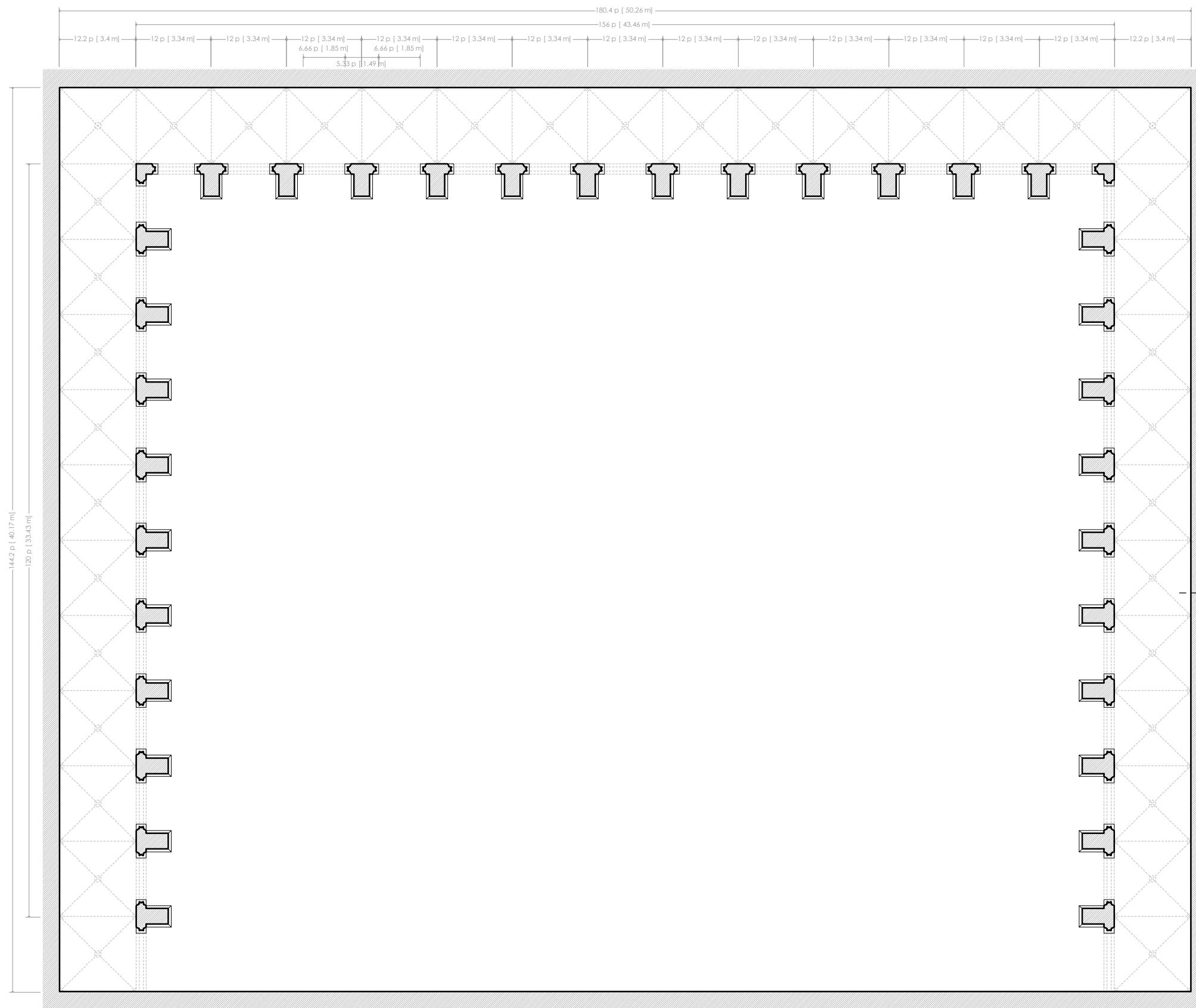

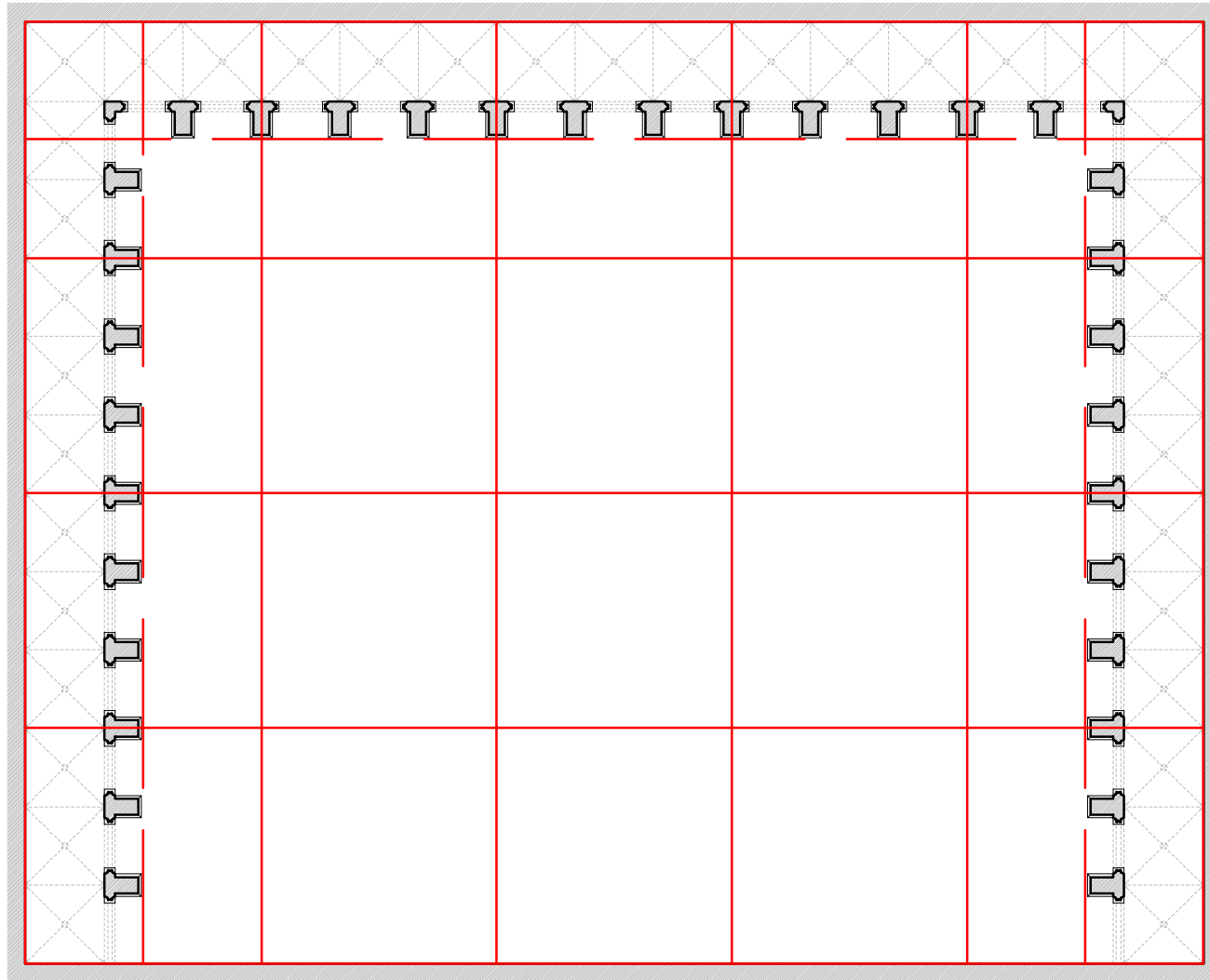

PLANTA BAJA CONSTRUIDA

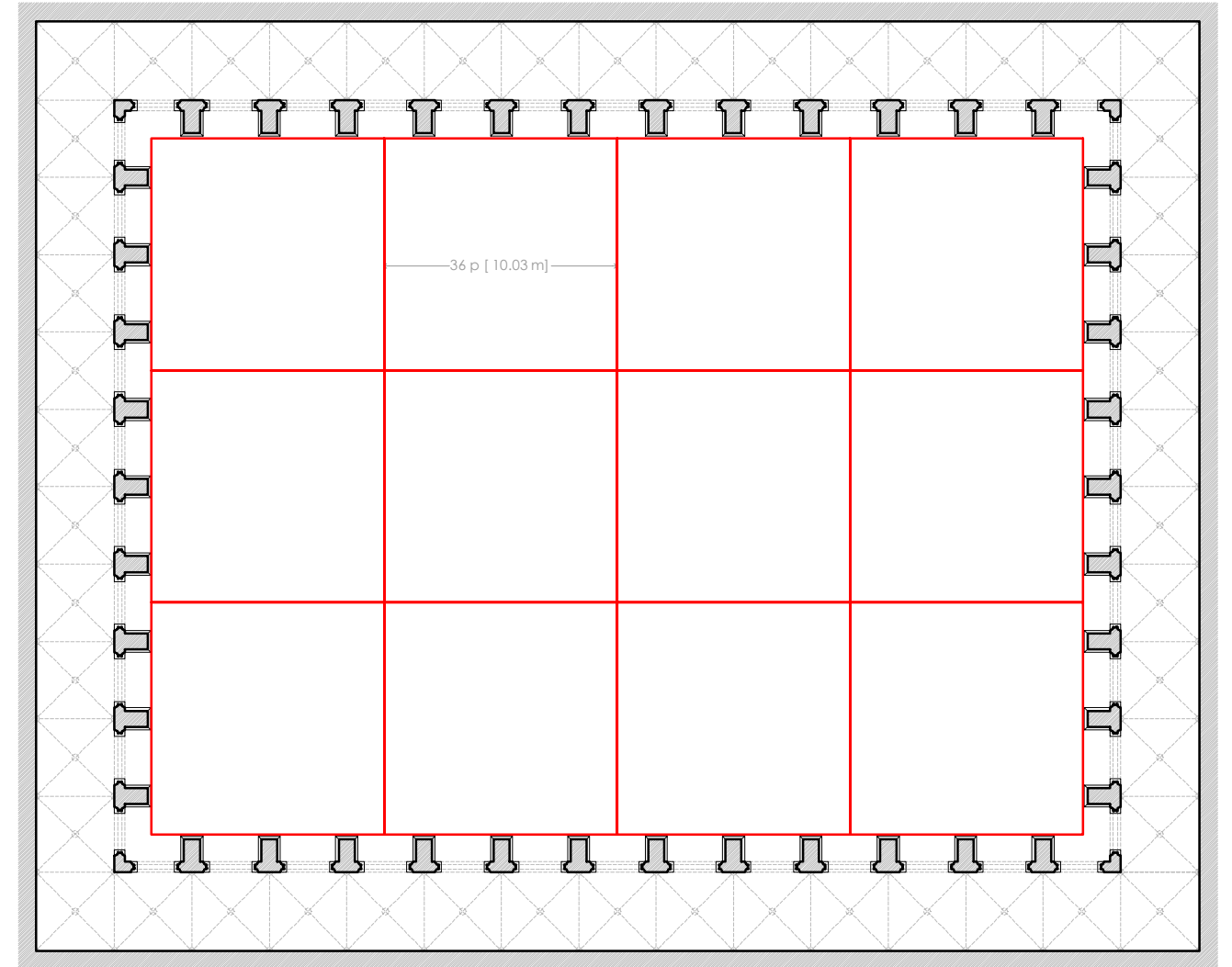

PLANTA BAJA PROYECTO





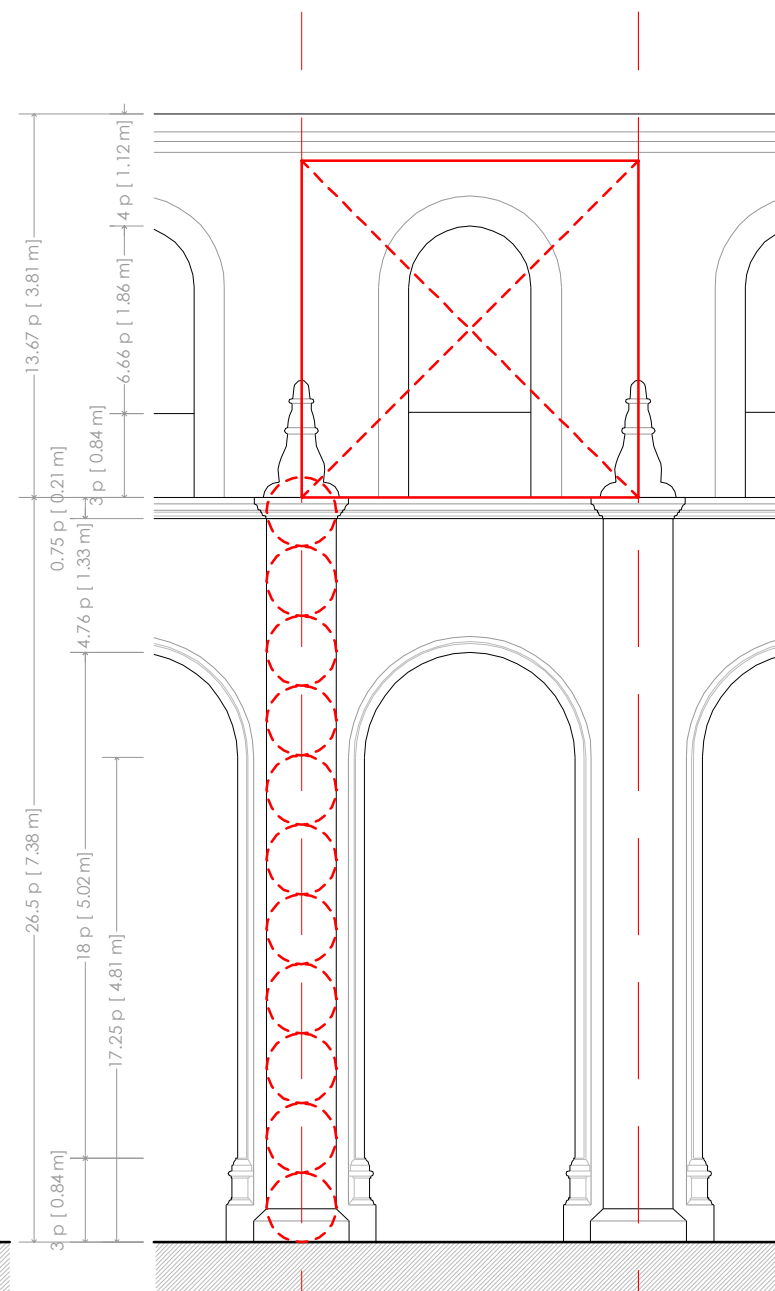
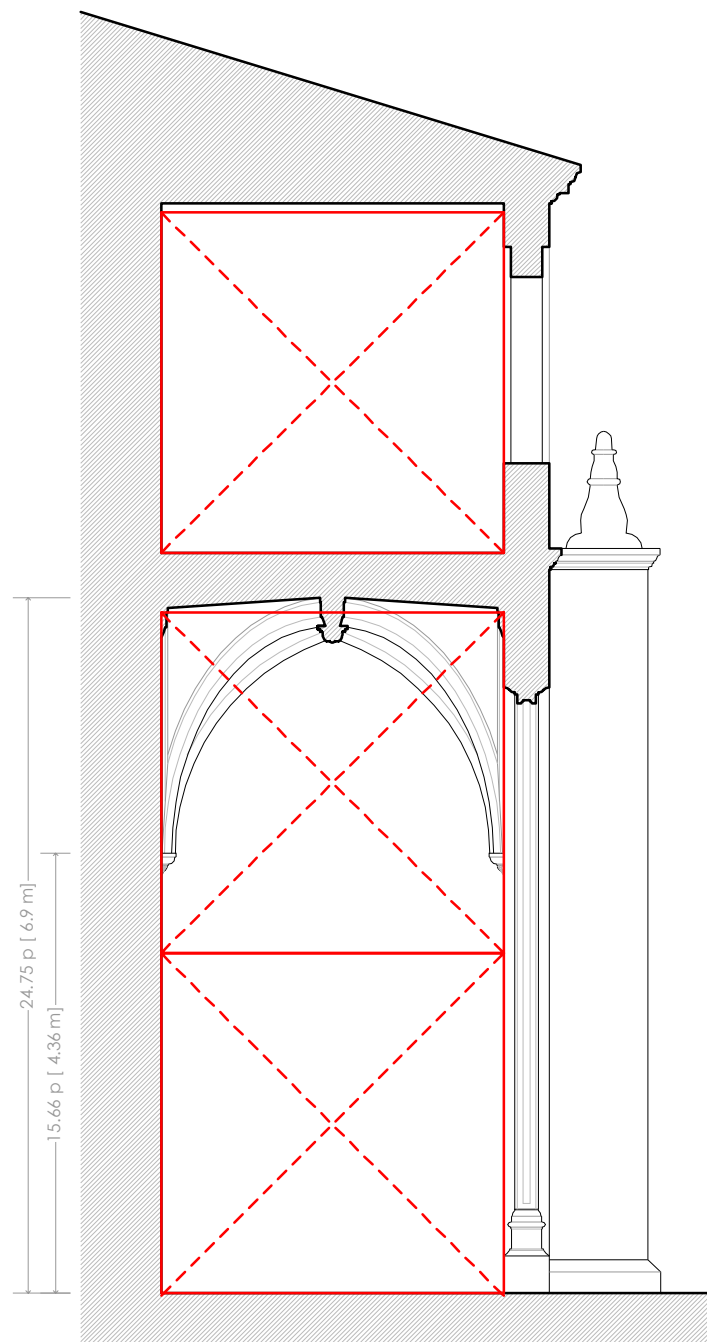
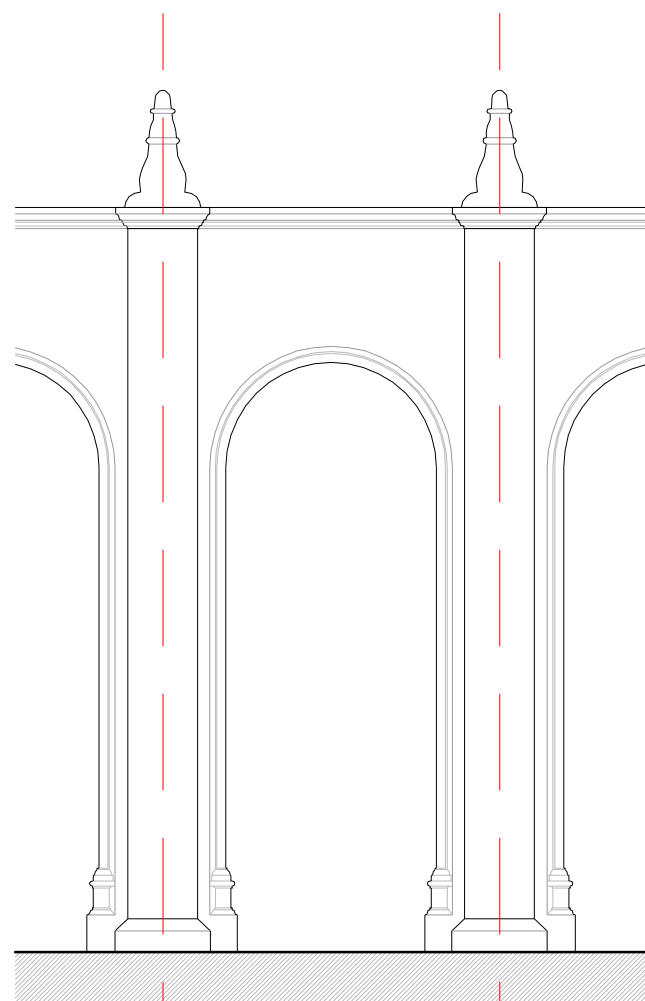
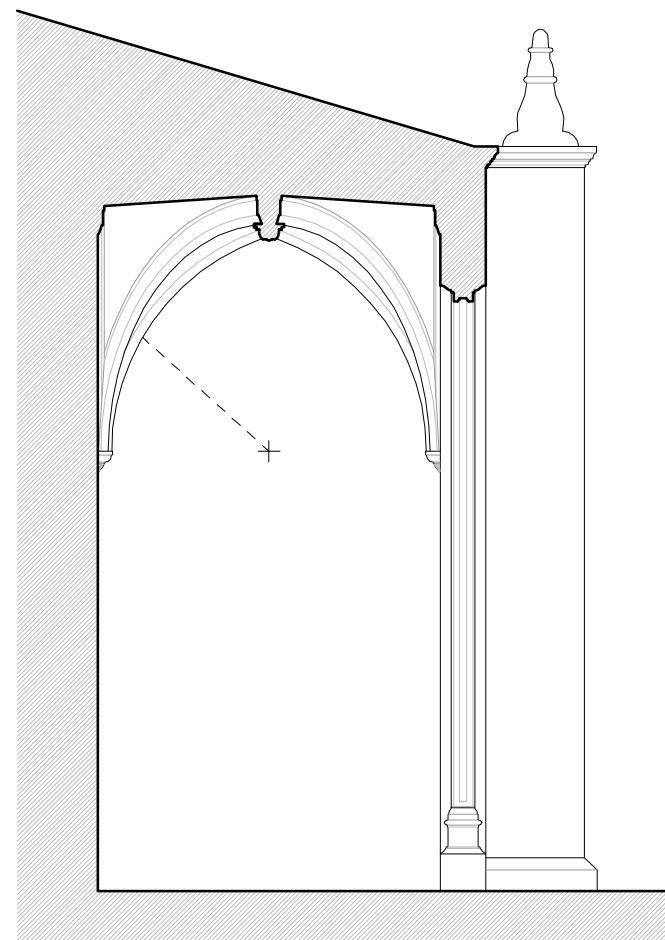

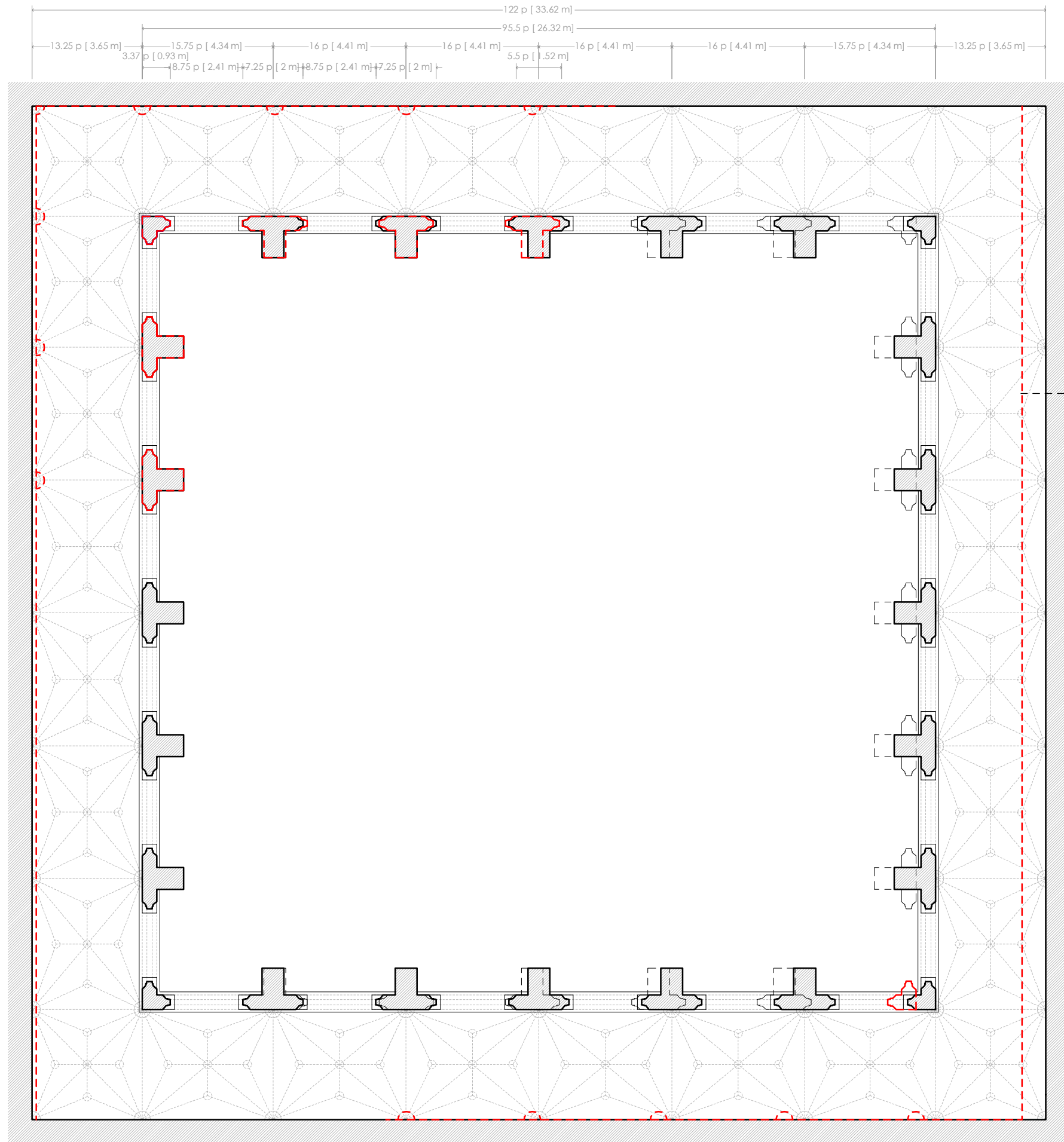

DETALLE CURVATURA ARCOS e:1/75

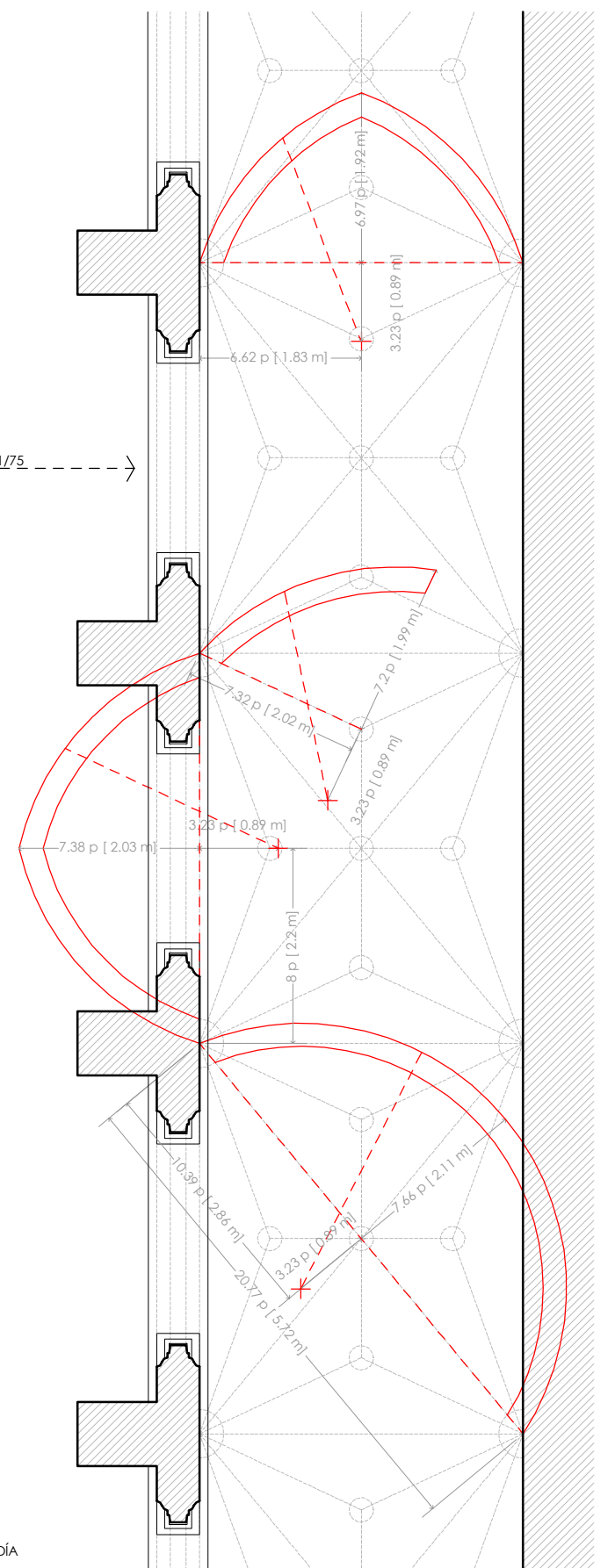

- CLAUSTRO PROYECTO
- CLAUSTRO CONSTRUIDO
- CLAUSTRO EXISTENTE HOY EN DÍA

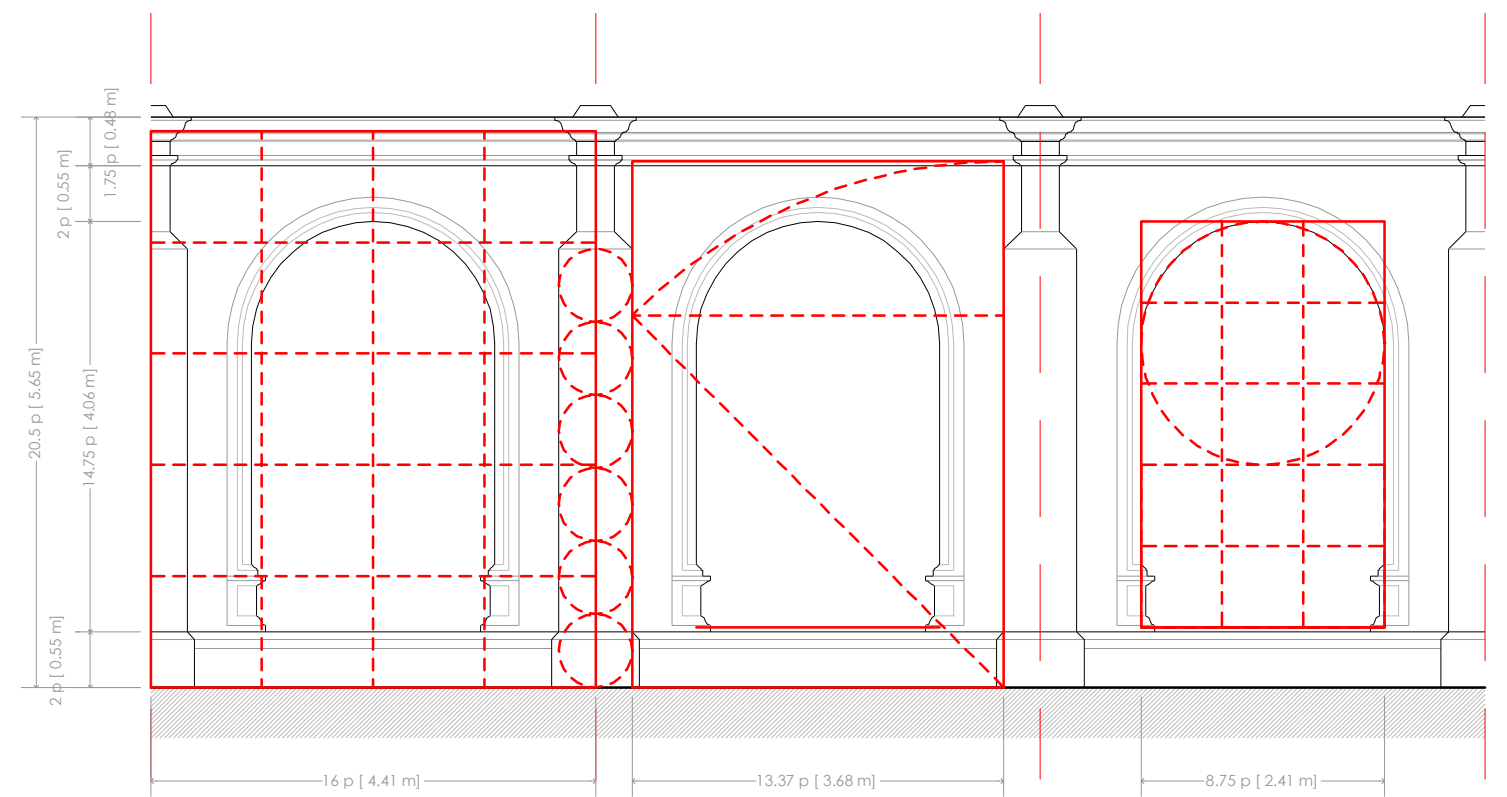
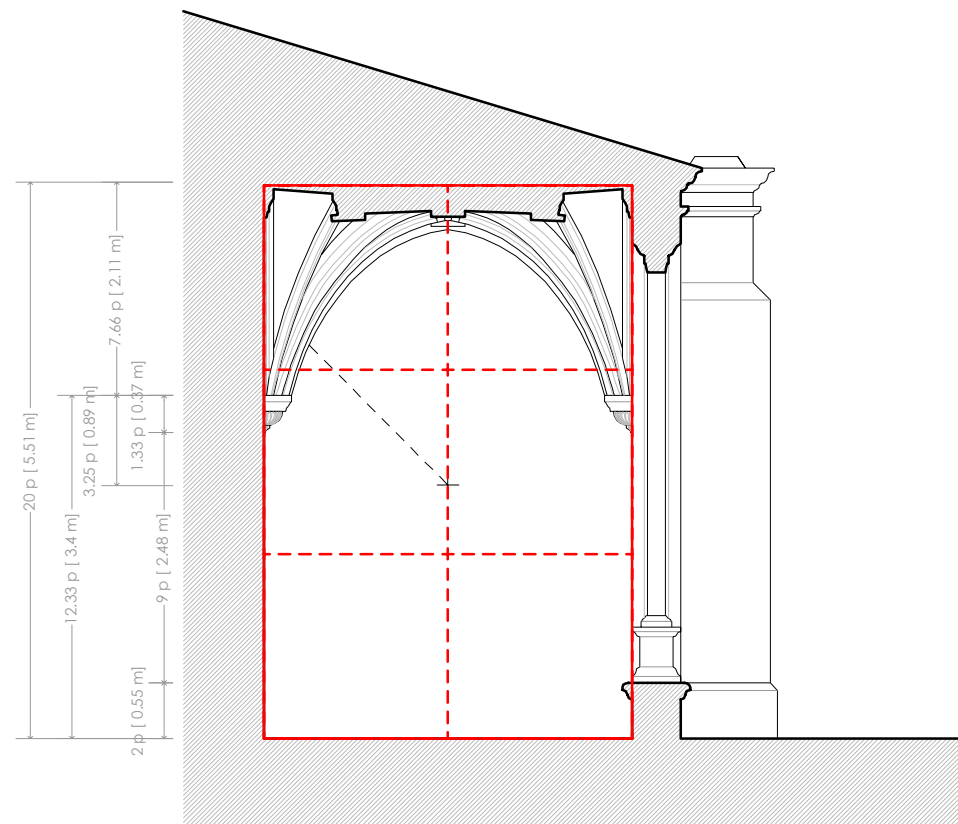



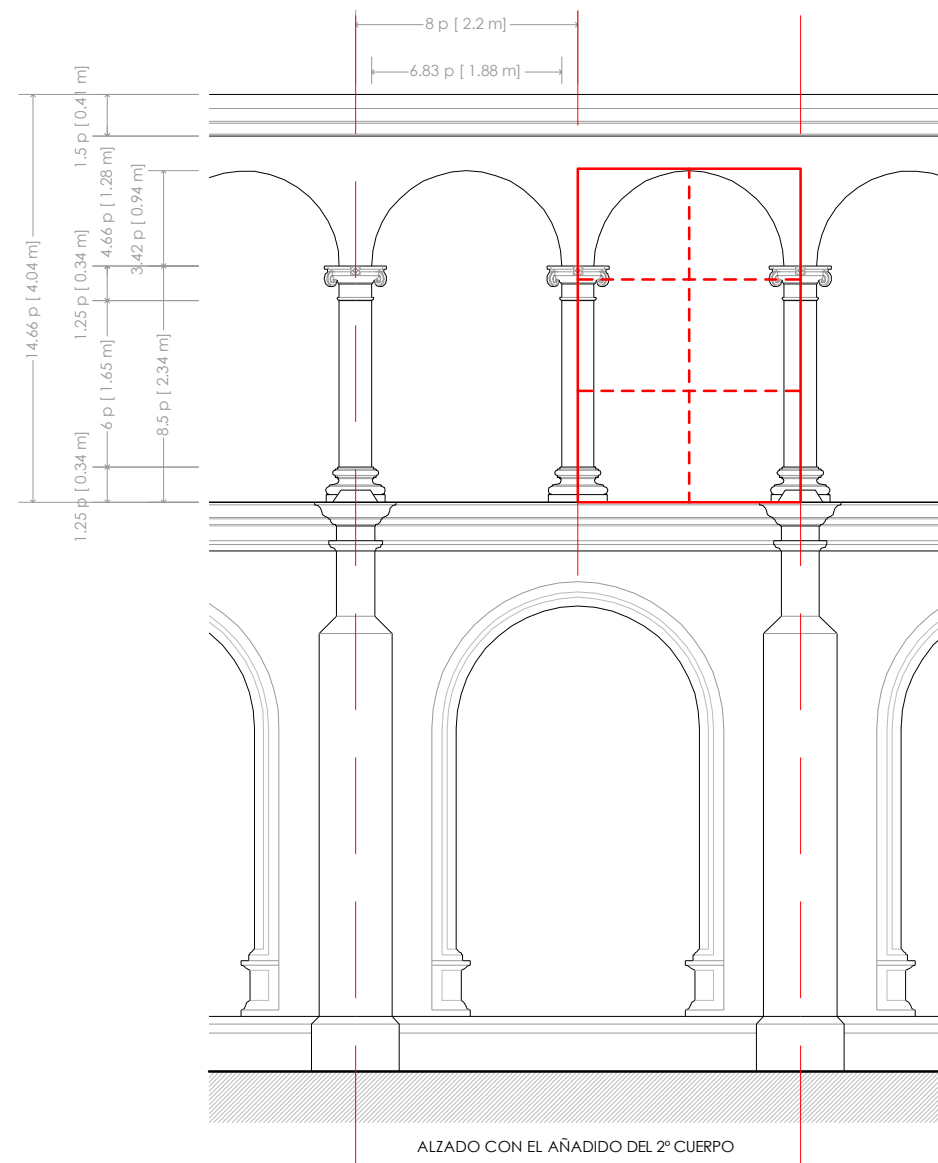

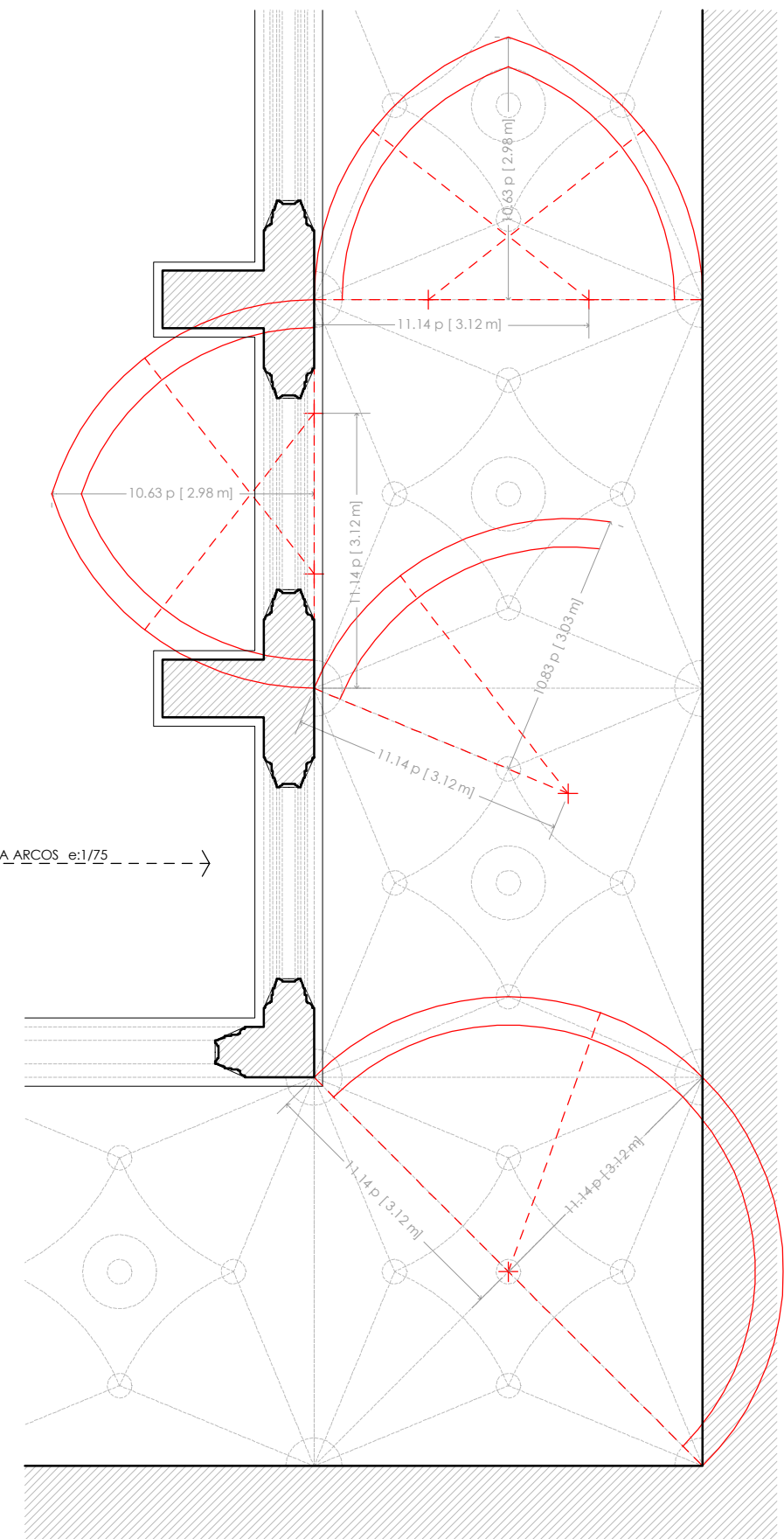
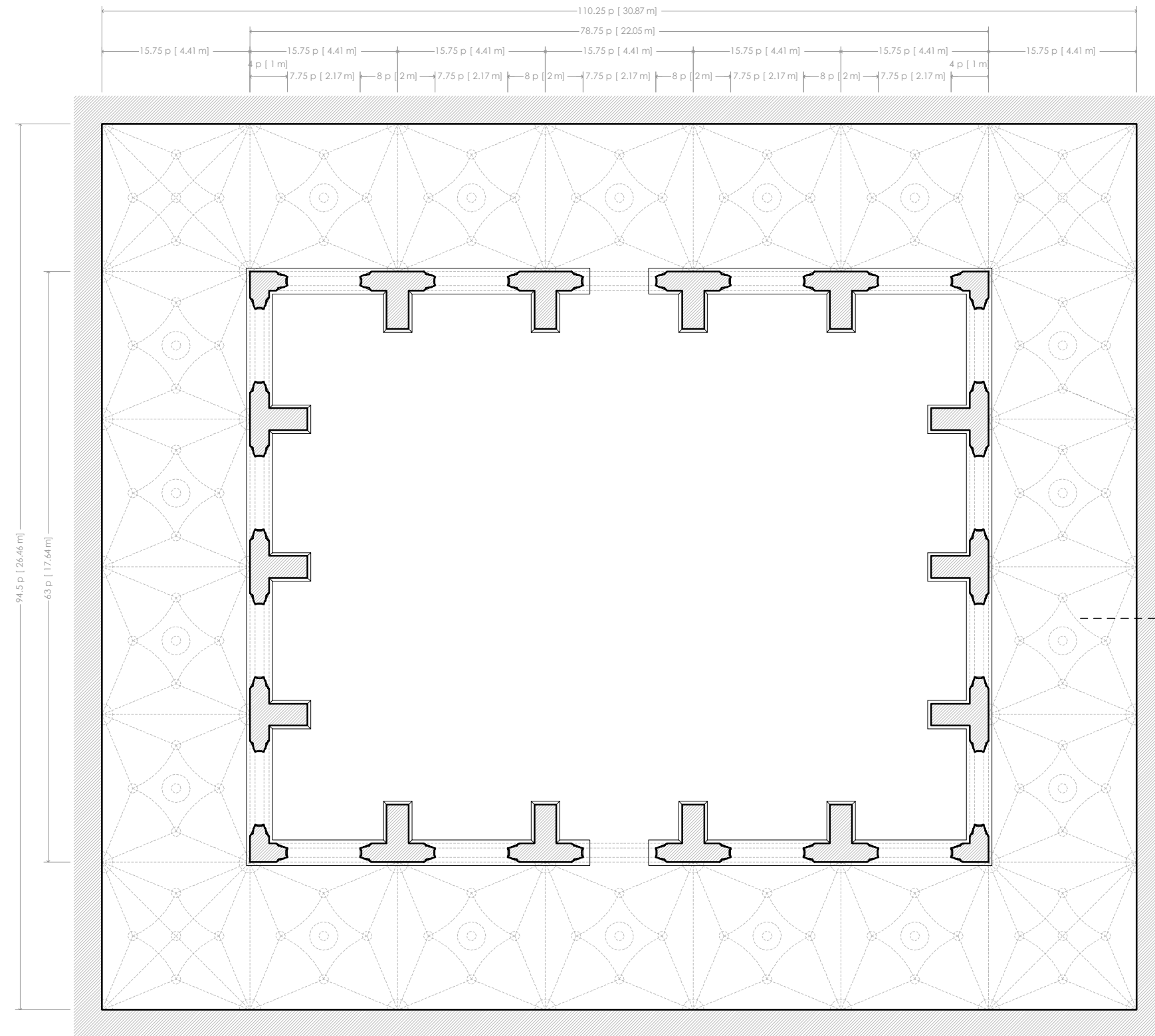

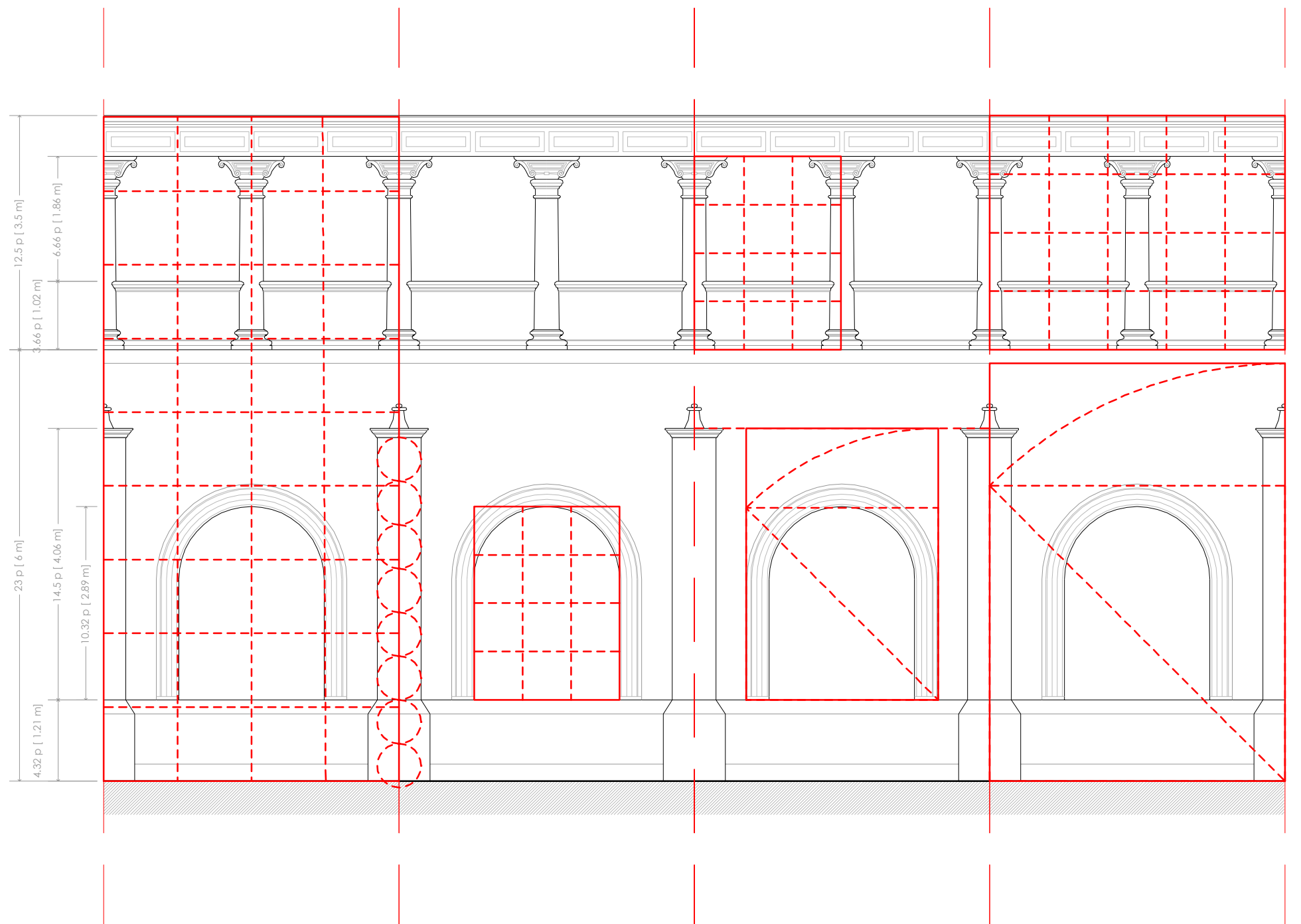
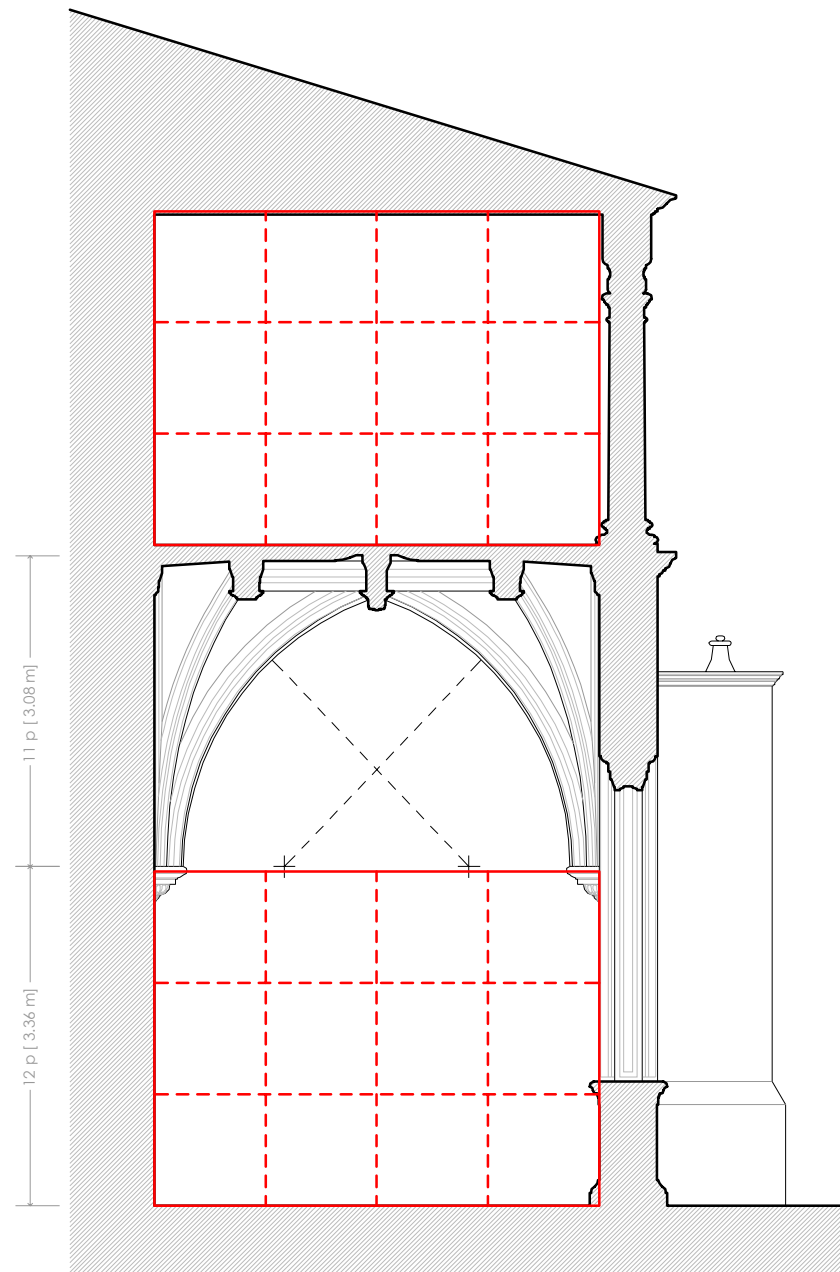

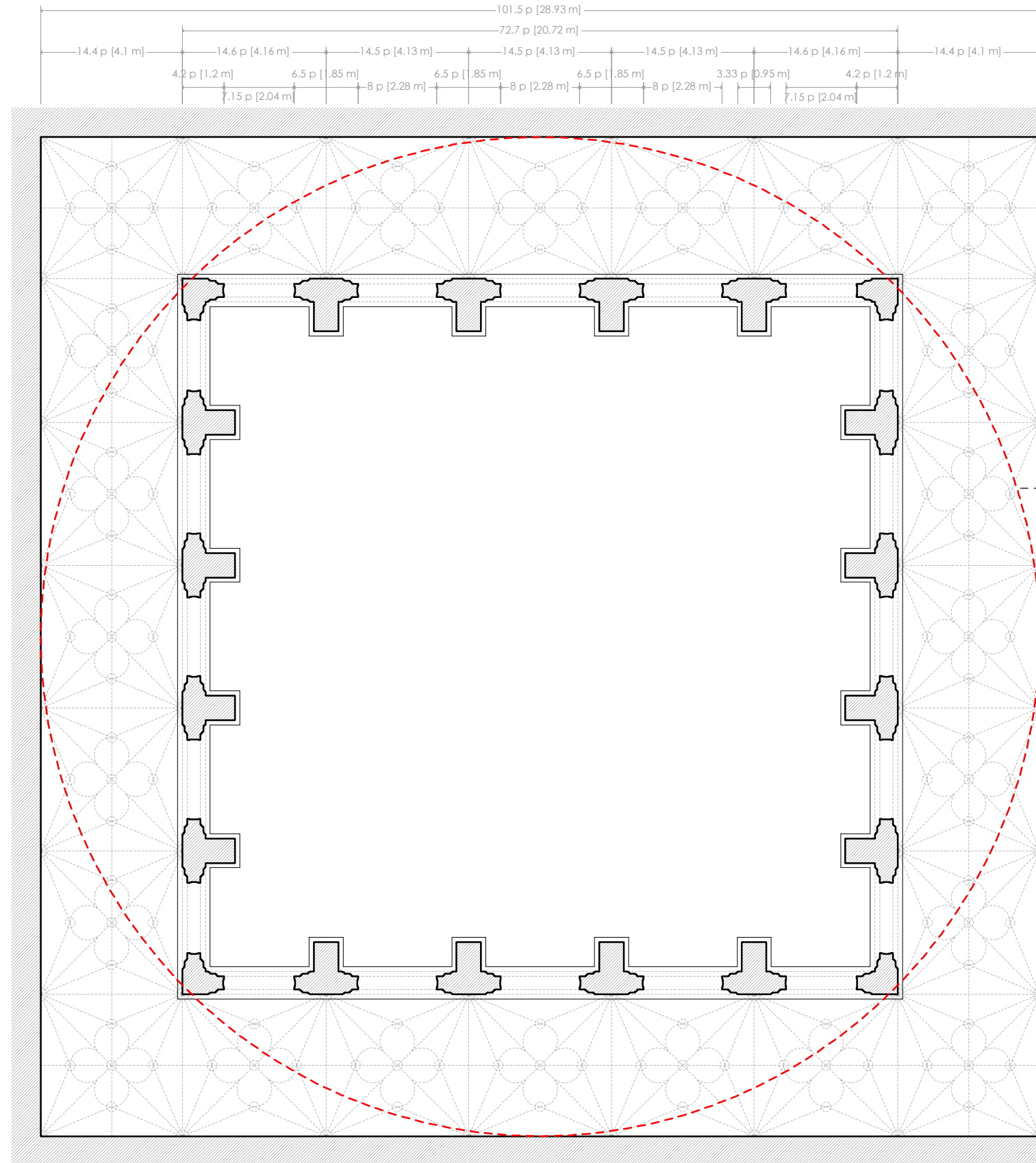

DETALLE CURVATURA ARCOS e:1/75

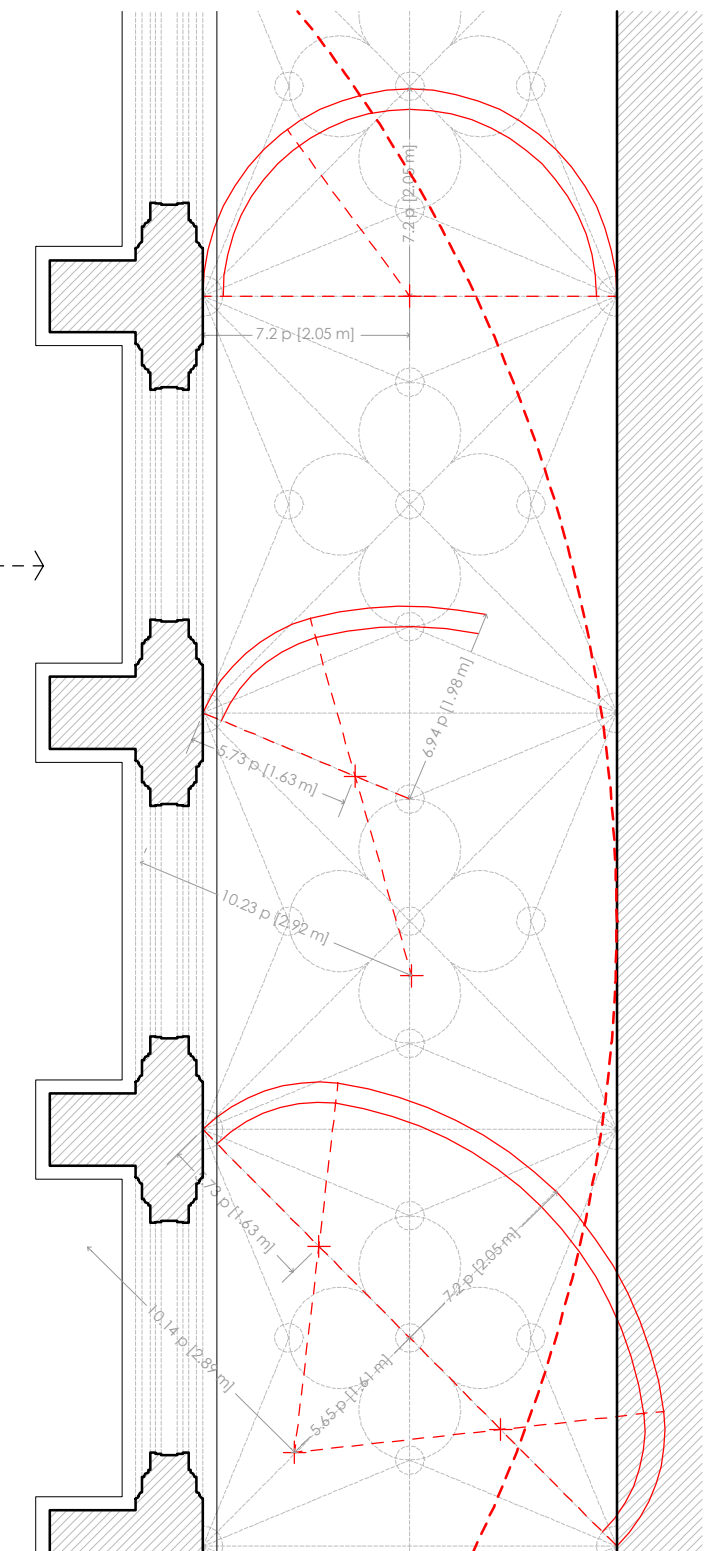

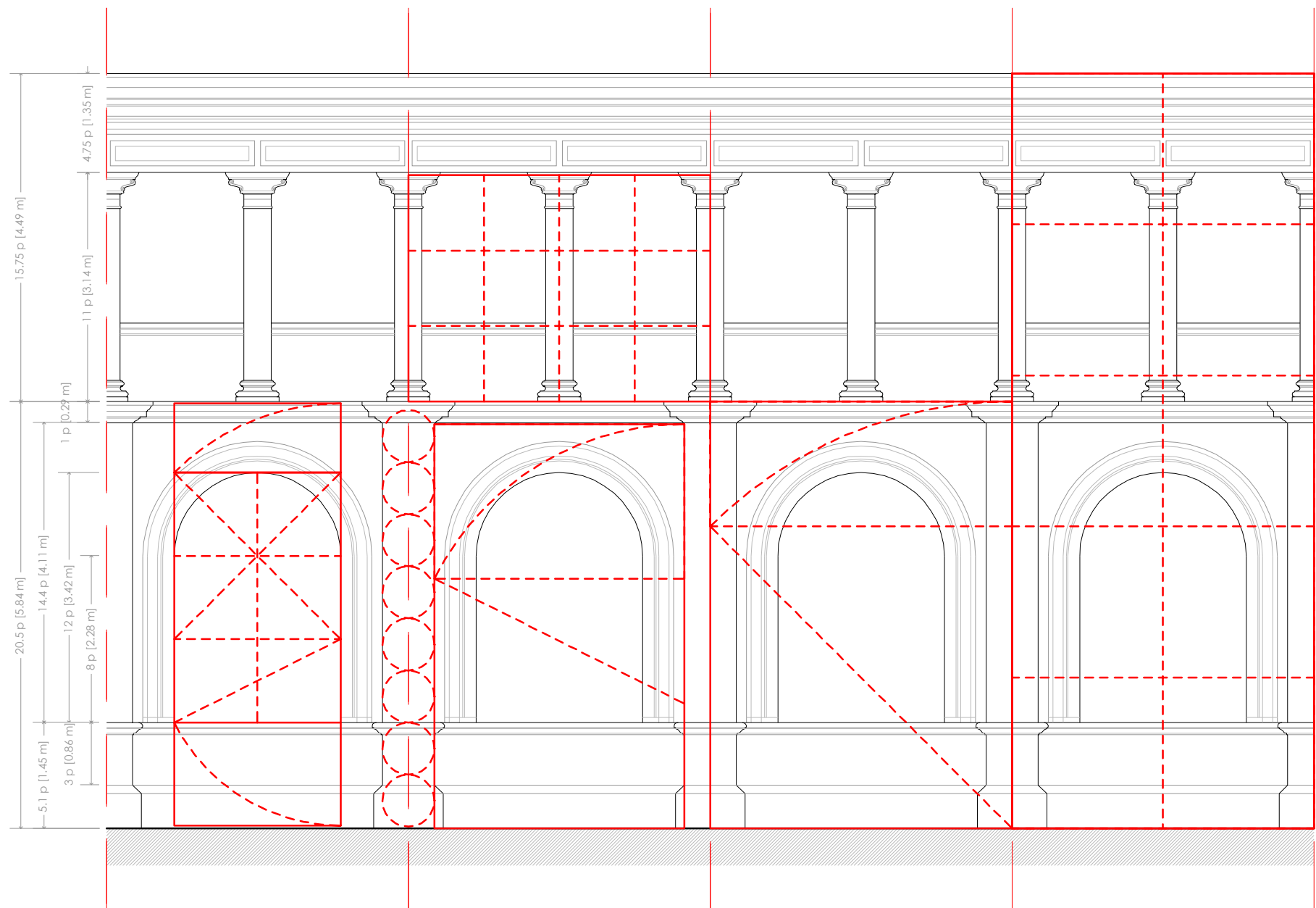
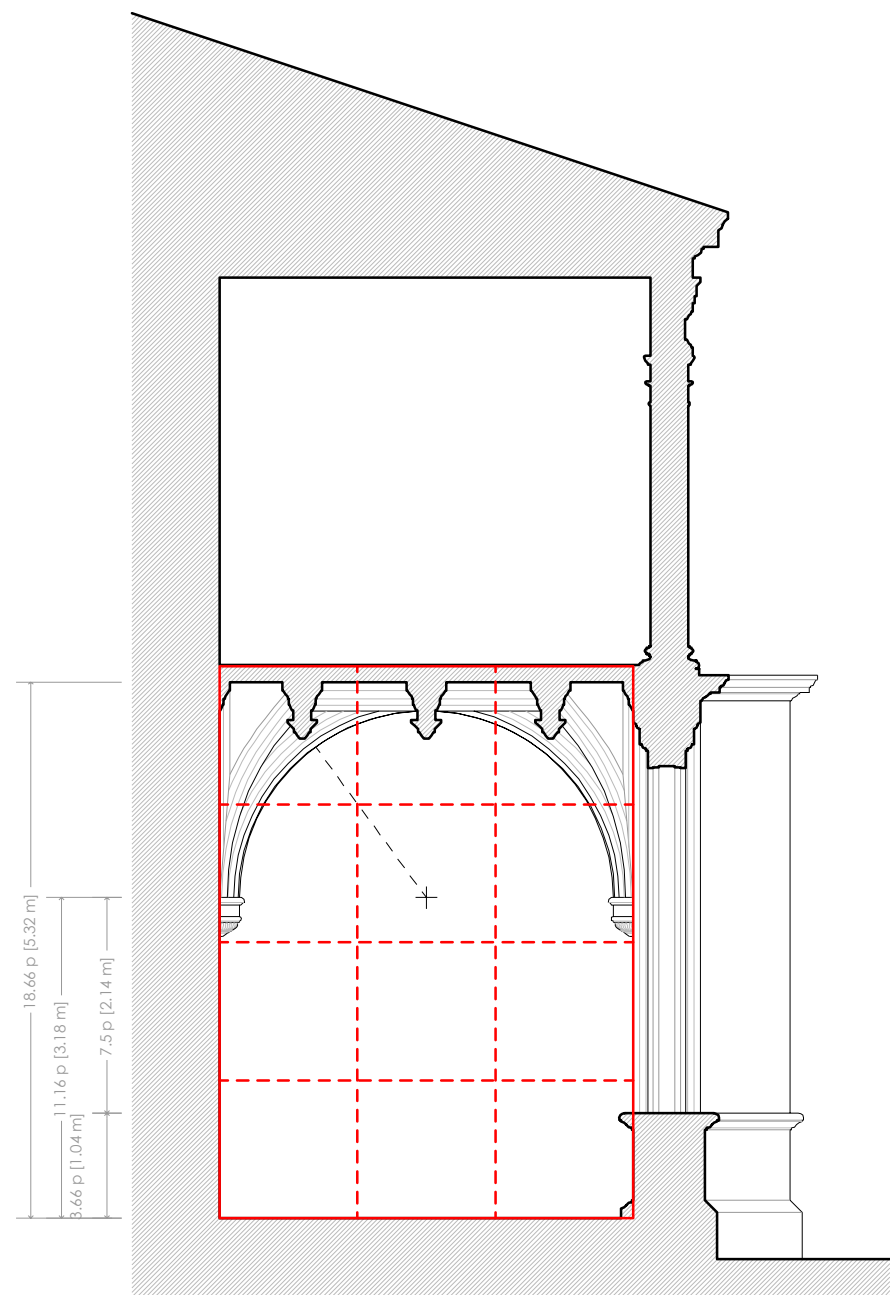



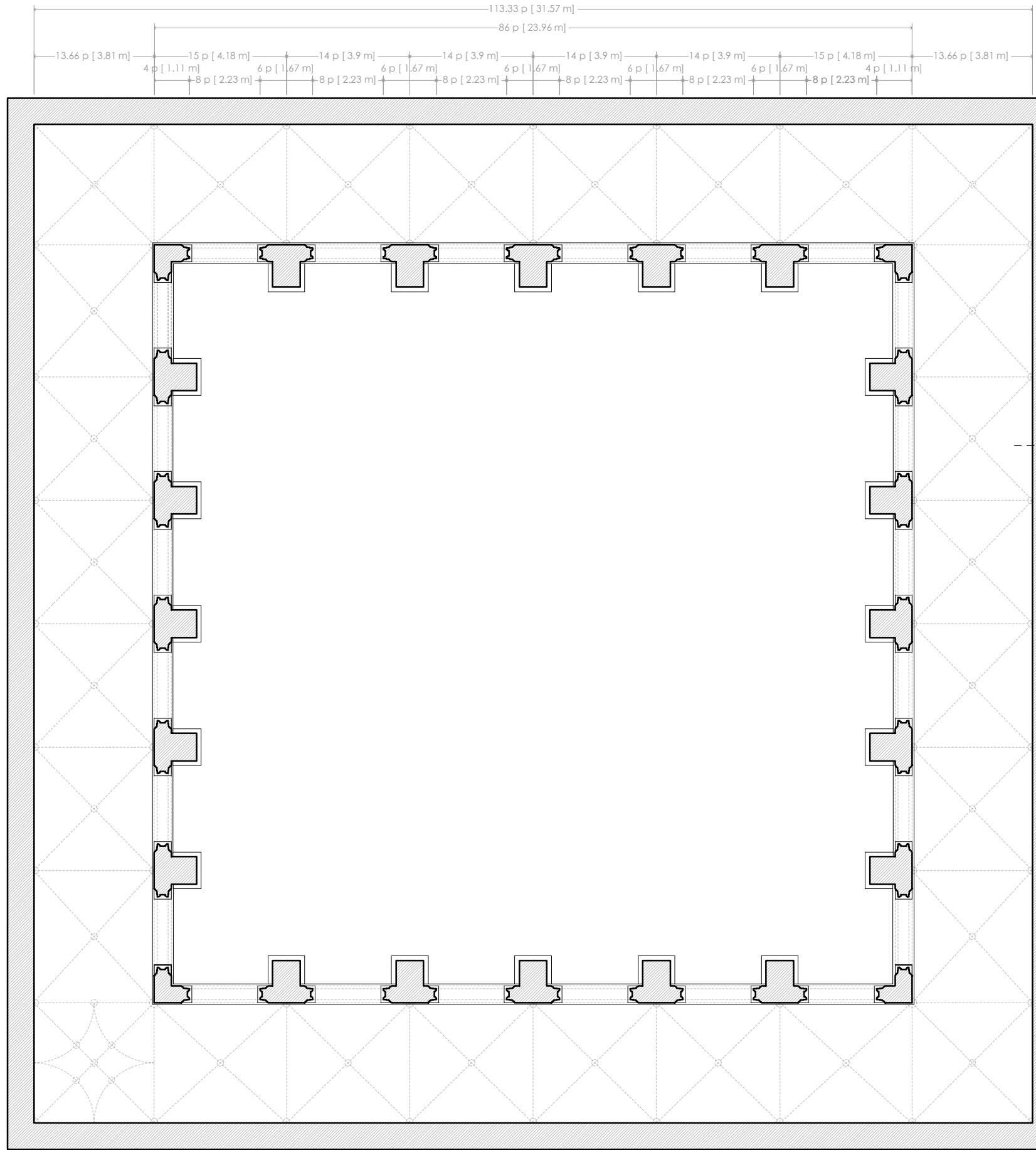

DETALLE CURVATURA ARCOS e:1/75

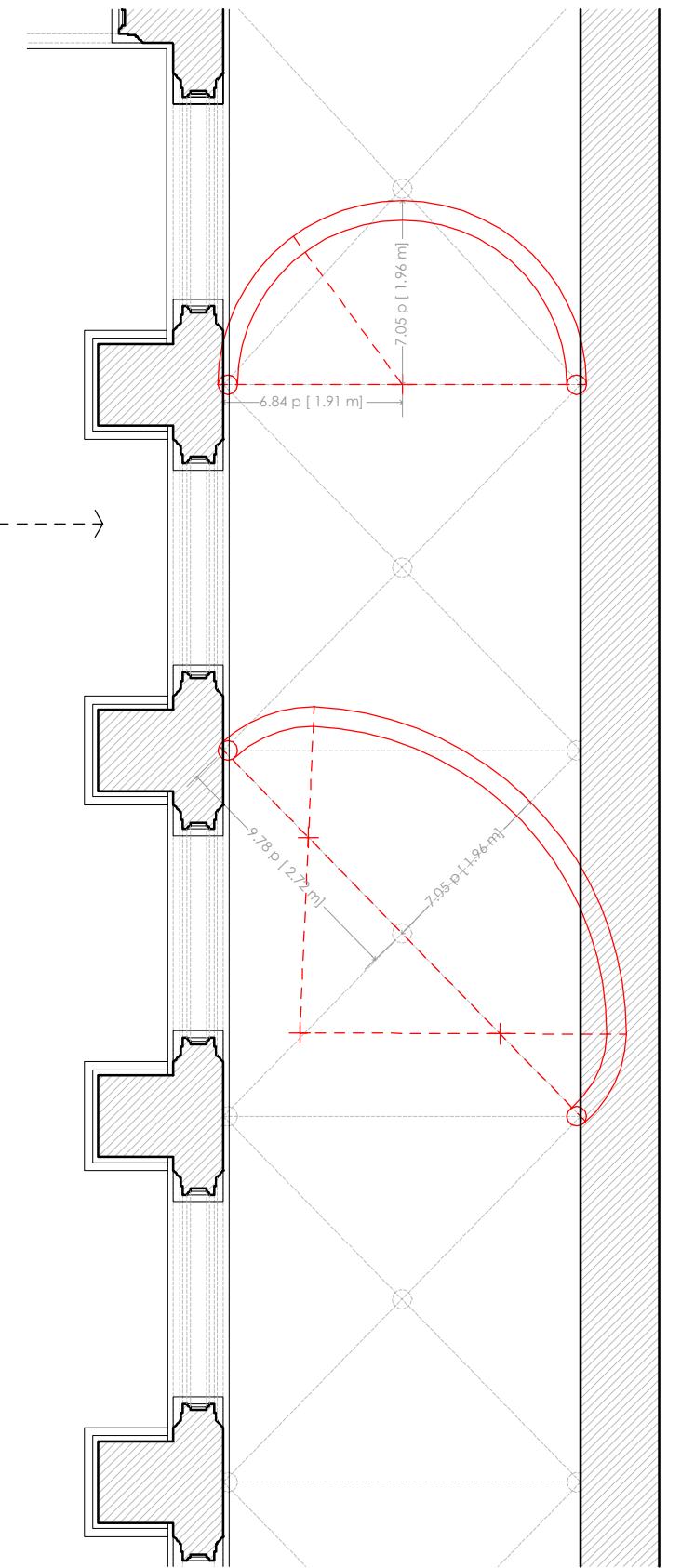

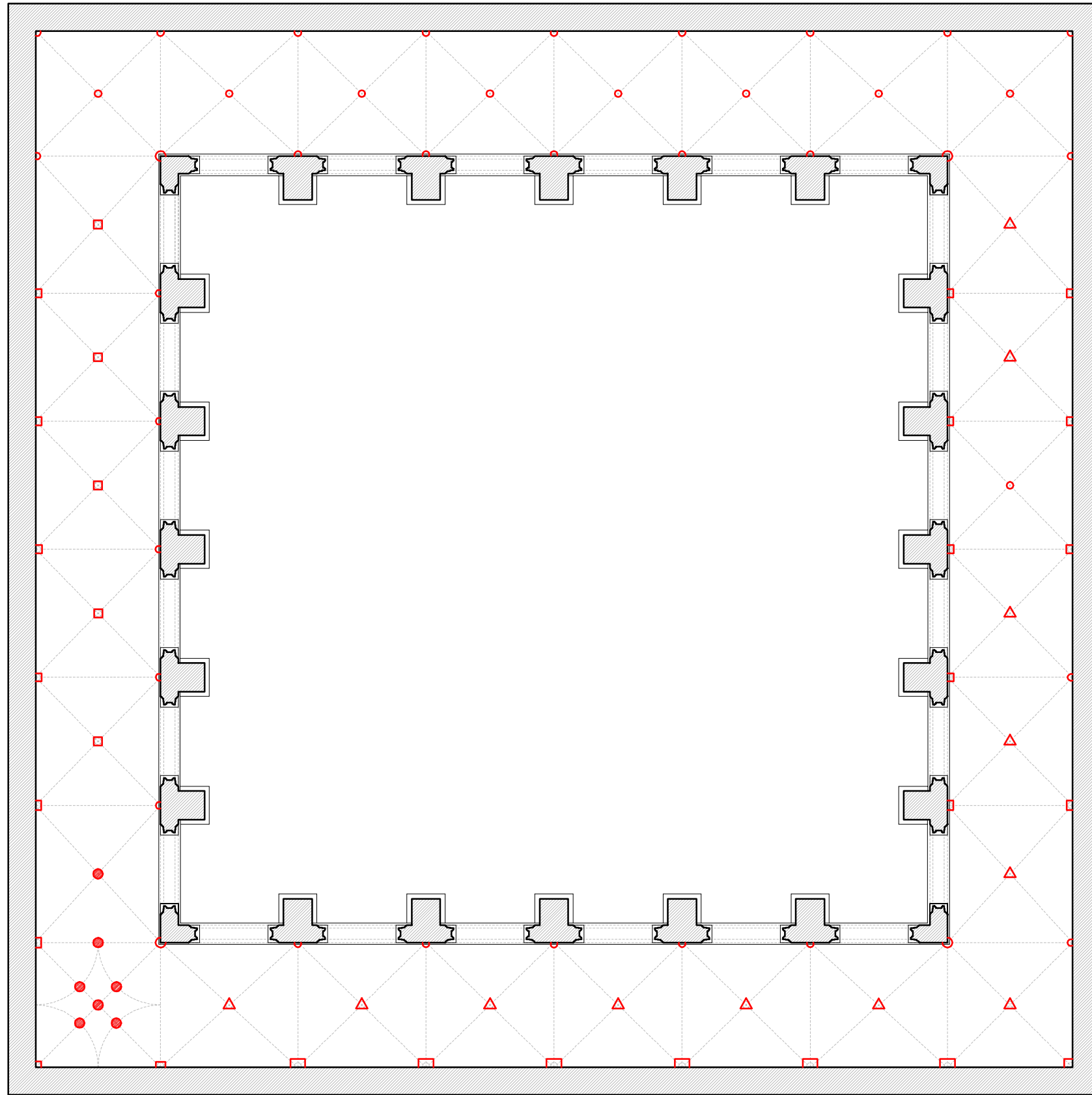

CLAVES

- con forma semicircular.
- colgantes decoradas con motivos vegetales
- colgantes decoradas con pijantes.
- △ con forma de medallón.

MÉNSULAS

- entablamento troncocónico con remate inferior en forma de semicírculo
- entablamento troncocónico con remate inferior en forma de cuarto de círculo
- entablamento troncocónico muy resaltado con remate inferior en forma de cuarto de círculo



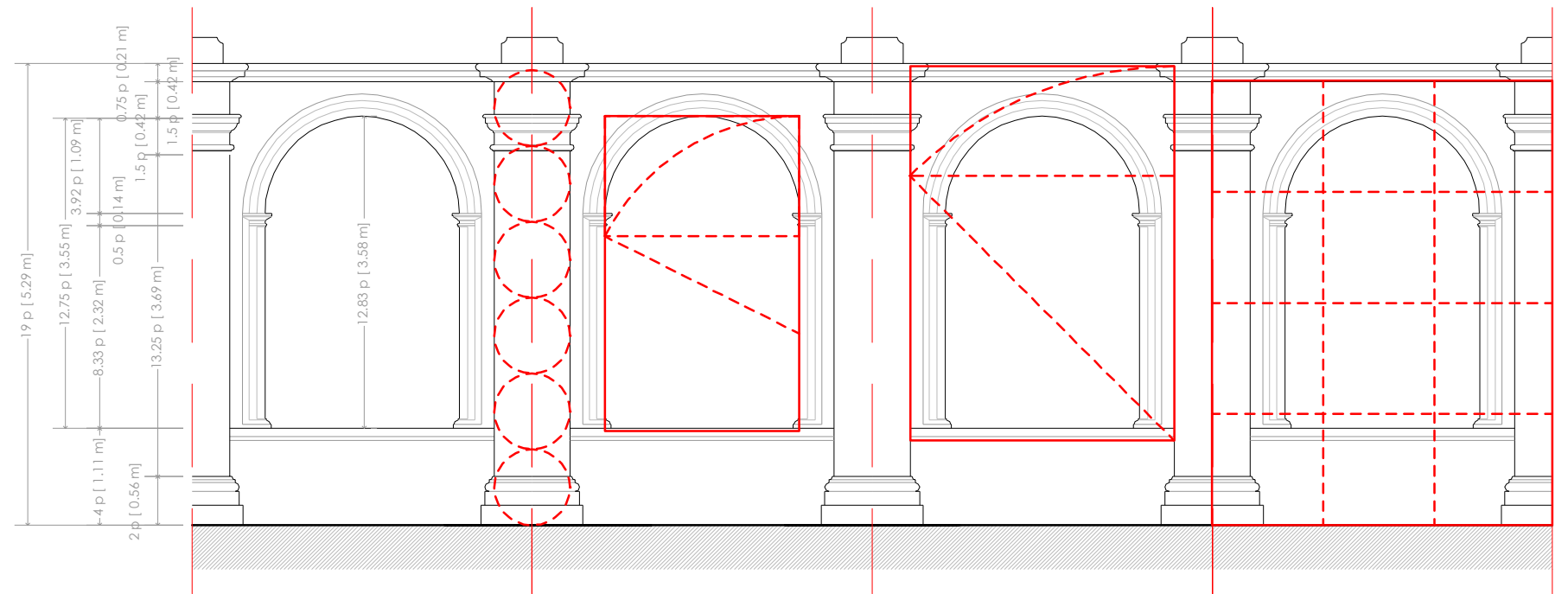
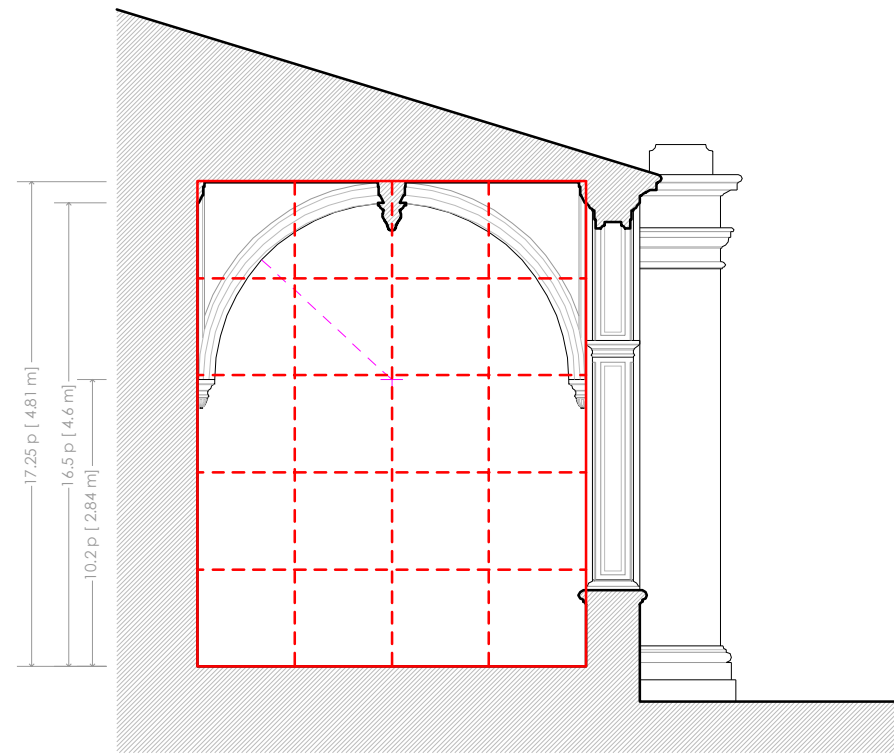

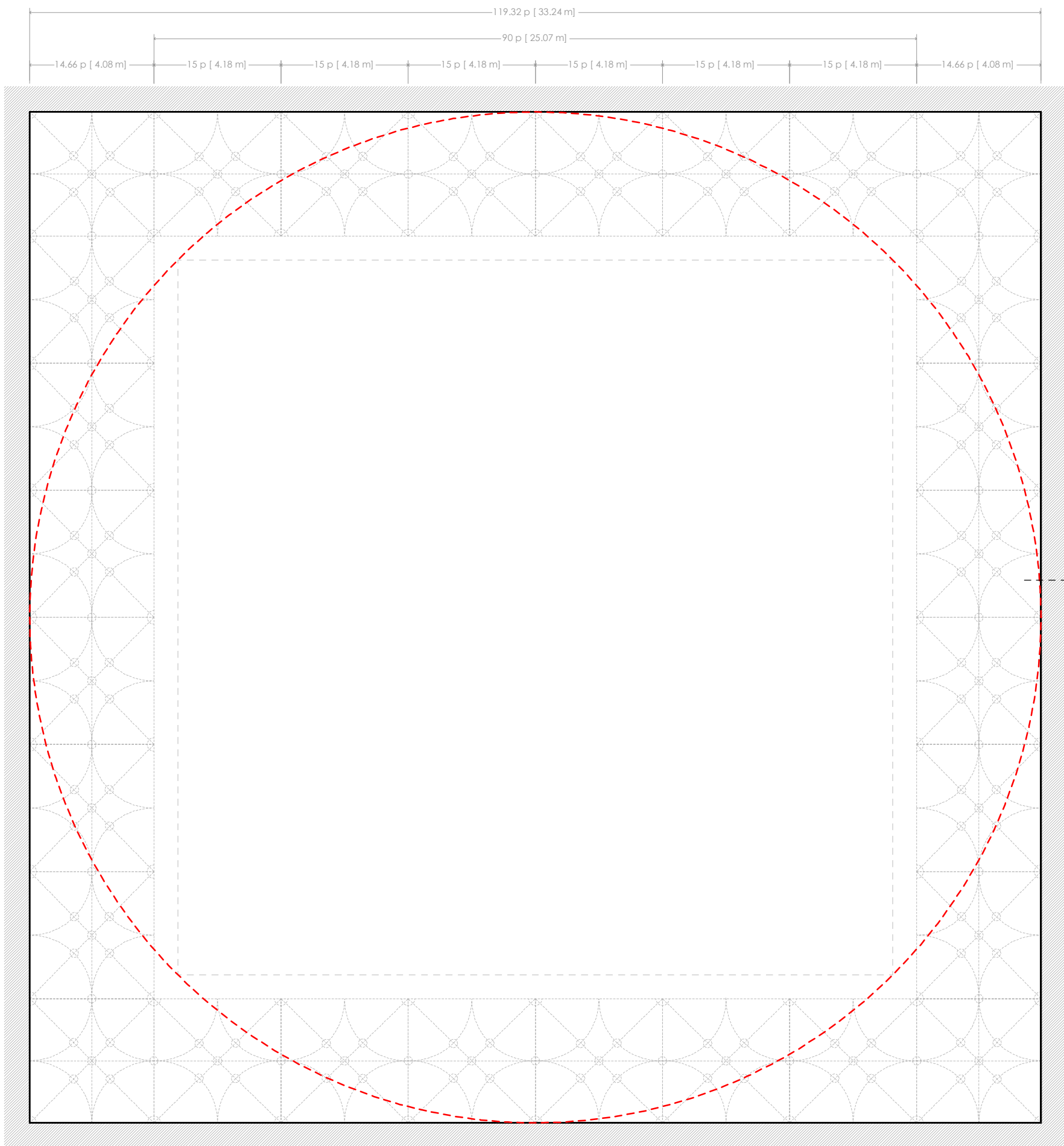

DETALLE CURVATURA ARCOS e:1/75

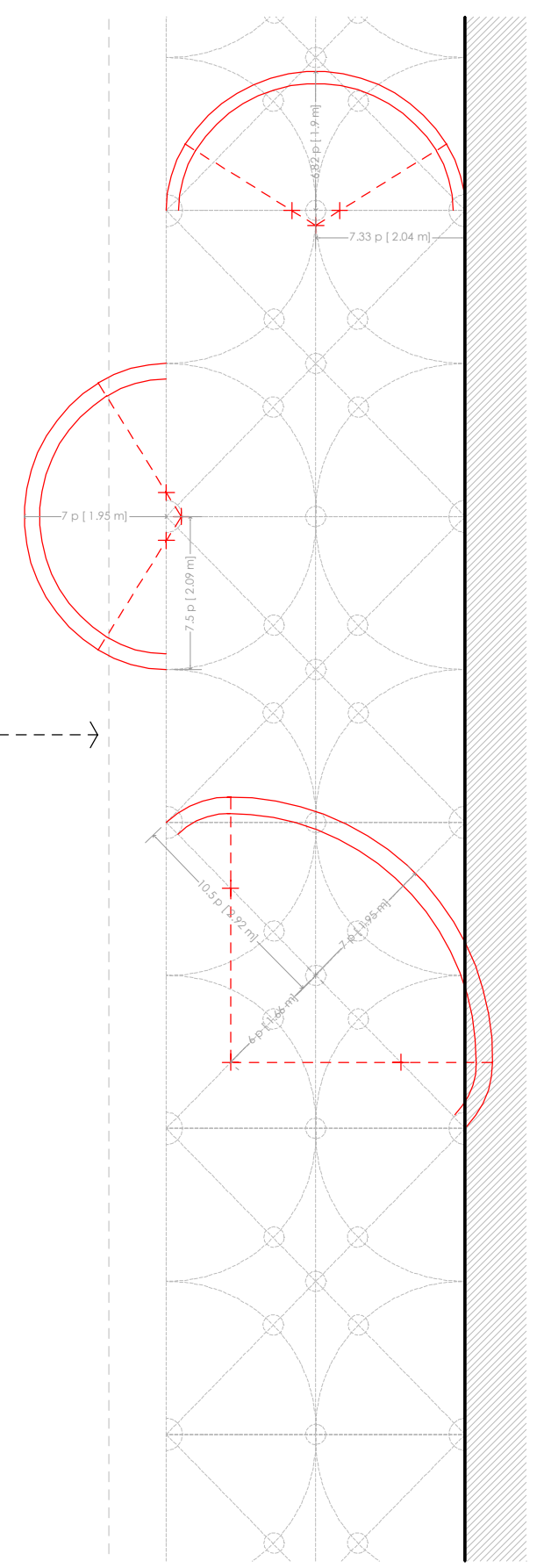

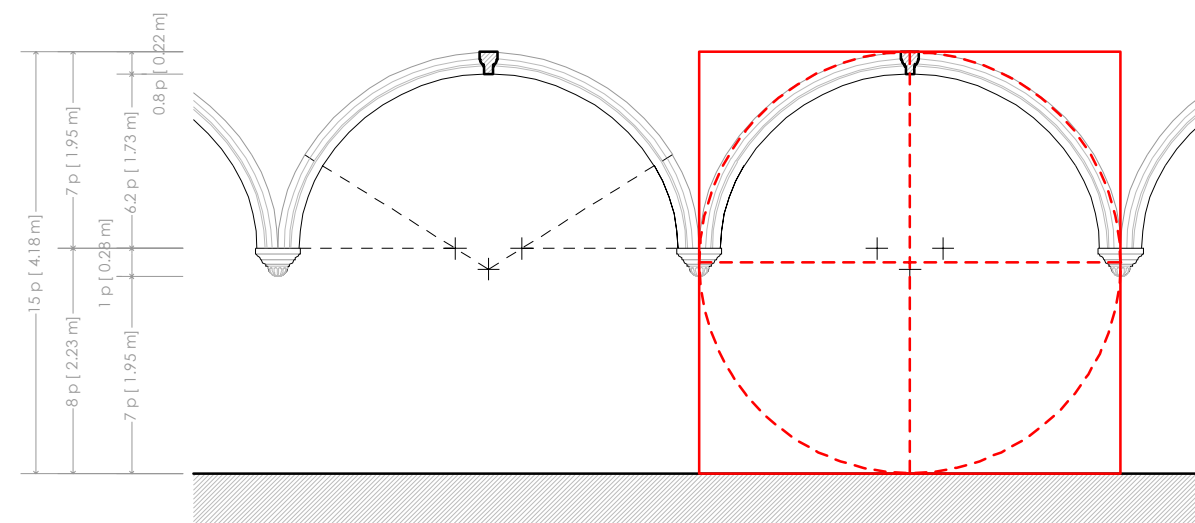
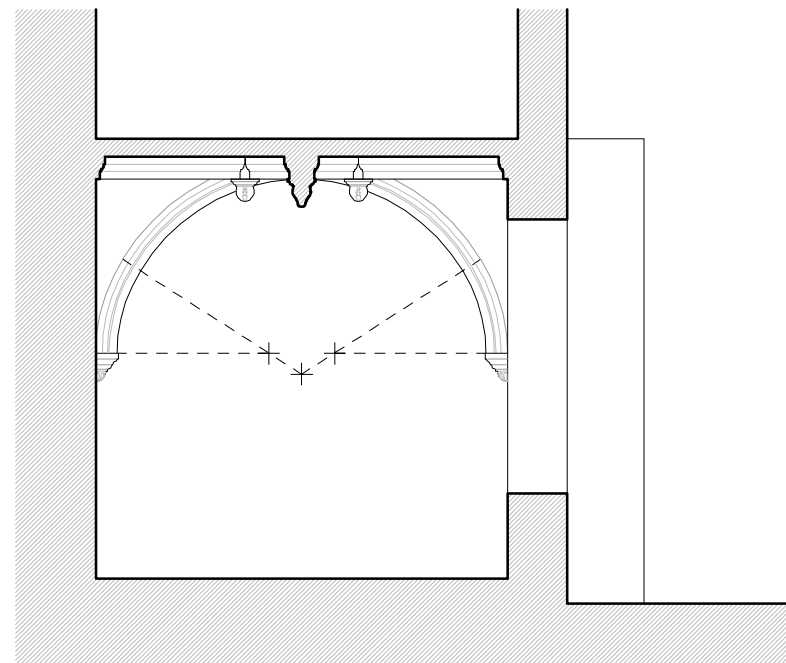



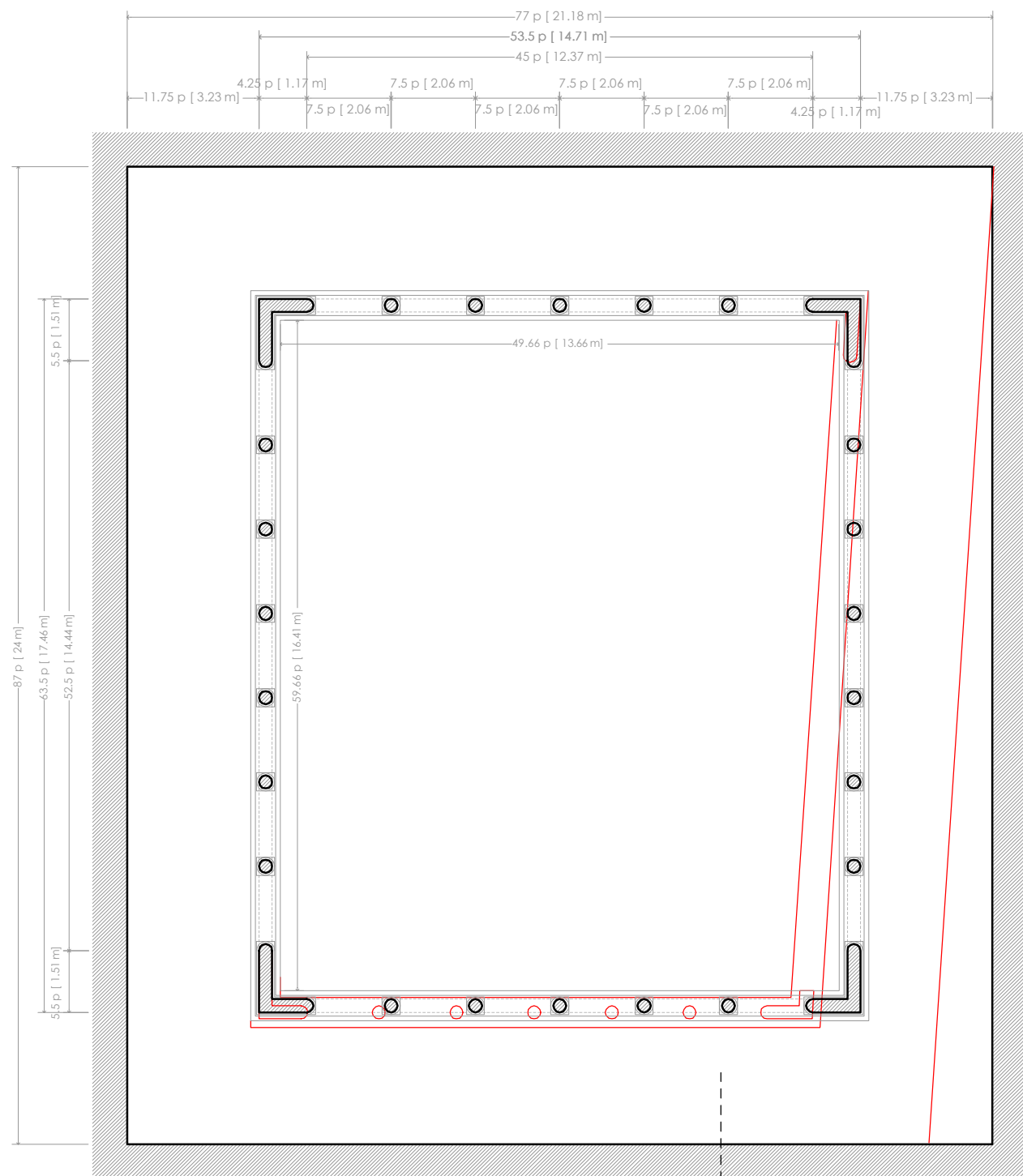

CLAUSTRO EXISTENTE HOY EN DÍA

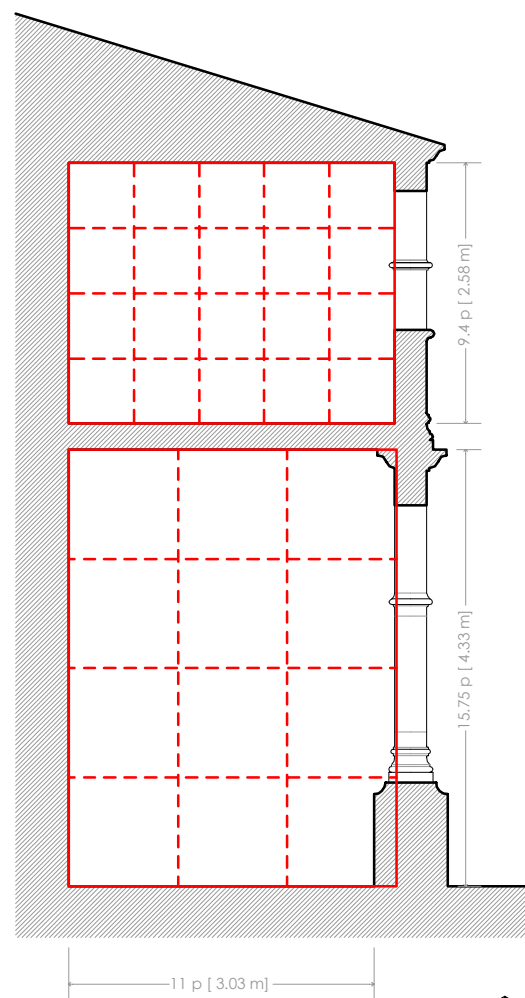

DETALLE ALZADO e:1/75

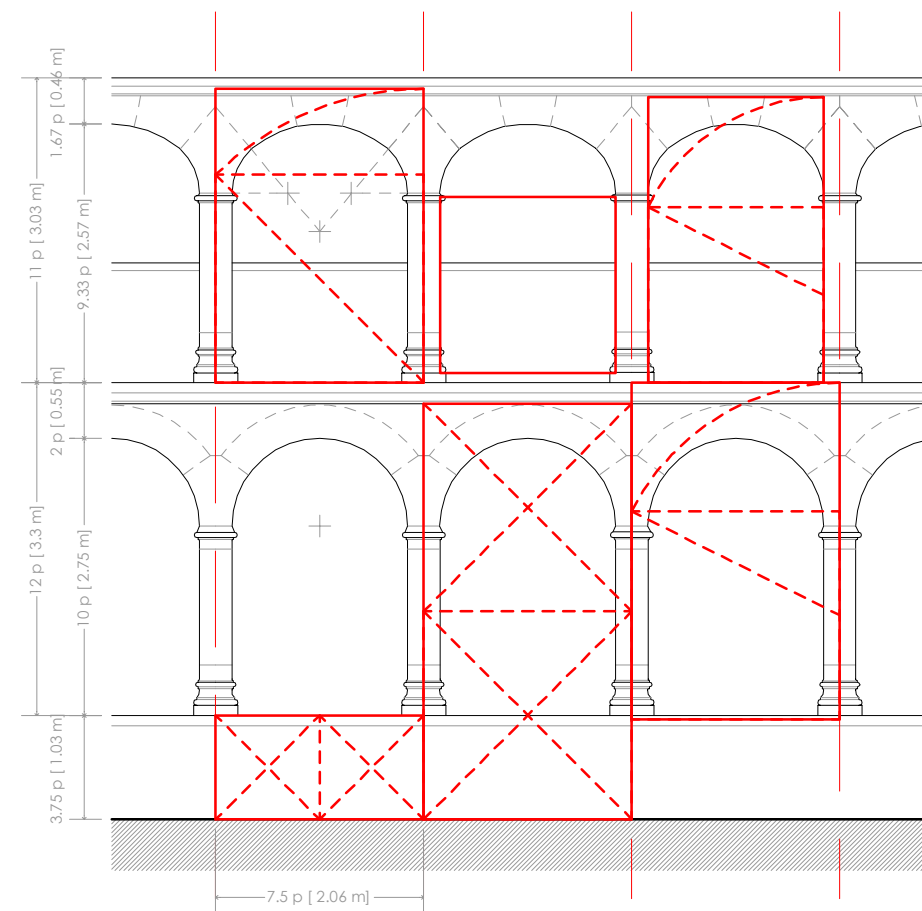

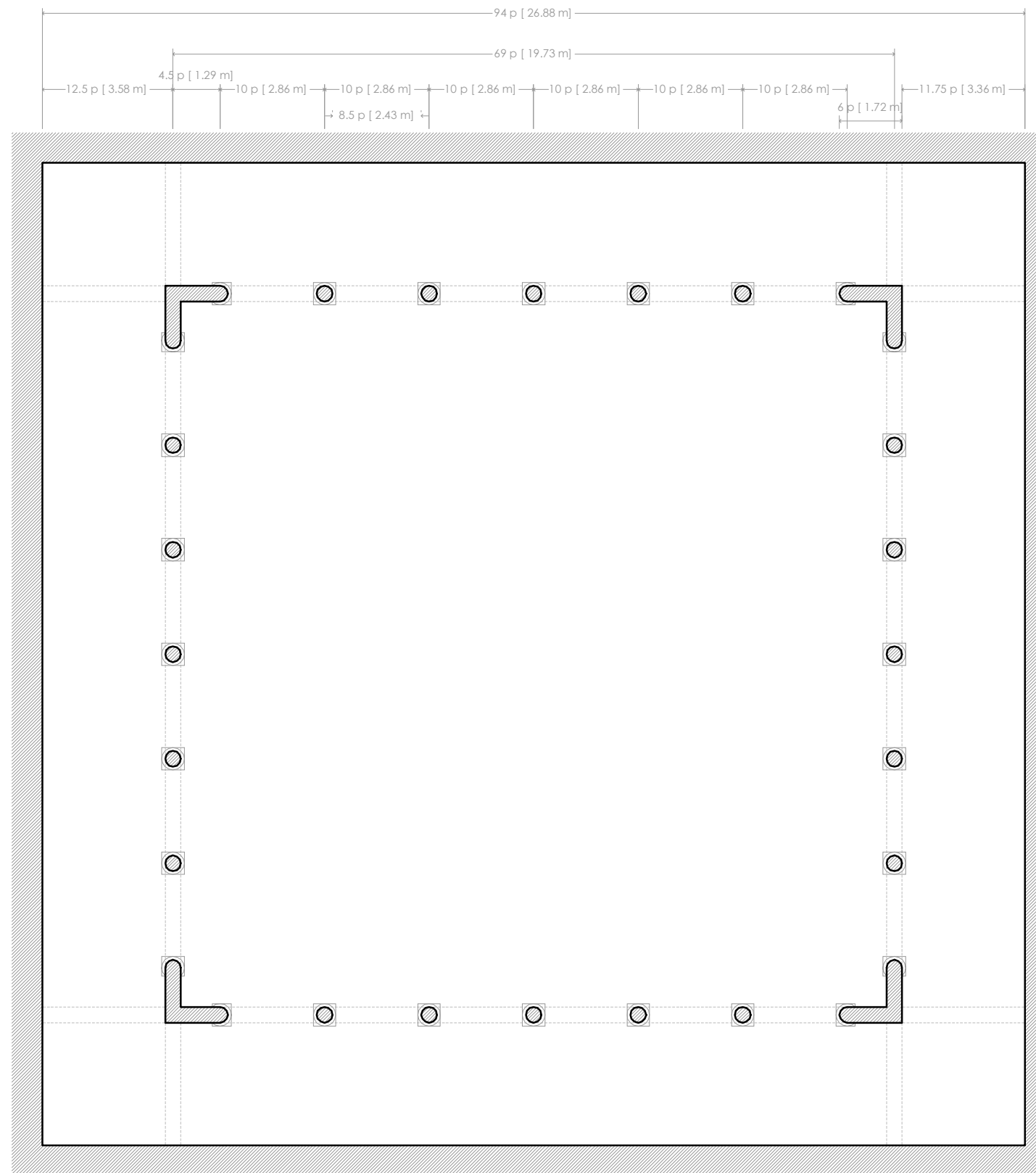

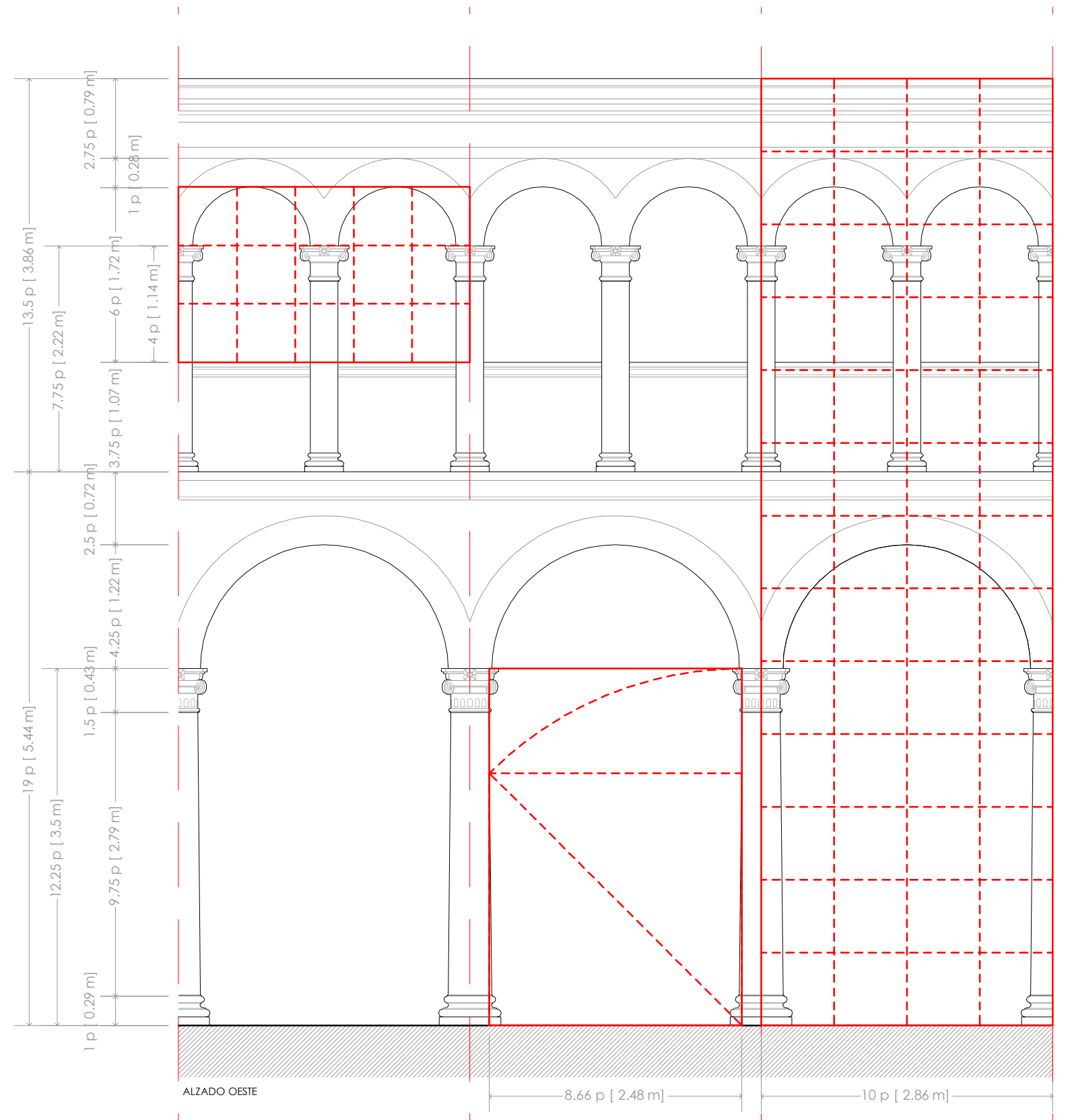
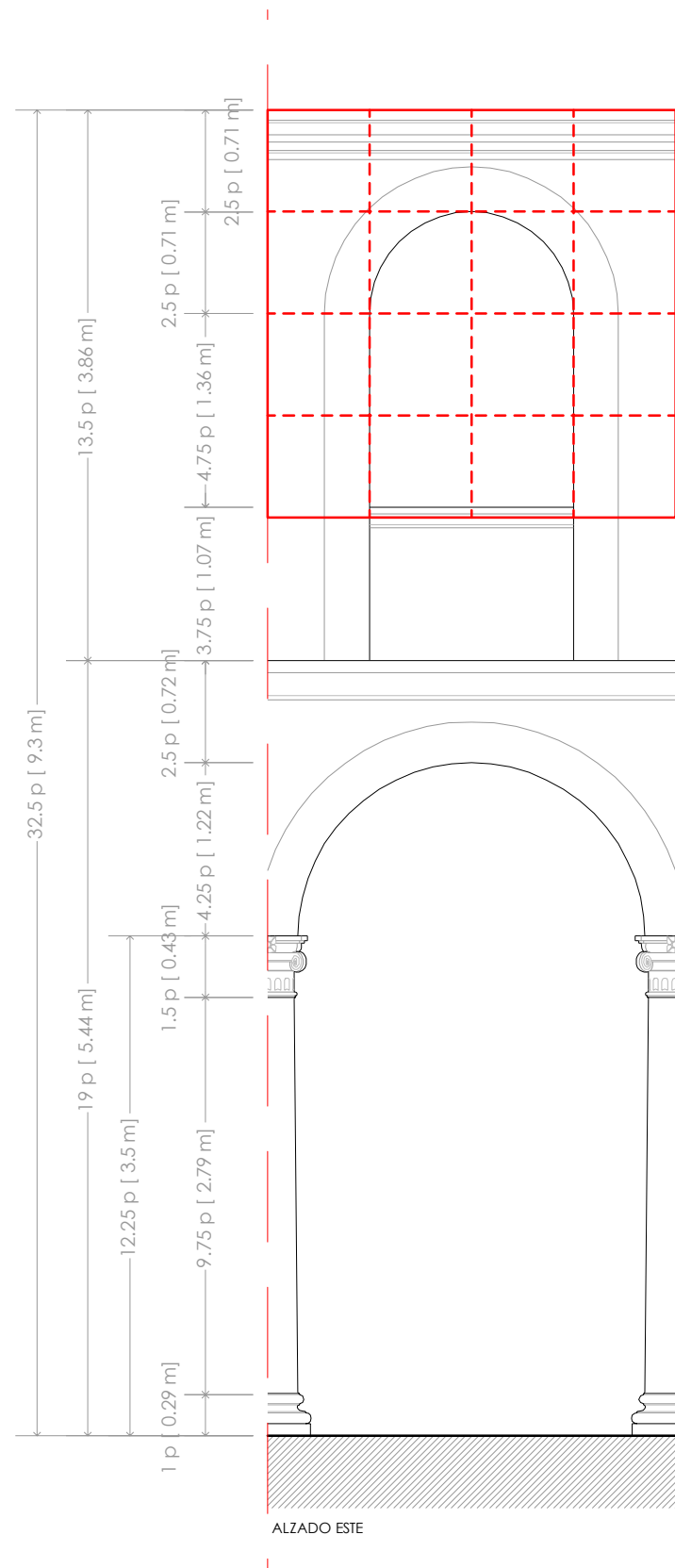

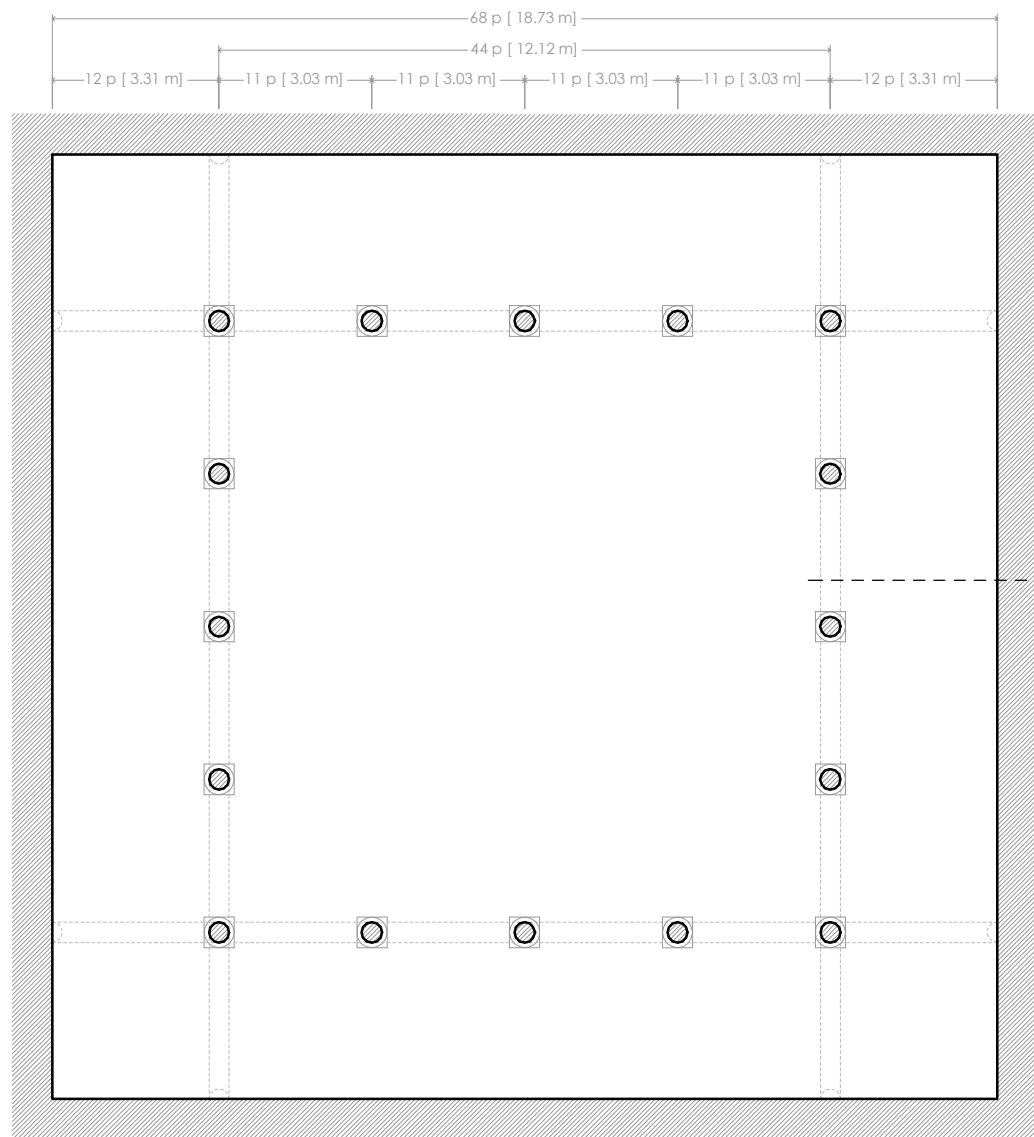

DETALLE ALZADO e:1/75 →

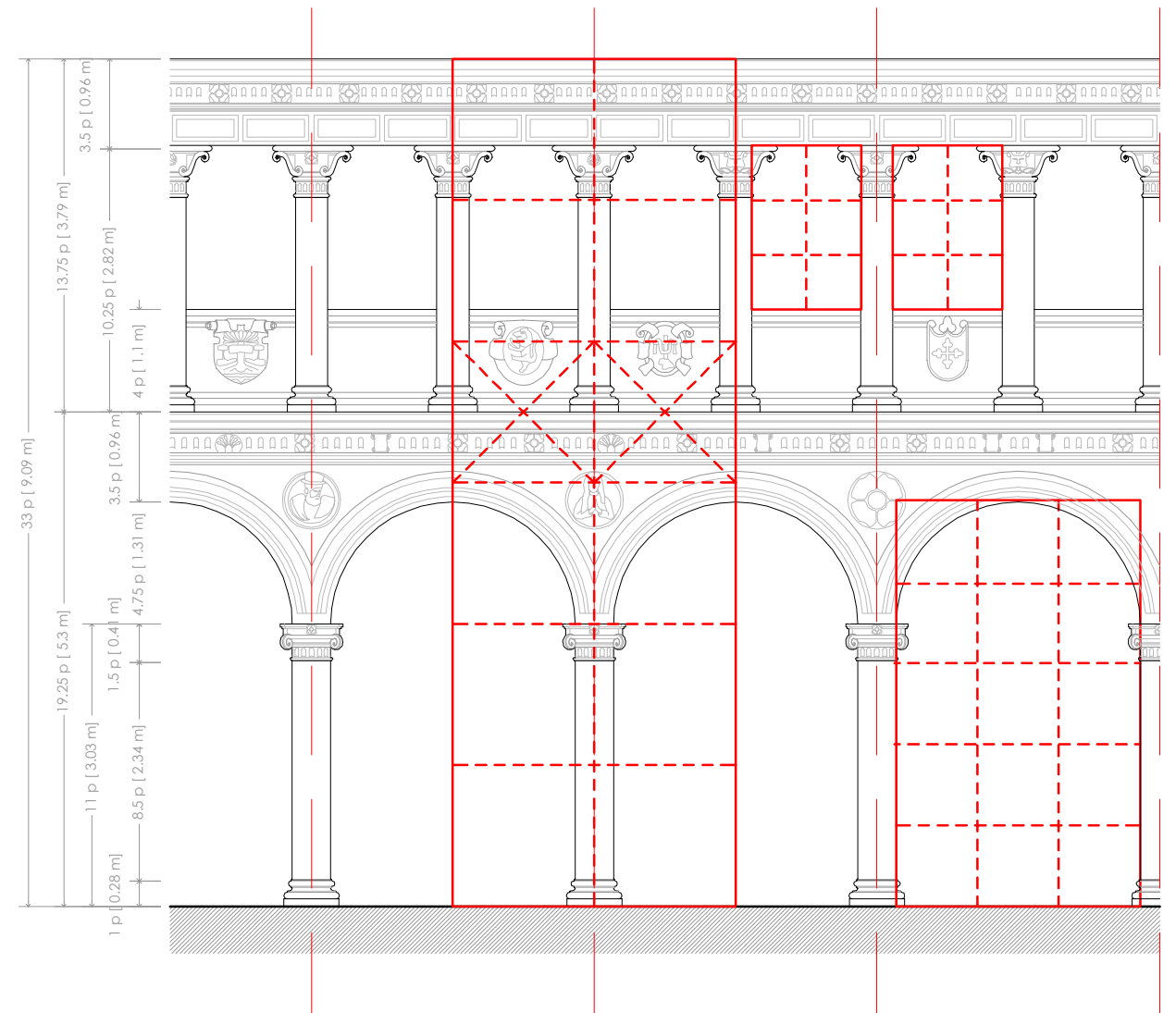

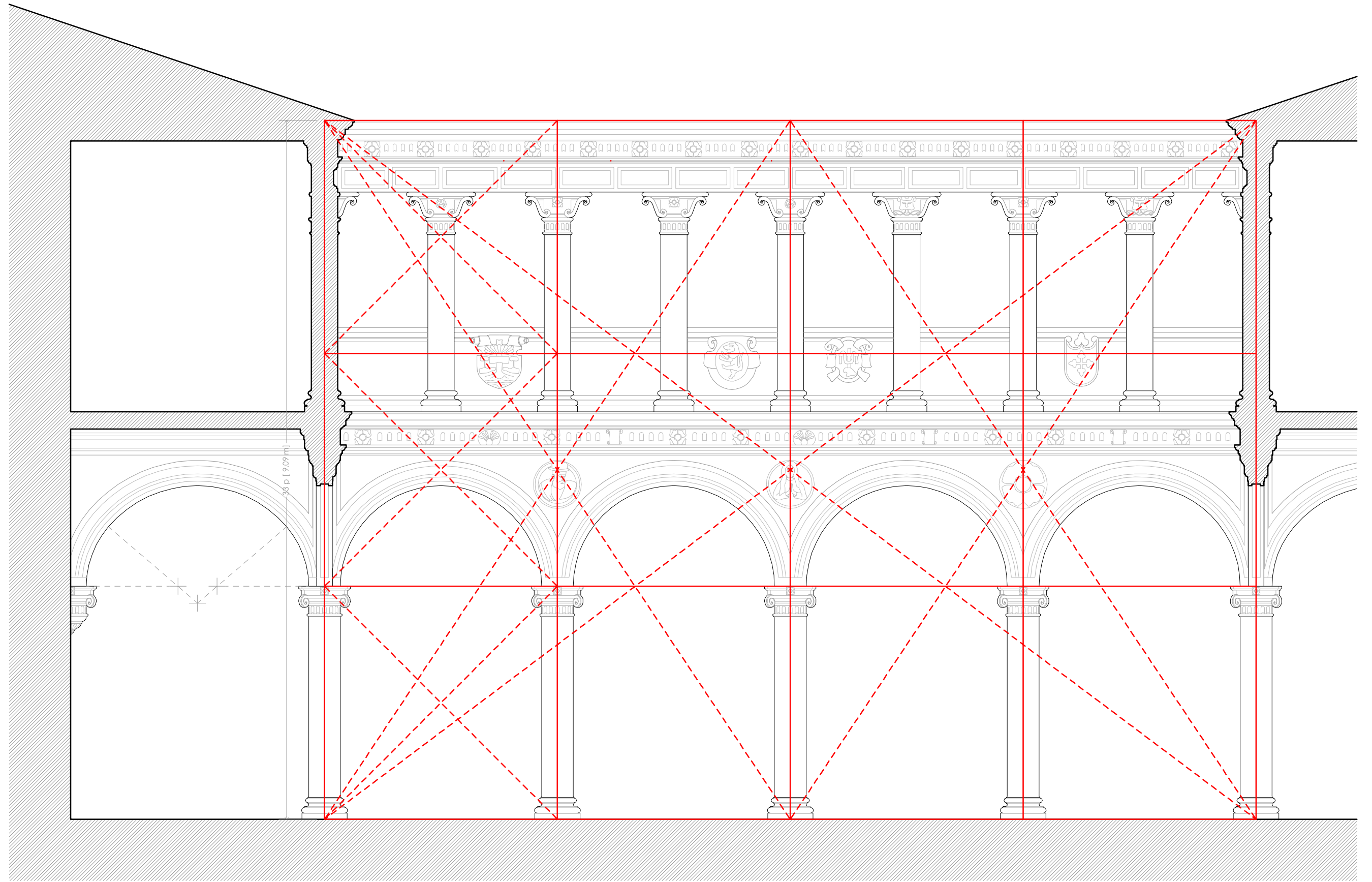

11 p [ 3.03 m ]

44 p [ 12.12 m ]



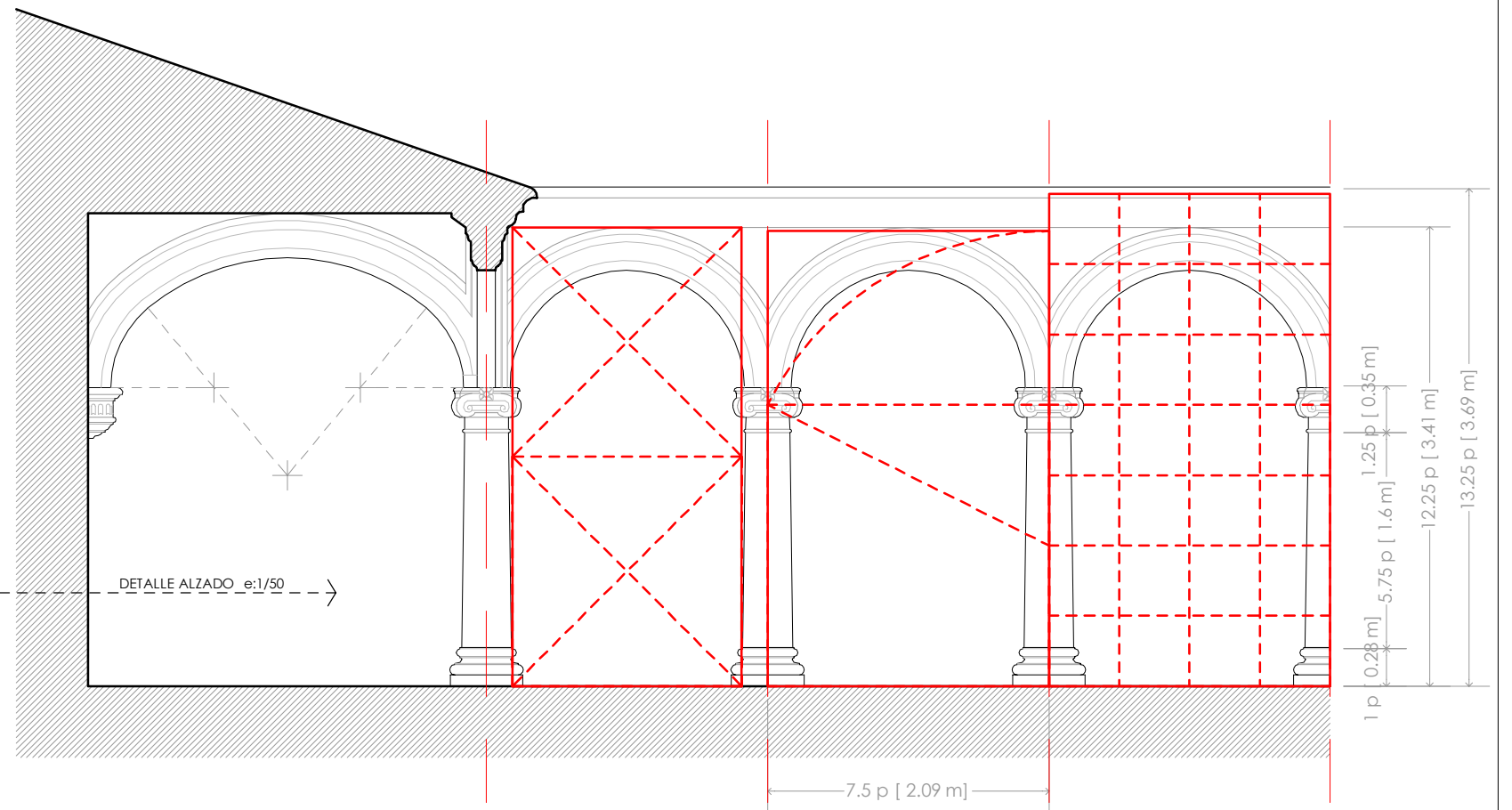
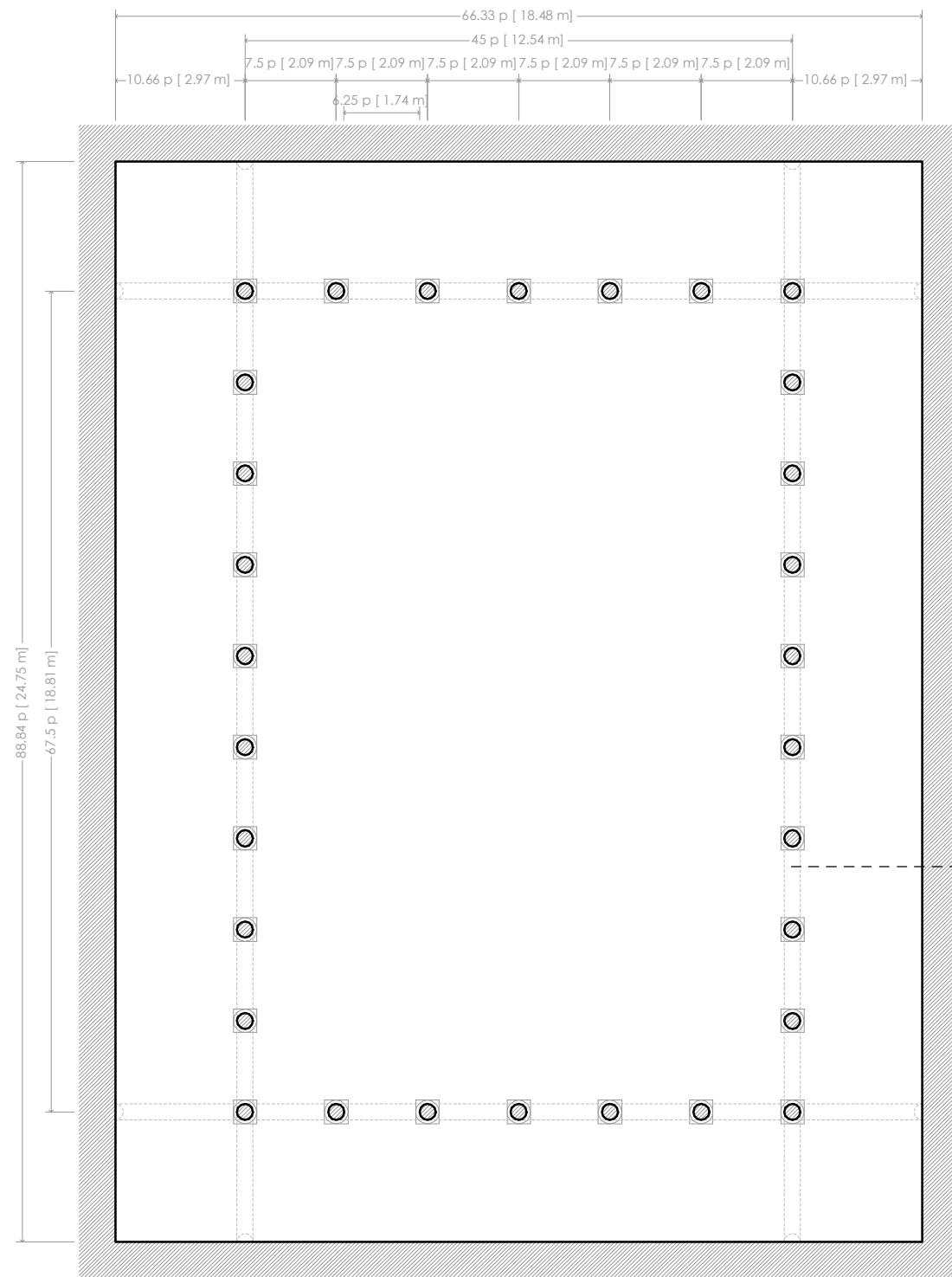

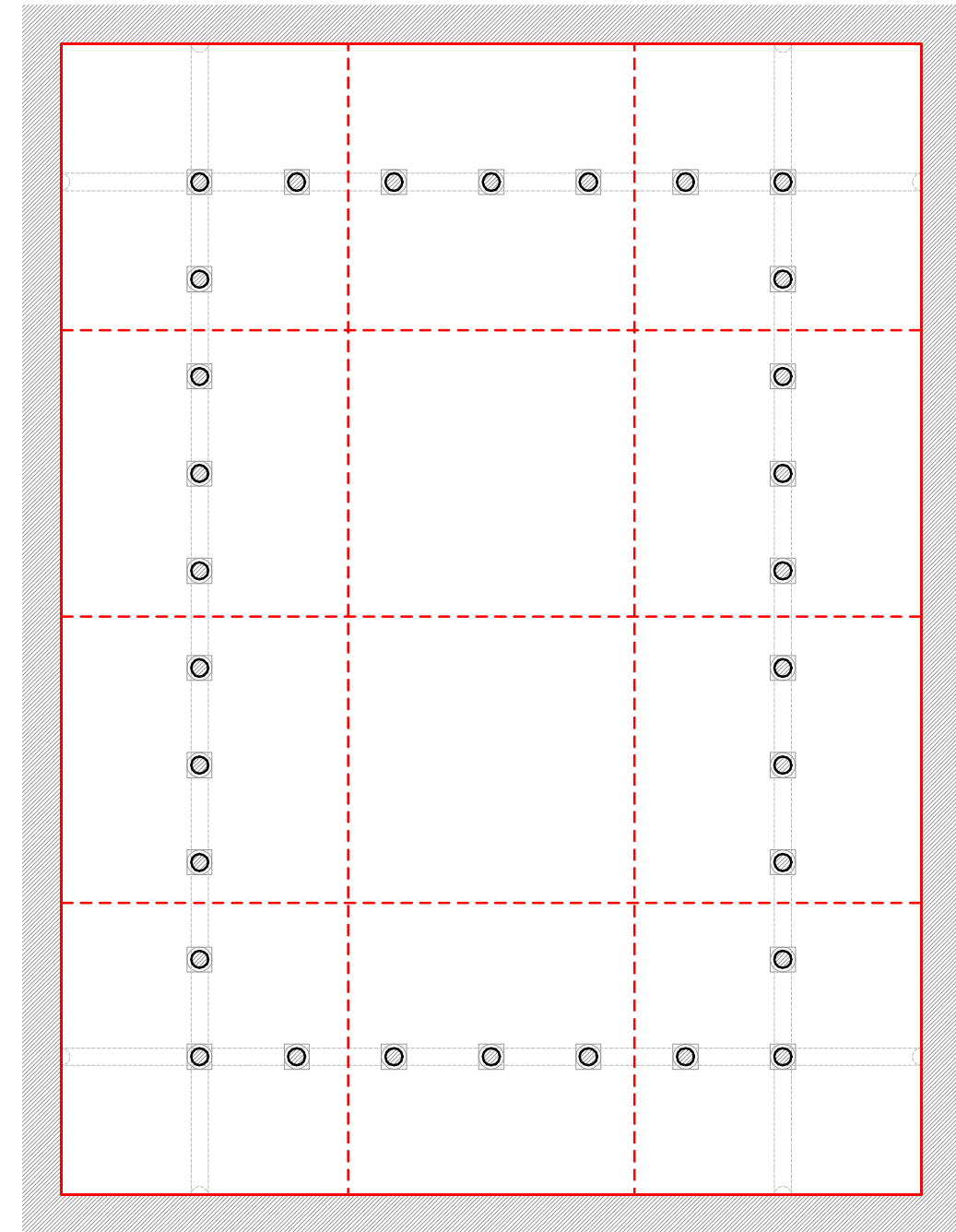
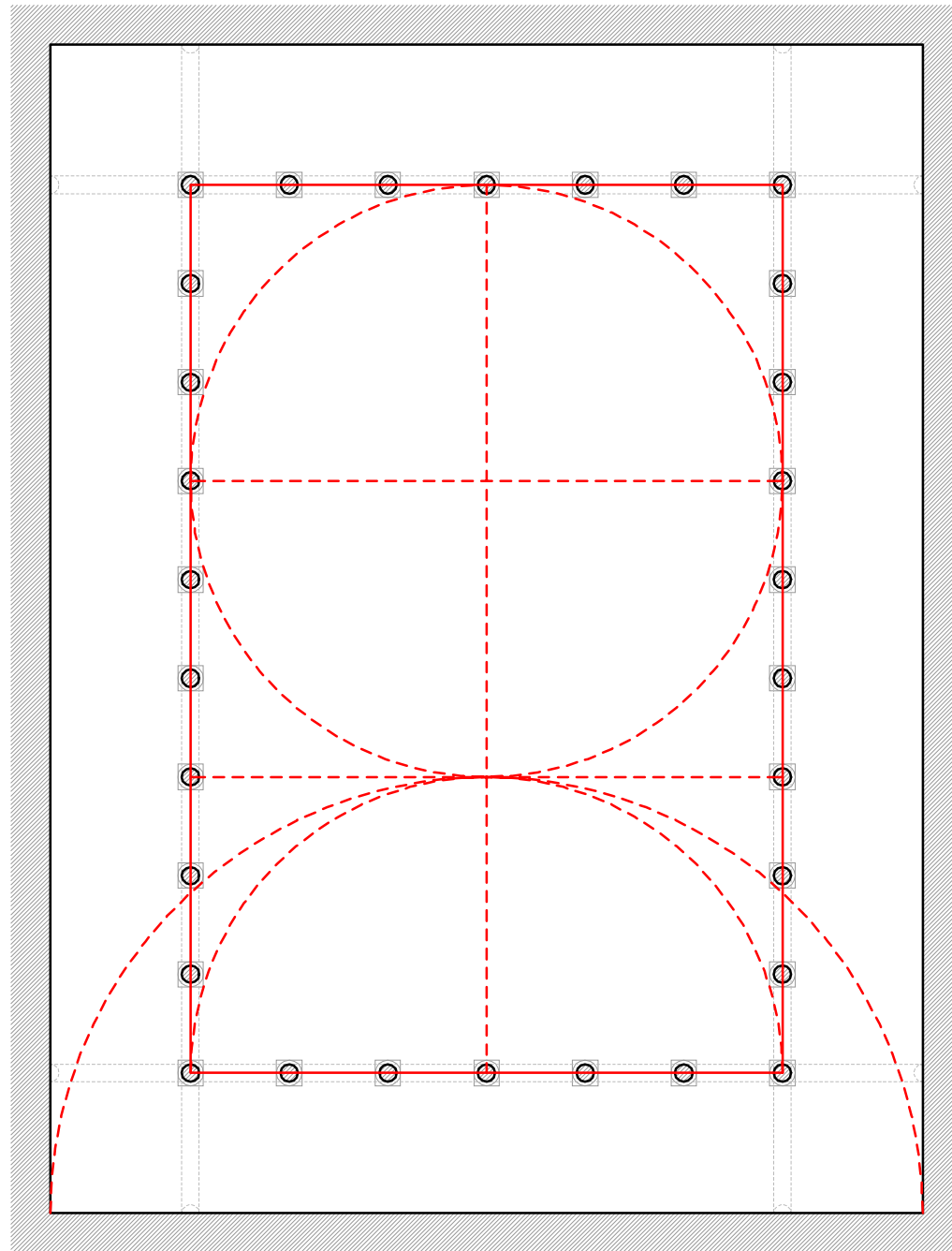

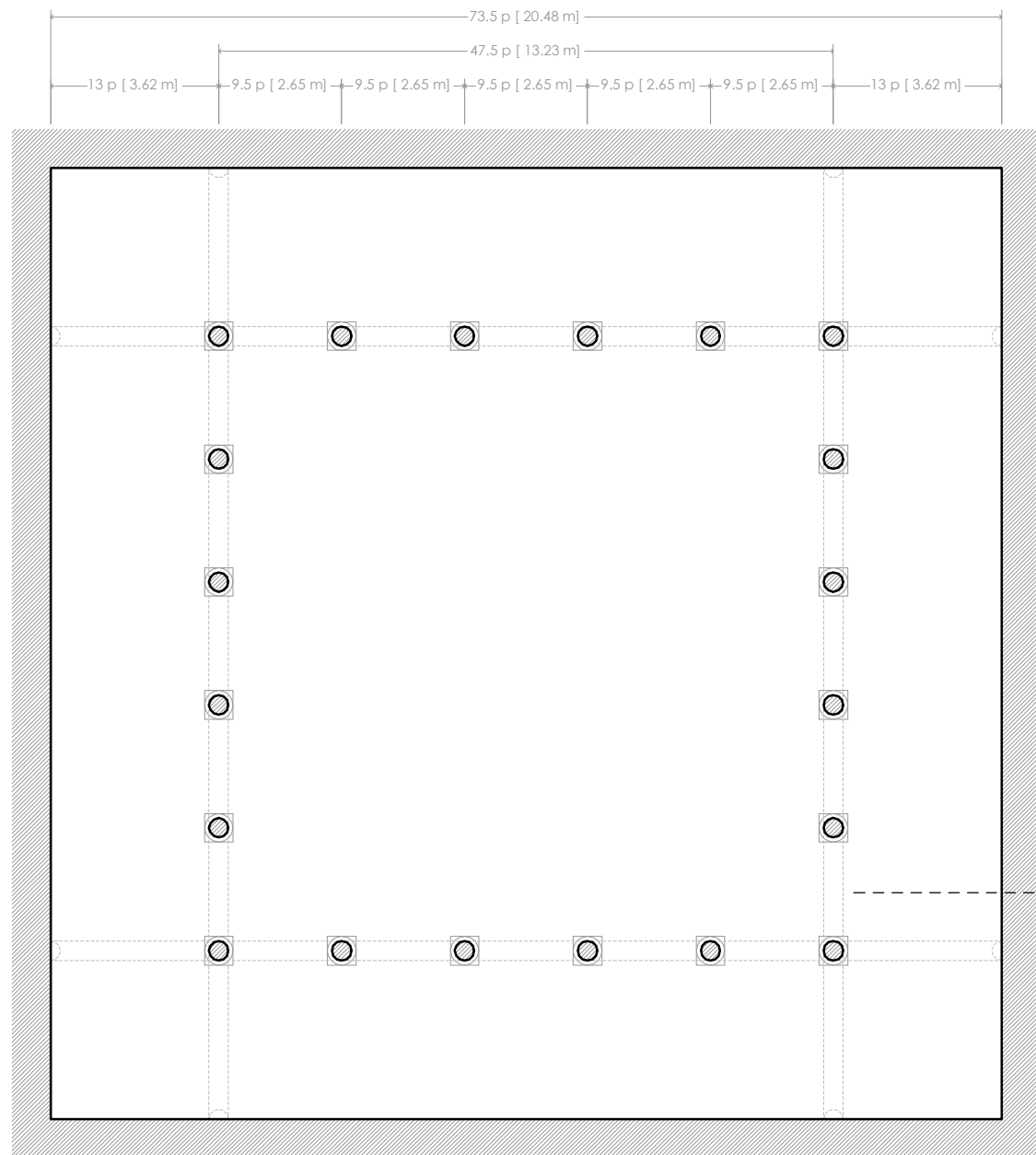

DETALLE ALZADO e:1/50 →

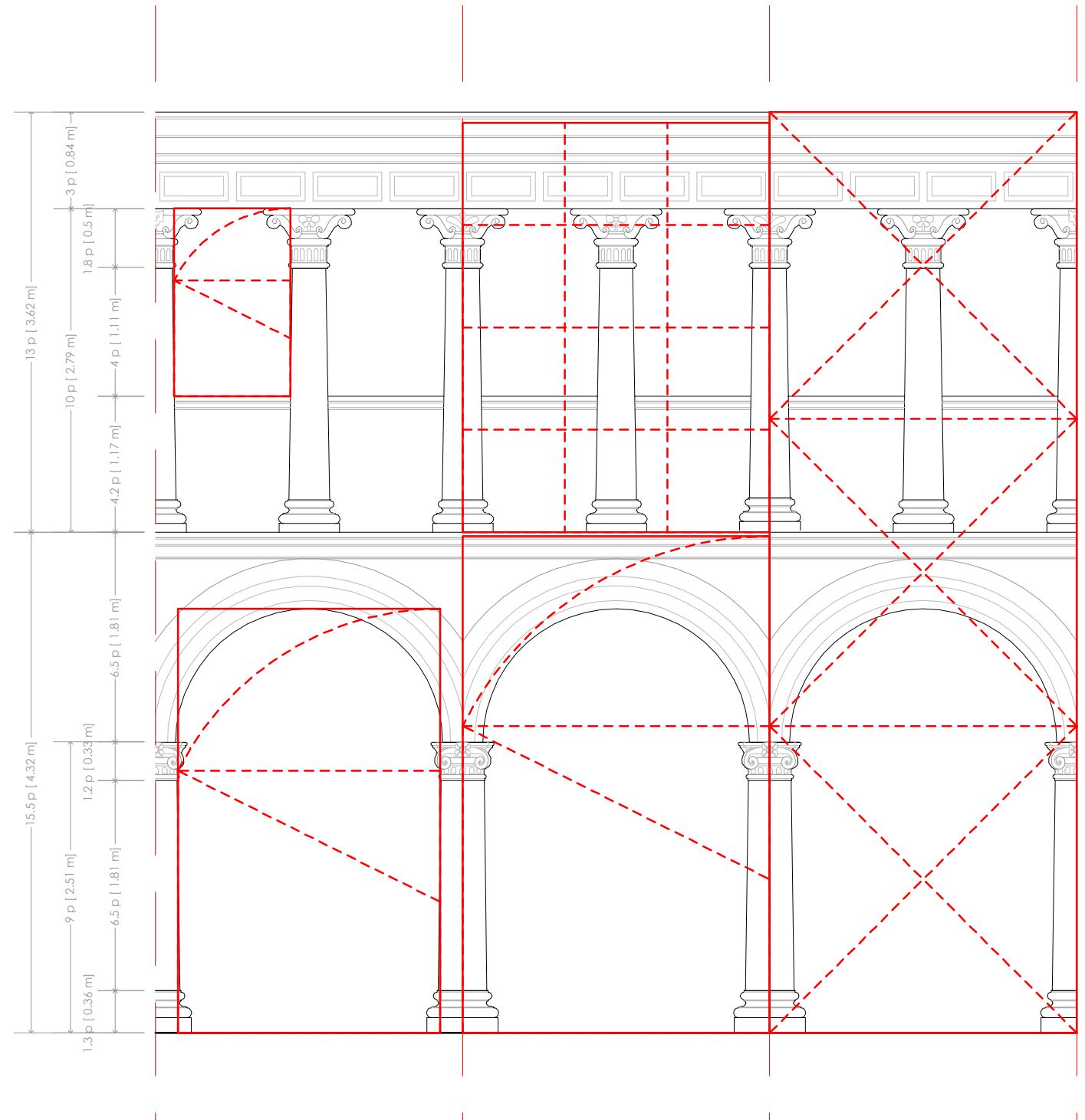

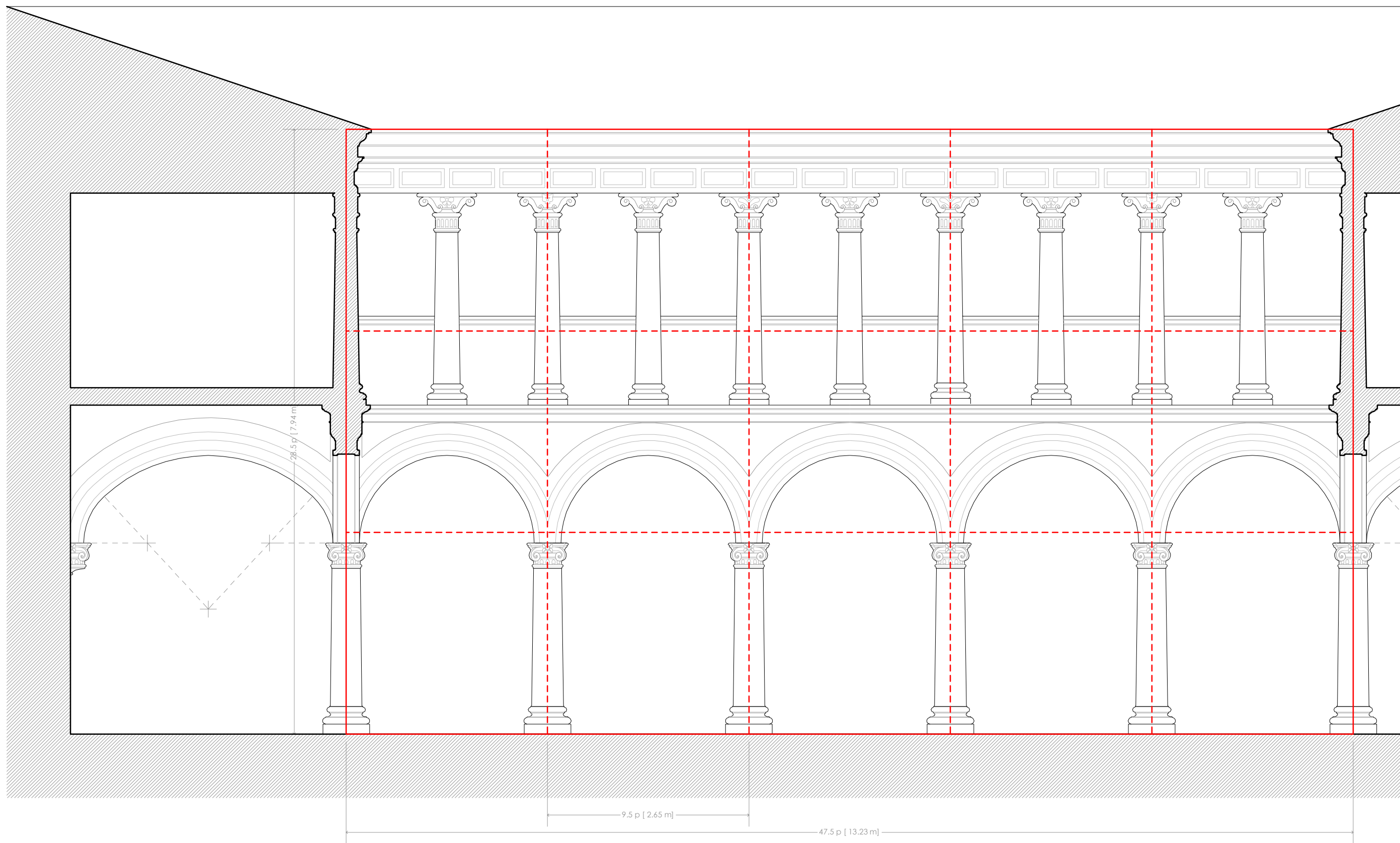

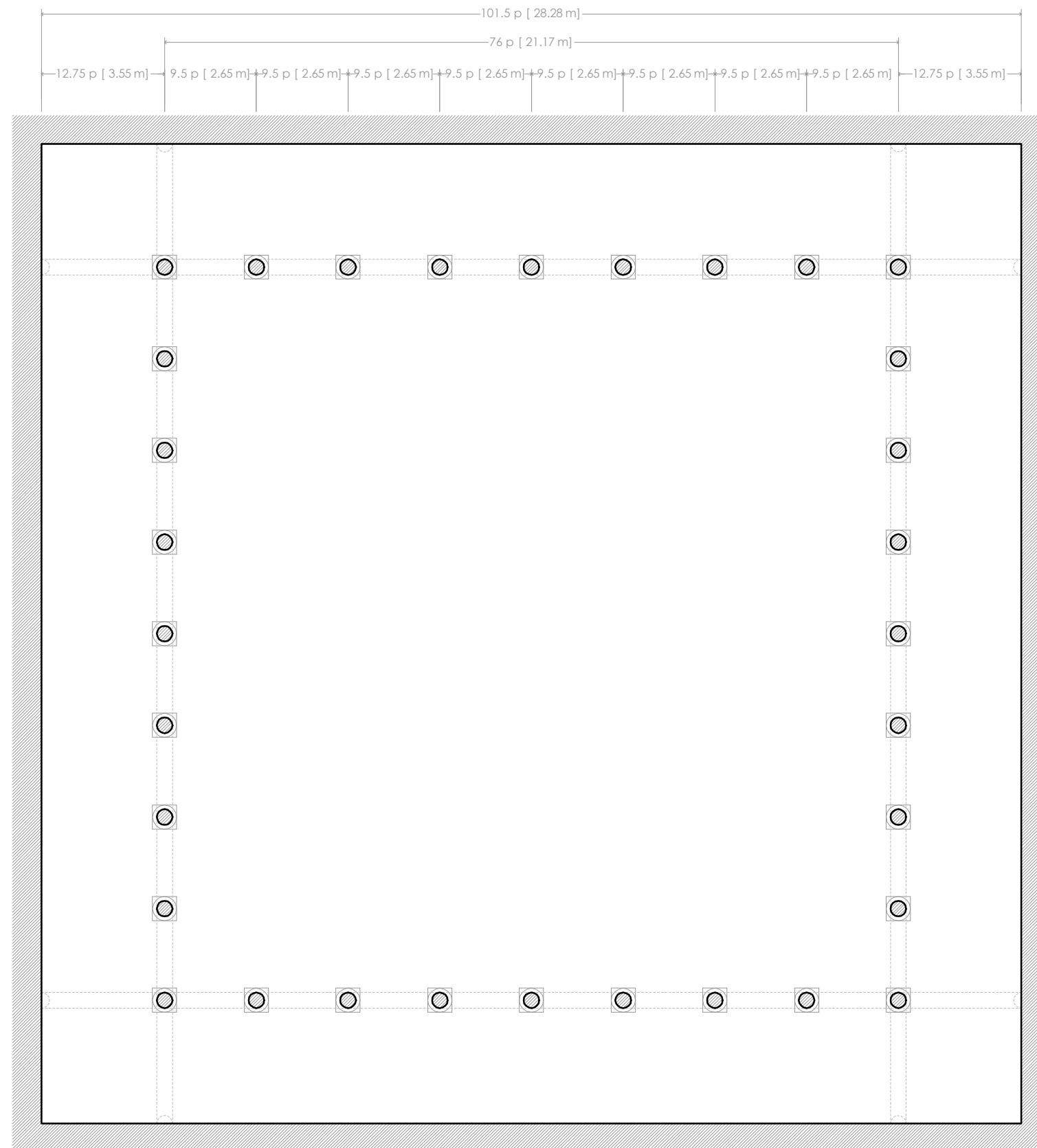



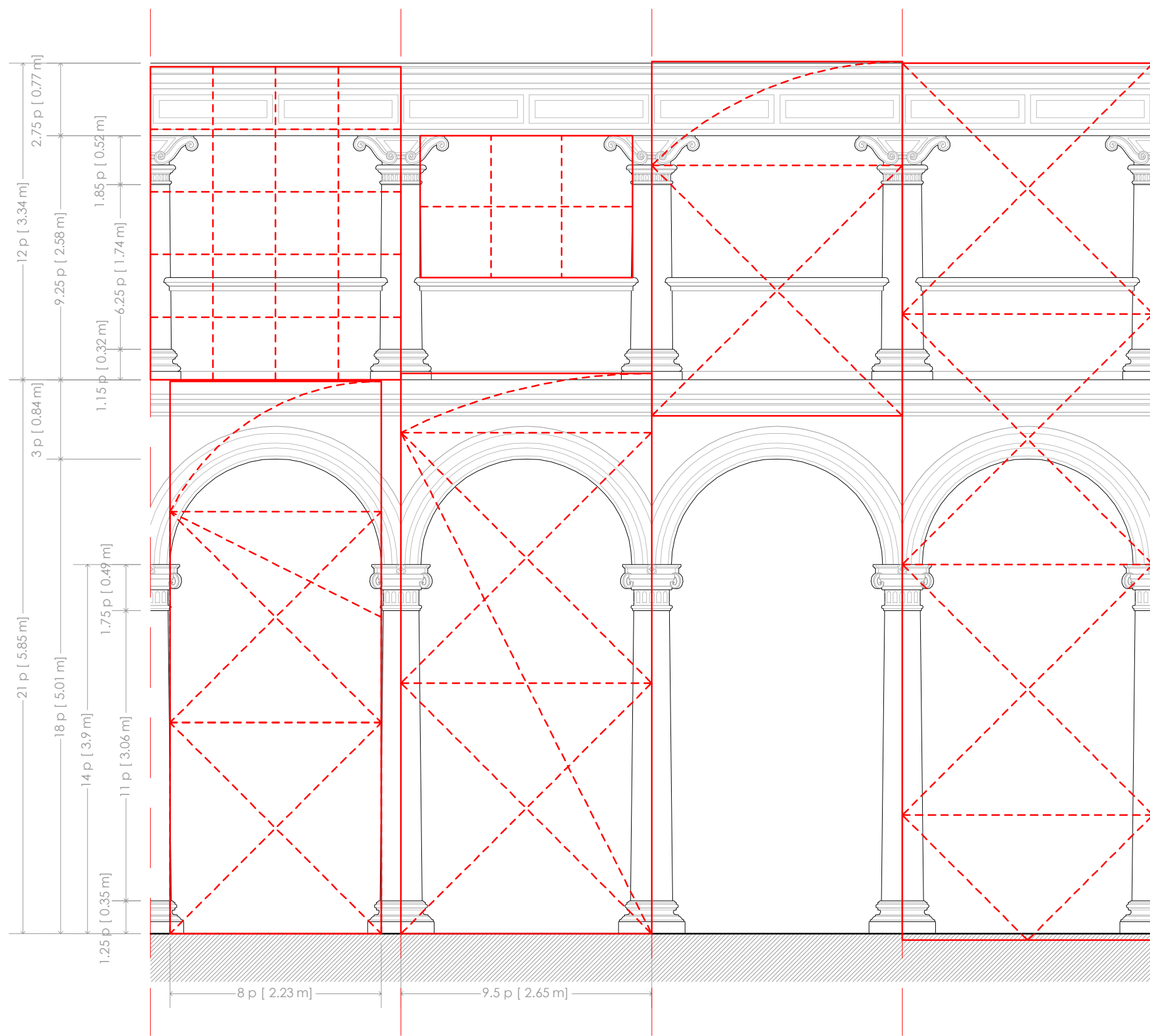

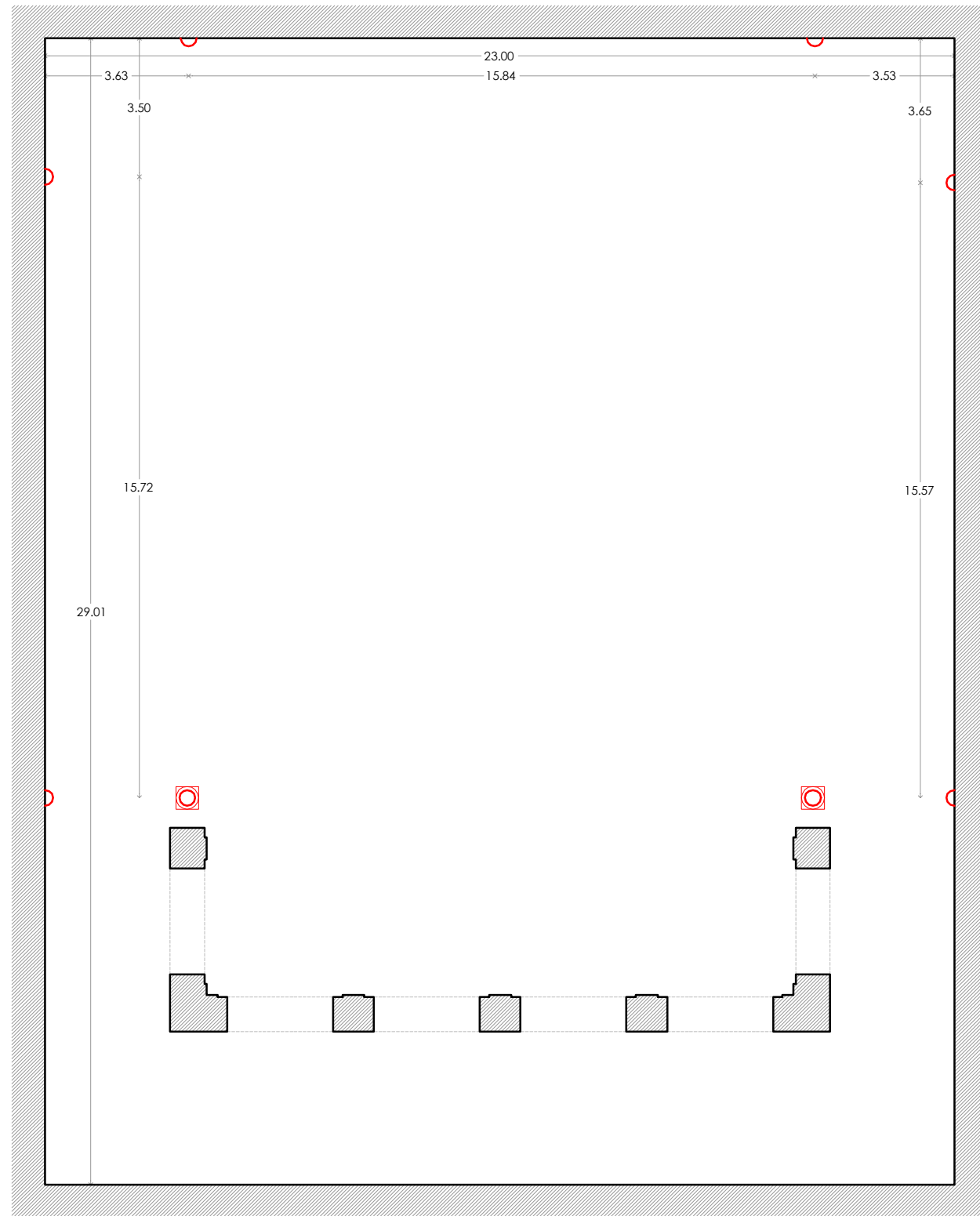

PLANTA ACTUAL  
 RESTOS DEL CLAUSTRO PÚBLICO EXISTENTES HOY EN DÍA

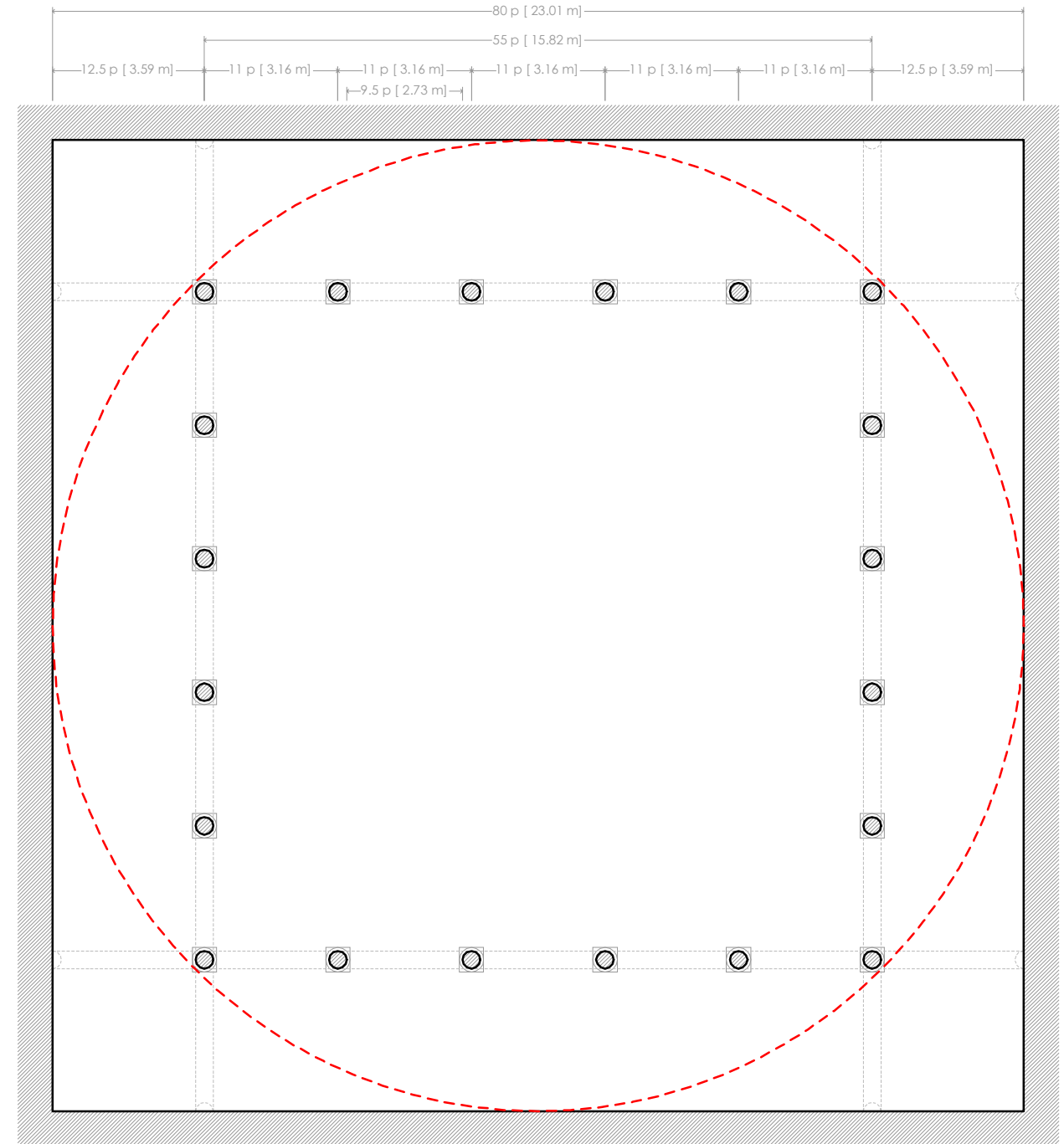

RECONSTRUCCIÓN PLANTA CLAUSTRO PÚBLICO

