

Preprint of the paper

"Efficient structural shape optimization: using directional high order sensitivity analysis to improve MP algorithms"

F. Navarrina, R. Tarrech, I. Colominas, G. Mosqueira, J. Gómez-Calviño, M. Casteleiro (2001)

Proceedings of the "6th US National Congress on Computational Mechanics", Dearborn, USA

<http://caminos.udc.es/gmni>

EFFICIENT STRUCTURAL SHAPE OPTIMIZATION: USING DIRECTIONAL HIGH ORDER SENSITIVITY ANALYSIS TO IMPROVE MP ALGORITHMS

F. Navarrina^a, R. Tarrech^a, I. Colominas^a, G. Mosqueira^a,
J. Gómez-Calviño^a and M. Casteleiro^b

^aDepartment of Applied Mathematics. Universidad de La Coruña, La Coruña, SPAIN
navarrina@iccp.udc.es

^bDepartment of Mechanical Engineering. Northwestern University, Evanston, USA
m-casteleiro@northwestern.edu

Any structural optimization analysis can be stated as a non linear constrained minimization problem [1]. And to solve this problem one seldom may use analytical techniques. On the other hand, integral methods —such as FEM, BEM or others— are frequently used for the computation of the structural response at every iteration. Therefore, one must take into account the large computational requirements of these sophisticated techniques and their sensitivity analysis [2] at the time of choosing a suitable algorithm for this kind of problems. Our goal is to develop a reliable, robust and efficient algorithm, with acceptable requirements of memory storage and computing time. Among the currently available Mathematical Programming algorithms, the Sequential Linear Programming (SLP) has proven to be quite adequate to be applied to structural optimization. However, diverse malfunctions may occur over the iterative process: the solution to the approximated linear problems can fail to exist, it may lead to a highly unfeasible point of the original non linear problem, and large oscillations often occur near the optimum, precluding the algorithm to converge.

We present in this paper an improved SLP algorithm with line-search, specially designed for structural optimization problems. An approximated linear problem with additional side constraints is solved in each iteration. The solution to this problem defines a search direction. Then, the objective function and the constraints are quadratically approximated in the search direction, and a line-search is performed. The algorithm includes strategies to avoid stalling at the boundary of the feasible region, and to obtain alternate search directions in the case of incompatible linearized constraints. The figure compares the performances of the SLP algorithm (a) and the proposed method (c) for the underconstrained academic test problem

$$\text{OBTAIN } (x, y) \text{ THAT MINIMIZES } f(x, y) = y \text{ SUBJECT TO } g(x, y) = x^2 - y \leq 0.$$

The directional high order information allows to remove the SLP characteristic large scale oscillations near the optimum (b), that are caused by the linearization. The proposed algorithm has been successfully applied by the authors to several shape optimization problems [2].

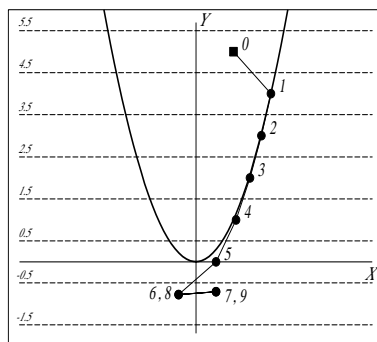

a)

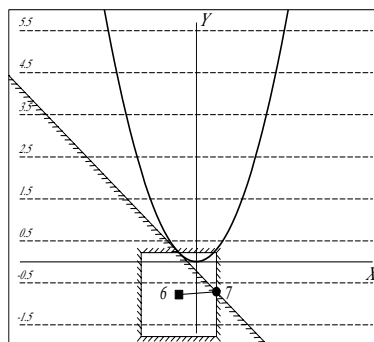

b)

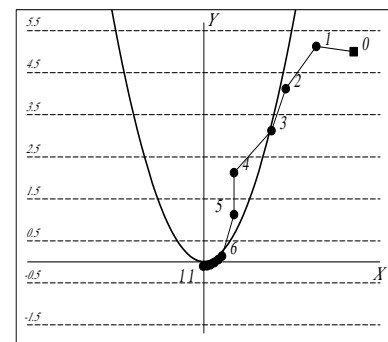

c)

References

- [1] F. Navarrina and M. Casteleiro, “A General Methodological Analysis for Optimum Design”, *Int. J. Num. Meth. Engrg.*, **31**, 85–111, 1991
- [2] F. Navarrina, S. López, I. Colominas, E. Bendito and M. Casteleiro, “High Order Shape Design Sensitivity: A Unified Approach” *Comp. Meth. in App. Mech. and Eng.*, **188**, 681–696, 2000