



UNIVERSIDADE DA CORUÑA



Escola Politécnica Superior

Trabajo Fin de Grado
CURSO 2021/2022

Petrolero VLCC con 300000 TPM

Grado en Ingeniería Naval y Oceánica

ALUMNO

Pedro Lemos González

TUTOR

Marcos Míguez González

FECHA

JUNIO 2022

PETROLERO VLCC DE 300000 TPM

Castellano:

El presente proyecto comprenderá el diseño de un buque petrolero de 300000 toneladas de peso muerto con 30 tripulantes que sea capaz de navegar grandes distancias típicas en este tipo de buques.

Concretamente este buque será diseñado para hacer el trayecto de carga en Arabia Saudita y descarga en Singapur, China y Japón. Además, la autonomía será de 18.000 millas (~29.000km).

El buque constará además con un sistema de propulsión de gas capaz de aprovechar los gases residuales de la carga de crudo con el fin de mejorar la eficiencia de la turbina de cara a la contaminación del medioambiente y de reducir las presiones en el interior de los tanques de crudo. El sistema de carga y descarga será por cámara de bombas y el resto de equipo e instalaciones serán los habituales en este tipo de buques.

Galego:

O presente proxecto comprenderá o deseño dun buque petroleiro de 300000 toneladas de peso morto con 30 tripulantes que sexa capaz de navegar grandes distancias típicas neste tipo de buques.

Concretamente este buque será deseñado para facer o traxecto de carga en Arabia Saudita e descarga en Singapur, China e Xapón. Ademáis, a autonomía será de 18 millas (~29.000km).

O buque constará ademáis cun sistema de propulsión de gas capaz de aproveitar os gases residuais da carga de crudo co fin de mellorar a eficiencia da turbina de cara á contaminación do medioambiente e de reducir as presións do interior dos tanques de crudo. O sistema de carga e descarga será por cámara de bombas e o resto de equipo e instalacións serán os habituais neste tipo de buques.

English:

The present project involves a crude carrier ship design of 300000 deathweight tonnage with 30 crew that it will be able to sail very large routes, typical in this kind of ships.

Particullary, this ship will be designed to do routes from Arabia Saudi in loading to Singapore, China and Japan in disloading. Moreover, the autonomy will be of 18.000 miles (~29.000 km).

This ship will consist in adition with a gas propulsion system that it wil be able to take advantage of residual gas from crude to improve the eficiencie of the turbine against the enviromental pollution. That's why the highest presures inside tanks must be reduced in order to difuse danger. Charge system will consist in a pump room and the rest of instalations will be the typical among these kind of ships.



UNIVERSIDADE DA CORUÑA



Escola Politécnica Superior

**TRABAJO FIN DE GRADO
CURSO 2021/22**

Petrolero VLCC de 300000 TPM

Grado en Ingeniería Naval y Oceánica

Cuaderno IV:

COMPARTIMENTADO Y CÁLCULOS DE ARQUITECTURA NAVAL.



GRADO EN INGENIERÍA NAVAL Y OCEÁNICA

TRABAJO FIN DE GRADO

CURSO 2021-2022

PROYECTO NÚMERO

TIPO DE BUQUE:

Petrolero

CLASIFICACIÓN, COTA Y REGLAMENTOS DE APLICACIÓN:

DNV, SOLAS y MARPOL.

CARACTERÍSTICAS DE LA CARGA:

300000 TPM. Crudos del petróleo y sus derivados con densidad máxima de 0.95 g/ml

VELOCIDAD Y AUTONOMÍA:

14.8 Knots de velocidad de servicio. 18.000 millas a velocidad de servicio.

SISTEMAS Y EQUIPOS DE CARGA / DESCARGA:

Cámara de bombas

PROPULSIÓN:

Motor convencional

Combustible: HFO (fuelóleo pesado) y LNG (gas natural licuado)

TRIPULACIÓN Y PASAJE: 30

OTROS EQUIPOS E INSTALACIONES: Los habituales en este tipo de buques.

Ferrol, 27 de junio de 2022

ALUMNO/A: **Dº Pedro Lemos González**

ÍNDICE

Petrolero VLCC de 300000 TPM.....	2
Índice	5
1 Introducción.	7
2 Definición de cuadernas, bulárcamas y estructura longitudinal.	9
2.1 Separación de cuadernas, posición de bulárcamas y numeración.	9
3 Compartimentado longitudinal.....	11
3.1 Separación de longitudinales.	11
3.2 Pique de popa.....	11
3.3 Cámara de máquinas.....	11
3.4 Cámara de bombas.	12
3.5 Tanques de carga.	12
3.6 Tanques de lastre.	13
3.7 Pique de proa o mamparo de colisión.	13
4 Compartimentado transversal.	15
4.1 Doble casco.....	15
4.2 Mamparos principales y de colisión.	15
5 Compartimentado vertical.	16
5.1 Justificación de la altura de doble fondo.	16
5.2 Mamparos longitudinales.	17
6 Dimensionado y número de tanques.....	18
6.1 Tanques del sistema de combustible.	18
6.1.1 Tanques de fuelóleo pesado (HFO).	18
6.1.2 Tanques de gas natural licuado (LNG).	20
6.1.3 Resumen de resultados y tanques de combustible.	21
6.2 Tanques de agua dulce.....	21
6.3 Tanques de aceite.	23
6.4 Tanques de aguas aceitosas y lodos.	23
6.5 Comprobación de la regla 12A del MARPOL en lo aplicable.....	24
6.6 Código IGF para tanques de LNG.....	25
6.7 Comprobación de espacio para motor.	26
7 Zona estanca, puntos de inundación y cálculos de arquitectura naval.	29
8 Calibrado de los tanques.....	30

9 Espacios de carga y justificación de cumplimiento de la RPA.	33
10 Cálculo de las curvas hidrostáticas.	34
11 Curvas de KN.....	70
12 Bibliografía.	101
13 Anejo I: Vistas 3D de Maxsurf Stability.....	102
14 Anejo II: Planos.	105

1 INTRODUCCIÓN.

En este cuaderno se calculará principalmente lo siguiente:

- Tablas hidrostáticas y de KN's puntos de inundación progresiva.
- Justificación del compartimentado y justificación de tanques.
- Justificación de espacios de carga.
- Disposición de tanques y tablas de capacidades.
- Comprobación de los resultados.

Las dimensiones del buque proyecto son:

L_{pp}	325 m
L_{TOTAL}	339,3 m
B	60 m
D	30 m
T	19,665 m
C_b	0,83
C_m	0,99
C_p	0,80
C_{wp}	0,88
Δ	365.984 ton
P_{rosca}	46.442,83 ton
Superficie Mojada	28.080,829 m ²
Velocidad	14,8 Knots
Semiángulo de entrada	51°
Potencia al 85%MCR	39.930,71 kW
RPM	86
Coste de Adquisición	126.795.908,8 €

Este cuaderno se basará prácticamente en su totalidad en el programa de modelado de buques MAXSURF Modeler. Por tanto, todos los datos, tablas y gráficas serán de dicho programa.

2 DEFINICIÓN DE CUADERNAS, BULÁRCAMAS Y ESTRUCTURA LONGITUDINAL.

2.1 Separación de cuadernas, posición de bulárcamas y numeración.

Los valores máximos de separación de cuadernas para nuestro buque serán:

ZONA	MÁXIMO (mm)
Cuerpo de proa	$470+(L/0.6) = 1011$
Cámara de máquinas	700
Cuerpo central	$510+(L/0.6) = 1051$
Cuerpo de popa	$470+(L/0.6) = 1011$

Para no superar los valores de la tabla anterior se establecen valores para la separación de cuadernas de buques típicas de este tipo de buques:

- Cuerpo de popa: 700 mm
- Cámara de máquinas: 700 mm
- Cuerpo central: 1000 mm
- Cuerpo de proa: 700 mm

Se dispondrá a su vez de una bulárcama cada 4 cuadernas en espacio de carga y de una bulárcama cada tres cuadernas en zonas de popa y proa.

La zona de popa comprenderá desde el espejo de popa hasta la sección situada a 60 metros de la perpendicular de popa, de forma que la eslora total de la zona de popa será de 68,962 metros. Por tanto, se tendrán un total de 65 cuadernas y 32 bulárcamas separadas 700 mm entre sí.

El espacio de carga comprenderá desde la sección situada a 60 metros de la perpendicular de popa hasta la sección situada a 290 metros de la perpendicular de popa, de forma que la eslora total de la zona de carga será de 230 metros. Por tanto, se tendrán un total de 184 cuadernas y 46 bulárcamas separadas 1000 mm entre sí.

La zona de proa comprenderá desde la sección situada a 290 metros de la perpendicular de popa hasta el punto más a proa del buque situado a 330,3 metros de la perpendicular de popa, de forma que la eslora total de la zona de proa será de 40,3 metros. Por tanto, se tendrán un total de 38 cuadernas y 19 bulárcamas separadas 700 mm entre sí.

Para facilitar la numeración meteremos las bulárcamas en la lista de numeración de cuadernas de forma que a efectos de lectura se cuenten como si también fuesen cuadernas.

Según lo visto en los párrafos anteriores, en la zona de popa tenemos un total de 97 cuadernas desde el espejo de popa a la cuaderna número 97, colocada a 67,9 metros del espejo de popa y a 58,9 metros de la perpendicular de popa. En la zona de carga tenemos un total de 230 cuadernas desde la cuaderna número 98, colocada a 60 metros de la perpendicular de popa, a la cuaderna número 327, colocada a 290 metros de la perpendicular de popa. Por último, la zona de proa estará compuesta por 57 cuadernas y comprenderá desde la cuaderna número 328, colocada a 290,70 metros de la perpendicular de popa, hasta la cuaderna número 384, situada a 329,90 metros de la perpendicular de popa.

Cabe destacar que la perpendicular de popa, situada a 8,962 metros del espejo de popa no coincide con ninguna cuaderna físicamente, sino que será una línea constructiva de diseño.

A continuación, ponemos una tabla resumen de lo explicado en este apartado:

ZONAS	NUMERO DE CUADERNAS
POPA	Nº 0 → Nº 97 (67,90 m)
CARGA	Nº 98 → Nº 327 (230 m)
PROA	Nº 328 → Nº 384 (39,90 m)

3 COMPARTIMENTADO LONGITUDINAL.

3.1 Separación de longitudinales.

En este proyecto se establecen dos longitudinales a lo largo de la zona de carga del buque para la correcta división de tanques (véase nuestro buque de referencia). Como nuestra manga es de 60 metros y el doble casco de 3 metros, tenemos 54 metros de manga disponible para tanques (en el cuerpo cilíndrico), por lo cual a priori nos resulta viable establecer tres tanques de 18 metros de manga cada uno. Ello implica directamente que los longitudinales estarán posicionados 9 metros a babor y estribor de la línea de crujía.

A continuación, se muestra una vista en planta de la distribución del petrolero DIJILAH, nuestro buque de referencia:

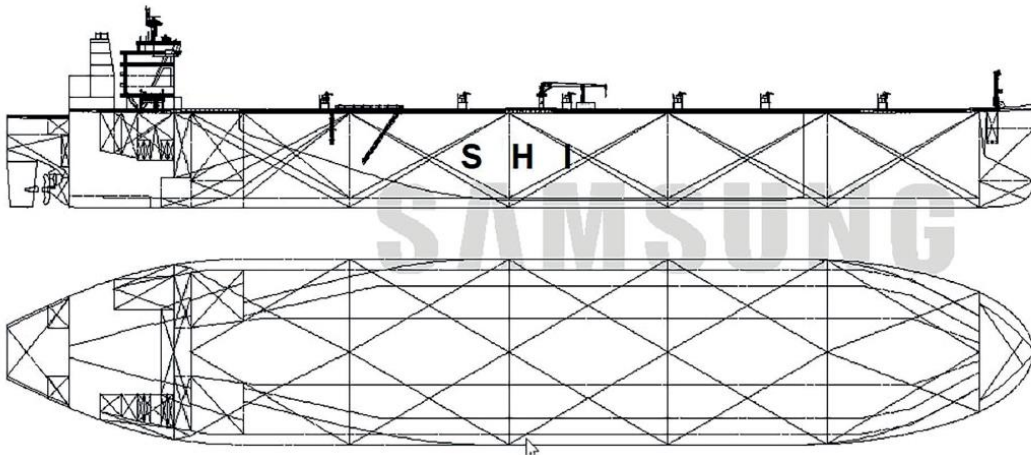

3.2 Pique de popa.

El pique de popa, al no definirse en ningún apartado de nuestra sociedad de clasificación (DNV), vamos a definirlos según la asignatura de Proyectos del buque I como el 4% de la eslora entre perpendiculares:

$$L_{\text{pique popa}} = 13 \text{ m} \rightarrow \text{Cuaderna n}^{\circ}19 \text{ (4,3 m a proa de perpendicular de popa)}$$

3.3 Cámara de máquinas.

Se sitúa justo a continuación del pique de popa y su dimensión viene definida por:

$$L_{cm} = 0.28 * L_{pp}^{0.67} + 0.48 * MCO^{0.35}$$

Como se puede observar dependerá de la eslora de nuestro buque y de la potencia del motor del mismo (41.220 kW).

$$L_{cm} = 33,29 \text{ m} \rightarrow \text{Cuaderna n}^{\circ}44 \text{ (21,8 m de perpendicular de popa)}$$

Cabe destacar en este apartado que existirán dos entrepuentes de máquinas. Dichos puentes se situarán a 13 metros (cubierta N°2) y a 24 metros (cubierta N°3) sobre la línea de base.

Los tanques de almacén de combustible y los tanques de aceite apoyarán sobre la cubierta N°2, concretamente a 9,5 metros del doble fondo.

3.4 Cámara de bombas.

Se debe mencionar en este punto que la cámara de bombas también se situará en la cámara de máquinas, concretamente en la cubierta del doble fondo (cubierta N°1), inmediatamente a proa del motor principal.

Según el SOLAS (Capítulo II-2, Parte B, 5), las cámaras de bombas se situarán a proa de los espacios de máquinas. Es decir, en este tipo de buques es común que las cámaras de bombas se sitúen encajadas en la proa de cámara de máquinas. En este caso, se situará la cámara de bombas de esta manera, y los motores que accionarán las bombas estarán dentro de la cámara de máquinas. Esto se hace así porque la cámara de bombas, al igual que los tanques de carga, se considera un espacio peligroso.

3.5 Tanques de carga.

En este caso y basándonos en el buque de referencia nosotros dispondremos de 15 tanques, distribuidos en grupos de tres (dos laterales y uno central) y en 5 filas a lo largo del eje longitudinal del buque.

La longitud máxima de los tanques la regula el convenio MARPOL (Regla 24, Capítulo III, Anexo 1), a través de la tabla que se observa a continuación:

Number of longitudinal bulkheads inside cargo tanks		One (on centreline)	Two	Three (one on centreline)	Where no longitudinal bulkhead is arranged or where longitudinal bulkheads are perforated across breadth of cargo tanks
Length of wing cargo tank		$\left(0,25 \frac{b_1}{B} + 0,15\right) L_L$	$0,2L_L$	$0,2L_L$	$\left(0,5 \frac{b_1}{B} + 0,1\right) L_L$ or $0,2L_L$ whichever is the lesser
Length of centre tank	$b_1 \geq 0,2B$	—	$0,2L_L$	$0,2L_L$ port and starboard	
	$b_1 < 0,2B$	—	$\left(0,5 \frac{b_1}{B} + 0,1\right) L_L$	$\left(0,25 \frac{b_1}{B} + 0,15\right) L_L$ port and starboard	
NOTE The symbols L_L , B and b_1 are defined in 1.5.					

En nuestro caso usaremos dos mamparos longitudinales (como en el buque de referencia; DIJILAH en *Significants Ships of 2019*), por tanto, la longitud de nuestros tanques será, según el convenio:

$$L_{TANQUES DE CARGA} = 0.2 * L_L$$

L_L podemos definirla como el 96% de la eslora de flotación al 85% del puntal, o bien la eslora entre perpendiculares al 85% del puntal, la mayor de las dos.

Nuestra eslora de flotación al 85% del calado es de 333,962 metros, por tanto, el 96% de dicho valor será de 320,60 metros. Sin embargo, nuestra eslora entre perpendiculares independientemente del puntal es de 325 metros.

En nuestro caso la mayor será el 96% de la eslora de flotación al 85% del puntal, que serán 320,60 m, por tanto:

$$L_{TANQUES DE CARGA} = 64,12 \text{ m}$$

Dicho esto, podremos implantar la idea de 15 tanques de carga como en nuestro buque de referencia, algo muy común en este tipo de buques y se puede afirmar que la eslora de tanques será menor que la máxima recogida en el MARPOL.

La disposición de los tanques será del tipo siguiente:

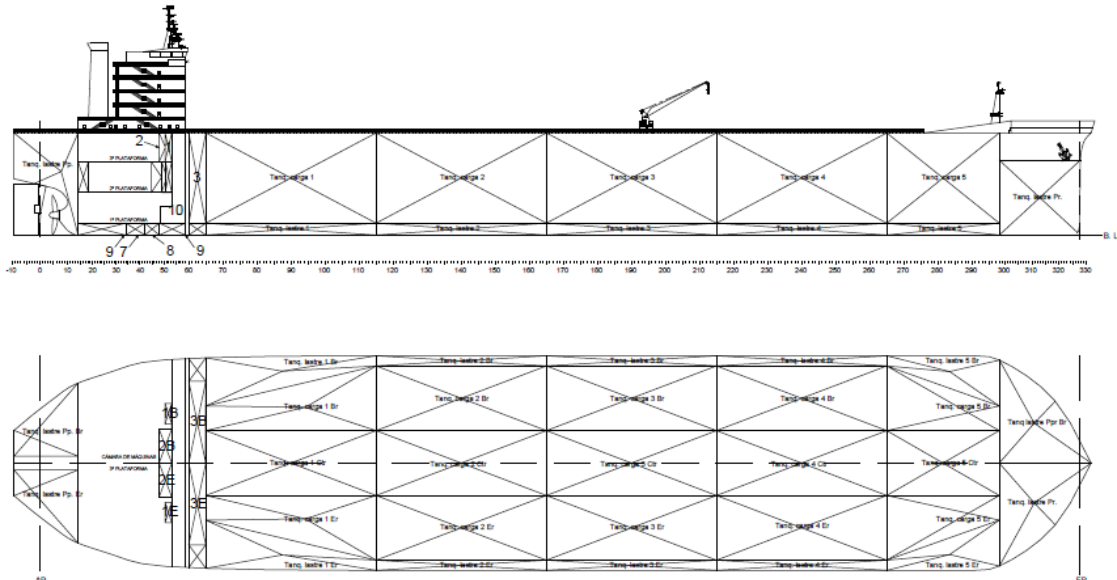

La línea de tanques que comprende desde el tanque más a popa hasta la cuarta fila de tanques hacia proa se compondrá de tanques de 50 m de largo y 20 m de ancho, tanto los centrales como los laterales. Sin embargo, los tanques situados más proa, es decir, la última fila de tanques será diseñada para tener una forma que se ajuste a las formas de nuestro buque, sólo el tanque central tendrá una forma estrictamente rectangular y, además, ésta última fila tendrá 60 m de longitud para aprovechar mejor las formas más afiladas de proa.

Se deberá restar de estas dimensiones los valores de doble casco (3 m) y los de doble fondo (3,5 m).

3.6 Tanques de lastre.

El MARPOL (Regla 13, Capítulo II, Anexo 1) dispone lo siguiente:

1) Todo buque petrolero de crudo de peso muerto mayor a 20.000 ton irá provisto de tanques de lastre separados.

2) La capacidad de los tanques de lastre será aquella que permita operar al buque con seguridad.

No se transportará nunca agua de lastre en los tanques de carga excepto en los casos:

- Condiciones meteorológicas adversas.
- Particularidades del servicio.

3.7 Pique de proa o mamparo de colisión.

El DNV exige una distancia mínima y máxima entre el mamparo del pique de proa y la perpendicular de proa. En la siguiente tabla se regulan dichas distancias:

Arrangement	Length L_L , in metres	Distance of collision bulkhead aft of fore end of L_L , in metres	
		Minimum	Maximum
(a)	≤ 200	$0,05L_L$	$0,08L_L$
	> 200	10	$0,08L_L$
(b)	≤ 200	$0,05L_L - f_1$	$0,08L_L - f_1$
	> 200	$10 - f_2$	$0,08L_L - f_2$

Como se puede observar nuestro buque es de tipo "a" (por no tener superficie sumergida por fuera de L_L) y al tener más de 200 m de eslora tendrá un mínimo y un máximo de:

$$10 < x < 0.08 * L_L$$

En nuestro caso L_L vale 320,60 m, por tanto, los valores mínimo y máximo serán:

$$MIN = 10 \text{ m}$$

$$MAX = 25,64 \text{ m}$$

Dentro de estos rangos escogeremos el valor máximo de nuestro pique de proa, en este caso y si observamos los planos y los anexos del cuaderno, vemos que el pique de proa se sitúa a 307 metros a proa de la perpendicular de popa y por tanto, 18 metros a popa de la perpendicular de proa, por tanto se puede afirmar que sí nos encontramos entre los valores máximo y mínimo calculados en este apartado, pues:

$$10 \text{ m} < \mathbf{18 \text{ m}} < 25,64 \text{ m} \rightarrow \text{Cumple!}$$

El SOLAS, por su parte (regla 10, Parte B: Compartimentado y estabilidad), dice lo siguiente:

“Se instalará un mamparo de pique de proa o de colisión que será estanco hasta la cubierta de cierre. Este mamparo estará situado a una distancia de la perpendicular de proa no inferior al 5% de la eslora del buque ni superior a 3 m más el 5% de la eslora del buque”.

Es decir:

$$MIN = 16.25 \text{ m}$$

$$MAX = 19.25 \text{ m}$$

Por tanto, se confirma que la distancia escogida cumple los reglamentos.

4 COMPARTIMENTADO TRANSVERSAL.

4.1 Doble casco.

Este apartado definirá fundamentalmente las dimensiones de nuestro doble casco, que es medida exigida por el convenio MARPOL y por todas las Sociedades de Clasificación.

El MARPOL (Regla 13F, Anexo I: Reglas para prevenir la contaminación por hidrocarburos) plantea una manga mínima de doble casco en función del tonelaje de peso muerto. La formulación propuesta es la siguiente:

$$w = 0,5 + \frac{DW}{20\,000} \text{ (m) o bien}$$

$$w = 2,0 \text{ m, si este valor es menor.}$$

Por tanto, en nuestro caso, la manga mínima será la menor de las siguientes:

$$MIN1 = 15.5 \text{ m}$$

$$MIN2 = 2 \text{ m}$$

Utilizaremos un valor de doble caso de 3 metros por tomar un valor mayor al mínimo y así facilitar el acceso a estos tanques en caso de ser necesario acceder a ellos.

Cabe destacar que este doble casco lo utilizaremos como tanques de lastre, unidos a los espacios del doble fondo que se verá en el siguiente apartado, formando unos tanques de lastre en forma de "L", muy comunes en este tipo de buques.

4.2 Mamparos principales y de colisión.

Como tenemos 5 filas de tanques a lo largo de la eslora, habrá 6 mamparos principales situados entre tanque y tanque, un primero que dividirá la cámara de máquinas del primer tanque y un último que será el mamparo de colisión, que a su vez divide el tanque número 6 del pique de proa.

Mamparo	Posición longitudinal (desde perpendicular de popa)	Cuaderna (desde espejo de popa)
1°	67 m	Cuaderna nº105 (75,9 m)
2°	114 m	Cuaderna nº152 (122,9 m)
3°	161 m	Cuaderna nº199 (169,9 m)
4°	208 m	Cuaderna nº246 (216,9 m)
5°	255 m	Cuaderna nº293 (263,9 m)
6°	307 m	Cuaderna nº340 (315,9 m)

5 COMPARTIMENTADO VERTICAL.

5.1 Justificación de la altura de doble fondo.

Igual que para el caso del doble casco es obligatorio según el convenio MARPOL (Regla 13F, Anexo I: Reglas para prevenir la contaminación por hidrocarburos) establecer un doble fondo.

El convenio determina una altura mínima que se rige por la siguiente tabla:

$$h = B/15 \text{ (m) o bien}$$

$$h = 2,0 \text{ m, si este valor es menor.}$$

El valor mínimo de h será de 1,0 m.

Por tanto, para nuestro buque, la altura mínima de nuestro doble fondo será la menor de las siguientes:

$$MIN1 = 4 \text{ m}$$

$$MIN2 = 2 \text{ m}$$

Escogeremos un valor de doble fondo de 3,5 m basándonos en nuestro buque de referencia.

Como se ha dicho en el apartado anterior, este espacio pertenecerá a los tanques de lastre en forma de L, de la forma que se ve en la siguiente imagen.

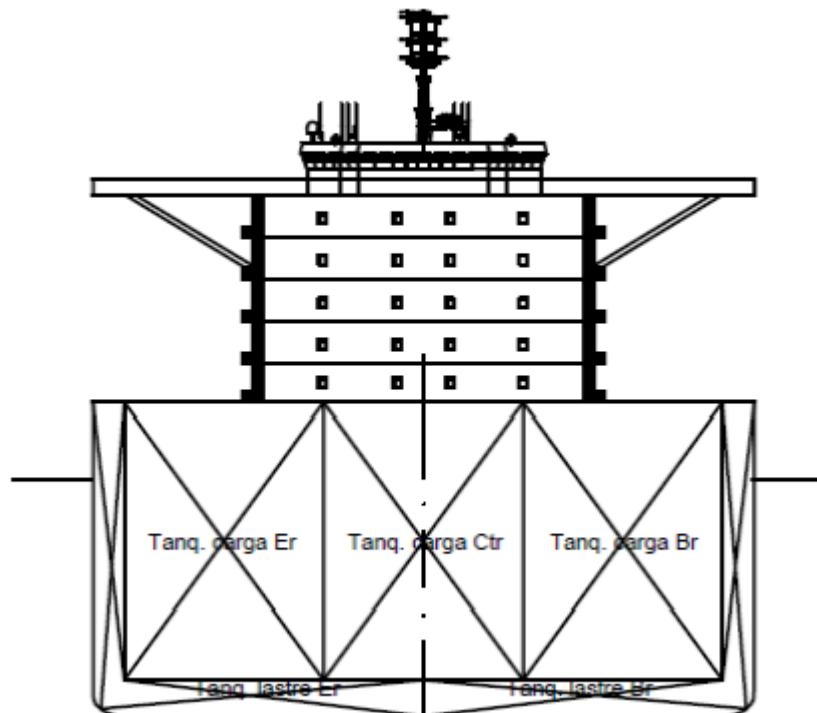

5.2 Mamparos longitudinales.

Como hemos visto en el apartado anterior, el compartimentado exige la colocación de dos mamparos longitudinales a lo largo del buque y ambos se colocarán en la línea que separa los tanques centrales de los de babor o estribor.

En nuestro caso, se han diseñado los tanques para que el central, que es simétrico respecto a crujía, tenga 18 metros de manga, es decir, a $y=9$ m e $y=-9$ m se colocarán los dos mamparos longitudinales, dejando a los tanques laterales una manga en el cuerpo central del buque de otros 18 metros.

6 DIMENSIONADO Y NÚMERO DE TANQUES.

6.1 Tanques del sistema de combustible.

El volumen de los tanques de combustible deberá ser suficiente para abastecer el motor durante las 18.000 millas para las que está diseñado el buque, a una velocidad de servicio de 14.8 nudos, por tanto, debemos saber primero el consumo del motor.

Cabe destacar que en este proyecto se diseña el buque para que pueda navegar con fuelóleo pesado (HFO) y gas natural licuado (LNG). Se calculará el dimensionado de tanques de fuelóleo pesado para hacer la totalidad del trayecto y luego se calcularán los tanques de gas para dar la autonomía de margen para puertos y para el paso del estrecho de Malaca, de aproximadamente 930 km.

A continuación, ponemos las características del motor elegido en el cuaderno VI:

MAN B&W G95ME-C10.5

Tier II

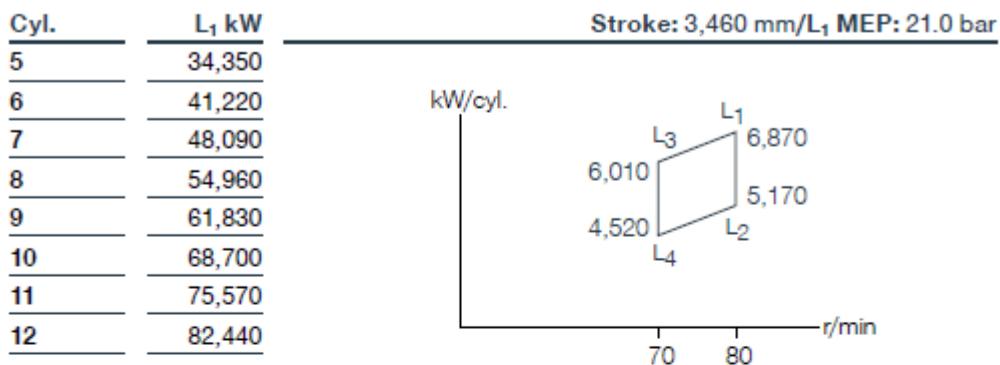

Fuel oil

MAN B&W G95ME-C10.5

L ₁ SFOC [g/kWh]			
Opt. load range	50%	75%	100%
High-load	159.5	158.5	163.0
Part-load EPT	157.5	157.0	165.5
Low-load EPT	155.5	158.0	165.5

GI (Methane)

MAN B&W G95ME-C10.5-GI

L ₁ dual fuel mode (SGC+SPOC)/fuel oil mode (SFOC) [g/kWh]			
Opt. load range	50%	75%	100%
High-load	129.5+3.9/159.5	129.5+2.9/161.0	136.3+2.4/168.0

Note: Also available for GIE and LGIP, see page 12.

6.1.1 Tanques de fuelóleo pesado (HFO).

Para calcular la dimensión de los tanques de fuelóleo pesado debemos ir al apartado de "fuel oil mode (SFOC)", donde el acrónimo "SFOC" significa "Specific Fuel Oil Consumption".

Como ya se ha dicho, dimensionaremos dichos tanques para cumplir la totalidad de la autonomía (18.000 millas). Vemos que al 100% consumirá 168 g/kWh, valor que podemos asumir correcto puesto que nuestro motor nunca va a trabajar al 100%, sino que se diseñó para trabajar al 85% de su capacidad.

La potencia del motor a la velocidad de servicio será de 39.930,71 kW según lo calculado en el cuaderno 6, y la densidad del combustible la tomaremos como 0.94 ton/m³.

Teniendo en cuenta esto, el consumo será:

$$\text{Consumo} = \frac{\text{Cep} * \text{BHPs} * \text{Autonomía}}{V_s * 10^6}$$

$$\text{Consumo} = \frac{168 * 39.930,71 * 18.000}{14,8 * 10^6}$$

$$\text{Consumo} = 8.158,82 \text{ ton}$$

Por tanto, el volumen total de tanques de combustible necesario será:

$$Vol = \frac{\text{Consumo}}{\text{Densidad del combustible}} = \frac{8.158,82}{0,94} = 8679,59 \text{ m}^3$$

$$\text{Vol} = \mathbf{8.680 \text{ m}^3}$$

Este volumen se dividirá entre los tanques de almacén, sedimentación y tanque de uso diario. Por lo que cada tanque tendrá como mínimo una capacidad de 4.340 m³.

- Tanques de uso diario:

Según el SOLAS, se debe disponer de dos tanques de uso diario que garanticen su servicio durante al menos 8 horas cada uno. Por tanto, debe tener un volumen de:

$$V_{\text{uso diario}} = \frac{\text{Cep} * \text{BHPs} * 8h}{10^6 * \text{densidad}} = \frac{168 * 39.930,71 * 8h}{10^6 * 0,94} = 57,09 \text{ m}^3$$

$$\text{V}_{\text{uso diario}} = \mathbf{58 \text{ m}^3}$$

Se dispondrán entonces dos tanques de uso diario de 58 m³ cada uno.

- Tanques de sedimentación:

En este tanque se produce la sedimentación de los elementos más pesados del fuelóleo, a partir de los cuales el combustible pasa al tanque de combustible diario. Para el cálculo del volumen se necesita un funcionamiento de los mismos de 24 horas.

$$V_{\text{sedimentación}} = \frac{\text{Cep} * \text{BHPs} * 36h}{10^6 * \text{densidad}} = \frac{168 * 39.930,71 * 24h}{10^6 * 0,94} = 171,28 \text{ m}^3$$

$$\text{V}_{\text{sedimentación}} = \mathbf{172 \text{ m}^3}$$

Por tanto, tendremos dos tanques de sedimentación de 86 m³ cada uno.

- Tanque almacén:

Este tanque se dispone para almacenar todo el fuel oil que no se encuentra en los dos calculados anteriormente, por tanto, su volumen será:

$$V_{\text{almacén}} = Vol - V_{\text{uso diario}} - V_{\text{sedimentación}}$$

$$V_{\text{almacén}} = 8.680 - 116 - 172 = 8.392 \text{ m}^3$$

$$\text{V}_{\text{almacén}} = \mathbf{8.392 \text{ m}^3}$$

Existirán dos tanques de almacén, si les sumamos el consumo de HFO de “pilot fuel” calculado en el apartado siguiente tenemos un total de 8.392 m², por lo que cada tanque dispondrá como mínimo de 4.196 m³.

6.1.2 Tanques de gas natural licuado (LNG).

Como ya se dijo al principio de este apartado, el 10% de llegada a puerto y el tramo del estrecho de Malaca se hará en el modo combinado de HFO y LNG.

Para este caso, deberemos ir a la tabla al apartado de “dual fuel mode (SGC+SPOC)”, donde el acrónimo “SGC” significa “Specific Gas Consumption”. En este modo, en el caso de carga de motor al 100%, se consumen según la tabla 136,3+2,4 g/kWh. El primer término representa el consumo de gas (136,3 g/kWh) y el segundo representa la mezcla denominada “pilot fuel” necesaria para que el motor funcione en este modo (2,4 g/kWh). Por tanto, se deberán calcular los consumos necesarios de ambos combustibles.

Sin embargo, deberemos calcular la distancia que supone un 10% de margen de llegada a puerto y la longitud del estrecho de Malaca. Resulta que la longitud máxima del estrecho de Malaca es de 578 millas (930 km), y el 10% de nuestra autonomía son 180 millas (290 km). Por tanto, la distancia total que debe abastecer el motor en modo combinado es de 758 millas (1220 km).

Procedemos entonces al cálculo de consumos:

- Consumo de LNG:

Es dato necesario para este apartado la densidad aproximada del LNG, que ronda los 450 kg/m³ (0,45 ton/m³).

$$\text{Consumo} = \frac{\text{Cep} * \text{BHPs} * \text{Autonomía}}{V_s * 10^6}$$

$$\text{Consumo} = \frac{136,3 * 39.930,71 * 758}{14,8 * 10^6}$$

$$\text{Consumo} = 278,75 \text{ ton}$$

Por tanto, el volumen de tanques de combustible necesario será:

$$\text{Vol} = \frac{\text{Consumo}}{\text{Densidad del combustible}} = \frac{278,75}{0,45} = 619,4 \text{ m}^3$$

$$\text{Vol} = 620 \text{ m}^3$$

Cabe destacar en este punto, como se realizará el dimensionamiento de los tanques de LNG. Se dividirán en dos tanques sobre cubierta de forma cilíndrica, lo cual es una disposición habitual en este tipo de buques. El volumen mínimo requerido por tanque será entonces de 317 m³, por tanto se decide poner un tanque a cada banda de radio igual a 2,5 metros y longitud de 18 metros, suponiendo un volumen real por tanque de 353,43 m³, lo cual sobrepasa el mínimo requerido y por tanto es válido.

- Consumo de HFO:

$$\text{Consumo} = \frac{\text{Cep} * \text{BHPs} * \text{Autonomía}}{V_s * 10^6}$$

$$\text{Consumo} = \frac{2,4 * 39.930,71 * 758}{14,8 * 10^6}$$

$$\text{Consumo} = 4,908 \text{ ton}$$

Por tanto, el volumen de tanques de combustible necesario será:

$$Vol = \frac{Consumo}{Densidad\ del\ combustible} = \frac{4,908}{0,94} = 5,221\ m^3$$

$$Vol = 6\ m^3$$

6.1.3 Resumen de resultados y tanques de combustible.

Hechos todos los cálculos, deberemos sumar el volumen de combustible HFO necesario al tanque de almacén del apartado 7.1.1. Se recoge todo lo calculado en lo que respecta a los tanques de combustible en la tabla siguiente:

TANQUES	VOLUMEN (m ³)	DIMENSIONAMIENTO (Longitud*Ancho*Altura)	V _{REQUERIDO} < V _{REAL}
Uso diario	116	2 tanques de 4x4x4 (128 m ³)	Cumple!
Sedimentación	172	2 tanques de 3x3x10 (180 m ³)	Cumple!
Almacén	8.392+6 → 8.398	2 tanques de 25x12x15 (9.000 m ³)	Cumple!
HFO	8.392+6 → 8.398	128+180+9.000=9.308 m ³	Cumple!
LNG*	620	2 tanques de $\pi*r^2*L =$ $=\pi*2,5^2*18$ (706,89 m ³)	Cumple!

*Mirar apartado 7.6, donde se regula al detalle todo lo relacionado con el sistema LNG.

6.2 Tanques de agua dulce.

El tanque de agua dulce se dimensiona en el “Cuaderno 12: Equipos y servicios”, por tanto, aquí ponemos lo calculado en dicho cuaderno.

Para potabilizar el agua existen distintos métodos como por evaporación, mediante ósmosis inversa, entre otras. Cuando se calculen las necesidades de agua potable, se seguirán las normas UNE-EN ISO 15748-1 y UNE-EN ISO 15748-2.

Para una primera estimación de consumo de agua se emplea la siguiente expresión:

$$Cantidad\ de\ agua = N \times días_{navegación} \times \frac{consumo\ de\ agua}{tripulante \times día}$$

Donde:

N: número de tripulantes (30).

El número de días vienen dados por la autonomía de 18.000 millas a 14,8 nudos:

$$\frac{18.000\ millas}{14,8\ nudos \times 24h} = 50,67 \sim 51\ días$$

El consumo de agua de tripulante por día es de 150 l/persona por día.

Por tanto:

$$\text{Cantidad de agua} = 30 \times 150 \times 51 = 229.500 \text{ litros} = 230 \text{ ton}$$

Se añade un margen del 10%:

$$\text{Cantidad de agua} = 230 \times 1,1 = 253 \text{ ton}$$

Tabla A.2

Valores guía del consumo de agua en diferentes puntos de servicio por persona y día para buques de carga

Punto de servicio	Consumo por cada utilización 1	Frecuencia de uso por día	Consumo		
			Cantidad total de agua l/día	Agua fría l/día	Agua caliente ^a l/día
Lavabo de pared o pedestal	2	6 ×	12	5	7
Plato de ducha	60	2 ×	120	50	70
Retrete de gravedad ^b	10	6 ×	60	60	–
Retrete de vacío ^b	1,2	6 ×	8	8	–
Urinario ^b	3	5 ×	15 ^c	15 ^c	–
Zona de cocina	–	–	20	8	12
Lavandería ^b	–	–	38	15 ^d	23
Limpieza	–	–	5	2	3

^a Temperatura de 60 °C en la admisión de agua caliente.
^b Si se utiliza agua no potable se reduce el consumo de agua potable proporcionalmente.
^c El uso de urinarios reduce la utilización de retretes.
^d Consumo de los aparatos con conexiones al agua caliente.

Puntos de servicio	Consumo (l/día*persona)		
	agua total	agua fría	agua caliente
Lavabo de pared	12	5	7
Plato de ducha	120	50	70
Retrete de gravedad	60	60	
Zona de cocina	20	8	12
Lavandería	38	15	23
Limpieza	5	2	3
TOTAL	255	140	115

Autonomía	51	días
Personas a bordo	30	Personas

	agua total	agua fría	agua caliente
Consumo medio diario (l/día)	7650	4200	3450
TOTAL (litros)	390150	214200	175950

Así pues, según la tabla del cuaderno 12, se estima un consumo de agua dulce por día igual a 7.650 litros, lo cual es un consumo total a final de trayecto (51 días) de 390.150 litros, es decir, un total de 390,15 m³ de agua como mínimo.

Vemos que el valor dista bastante de la primera aproximación, por tanto, debemos dimensionar el tanque de agua dulce para este valor.

Dicho esto, dispondremos de un tanque de agua dulce de dimensiones 5x16x5, lo cual implica un volumen real de tanque de 400 m³.

$$V_{\text{Tanque de Agua Dulce}} = 400 \text{ m}^3$$

6.3 Tanques de aceite.

Existirán dos tanques de aceite, uno para el motor y otro para reserva que será del mismo tamaño. Así pues, tenemos:

- Peso de aceite: 4% Peso de HFO.

$$Peso_{\text{aceite}} = 4\% \times Peso_{\text{HFO}} = 0,04 \times (9.308 \times 0,94)$$

$$Peso_{\text{aceite}} = 349,84 \text{ ton}$$

- Densidad del aceite: 0.92 ton/m³.

Por tanto, el volumen del aceite será:

$$V_{\text{aceite}} = \frac{\text{Peso de aceite}}{\text{Densidad del aceite}} = \frac{349,84}{0,92} = 380,26 \text{ m}^3$$

Como ya hemos dicho, habrá dos tanques, el del aceite y el de reserva, por tanto, el volumen total de aceite será:

$$V_{\text{TOTAL DE ACEITE}} = 760,52 \text{ m}^3$$

Dispondremos entonces de dos tanques de aceite de una capacidad de cómo mínimo 380,26 m³ cada uno. En este caso, se eligen dos tanques de dimensiones 7x7x8 m, lo cual nos facilita una capacidad de 392 m³, por tanto, al igual que en los tanques de agua dulce, estamos de nuevo del lado de la seguridad.

6.4 Tanques de aguas aceitosas y lodos.

Según el reglamento MARPOL:

“Todos los buques cuyo arqueado bruto sea igual o superior a 400 toneladas tendrán un tanque o tanques de capacidad suficiente, teniendo en cuenta el tipo de maquinaria con que estén equipados y la duración de sus viajes, para recibir los residuos (fangos) que no sea posible eliminar de otro modo cumpliendo las prescripciones del presente anexo, tales como los resultantes de la purificación de los combustibles y aceites lubricantes y de las fugas de hidrocarburos que se producen en los espacios de máquinas”.

El volumen de este tanque según la misma regla será el de la primera situación (Regla 17-1):

Respecto de los buques que no lleven agua de lastre en los tanques de combustible líquido, la capacidad mínima del tanque de fangos V1 será calculada conforme a la fórmula siguiente:

$$V_{\text{TANQUE DE LODOS}} = K_1 \times C \times D \text{ (m}^3\text{)}$$

Donde:

K₁: 0,01 (para buques en los que se purifique fueloil pesado destinado a la maquinaria principal).

C: consumo de fueloil diario en toneladas métricas ($116,72 \text{ m}^3 \times 0,94 = 109,72 \text{ ton}$).

D: período máximo de travesía (51 días).

Por tanto:

$$V_{\text{TANQUE DE LODOS}} = 0,01 \times 109,72 \times 51 \text{ (m}^3\text{)}$$

$$V_{\text{TANQUE DE LODOS}} = 55,96 \text{ m}^3$$

$$V_{\text{TANQUE DE LODO}} = 55,96 \text{ m}^3 \sim 56 \text{ m}^3$$

Este tanque se situará en el doble fondo de la cámara de máquinas. Será un único tanque y sus dimensiones serán de $4 \times 5 \times 3,5$, ocupando la altura total de doble fondo en la parte que le comprende. La capacidad total nuevamente será de 70 m^3 y por tanto volvemos a estar del lado de la seguridad.

6.5 Comprobación de la regla 12A del MARPOL en lo aplicable.

En primer lugar, debemos hacer la comprobación de la altura del doble fondo según la siguiente expresión:

$$h = \frac{B}{20} \text{ (mínimo: } 0,76 \text{ m} - \text{máximo: } 2 \text{ m)}$$

$$h = \frac{60}{20} = 3 \text{ m} \rightarrow 3 \text{ m} > 2 \text{ m} \rightarrow \mathbf{h = 2 \text{ m}}$$

A continuación, necesitaremos saber cuál es el volumen máximo disponible en nuestro buque de combustible (HFO). Dicho esto, si nos fijamos en el apartado 7.1.3 de este cuaderno, nos damos cuenta de que el combustible máximo disponible en el buque será el de los tanques y no el necesario calculado (el volumen de los tanques está un poco por encima de los calculados a lo largo del cuaderno). Dicho esto, el volumen de combustible total de HFO que se tendrá en el buque será la suma de los volúmenes de todos los tanques:

$$V_{\text{TOTAL DE TANQUES}} = 128 + 180 + 9.000 = 9.308 \text{ m}^3$$

Visto esto, nuestro buque se encuentra en el caso de buques de $V \geq 5.000 \text{ m}^3$, por tanto, se aplica según el MARPOL la siguiente formulación:

$$W = 0,5 + \frac{C}{20000} \text{ (mínimo: } 1 \text{ m} - \text{máximo: } 2 \text{ m)}$$

Donde:

W: separación de costado de tanques (m).

C: volumen total de fuel, en m^3 y al 98% de llenado.

Por tanto:

$$C = 0,98 \times 9.308 = 9.121,81 \text{ m}^3$$

$$W = 0,5 + \frac{9.121,81}{20000} = 0,456 \text{ m}$$

Como el mínimo para este caso es de 1 metro:

$$0,456 < 1 \rightarrow \mathbf{W = 1 \text{ m}}$$

Según la regla 12A del MARPOL, nuestra altura de doble fondo será como mínimo de 2 metros y nuestra separación de costado será como mínimo de 1 metro para los tanques de combustible. A continuación, se muestra una imagen explicativa del caso en que nos encontramos:

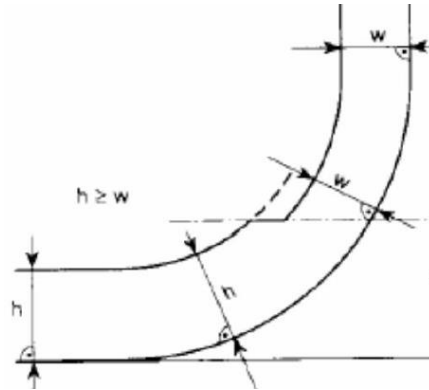

Como nuestro doble fondo ya se ha decidido que será de 3,5 metros, y nuestra separación de costado será de 3 metros. A priori, sin tener en cuenta que necesitemos o no más espacio a lo largo del cuaderno, podemos decir que con las dimensiones escogidas hasta el momento cumplimos de sobra los límites establecidos por la regla 12A del MARPOL.

6.6 Código IGF para tanques de LNG.

Para establecer tanto la posición como la instalación de gas del buque debemos recurrir al código IGF (*The International Code of Safety for Ships using Gases or other Low-flashpoint Fuels*). En esta etapa del proyecto se hará hincapié en la parte A-1 del mismo (*Specific requirements for ships using natural gas as fuel*), concretamente en el apartado 5 del código (Ship design and arrangement). En él se hará referencia fundamentalmente al diseño y disposición de los tanques de gas que situaremos en el petrolero, sin atender tanto al sistema de gas y a sus particularidades técnicas, que no son objeto de este cuaderno ni del proyecto.

El objetivo principal de este apartado es proporcionar una ubicación segura y una disposición adecuada para la protección de los tanques y los sistemas de almacenamiento de combustible (LNG).

Entre las regulaciones generales más importantes destacan:

- Los tanques de almacenamiento de combustible estarán protegidos contra daños mecánicos.
- Los tanques de almacenamiento de combustible y / o el equipo ubicado en cubierta abierta deberán ubicarse de manera que se asegure una ventilación natural suficiente, a fin de evitar la acumulación de escape de gas.
- El (los) tanque (s) de combustible estarán protegidos contra daños externos causados por colisión o puesta a tierra de la siguiente manera:
 1. Los tanques de combustible estarán situados a una distancia mínima de $B/5$ u 11,5 m, la que sea menor, medida hacia el interior desde el costado del buque en ángulo recto con el eje al nivel del calado de la línea de carga de verano. En nuestro caso:

$$\min\left(\frac{B}{5}; 11,5\right) = \min\left(\frac{60}{5}; 11,5\right) = 11,5 \text{ m}$$

2. Los límites de cada tanque de combustible se tomarán como los límites exteriores, longitudinales, transversales y verticales extremos de la estructura del tanque, incluidas sus válvulas.
3. Para los tanques independientes, la distancia de protección se medirá hasta la carcasa del tanque (la barrera principal del sistema de contención del tanque). En el caso de los tanques de membrana, se medirá la distancia a los mamparos que rodean el aislamiento del tanque.

4. En ningún caso el límite del tanque de combustible estará ubicado más cerca del forro exterior o de la perpendicular de popa del buque que de la siguiente manera:

For cargo ships:

- .1 for V_c below or equal 1,000 m³, 0.8 m;
- .2 for $1,000 \text{ m}^3 < V_c < 5,000 \text{ m}^3$, $0.75 + V_c \times 0.2/4,000$ m;
- .3 for $5,000 \text{ m}^3 \leq V_c < 30,000 \text{ m}^3$, $0.8 + V_c/25,000$ m; and
- .4 for $V_c \geq 30,000 \text{ m}^3$, 2 m,

where:

V_c corresponds to 100% of the gross design volume of the individual fuel tank at 20°C, including domes and appendages.

En nuestro caso, nuestro volumen total de gas a bordo es de 343 m³. Como tendremos un tanque a cada costado, tendremos dos tanques de 172 m³. Por tanto, estamos en el caso 1 ($V_c < 1.000 \text{ m}^3$) y nuestra distancia mínima de tanque al costado será de 0,8 metros.

5. El límite más bajo del (de los) tanque (s) de combustible se ubicará por encima de la distancia mínima de $B/15$ o 2,0 m, la que sea menor, medida desde la línea de trazado del revestimiento de la carcasa inferior en la línea central.

$$\min\left(\frac{B}{15}, 2\right) = \min\left(\frac{60}{15}; 2\right) = 2 \text{ m}$$

6. Para los buques multicasco, el valor de B puede ser considerado especialmente.
7. El (los) tanque (s) de combustible estarán a popa de un plano transversal a 0,08 L medido desde la perpendicular de proa de conformidad con la regla II-1 / 8.1 del Convenio SOLAS para buques de pasaje, y a popa del mamparo de colisión para buques de carga.

Donde:

L: la longitud definida en el Convenio internacional sobre líneas de carga (consulte la regla II-1 / 2.5 del Convenio SOLAS). En nuestro caso, dado la fase de diseño en la que nos encontramos utilizaremos la eslora entre perpendiculares de 325 metros, por tanto, los tanques se situarán según la norma, como mínimo 26 metros a popa del mamparo de colisión.

8. En el caso de los buques con una estructura de casco que ofrezca una mayor resistencia a colisiones y / o puesta a tierra, las reglamentaciones sobre la ubicación de los tanques de combustible pueden considerarse especialmente de conformidad con la sección 2.3.

Dicho esto, se situarán dos tanques de GNL a babor y estribor del barco, sobre la cubierta principal (30 metros), situados a 16 metros de la línea de crujía y sus dimensiones serán de tipo cilíndrico, con 2,5 metros de radio y 18 metros de longitud cada uno.

Con esta disposición se cumplen todas las exigencias establecidas por el código IGF de forma adecuada.

6.7 Comprobación de espacio para motor.

Es fundamental que una vez dispuestos todos los taques correspondientes a este cuaderno, se verifique que existe espacio suficiente para la colocación del motor. Ello ha sido una de las prioridades básicas durante la ejecución del mismo.

A continuación, se facilita el apartado de características geométricas correspondientes al catálogo de motores MAN respectivo a motores marinos:

Specifications

Dimensions:	A	B	C	H1	H4
mm	1,574	5,380	2,060	16,100	15,900

Cyl. distance	5-9 cyl.	10 cyl.	11 cyl.	12 cyl.
mm	1,574	1-6: 1,574	1-6: 1,574	1-6: 1,574
mm		7-10: 1,670	7-11: 1,670	7-12: 1,670

Cylinders:	5	6	7	8	9	10	11	12
L_{min} mm	11,468	13,042	14,616	16,190	17,804	19,779	21,489	23,159

Dry mass

Tier II	t	1,090	1,260	1,445	1,640	1,840	2,030	2,230	2,425
---------	---	-------	-------	-------	-------	-------	-------	-------	-------

Tier III (added)

EcoEGR	t	11	13	14	15	29	29	31	33
EGR	t	11	13	14	15	29	29	31	33
HP SCR	t	10	15	15	15				
LP SCR	t	-	-	-	-	-	-	-	-

Dual fuel (added)

GI	t	8	9	11	12	13	15	16	17
----	---	---	---	----	----	----	----	----	----

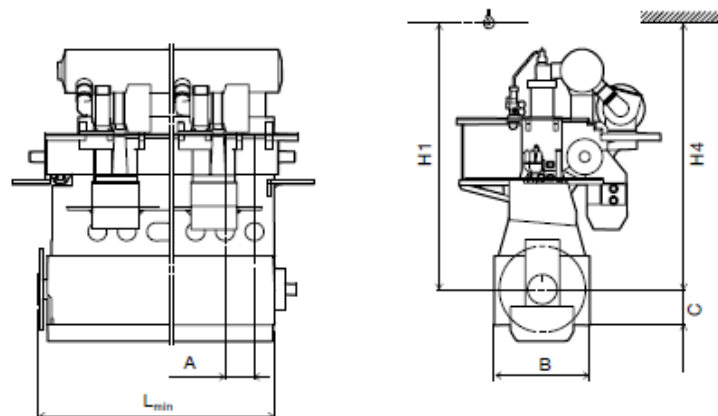

A modo de recordatorio, el modelo elegido de motor era el de 6 cilindros, pues aportaba la potencia más que suficiente para el correcto funcionamiento del buque.

Si nos ceñimos al catálogo, el motor tendrá unas dimensiones de 13,042 metros de longitud, por aproximadamente 10 metros de ancho y 17,96 metros de altura mínima libre por encima del mismo. Se puede comprobar que un motor de este calibre apoyado en el doble fondo de la cámara de máquinas encaja perfectamente y se sitúa convenientemente cerca de los tanques de combustible, tanto de HFO, como de GNL.

Cabe destacar en este apartado que, según lo que se verá en posteriores cuadernos, disponemos de tres cubiertas en cámara de máquinas, situadas las cubiertas N°1, N°2 y N°3 a 3,5, 13 y 24 metros sobre la línea de base. Esto implica que al apoyarse el motor sobre la

cubierta N°1, se dispondrá un hueco en la cubierta N°2 para que se respete la altura mínima libre por encima del mismo (se recomienda ver planos del cuaderno 7 para comprobar esto).

7 ZONA ESTANCA, PUNTOS DE INUNDACIÓN Y CÁLCULOS DE ARQUITECTURA NAVAL.

La zona estanca del buque se define como aquella que no tiene aberturas al exterior, es decir, se define como la zona a partir de la cual es imposible que entre agua en el buque sin un caso de avería.

En nuestro caso, la zona estanca del buque se extiende desde la línea de base a la cubierta principal, situada a 30 metros sobre la línea de base. Así pues, en este apartado veremos la zona estanca del buque de proyecto, así como los puntos de inundación progresiva.

Si medimos en los planos del cuaderno 7, vemos que existen cuatro puntos de inundación, dos a cada banda, los cuales corresponden con las entradas a la superestructura desde la cubierta principal. Dicho esto, la coordenada vertical será en cubierta, es decir, a 30 metros sobre la línea de base, las coordenadas longitudinales serán a 31,4 metros y a 53,3 metros desde la perpendicular de popa, y las coordenadas transversales, dado que la superestructura es simétrica respecto de crujía, serán de 18,5 metros y -18,5 metros tanto para los puntos más proa de la superestructura como los puntos más a popa. Por tanto, tendremos cuatro puntos de inundación progresiva, los cuales, junto con la zona estanca, se muestra a continuación:

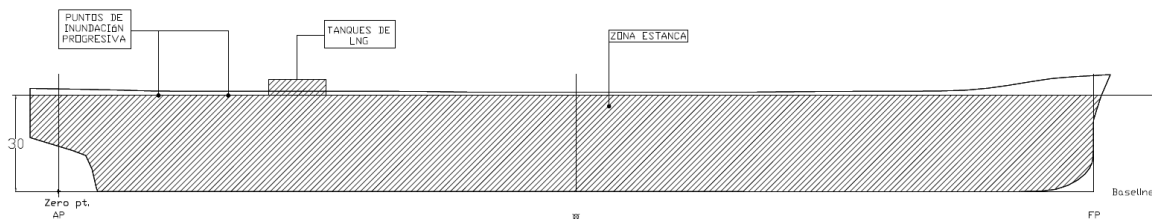

**Se recomienda ver los planos de los anexos para ver en más detalle y en formato A3.*

8 CALIBRADO DE LOS TANQUES.

Todos los tanques han sido diseñados en MAXSURF Stability para estar por encima de sus capacidades mínimas, las cuales han sido calculadas en los apartados anteriores (ver anexos de hipótesis de carga al 100%, donde se puede ver la carga máxima de cada uno de los tanques).

Además, en este apartado se debe decir que se han colocado los tanques de consumos de forma que el centro de gravedad de los mismos mantiene la coordenada transversal (manga) en el centro del buque. Es decir, aunque su emplazamiento final en el trabajo no coincida en ese punto, la idea es que no se aleje mucho del mismo y, para facilitar los cálculos en el programa hemos decidido colocarlos de forma simétrica.

En la página siguiente, se presenta la tabla con todos los tanques y sus capacidades.

TABLA DE CAPACIDADES DE LOS TANQUES

Item Name	Specific gravity	Quantity	Unit Mass tonne	Total Mass tonne	Unit Volume m^3	Total Volume m^3	Long. Arm m	Trans. Arm m	Vert. Arm m	Total FSM tonne.m	FSM Type
Lightship		1	0,000	0,000			318,000	0,000	0,000	0,000	User Specified
Pique de popa	Tank default (1,0250)	100%	1634,189	1634,189	1594,331	1594,331	-1,060	0,000	20,239	9534,681	Maximum
Pique de proa	Tank default (1,0250)	100%	7837,317	7837,317	7646,163	7646,163	313,178	0,000	13,941	34027,727	Maximum
Crude C1	Tank default (0,9500)	100%	20872,089	20872,089	21970,620	21970,620	90,500	0,000	16,750	21699,900	Maximum
Crude B1	Tank default (0,9500)	100%	16813,628	16813,628	17698,555	17698,555	92,391	-16,391	16,750	12665,768	Maximum
Crude E1	Tank default (0,9500)	100%	16813,628	16813,628	17698,555	17698,555	92,391	16,391	16,750	12665,768	Maximum
Crude C2	Tank default (0,9500)	100%	20872,089	20872,089	21970,620	21970,620	137,500	0,000	16,750	21699,900	Maximum
Crude B2	Tank default (0,9500)	100%	20872,089	20872,089	21970,620	21970,620	137,500	-18,000	16,750	21699,900	Maximum
Crude E2	Tank default (0,9500)	100%	20872,089	20872,089	21970,620	21970,620	137,500	18,000	16,750	21699,900	Maximum
Crude C3	Tank default (0,9500)	100%	20872,089	20872,089	21970,620	21970,620	184,500	0,000	16,750	21699,900	Maximum
Crude B3	Tank default (0,9500)	100%	20872,089	20872,089	21970,620	21970,620	184,500	-18,000	16,750	21699,900	Maximum
Crude E3	Tank default (0,9500)	100%	20872,089	20872,089	21970,620	21970,620	184,500	18,000	16,750	21699,900	Maximum
Crude C4	Tank default (0,9500)	100%	20872,089	20872,089	21970,620	21970,620	231,500	0,000	16,750	21699,900	Maximum
Crude B4	Tank default (0,9500)	100%	20872,089	20872,089	21970,620	21970,620	231,500	-18,000	16,750	21699,900	Maximum
Crude E4	Tank default (0,9500)	100%	20872,089	20872,089	21970,620	21970,620	231,500	18,000	16,750	21699,900	Maximum
Crude C5	Tank default (0,9500)	100%	23092,524	23092,524	24307,920	24307,920	281,000	0,000	16,750	24008,400	Maximum
Crude B5	Tank default (0,9500)	100%	15394,148	15394,148	16204,366	16204,366	276,665	-15,500	16,751	10550,383	Maximum
Crude E5	Tank default (0,9500)	100%	15394,148	15394,148	16204,366	16204,366	276,665	15,500	16,751	10550,383	Maximum
Lastre B1	Tank default (1,0250)	100%	12128,195	12128,195	11832,385	11832,385	88,514	-21,677	11,657	82588,066	Maximum
Lastre E1	Tank default (1,0250)	100%	12128,195	12128,195	11832,385	11832,385	88,514	21,677	11,657	82588,066	Maximum
Lastre B2	Tank default (1,0250)	100%	8591,238	8591,238	8381,696	8381,696	137,514	-20,719	8,319	106048,706	Maximum
Lastre E2	Tank default (1,0250)	100%	8591,238	8591,238	8381,696	8381,696	137,514	20,719	8,319	106048,706	Maximum
Lastre B3	Tank default (1,0250)	100%	8597,810	8597,810	8388,107	8388,107	184,500	-20,726	8,314	106389,007	Maximum
Lastre E3	Tank default (1,0250)	100%	8597,810	8597,810	8388,107	8388,107	184,500	20,726	8,314	106389,007	Maximum
Lastre B4	Tank default (1,0250)	100%	8455,954	8455,954	8249,711	8249,711	231,276	-20,589	8,371	100917,701	Maximum
Lastre E4	Tank default (1,0250)	100%	8455,954	8455,954	8249,711	8249,711	231,276	20,589	8,371	100917,701	Maximum
Lastre B5	Tank default (1,0250)	100%	11712,855	11712,855	11427,176	11427,176	280,652	-19,640	12,506	60275,844	Maximum
Lastre E5	Tank default (1,0250)	100%	11712,855	11712,855	11427,176	11427,176	280,652	19,640	12,506	60275,844	Maximum
Tanques LNG	Tank default (0,4500)	100%	353,544	353,544	785,654	785,654	75,002	0,000	32,500	23759,728	Maximum
HFO-USO DIARIO BABOR	Tank default (0,9400)	100%	58,957	58,957	62,720	62,720	44,000	-14,000	15,000	20,053	Maximum
HFO-USO DIARIO ESTRIBOR	Tank default (0,9400)	100%	58,957	58,957	62,720	62,720	44,000	14,000	15,000	20,053	Maximum
HFO Sedimentación Babor	Tank default (0,9400)	100%	82,908	82,908	88,200	88,200	47,500	-13,500	18,000	6,345	Maximum
HFO Sedimentación Estribor	Tank default (0,9400)	100%	82,908	82,908	88,200	88,200	47,500	13,500	18,000	6,345	Maximum
HFO Almacén Babor	Tank default (0,9400)	100%	4145,400	4145,400	4410,000	4410,000	44,500	-6,000	20,500	3384,000	Maximum

PETROLERO VLCC DE 300.000 TPM

CUADERNO IV: COMPARTIMENTADO Y CÁLCULOS DE ARQUITECTURA NAVAL

PEDRO LEMOS GONZÁLEZ

Item Name	Specific gravity	Quantity	Unit Mass tonne	Total Mass tonne	Unit Volume m ³	Total Volume m ³	Long. Arm m	Trans. Arm m	Vert. Arm m	Total FSM tonne.m	FSM Type
HFO Almacén Estribor	Tank default (0,9400)	100%	4145,400	4145,400	4410,000	4410,000	44,500	6,000	20,500	3384,000	Maximum
Tanques de AD	Tank default (1,0000)	100%	470,400	470,400	470,400	470,400	11,500	0,000	27,000	1706,667	Maximum
Tanque Aceite Babor	Tank default (0,9200)	100%	353,427	353,427	384,160	384,160	53,500	-15,500	17,000	184,077	Maximum
Tanque Aceite Estribor	Tank default (0,9200)	100%	353,427	353,427	384,160	384,160	53,500	15,500	17,000	184,077	Maximum
Aguas Aceitosas/Lodos	Tank default (1,0060)	100%	5,616	5,616	5,583	5,583	32,001	0,000	1,755	41,917	Maximum
Total Loadcase				414783,519	428770,410	428770,410	182,586	0,000	15,233	1276138,017	
FS correction									3,077		
VCG fluid									18,309		

9 ESPACIOS DE CARGA Y JUSTIFICACIÓN DE CUMPLIMIENTO DE LA RPA.

En este apartado se justificarán los espacios de carga generados en MAXSURF Stability con respecto a los objetivos establecidos en la RPA.

En este caso, el objetivo de la RPA no es de carga como en muchos otros buques, sino de peso muerto. El peso muerto del buque se define como la diferencia entre el desplazamiento y el peso en rosca del buque. Esto quiere decir que para su cálculo se tiene en cuenta el peso de la carga, de los consumos, de tripulación y pertrechos.

Empezamos este apartado comentando las dimensiones de nuestros tanques de carga. Los tanques tendrán la misma manga de 18 metros, a excepción de los de la primera fila y la última que, aunque parten de 18 metros de manga, ésta se reduce conforme nos aproximamos a los extremos del buque, pues las formas empiezan a ser más afiladas y, por tanto, los tanques deben adaptarse a las mismas respetando el margen de doble casco que ocuparán los tanques de lastre correspondiente.

Con respecto a la eslora, los tanques correspondientes a la 1ª, 2ª, 3ª y 4ª fila, tendrán una longitud de 47 metros, mientras que los de la 6ª fila tendrán una eslora de 52 metros. Ello viene por el hecho de que las formas de proa son las más afiladas del buque, entonces es mejor aprovechar más eslora a costa de ganar más espacio de carga.

Con respecto a la altura de los tanques, todos tienen el mismo puntal, van desde el doble fondo, situado a 3,5 metros de la línea base, a la cubierta principal, situada a 30 metros de la línea base. Así pues, el puntal de todos los tanques será de 26,5 metros. Dicho esto, procedemos a ver la masa total de tanques de carga que proporciona MAXSURF.

$$\text{Masa total de crudo} = 296.228,96 \text{ ton}$$

Por tanto, esta será la carga máxima de crudo que podrá transportar el petrolero del proyecto.

Con respecto a los consumos, se tienen en cuenta el peso de combustibles, aceite, agua dulce y víveres. Según MAXSURF, el peso total de estos apartados es de:

$$\text{Masa total de consumos} = 10.075,86 \text{ ton}$$

Con respecto a la tripulación, ya se calculó en el cuaderno 1 la masa de 30 tripulantes, considerando un peso por persona de 125 kg:

$$\text{Masa total tripulación} = 3,75 \text{ ton}$$

Los pertrechos también fueron calculados en el cuaderno 1:

$$\text{Masa total de pertrechos} = 80 \text{ ton}$$

Dicho esto, el peso muerto total del buque será la suma de lo anterior.

$$DWT_{MAXSURF} = 296.228,96 + 10.075,86 + 3,75 + 80$$

$$DWT_{MAXSURF} = 306.387,87 \text{ ton}$$

Nuestro parámetro de diseño en la RPA era diseñar un buque de 300.000 toneladas de peso muerto, por tanto, hemos cumplido con respecto a los objetivos iniciales del proyecto.

10 CÁLCULO DE LAS CURVAS HIDROSTÁTICAS.

Para el cálculo de las curvas hidrostáticas utilizaremos el programa MAXSURF Stability. Como ya hemos visto el compartimentado de los tanques de carga, lastre y consumos, lo que queda es el cálculo de curvas hidrostáticas para diferentes calados y trimados.

En cuanto a los calados, los hemos variado desde 2 m hasta 22,6 m, pues el calado máximo de flotación es de 22 m según nuestro modelo de MAXSURF, con un incremento entre los mismos de 0,2 m, resultando un número final de 104 calados diferentes.

Con respecto a los trimados, lo normal es escoger una variación de trimados de $\pm 1.5\%$ de la eslora entre perpendiculares del buque a analizar, en nuestro caso este porcentaje es de 4.875 m, que entre tres (número recomendable de trimados a popa y proa en el ámbito académico), nos da una variación de trimados de 1,625 m. Como los intervalos de asiento se recomienda que sean de número enteros, aplicaremos un intervalo de asiento de 1,6. Ello implica que nuestros trimados serán entre 0; $\pm 1,6$; $\pm 3,2$; y $\pm 4,8$.

• **Para un trimado de 0 metros:**

Draft Amidships m	Displacement t	Draft at LCF m	Trim (+ve by stern) m	WL Length m	Beam max extents on WL m	Wetted Area m ²	Waterpl. Area m ²	Block coeff. (Cb)	LCB from zero pt. (+ve fwd) m	LCF from zero pt. (+ve fwd) m	KB m	BMt m	BML m	KMt m	KML m	Immersion (TPc) tonne/cm	MTC tonne.m
2,000	28057	2,000	0,000	305,621	59,628	15012,257	14596,605	0,751	171,658	172,097	1,034	132,085	2932,087	133,118	2933,121	149,615	2513,157
2,200	31059	2,200	0,000	306,036	59,757	15177,111	14694,211	0,753	171,703	172,151	1,137	121,014	2682,785	122,151	2683,922	150,616	2543,937
2,400	34081	2,400	0,000	306,451	59,863	15338,113	14785,014	0,755	171,746	172,219	1,240	111,705	2474,732	112,945	2475,972	151,546	2573,384
2,600	37121	2,600	0,000	306,866	59,935	15495,706	14868,516	0,757	171,788	172,280	1,343	103,727	2298,451	105,070	2299,794	152,402	2601,678
2,800	40178	2,800	0,000	307,281	59,985	15651,240	14946,997	0,760	171,829	172,335	1,447	96,840	2147,129	98,287	2148,576	153,207	2628,971
3,000	43250	3,000	0,000	307,696	59,999	15801,920	15014,128	0,762	171,869	172,403	1,550	90,714	2014,742	92,264	2016,291	153,895	2653,927
3,200	46335	3,200	0,000	308,111	60,000	15950,776	15076,467	0,764	171,910	172,468	1,653	85,307	1898,664	86,960	1900,317	154,534	2677,900
3,400	49433	3,400	0,000	308,526	60,000	16098,057	15135,448	0,766	171,950	172,518	1,756	80,520	1795,921	82,277	1797,677	155,138	2700,825
3,600	52543	3,600	0,000	308,929	60,000	16243,992	15191,305	0,768	171,988	172,558	1,860	76,249	1704,329	78,109	1706,189	155,711	2722,823
3,800	55662	3,800	0,000	309,221	60,000	16388,292	15244,000	0,770	172,021	172,590	1,963	72,412	1622,083	74,375	1624,045	156,251	2743,802
4,000	58793	4,000	0,000	309,513	60,000	16530,914	15293,585	0,772	172,052	172,627	2,066	68,941	1547,738	71,007	1549,804	156,759	2763,799
4,200	61933	4,200	0,000	309,805	60,000	16672,614	15341,142	0,774	172,082	172,664	2,169	65,793	1480,330	67,962	1482,499	157,247	2783,157
4,400	65082	4,400	0,000	310,097	60,000	16813,338	15386,599	0,776	172,111	172,690	2,272	62,926	1418,819	65,199	1421,091	157,713	2801,729
4,600	68241	4,600	0,000	310,389	60,000	16953,697	15430,695	0,777	172,138	172,711	2,375	60,304	1362,628	62,680	1365,003	158,165	2819,949
4,800	71409	4,800	0,000	310,682	60,000	17093,150	15472,636	0,779	172,164	172,724	2,479	57,893	1310,880	60,371	1313,358	158,595	2837,379
5,000	74586	5,000	0,000	310,974	60,000	17231,965	15512,805	0,780	172,189	172,734	2,582	55,665	1263,150	58,247	1265,732	159,006	2854,288
5,200	77770	5,200	0,000	311,266	60,000	17369,899	15551,124	0,781	172,212	172,740	2,685	53,601	1218,913	56,286	1221,598	159,399	2870,547
5,400	80962	5,400	0,000	311,559	60,000	17506,693	15587,168	0,782	172,234	172,744	2,788	51,680	1177,688	54,468	1180,476	159,768	2885,935
5,600	84162	5,600	0,000	311,768	60,000	17642,403	15621,378	0,784	172,254	172,743	2,891	49,892	1139,178	52,783	1142,069	160,119	2900,527
5,800	87369	5,800	0,000	311,975	60,000	17777,719	15654,892	0,785	172,273	172,742	2,994	48,225	1103,338	51,220	1106,332	160,463	2914,970
6,000	90582	6,000	0,000	312,182	60,000	17912,737	15687,652	0,786	172,291	172,732	3,097	46,669	1069,867	49,766	1072,965	160,798	2929,190
6,200	93803	6,200	0,000	312,389	60,000	18047,673	15719,898	0,788	172,308	172,717	3,200	45,214	1038,545	48,414	1041,746	161,129	2943,225
6,400	97030	6,400	0,000	312,597	60,000	18182,478	15751,432	0,789	172,323	172,695	3,304	43,850	1009,135	47,153	1012,439	161,452	2956,987
6,600	100264	6,600	0,000	312,804	60,000	18317,290	15782,265	0,790	172,337	172,668	3,407	42,567	981,477	45,974	984,884	161,768	2970,526
6,800	103504	6,800	0,000	313,011	60,000	18452,074	15812,661	0,791	172,349	172,632	3,510	41,359	955,459	44,869	958,969	162,080	2983,993
7,000	106749	7,000	0,000	313,219	60,000	18586,582	15842,073	0,792	172,357	172,591	3,613	40,218	930,863	43,831	934,476	162,381	2997,095
7,200	109999	7,200	0,000	313,421	60,000	18720,521	15869,858	0,793	172,363	172,541	3,716	39,136	907,458	42,852	911,174	162,666	3009,491
7,400	113255	7,400	0,000	313,598	60,000	18854,019	15896,358	0,794	172,367	172,490	3,819	38,108	885,204	41,927	889,023	162,938	3021,385
7,600	116517	7,600	0,000	313,781	60,000	18987,197	15921,918	0,794	172,370	172,438	3,922	37,130	864,065	41,053	867,987	163,200	3032,977
7,800	119784	7,800	0,000	313,965	60,000	19120,373	15947,360	0,795	172,371	172,379	4,025	36,201	844,094	40,226	848,119	163,460	3044,784
8,000	123055	8,000	0,000	314,149	60,000	19253,482	15972,455	0,796	172,370	172,318	4,128	35,318	825,107	39,447	829,236	163,718	3056,454
8,200	126333	8,200	0,000	314,333	60,000	19386,586	15997,123	0,797	172,368	172,253	4,231	34,479	807,022	38,710	811,253	163,971	3067,948
8,400	129615	8,400	0,000	314,517	60,000	19519,992	16021,976	0,798	172,364	172,180	4,334	33,681	789,859	38,015	794,193	164,225	3079,616
8,600	132902	8,600	0,000	314,700	60,000	19653,612	16046,845	0,798	172,358	172,096	4,438	32,920	773,541	37,358	777,979	164,480	3091,417
8,800	136194	8,800	0,000	314,884	60,000	19787,376	16071,599	0,799	172,351	172,005	4,541	32,196	757,968	36,736	762,509	164,734	3103,171

PETROLERO VLCC DE 300.000 TPM

CUADERNO IV: COMPARTIMENTADO Y CÁLCULOS DE ARQUITECTURA NAVAL

PEDRO LEMOS GONZÁLEZ

Draft Amidships m	Displacement t	Draft at LCF m	Trim (+ve by stern) m	WL Length m	Beam max extents on WL m	Wetted Area m ²	Waterpl. Area m ²	Block coeff. (Cb)	LCB from zero pt. (+ve fwd) m	LCF from zero pt. (+ve fwd) m	KB m	BMt m	BML m	KMt m	KML m	Immersion (TPc) tonne/cm	MTc tonne.m
9,000	139492	9,000	0,000	315,027	60,000	19920,982	16095,554	0,800	172,341	171,905	4,644	31,503	742,987	36,147	747,631	164,979	3114,446
9,200	142794	9,200	0,000	315,155	60,000	20055,125	16120,103	0,801	172,330	171,798	4,747	30,843	728,766	35,589	733,513	165,231	3126,149
9,400	146102	9,400	0,000	315,283	60,000	20189,592	16144,838	0,802	172,317	171,685	4,850	30,210	715,208	35,060	720,058	165,485	3138,074
9,600	149414	9,600	0,000	315,411	60,000	20323,258	16170,383	0,802	172,302	171,563	4,953	29,606	702,359	34,559	707,312	165,746	3150,626
9,800	152732	9,800	0,000	315,540	60,000	20457,973	16195,775	0,803	172,284	171,437	5,056	29,026	690,036	34,083	695,092	166,007	3163,159
10,000	156055	10,000	0,000	315,668	60,000	20593,547	16222,052	0,804	172,264	171,300	5,159	28,471	678,347	33,631	683,507	166,276	3176,351
10,200	159383	10,200	0,000	315,796	60,000	20729,288	16248,164	0,805	172,242	171,161	5,263	27,937	667,120	33,200	672,382	166,544	3189,543
10,400	162717	10,400	0,000	315,924	60,000	20864,660	16272,826	0,805	172,219	171,028	5,366	27,419	656,221	32,785	661,587	166,796	3202,204
10,600	166056	10,600	0,000	316,052	60,000	21000,298	16297,339	0,806	172,193	170,888	5,469	26,920	645,731	32,389	651,200	167,048	3214,839
10,800	169399	10,800	0,000	316,155	60,000	21136,479	16322,559	0,807	172,166	170,733	5,572	26,440	635,744	32,013	641,317	167,306	3228,058
11,000	172749	11,000	0,000	316,257	60,000	21273,205	16348,593	0,807	172,136	170,569	5,676	25,979	626,243	31,655	631,918	167,573	3241,923
11,200	176103	11,200	0,000	316,358	60,000	21410,409	16375,005	0,808	172,104	170,400	5,779	25,535	617,132	31,314	622,911	167,844	3256,067
11,400	179463	11,400	0,000	316,832	60,000	21521,752	16401,520	0,808	172,071	170,230	5,882	25,108	608,353	30,990	614,236	168,116	3270,286
11,600	182828	11,600	0,000	317,373	60,000	21658,424	16428,456	0,807	172,035	170,055	5,986	24,696	599,941	30,682	605,926	168,392	3284,863
11,800	186199	11,800	0,000	317,914	60,000	21797,365	16457,821	0,807	171,997	169,855	6,089	24,299	592,151	30,388	598,240	168,693	3301,391
12,000	189576	12,000	0,000	318,456	60,000	21937,230	16488,016	0,807	171,957	169,646	6,193	23,916	584,733	30,109	590,926	169,002	3318,604
12,200	192959	12,200	0,000	318,997	60,000	22077,583	16518,766	0,806	171,915	169,430	6,297	23,545	577,632	29,842	583,929	169,317	3336,285
12,400	196349	12,400	0,000	319,538	60,000	22218,432	16550,264	0,806	171,870	169,206	6,400	23,188	570,857	29,588	577,258	169,640	3354,591
12,600	199745	12,600	0,000	320,079	60,000	22359,450	16581,662	0,805	171,822	168,981	6,504	22,842	564,283	29,346	570,787	169,962	3372,849
12,800	203147	12,800	0,000	320,618	60,000	22501,393	16611,555	0,805	171,773	168,765	6,608	22,506	557,747	29,114	564,354	170,268	3390,091
13,000	206556	13,000	0,000	321,276	60,000	22644,496	16643,499	0,804	171,721	168,524	6,712	22,179	551,718	28,891	558,430	170,596	3409,319
13,200	209971	13,200	0,000	321,941	60,000	22787,398	16674,910	0,803	171,667	168,288	6,816	21,861	545,825	28,677	552,641	170,918	3428,289
13,400	213393	13,400	0,000	322,605	60,000	22930,671	16706,413	0,803	171,611	168,050	6,920	21,552	540,134	28,472	547,054	171,241	3447,472
13,600	216821	13,600	0,000	323,270	60,000	23073,918	16737,687	0,802	171,553	167,814	7,024	21,253	534,586	28,277	541,610	171,561	3466,537
13,800	220255	13,800	0,000	323,935	60,000	23215,131	16766,153	0,801	171,493	167,606	7,128	20,962	528,846	28,090	535,974	171,853	3483,249
14,000	223696	14,000	0,000	324,600	60,000	23360,731	16799,395	0,800	171,431	167,350	7,232	20,681	523,865	27,913	531,097	172,194	3504,092
14,200	227143	14,200	0,000	325,265	60,000	23504,660	16830,706	0,800	171,368	167,114	7,336	20,408	518,786	27,744	526,122	172,515	3523,320
14,400	230597	14,400	0,000	325,930	60,000	23649,556	16862,852	0,799	171,302	166,869	7,441	20,142	513,948	27,583	521,389	172,844	3543,306
14,600	234057	14,600	0,000	326,595	60,000	23795,476	16895,893	0,798	171,235	166,615	7,545	19,885	509,351	27,430	516,896	173,183	3564,117
14,800	237524	14,800	0,000	327,260	60,000	23939,059	16925,971	0,797	171,165	166,388	7,650	19,633	504,553	27,282	512,203	173,491	3582,612
15,000	240997	15,000	0,000	333,947	60,000	24084,772	16957,238	0,782	171,095	166,145	7,754	19,384	500,112	27,138	507,866	173,812	3602,837
15,200	244476	15,200	0,000	333,948	60,000	24230,601	16987,965	0,783	171,023	165,903	7,859	19,140	495,776	26,998	503,634	174,127	3623,021
15,400	247962	15,400	0,000	333,949	60,000	24376,306	17018,106	0,784	170,949	165,665	7,963	18,901	491,511	26,864	499,475	174,436	3642,940
15,600	251454	15,600	0,000	333,949	60,000	24521,627	17047,503	0,785	170,874	165,432	8,068	18,668	487,289	26,736	495,357	174,737	3662,379
15,800	254951	15,800	0,000	333,949	60,000	24660,669	17069,917	0,786	170,798	165,269	8,173	18,441	482,387	26,613	490,560	174,967	3675,692
16,000	258454	16,000	0,000	333,949	60,000	24808,894	17101,676	0,787	170,721	165,012	8,277	18,219	478,685	26,497	486,963	175,292	3697,583
16,200	261963	16,200	0,000	333,949	60,000	24956,748	17132,941	0,787	170,643	164,760	8,382	18,003	475,023	26,385	483,406	175,613	3719,112
16,400	265478	16,400	0,000	333,949	60,000	25103,496	17162,853	0,788	170,564	164,521	8,487	17,792	471,308	26,280	479,796	175,919	3739,528

PETROLERO VLCC DE 300.000 TPM

CUADERNO IV: COMPARTIMENTADO Y CÁLCULOS DE ARQUITECTURA NAVAL

PEDRO LEMOS GONZÁLEZ

Draft Amidships m	Displacement t	Draft at LCF m	Trim (+ve by stern) m	WL Length m	Beam max extents on WL m	Wetted Area m ²	Waterpl. Area m ²	Block coeff. (Cb)	LCB from zero pt. (+ve fwd) m	LCF from zero pt. (+ve fwd) m	KB m	BMt m	BML m	KMt m	KML m	Immersion (TPc) tonne/cm	MTc tonne.m
16,600	268999	16,600	0,000	333,949	60,000	25249,195	17191,329	0,789	170,483	164,296	8,592	17,587	467,529	26,179	476,121	176,211	3758,717
16,800	272526	16,800	0,000	333,949	60,000	25389,535	17213,946	0,790	170,402	164,130	8,697	17,387	463,191	26,084	471,888	176,443	3772,493
17,000	276058	17,000	0,000	333,950	60,000	25536,801	17243,312	0,791	170,320	163,897	8,802	17,192	459,696	25,994	468,498	176,744	3792,594
17,200	279595	17,200	0,000	333,950	60,000	25681,723	17269,096	0,791	170,238	163,697	8,907	17,000	455,935	25,907	464,842	177,008	3809,738
17,400	283138	17,400	0,000	333,950	60,000	25825,420	17292,753	0,792	170,155	163,516	9,012	16,811	452,072	25,823	461,084	177,251	3825,276
17,600	286685	17,600	0,000	333,950	60,000	25968,224	17314,822	0,793	170,071	163,350	9,117	16,625	448,160	25,742	457,277	177,477	3839,616
17,800	290237	17,800	0,000	333,950	60,000	26110,546	17335,868	0,794	169,988	163,191	9,222	16,442	444,261	25,664	453,483	177,693	3853,303
18,000	293793	18,000	0,000	333,950	60,000	26252,572	17356,195	0,795	169,905	163,038	9,327	16,263	440,397	25,590	449,725	177,901	3866,537
18,200	297353	18,200	0,000	333,950	60,000	26394,254	17375,819	0,796	169,822	162,890	9,432	16,088	436,571	25,520	446,003	178,102	3879,340
18,400	300917	18,400	0,000	333,950	60,000	26535,631	17394,814	0,796	169,739	162,748	9,537	15,915	432,784	25,453	442,322	178,297	3891,750
18,600	304485	18,600	0,000	333,950	60,000	26676,724	17413,266	0,797	169,656	162,611	9,642	15,747	429,038	25,389	438,680	178,486	3903,776
18,800	308056	18,800	0,000	333,950	60,000	26817,570	17431,252	0,798	169,574	162,479	9,747	15,582	425,337	25,329	435,084	178,670	3915,484
19,000	311632	19,000	0,000	333,950	60,000	26958,186	17448,806	0,799	169,492	162,351	9,852	15,420	421,683	25,273	431,535	178,850	3926,896
19,200	315210	19,200	0,000	333,950	60,000	27098,600	17465,854	0,799	169,410	162,228	9,957	15,262	418,069	25,219	428,026	179,025	3937,957
19,400	318793	19,400	0,000	333,950	60,000	27238,825	17482,483	0,800	169,329	162,109	10,062	15,107	414,497	25,170	424,560	179,195	3948,707
19,600	322378	19,600	0,000	333,950	60,000	27378,920	17498,852	0,801	169,248	161,993	10,167	14,956	410,979	25,123	421,147	179,363	3959,269
19,800	325967	19,800	0,000	333,950	60,000	27518,851	17514,903	0,802	169,167	161,880	10,272	14,808	407,511	25,080	417,783	179,528	3969,612
20,000	329559	20,000	0,000	333,950	60,000	27658,629	17530,678	0,802	169,087	161,772	10,377	14,662	404,091	25,040	414,468	179,689	3979,742
20,200	333155	20,200	0,000	333,950	60,000	27798,321	17546,453	0,803	169,008	161,667	10,482	14,521	400,739	25,003	411,221	179,851	3989,870
20,400	336753	20,400	0,000	333,950	60,000	27937,947	17562,194	0,804	168,929	161,567	10,587	14,382	397,449	24,969	408,036	180,012	3999,970
20,600	340355	20,600	0,000	333,950	60,000	28077,484	17577,747	0,804	168,850	161,469	10,692	14,246	394,209	24,938	404,901	180,172	4009,919
20,800	343960	20,800	0,000	333,950	60,000	28217,060	17593,418	0,805	168,772	161,373	10,797	14,113	391,039	24,910	401,836	180,333	4019,954
21,000	347569	21,000	0,000	333,954	60,000	28356,560	17609,088	0,806	168,695	161,282	10,902	13,984	387,927	24,885	398,829	180,493	4029,968
21,200	351180	21,200	0,000	333,967	60,000	28493,455	17625,359	0,807	168,618	161,200	11,007	13,857	384,914	24,864	395,920	180,660	4040,413
21,400	354795	21,400	0,000	333,981	60,000	28633,107	17641,943	0,807	168,542	161,127	11,112	13,732	381,986	24,844	393,098	180,830	4051,189
21,600	358413	21,600	0,000	333,994	60,000	28772,813	17658,321	0,808	168,467	161,060	11,217	13,610	379,115	24,826	390,331	180,998	4061,995
21,800	362035	21,800	0,000	334,008	60,000	28912,435	17674,200	0,808	168,393	160,999	11,322	13,488	376,274	24,810	387,596	181,161	4072,567
22,000	365660	22,000	0,000	334,021	60,000	29051,939	17689,597	0,809	168,319	160,944	11,426	13,369	373,464	24,795	384,890	181,318	4082,904
22,200	369288	22,200	0,000	334,035	60,000	29191,465	17704,921	0,810	168,247	160,895	11,531	13,251	370,710	24,782	382,241	181,475	4093,310
22,400	372919	22,400	0,000	334,066	60,000	29330,901	17719,913	0,810	168,175	160,853	11,636	13,134	367,991	24,771	379,627	181,629	4103,563
22,600	376553	22,600	0,000	334,122	60,000	29470,283	17734,658	0,811	168,104	160,815	11,741	13,020	365,311	24,761	377,052	181,780	4113,716

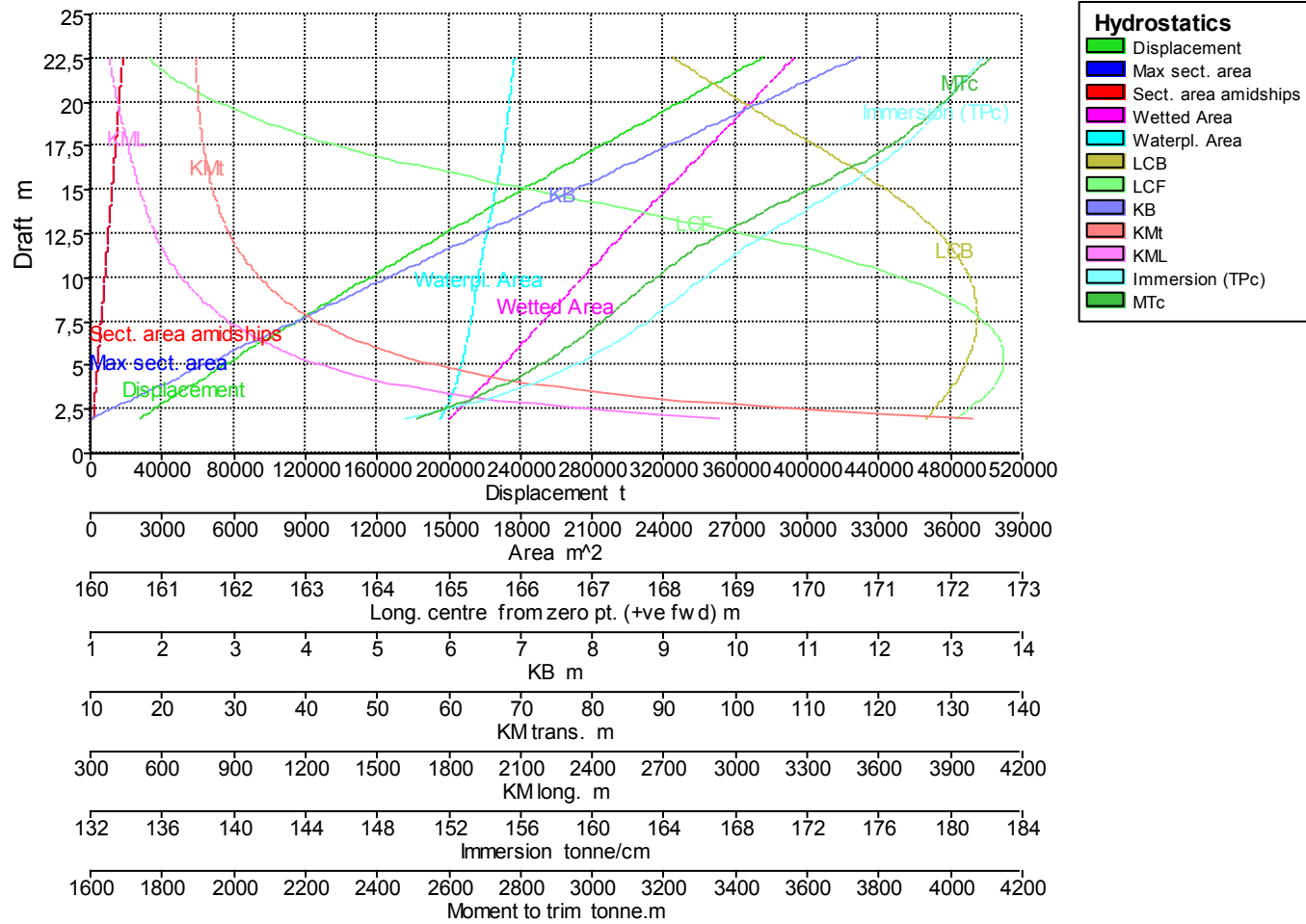

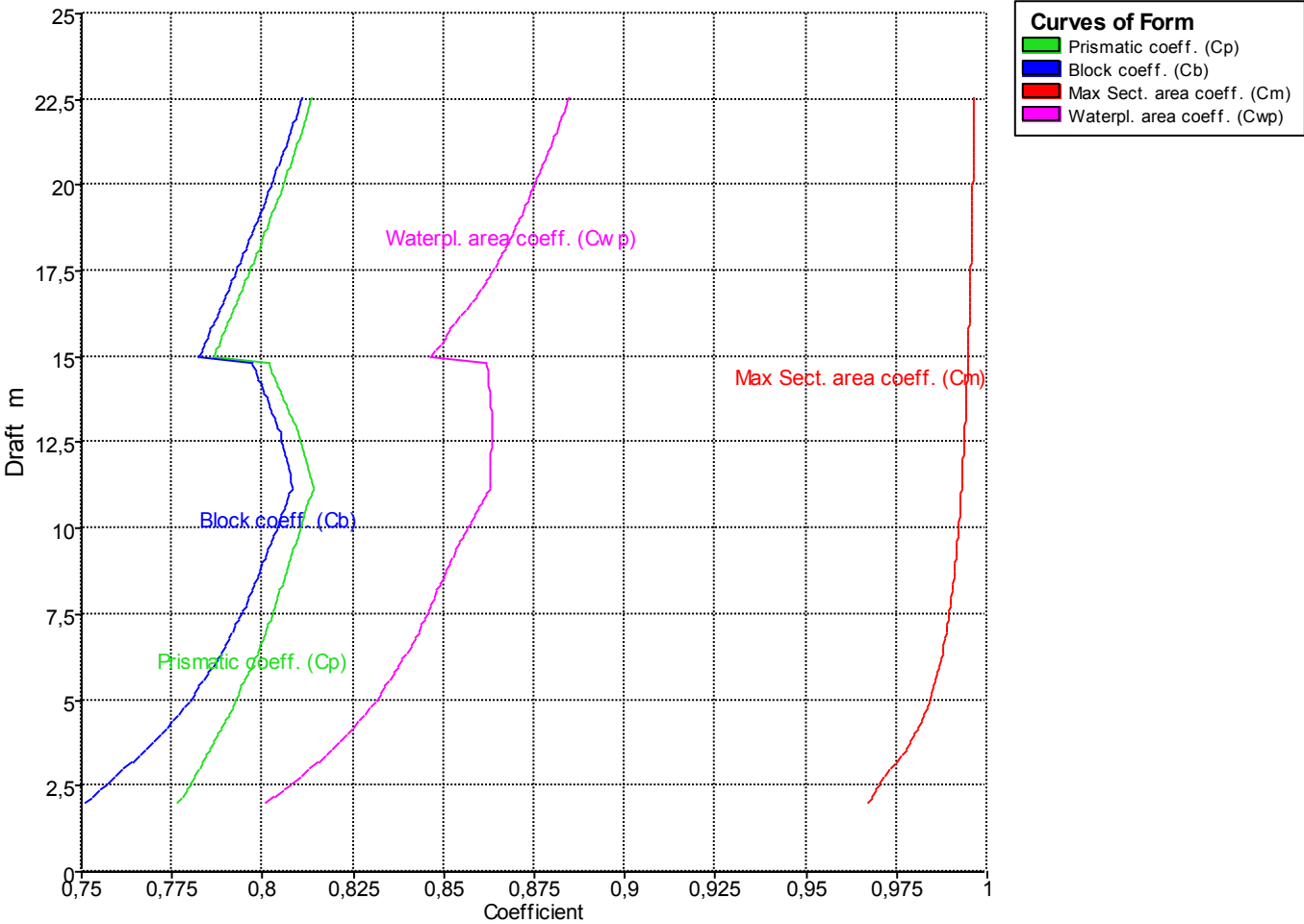

• **Para un trimado de 1,6 m:**

Draft Amidships m	Displacement t	Draft at LCF m	Trim (+ve by stern) m	WL Length m	Beam max extents on WL m	Wetted Area m ²	Waterpl. Area m ²	Block coeff. (Cb)	LCB from zero pt. (+ve fwd) m	LCF from zero pt. (+ve fwd) m	KB m	BMt m	BML m	KMt m	KML m	Immersion (TPc) tonne/cm	MTC tonne.m
2,000	27418	1,962	1,600	303,589	59,726	14958,239	14527,839	0,739	156,977	170,178	1,048	134,336	2959,716	135,383	2960,728	148,910	2479,216
2,200	30408	2,161	1,600	304,242	59,845	15129,779	14632,941	0,742	158,288	170,378	1,147	122,907	2707,906	124,053	2709,021	149,988	2514,046
2,400	33418	2,360	1,600	304,895	59,917	15294,006	14727,464	0,744	159,388	170,540	1,248	113,318	2496,093	114,565	2497,310	150,957	2545,259
2,600	36447	2,560	1,600	305,548	59,981	15453,458	14813,820	0,747	160,326	170,704	1,349	105,114	2316,605	106,461	2317,925	151,842	2574,801
2,800	39492	2,759	1,600	306,037	59,996	15608,801	14891,267	0,750	161,132	170,848	1,450	98,001	2161,888	99,449	2163,312	152,635	2602,028
3,000	42552	2,958	1,600	306,448	60,000	15762,633	14963,824	0,753	161,835	170,977	1,551	91,794	2028,061	93,344	2029,588	153,379	2628,577
3,200	45627	3,158	1,600	306,860	60,000	15914,702	15031,238	0,756	162,456	171,092	1,653	86,316	1910,912	87,967	1912,542	154,070	2654,188
3,400	48715	3,357	1,600	307,272	60,000	16064,859	15094,143	0,758	163,007	171,203	1,754	81,444	1807,390	83,198	1809,123	154,715	2678,817
3,600	51816	3,557	1,600	307,685	60,000	16211,791	15151,902	0,761	163,502	171,311	1,856	77,085	1714,674	78,941	1716,509	155,307	2701,668
3,800	54929	3,756	1,600	308,097	60,000	16357,820	15207,483	0,763	163,949	171,408	1,958	73,180	1631,739	75,138	1633,677	155,877	2723,961
4,000	58053	3,956	1,600	308,509	60,000	16502,694	15260,642	0,765	164,355	171,492	2,060	69,661	1556,938	71,720	1558,980	156,422	2745,456
4,200	61188	4,155	1,600	308,922	60,000	16646,584	15311,635	0,767	164,726	171,564	2,163	66,472	1489,130	68,633	1491,275	156,944	2766,249
4,400	64333	4,355	1,600	309,308	60,000	16789,394	15360,740	0,769	165,064	171,628	2,265	63,566	1427,447	65,830	1429,695	157,448	2786,542
4,600	67486	4,555	1,600	309,599	60,000	16930,996	15406,912	0,771	165,372	171,681	2,367	60,903	1370,797	63,270	1373,147	157,921	2805,725
4,800	70649	4,755	1,600	309,890	60,000	17071,767	15450,999	0,772	165,656	171,735	2,470	58,450	1318,780	60,919	1321,234	158,373	2824,376
5,000	73821	4,954	1,600	310,181	60,000	17211,316	15492,697	0,774	165,918	171,787	2,572	56,181	1270,718	58,753	1273,275	158,800	2842,245
5,200	77001	5,154	1,600	310,472	60,000	17349,766	15532,456	0,776	166,161	171,832	2,675	54,082	1226,164	56,756	1228,824	159,208	2859,372
5,400	80190	5,354	1,600	310,762	60,000	17487,853	15571,313	0,777	166,388	171,869	2,777	52,138	1184,913	54,915	1187,676	159,606	2876,240
5,600	83386	5,554	1,600	311,053	60,000	17625,303	15608,861	0,778	166,598	171,894	2,880	50,333	1146,477	53,212	1149,343	159,991	2892,530
5,800	86590	5,754	1,600	311,344	60,000	17762,698	15645,850	0,780	166,795	171,915	2,983	48,653	1110,729	51,635	1113,698	160,370	2908,704
6,000	89801	5,954	1,600	311,635	60,000	17899,461	15681,690	0,781	166,979	171,923	3,085	47,085	1077,249	50,170	1080,321	160,737	2924,361
6,200	93020	6,154	1,600	311,922	60,000	18036,037	15716,909	0,782	167,151	171,920	3,188	45,618	1045,941	48,805	1049,117	161,098	2939,874
6,400	96246	6,354	1,600	312,129	60,000	18172,045	15750,794	0,783	167,311	171,907	3,291	44,241	1016,441	47,531	1019,720	161,446	2954,779
6,600	99480	6,554	1,600	312,362	60,000	18308,058	15784,277	0,785	167,462	171,893	3,394	42,945	988,804	46,338	992,186	161,789	2969,763
6,800	102720	6,754	1,600	312,615	60,000	18443,597	15816,215	0,786	167,602	171,876	3,497	41,718	962,676	45,214	966,160	162,116	2984,236
7,000	105966	6,954	1,600	312,869	60,000	18578,936	15847,361	0,787	167,735	171,856	3,599	40,556	938,076	44,155	941,664	162,435	2998,692
7,200	109220	7,154	1,600	313,122	60,000	18713,669	15877,145	0,788	167,859	171,829	3,702	39,453	914,738	43,155	918,430	162,741	3012,671
7,400	112479	7,354	1,600	313,375	60,000	18848,438	15906,368	0,789	167,975	171,802	3,805	38,409	892,646	42,214	896,441	163,040	3026,478
7,600	115745	7,554	1,600	313,628	60,000	18982,934	15934,855	0,790	168,085	171,767	3,908	37,421	871,638	41,329	875,536	163,332	3039,894
7,800	119014	7,755	1,600	313,881	60,000	19117,699	15963,816	0,790	168,185	171,722	4,011	36,484	851,882	40,495	855,883	163,629	3053,807
8,000	122290	7,955	1,600	314,128	60,000	19252,180	15991,831	0,791	168,279	171,661	4,114	35,595	832,988	39,709	837,092	163,916	3067,148
8,200	125571	8,155	1,600	314,311	60,000	19386,614	16019,391	0,792	168,367	171,592	4,217	34,750	814,979	38,967	819,186	164,199	3080,264
8,400	128858	8,356	1,600	314,495	60,000	19521,231	16046,872	0,793	168,448	171,518	4,320	33,947	797,861	38,267	802,171	164,480	3093,430
8,600	132151	8,556	1,600	314,679	60,000	19656,283	16074,675	0,794	168,523	171,435	4,423	33,181	781,632	37,604	786,046	164,765	3106,903

PETROLERO VLCC DE 300.000 TPM

CUADERNO IV: COMPARTIMENTADO Y CÁLCULOS DE ARQUITECTURA NAVAL

PEDRO LEMOS GONZÁLEZ

Draft Amidships m	Displacement t	Draft at LCF m	Trim (+ve by stern) m	WL Length m	Beam max extents on WL m	Wetted Area m ²	Waterpl. Area m ²	Block coeff. (Cb)	LCB from zero pt. (+ve fwd) m	LCF from zero pt. (+ve fwd) m	KB m	BMt m	BML m	KMt m	KML m	Immersion (TPc) tonne/cm	MTc tonne.m
8,800	135449	8,756	1,600	314,863	60,000	19791,767	16102,961	0,795	168,593	171,342	4,527	32,451	766,265	36,977	770,783	165,055	3120,838
9,000	138753	8,957	1,600	315,046	60,000	19927,257	16131,279	0,796	168,657	171,239	4,630	31,754	751,627	36,384	756,248	165,346	3134,915
9,200	142063	9,158	1,600	315,230	60,000	20063,062	16159,687	0,797	168,716	171,132	4,733	31,088	737,670	35,821	742,394	165,637	3149,143
9,400	145379	9,358	1,600	315,414	60,000	20199,479	16188,373	0,797	168,769	171,011	4,836	30,451	724,378	35,287	729,205	165,931	3163,653
9,600	148701	9,559	1,600	315,598	60,000	20335,828	16216,583	0,798	168,818	170,886	4,939	29,841	711,588	34,781	716,519	166,220	3177,895
9,800	152028	9,759	1,600	315,740	60,000	20471,736	16244,437	0,799	168,862	170,758	5,043	29,254	699,178	34,296	704,213	166,495	3191,440
10,000	155361	9,960	1,600	315,868	60,000	20608,022	16270,167	0,800	168,901	170,625	5,146	28,687	687,331	33,833	692,469	166,769	3205,268
10,200	158700	10,161	1,600	315,997	60,000	20745,116	16298,149	0,801	168,935	170,477	5,250	28,142	676,172	33,392	681,413	167,056	3220,164
10,400	162045	10,361	1,600	316,125	60,000	20881,238	16326,231	0,801	168,966	170,327	5,353	27,619	665,475	32,972	670,820	167,344	3235,205
10,600	165395	10,562	1,600	316,537	60,000	21018,822	16354,494	0,802	168,991	170,172	5,457	27,117	655,209	32,573	660,658	167,634	3250,374
10,800	168750	10,763	1,600	317,112	60,000	21129,490	16382,522	0,801	169,013	170,014	5,560	26,634	645,303	32,194	650,856	167,921	3265,421
11,000	172112	10,964	1,600	317,687	60,000	21268,206	16412,922	0,801	169,031	169,831	5,664	26,170	636,122	31,833	641,778	168,232	3282,393
11,200	175479	11,165	1,600	318,262	60,000	21408,113	16444,331	0,800	169,044	169,634	5,768	25,723	627,426	31,490	633,186	168,554	3300,230
11,400	178854	11,366	1,600	318,837	60,000	21548,515	16475,986	0,800	169,054	169,428	5,871	25,292	619,075	31,163	624,939	168,879	3318,309
11,600	182235	11,567	1,600	319,387	60,000	21689,343	16508,048	0,800	169,058	169,210	5,975	24,876	611,080	30,851	617,047	169,207	3336,788
11,800	185623	11,768	1,600	319,935	60,000	21830,467	16540,319	0,799	169,059	168,989	6,079	24,476	603,382	30,555	609,454	169,538	3355,449
12,000	189016	11,969	1,600	320,484	60,000	21972,543	16571,518	0,799	169,056	168,778	6,183	24,090	595,787	30,272	601,963	169,858	3373,232
12,200	192417	12,170	1,600	321,147	60,000	22116,043	16605,243	0,799	169,049	168,540	6,287	23,715	588,821	30,002	595,101	170,204	3393,291
12,400	195825	12,371	1,600	321,832	60,000	22259,336	16638,316	0,798	169,038	168,306	6,391	23,352	582,030	29,743	588,414	170,543	3413,094
12,600	199239	12,573	1,600	322,517	60,000	22402,878	16671,255	0,797	169,023	168,072	6,496	22,999	575,464	29,494	581,953	170,880	3432,990
12,800	202660	12,774	1,600	323,203	60,000	22546,360	16703,761	0,797	169,005	167,839	6,600	22,656	569,067	29,256	575,660	171,214	3452,693
13,000	206087	12,975	1,600	323,888	60,000	22687,699	16733,121	0,796	168,984	167,636	6,704	22,324	562,455	29,028	569,153	171,514	3469,823
13,200	209521	13,176	1,600	324,573	60,000	22833,408	16767,184	0,795	168,960	167,384	6,809	22,002	556,686	28,811	563,488	171,864	3491,112
13,400	212962	13,377	1,600	325,258	60,000	22977,609	16799,307	0,794	168,932	167,150	6,913	21,691	550,835	28,604	557,741	172,193	3510,784
13,600	216409	13,578	1,600	325,940	60,000	23122,695	16831,926	0,794	168,902	166,905	7,018	21,388	545,230	28,406	552,241	172,527	3530,986
13,800	219863	13,780	1,600	326,616	60,000	23268,708	16865,318	0,793	168,869	166,651	7,123	21,095	539,892	28,218	547,008	172,870	3551,941
14,000	223323	13,981	1,600	327,292	60,000	23412,736	16896,371	0,792	168,832	166,420	7,227	20,811	534,401	28,038	541,621	173,188	3570,830
14,200	226790	14,182	1,600	333,942	60,000	23559,258	16929,747	0,778	168,793	166,166	7,332	20,535	529,375	27,867	536,701	173,530	3591,930
14,400	230264	14,383	1,600	333,943	60,000	23705,704	16962,136	0,779	168,752	165,917	7,437	20,263	524,458	27,700	531,888	173,862	3612,852
14,600	233745	14,584	1,600	333,944	60,000	23851,762	16993,446	0,780	168,708	165,676	7,542	19,996	519,602	27,538	527,138	174,183	3633,292
14,800	237231	14,786	1,600	333,945	60,000	23997,446	17023,883	0,780	168,662	165,442	7,647	19,735	514,805	27,382	522,446	174,495	3653,236
15,000	240724	14,986	1,600	333,947	60,000	24137,311	17047,608	0,781	168,614	165,273	7,752	19,480	509,343	27,232	517,089	174,738	3667,344
15,200	244222	15,188	1,600	333,948	60,000	24285,797	17080,120	0,782	168,564	165,016	7,857	19,232	505,110	27,089	512,961	175,071	3689,610
15,400	247727	15,389	1,600	333,949	60,000	24433,674	17111,799	0,783	168,512	164,766	7,962	18,990	500,903	26,952	508,859	175,396	3711,290
15,600	251238	15,590	1,600	333,950	60,000	24580,631	17142,253	0,784	168,458	164,527	8,068	18,754	496,672	26,821	504,734	175,708	3731,993
15,800	254755	15,791	1,600	333,951	60,000	24726,558	17171,206	0,785	168,402	164,302	8,173	18,525	492,382	26,697	500,549	176,005	3751,433
16,000	258277	15,992	1,600	333,953	60,000	24867,576	17194,519	0,786	168,345	164,131	8,278	18,301	487,546	26,579	495,818	176,244	3765,695
16,200	261805	16,193	1,600	333,954	60,000	25014,608	17223,579	0,787	168,287	163,902	8,383	18,083	483,498	26,466	491,876	176,542	3785,375

PETROLERO VLCC DE 300.000 TPM

CUADERNO IV: COMPARTIMENTADO Y CÁLCULOS DE ARQUITECTURA NAVAL

PEDRO LEMOS GONZÁLEZ

Draft Amidships m	Displacement t	Draft at LCF m	Trim (+ve by stern) m	WL Length m	Beam max extents on WL m	Wetted Area m ²	Waterpl. Area m ²	Block coeff. (Cb)	LCB from zero pt. (+ve fwd) m	LCF from zero pt. (+ve fwd) m	KB m	BMt m	BML m	KMt m	KML m	Immersion (TPc) tonne/cm	MTc tonne.m
16,400	265338	16,394	1,600	333,954	60,000	25159,273	17249,598	0,788	168,227	163,704	8,489	17,871	479,202	26,360	487,685	176,808	3802,245
16,600	268877	16,595	1,600	333,954	60,000	25303,100	17274,118	0,789	168,167	163,519	8,594	17,664	474,863	26,258	483,451	177,060	3817,928
16,800	272420	16,796	1,600	333,954	60,000	25446,176	17296,928	0,790	168,105	163,348	8,700	17,459	470,494	26,158	479,188	177,294	3832,503
17,000	275968	16,997	1,600	333,954	60,000	25588,759	17318,640	0,790	168,043	163,187	8,805	17,258	466,147	26,063	474,947	177,516	3846,403
17,200	279521	17,197	1,600	333,954	60,000	25731,039	17339,587	0,791	167,980	163,031	8,910	17,061	461,852	25,971	470,757	177,731	3859,876
17,400	283077	17,398	1,600	333,954	60,000	25872,983	17359,787	0,792	167,917	162,882	9,016	16,867	457,605	25,883	466,615	177,938	3872,916
17,600	286638	17,599	1,600	333,954	60,000	26014,587	17379,273	0,793	167,853	162,738	9,121	16,677	453,406	25,798	462,521	178,138	3885,521
17,800	290203	17,800	1,600	333,954	60,000	26155,881	17398,124	0,794	167,790	162,600	9,227	16,492	449,254	25,718	458,475	178,331	3897,704
18,000	293771	18,000	1,600	333,954	60,000	26296,870	17416,364	0,795	167,726	162,466	9,332	16,310	445,151	25,642	454,478	178,518	3909,502
18,200	297343	18,201	1,600	333,954	60,000	26437,591	17434,071	0,795	167,662	162,338	9,437	16,132	441,101	25,569	450,533	178,699	3920,948
18,400	300919	18,401	1,600	333,954	60,000	26578,062	17451,265	0,796	167,598	162,213	9,543	15,958	437,102	25,500	446,640	178,875	3932,043
18,600	304498	18,602	1,600	333,954	60,000	26718,292	17467,962	0,797	167,534	162,092	9,648	15,787	433,152	25,435	442,795	179,047	3942,788
18,800	308081	18,803	1,600	333,954	60,000	26858,361	17484,297	0,798	167,470	161,974	9,753	15,621	429,261	25,374	439,009	179,214	3953,282
19,000	311667	19,003	1,600	333,954	60,000	26998,189	17500,196	0,799	167,406	161,861	9,859	15,458	425,420	25,316	435,273	179,377	3963,466
19,200	315256	19,204	1,600	333,954	60,000	27137,891	17515,833	0,799	167,342	161,750	9,964	15,298	421,637	25,262	431,596	179,537	3973,439
19,400	318848	19,404	1,600	333,954	60,000	27277,442	17531,174	0,800	167,279	161,642	10,069	15,143	417,911	25,211	427,975	179,695	3983,190
19,600	322444	19,605	1,600	333,954	60,000	27416,936	17546,364	0,801	167,215	161,536	10,174	14,990	414,250	25,164	424,420	179,850	3992,823
19,800	326042	19,805	1,600	333,954	60,000	27556,300	17561,281	0,802	167,152	161,433	10,280	14,841	410,642	25,121	420,917	180,003	4002,242
20,000	329644	20,006	1,600	333,954	60,000	27695,769	17576,201	0,803	167,089	161,330	10,385	14,696	407,108	25,080	417,488	180,156	4011,665
20,200	333248	20,206	1,600	333,954	60,000	27835,170	17590,869	0,803	167,026	161,231	10,490	14,553	403,625	25,043	414,110	180,306	4020,892
20,400	336856	20,407	1,600	333,954	60,000	27974,516	17605,365	0,804	166,964	161,133	10,595	14,413	400,198	25,008	410,788	180,455	4029,988
20,600	340466	20,607	1,600	333,954	60,000	28113,796	17619,671	0,805	166,901	161,038	10,700	14,277	396,823	24,977	407,519	180,602	4038,928
20,800	344080	20,808	1,600	333,954	60,000	28253,100	17634,001	0,805	166,839	160,945	10,805	14,143	393,517	24,948	404,318	180,749	4047,906
21,000	347696	21,008	1,600	333,954	60,000	28392,342	17647,909	0,806	166,777	160,858	10,910	14,011	390,263	24,921	401,168	180,891	4056,753
21,200	351315	21,208	1,600	333,954	60,000	28531,461	17661,258	0,807	166,716	160,778	11,015	13,881	387,047	24,896	398,058	181,028	4065,354
21,400	354937	21,409	1,600	333,954	60,000	28670,484	17674,114	0,808	166,655	160,703	11,121	13,752	383,871	24,872	394,987	181,160	4073,722
21,600	358562	21,609	1,600	333,954	60,000	28809,372	17686,584	0,808	166,595	160,634	11,226	13,625	380,738	24,851	391,959	181,287	4081,907
21,800	362189	21,809	1,600	333,958	60,000	28948,185	17698,949	0,809	166,535	160,571	11,331	13,501	377,664	24,831	388,990	181,414	4090,103
22,000	365818	22,010	1,600	333,971	60,000	29084,337	17711,662	0,810	166,475	160,519	11,436	13,378	374,676	24,814	386,107	181,545	4098,644
22,200	369450	22,210	1,600	333,985	60,000	29223,173	17724,619	0,810	166,416	160,476	11,541	13,258	371,768	24,799	383,304	181,677	4107,465
22,400	373085	22,410	1,600	333,998	60,000	29361,908	17737,312	0,811	166,358	160,439	11,645	13,140	368,900	24,785	380,541	181,807	4116,160
22,600	376723	22,610	1,600	334,012	60,000	29500,446	17749,509	0,811	166,301	160,407	11,750	13,024	366,056	24,774	377,802	181,932	4124,534

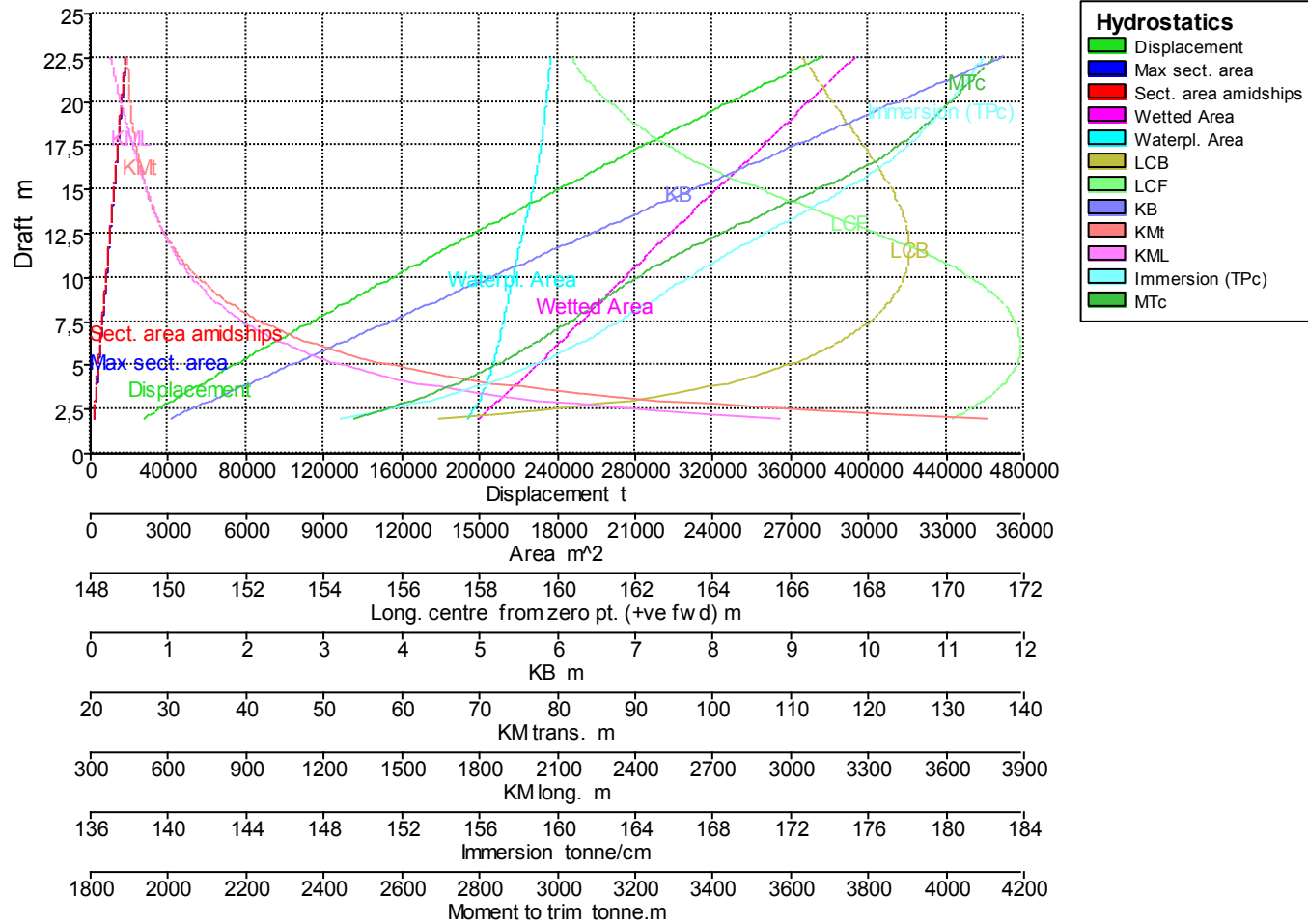

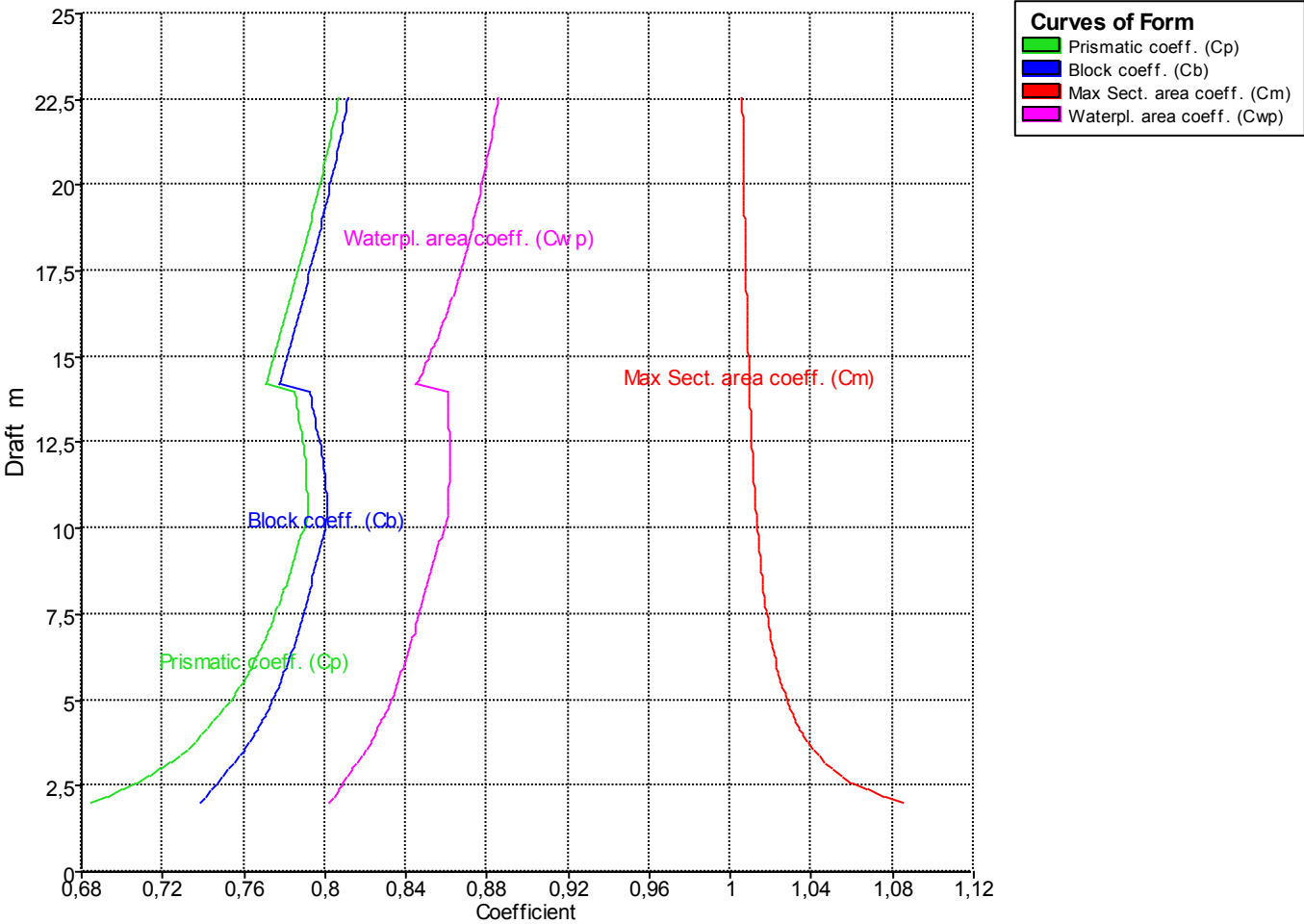

• **Para un trimado de 3,2 m:**

Draft Amidships m	Displacement t	Draft at LCF m	Trim (+ve by stern) m	WL Length m	Beam max extents on WL m	Wetted Area m ²	Waterpl. Area m ²	Block coeff. (Cb)	LCB from zero pt. (+ve fwd) m	LCF from zero pt. (+ve fwd) m	KB m	BMt m	BML m	KMt m	KML m	Immersion (TPc) tonne/cm	MTC tonne.m
2,000	26935	1,946	3,200	300,810	59,824	14859,131	14402,574	0,733	142,088	167,951	1,140	135,298	2939,430	136,431	2940,428	147,626	2418,614
2,200	29900	2,142	3,200	302,157	59,900	15042,915	14521,793	0,734	144,678	168,348	1,229	123,806	2694,942	125,029	2696,041	148,848	2460,113
2,400	32888	2,339	3,200	302,801	59,972	15216,383	14626,200	0,738	146,843	168,667	1,321	114,125	2487,692	115,441	2488,892	149,919	2496,323
2,600	35897	2,536	3,200	303,446	59,992	15385,587	14722,869	0,741	148,685	168,952	1,415	105,872	2312,027	107,282	2313,330	150,909	2530,768
2,800	38924	2,734	3,200	304,091	60,000	15550,318	14811,514	0,744	150,272	169,198	1,510	98,737	2160,658	100,242	2162,063	151,818	2563,064
3,000	41969	2,932	3,200	304,736	60,000	15710,200	14890,791	0,746	151,656	169,432	1,606	92,456	2028,498	94,057	2030,005	152,631	2593,062
3,200	45030	3,130	3,200	305,381	60,000	15864,677	14961,610	0,749	152,875	169,631	1,703	86,912	1911,384	88,610	1912,995	153,357	2620,063
3,400	48105	3,328	3,200	306,026	60,000	16017,921	15030,158	0,752	153,955	169,824	1,800	82,010	1808,634	83,806	1810,347	154,059	2647,049
3,600	51193	3,526	3,200	306,663	60,000	16168,376	15093,580	0,754	154,916	169,978	1,898	77,645	1716,422	79,540	1718,237	154,709	2671,870
3,800	54293	3,725	3,200	306,873	60,000	16317,868	15154,649	0,757	155,781	170,120	1,997	73,732	1634,028	75,726	1635,946	155,335	2696,223
4,000	57406	3,924	3,200	307,282	60,000	16465,950	15212,739	0,759	156,562	170,247	2,096	70,198	1559,710	72,291	1561,730	155,931	2719,720
4,200	60531	4,123	3,200	307,691	60,000	16612,775	15267,866	0,762	157,272	170,367	2,196	66,982	1492,349	69,174	1494,472	156,496	2742,490
4,400	63666	4,321	3,200	308,100	60,000	16757,384	15318,982	0,764	157,921	170,476	2,295	64,036	1430,634	66,329	1432,860	157,020	2763,868
4,600	66812	4,520	3,200	308,509	60,000	16900,686	15367,613	0,766	158,516	170,585	2,396	61,333	1374,178	63,726	1376,507	157,518	2784,603
4,800	69968	4,719	3,200	308,918	60,000	17042,785	15414,233	0,767	159,065	170,681	2,496	58,854	1322,228	61,347	1324,660	157,996	2804,530
5,000	73134	4,919	3,200	309,327	60,000	17184,188	15459,368	0,769	159,572	170,765	2,596	56,572	1274,355	59,166	1276,890	158,459	2823,936
5,200	76309	5,118	3,200	309,696	60,000	17324,731	15503,835	0,770	160,041	170,841	2,697	54,467	1230,288	57,161	1232,926	158,914	2843,297
5,400	79491	5,317	3,200	309,986	60,000	17464,571	15546,213	0,772	160,475	170,898	2,798	52,516	1189,216	55,312	1191,956	159,349	2861,679
5,600	82683	5,517	3,200	310,275	60,000	17604,523	15588,357	0,774	160,878	170,948	2,899	50,707	1151,233	53,604	1154,077	159,781	2880,200
5,800	85882	5,716	3,200	310,580	60,000	17743,732	15629,004	0,775	161,254	170,986	3,001	49,021	1115,716	52,019	1118,663	160,197	2898,085
6,000	89090	5,916	3,200	310,916	60,000	17882,701	15668,769	0,777	161,605	171,014	3,102	47,445	1082,567	50,545	1085,616	160,605	2915,756
6,200	92307	6,116	3,200	311,252	60,000	18021,238	15707,230	0,778	161,933	171,035	3,204	45,967	1051,477	49,169	1054,630	160,999	2933,010
6,400	95531	6,316	3,200	311,588	60,000	18159,431	15744,605	0,779	162,240	171,045	3,305	44,573	1022,383	47,876	1025,639	161,382	2950,240
6,600	98762	6,516	3,200	311,924	60,000	18296,801	15779,904	0,780	162,529	171,057	3,407	43,253	994,874	46,658	998,233	161,744	2966,760
6,800	102001	6,716	3,200	312,260	60,000	18433,372	15813,703	0,781	162,800	171,065	3,509	42,009	968,812	45,516	972,274	162,090	2982,582
7,000	105246	6,916	3,200	312,587	60,000	18569,469	15846,388	0,782	163,056	171,060	3,611	40,835	944,137	44,444	947,702	162,425	2997,919
7,200	108499	7,116	3,200	312,839	60,000	18705,827	15879,386	0,783	163,296	171,041	3,713	39,728	920,973	43,439	924,641	162,764	3013,585
7,400	111758	7,316	3,200	313,092	60,000	18842,078	15911,855	0,784	163,523	171,015	3,815	38,680	899,055	42,494	902,826	163,097	3029,104
7,600	115025	7,516	3,200	313,345	60,000	18978,215	15943,977	0,785	163,736	170,984	3,918	37,688	878,298	41,604	882,173	163,426	3044,540
7,800	118298	7,717	3,200	313,597	60,000	19114,632	15976,177	0,786	163,938	170,942	4,020	36,748	858,690	40,766	862,669	163,756	3060,182
8,000	121578	7,917	3,200	313,850	60,000	19251,325	16008,194	0,787	164,128	170,890	4,122	35,855	840,101	39,976	844,183	164,084	3075,877
8,200	124864	8,118	3,200	314,103	60,000	19388,478	16040,943	0,788	164,306	170,824	4,225	35,006	822,615	39,230	826,800	164,420	3092,247
8,400	128158	8,319	3,200	314,355	60,000	19525,270	16072,834	0,789	164,475	170,751	4,328	34,198	805,866	38,524	810,154	164,747	3108,173
8,600	131456	8,520	3,200	314,608	60,000	19662,637	16105,767	0,790	164,631	170,670	4,430	33,428	790,139	37,857	794,531	165,084	3124,981
8,800	134761	8,721	3,200	314,852	60,000	19799,852	16137,417	0,791	164,778	170,573	4,533	32,694	774,944	37,226	779,439	165,409	3140,971

PETROLERO VLCC DE 300.000 TPM

CUADERNO IV: COMPARTIMENTADO Y CÁLCULOS DE ARQUITECTURA NAVAL

PEDRO LEMOS GONZÁLEZ

Draft Amidships m	Displacement t	Draft at LCF m	Trim (+ve by stern) m	WL Length m	Beam max extents on WL m	Wetted Area m ²	Waterpl. Area m ²	Block coeff. (Cb)	LCB from zero pt. (+ve fwd) m	LCF from zero pt. (+ve fwd) m	KB m	BMt m	BML m	KMt m	KML m	Immersion (TPc) tonne/cm	MTc tonne.m
9,000	138073	8,922	3,200	315,036	60,000	19936,818	16168,311	0,792	164,916	170,469	4,636	31,993	760,336	36,627	764,935	165,725	3156,536
9,200	141390	9,123	3,200	315,220	60,000	20073,935	16199,044	0,793	165,044	170,363	4,739	31,322	746,384	36,059	751,086	166,040	3172,139
9,400	144714	9,324	3,200	315,403	60,000	20211,710	16230,445	0,794	165,165	170,240	4,842	30,676	733,243	35,517	738,049	166,362	3188,667
9,600	148045	9,525	3,200	315,587	60,000	20349,526	16261,500	0,795	165,277	170,115	4,945	30,056	720,658	35,000	725,568	166,680	3205,202
9,800	151382	9,726	3,200	315,964	60,000	20487,720	16292,372	0,795	165,382	169,983	5,048	29,461	708,599	34,508	713,613	166,997	3221,764
10,000	154725	9,928	3,200	316,602	60,000	20599,090	16322,791	0,795	165,480	169,850	5,152	28,890	696,970	34,040	702,088	167,309	3238,045
10,200	158074	10,129	3,200	317,239	60,000	20737,861	16354,867	0,794	165,571	169,693	5,255	28,342	686,097	33,596	691,319	167,637	3255,763
10,400	161430	10,331	3,200	317,876	60,000	20878,023	16388,093	0,794	165,655	169,513	5,359	27,816	675,849	33,173	681,175	167,978	3274,502
10,600	164793	10,533	3,200	318,472	60,000	21018,665	16421,340	0,794	165,732	169,322	5,462	27,311	666,007	32,771	671,437	168,319	3293,342
10,800	168163	10,735	3,200	319,054	60,000	21159,781	16455,256	0,794	165,802	169,121	5,566	26,824	656,646	32,389	662,180	168,666	3312,798
11,000	171541	10,937	3,200	319,636	60,000	21301,284	16489,451	0,793	165,865	168,915	5,670	26,357	647,677	32,025	653,316	169,017	3332,539
11,200	174924	11,139	3,200	320,218	60,000	21442,341	16522,444	0,793	165,923	168,721	5,774	25,906	638,844	31,679	644,587	169,355	3351,296
11,400	178315	11,341	3,200	320,904	60,000	21586,209	16558,125	0,793	165,974	168,495	5,878	25,472	630,745	31,349	636,592	169,721	3372,390
11,600	181713	11,543	3,200	321,627	60,000	21730,228	16593,772	0,792	166,019	168,267	5,982	25,054	622,936	31,034	628,887	170,086	3393,575
11,800	185118	11,745	3,200	322,350	60,000	21874,226	16628,747	0,791	166,058	168,039	6,086	24,647	615,347	30,732	621,403	170,445	3414,539
12,000	188531	11,948	3,200	323,074	60,000	22018,123	16663,148	0,791	166,092	167,813	6,190	24,254	607,957	30,443	614,118	170,797	3435,220
12,200	191950	12,150	3,200	323,797	60,000	22159,617	16693,718	0,790	166,120	167,616	6,295	23,872	600,294	30,166	606,559	171,111	3452,878
12,400	195375	12,352	3,200	324,495	60,000	22305,541	16728,862	0,790	166,144	167,367	6,399	23,503	593,560	29,901	599,930	171,471	3474,651
12,600	198808	12,554	3,200	325,192	60,000	22450,040	16762,054	0,789	166,163	167,134	6,504	23,146	586,776	29,648	593,252	171,811	3494,841
12,800	202248	12,757	3,200	325,888	60,000	22595,261	16795,728	0,788	166,178	166,896	6,608	22,800	580,288	29,407	586,868	172,156	3515,582
13,000	205694	12,959	3,200	326,585	60,000	22741,527	16830,373	0,788	166,188	166,647	6,713	22,465	574,144	29,177	580,829	172,511	3537,267
13,200	209147	13,161	3,200	327,281	60,000	22885,821	16862,547	0,787	166,194	166,423	6,818	22,140	567,845	28,957	574,635	172,841	3556,793
13,400	212608	13,364	3,200	333,901	60,000	23032,662	16897,160	0,773	166,195	166,172	6,923	21,826	562,078	28,748	568,973	173,196	3578,598
13,600	216075	13,566	3,200	333,912	60,000	23179,975	16932,136	0,774	166,193	165,917	7,028	21,522	556,529	28,549	563,530	173,554	3600,770
13,800	219549	13,769	3,200	333,922	60,000	23326,683	16965,552	0,775	166,187	165,672	7,133	21,223	551,028	28,355	558,134	173,897	3622,209
14,000	223030	13,971	3,200	333,933	60,000	23472,825	16997,551	0,776	166,177	165,436	7,238	20,929	545,574	28,167	552,785	174,225	3642,935
14,200	226517	14,173	3,200	333,943	60,000	23613,540	17022,826	0,777	166,164	165,262	7,343	20,643	539,450	27,985	546,768	174,484	3657,947
14,400	230010	14,375	3,200	333,950	60,000	23762,330	17056,165	0,778	166,148	165,003	7,449	20,363	534,577	27,811	542,000	174,826	3680,606
14,600	233510	14,578	3,200	333,952	60,000	23910,301	17088,322	0,779	166,129	164,752	7,554	20,091	529,712	27,644	537,240	175,155	3702,407
14,800	237016	14,780	3,200	333,953	60,000	24057,462	17119,337	0,780	166,107	164,512	7,659	19,826	524,854	27,485	532,487	175,473	3723,332
15,000	240528	14,982	3,200	333,954	60,000	24203,676	17148,919	0,781	166,082	164,286	7,765	19,568	519,964	27,332	527,704	175,776	3743,098
15,200	244045	15,184	3,200	333,955	60,000	24345,312	17173,030	0,782	166,056	164,114	7,870	19,317	514,536	27,187	522,382	176,024	3757,865
15,400	247569	15,386	3,200	333,957	60,000	24491,954	17201,960	0,783	166,026	163,894	7,976	19,074	509,843	27,049	517,794	176,320	3777,171
15,600	251098	15,588	3,200	333,958	60,000	24636,506	17228,165	0,784	165,995	163,700	8,082	18,836	504,946	26,917	513,003	176,589	3793,988
15,800	254632	15,790	3,200	333,959	60,000	24780,268	17253,120	0,785	165,962	163,519	8,187	18,605	500,032	26,792	508,195	176,844	3809,713
16,000	258171	15,992	3,200	333,960	60,000	24923,660	17277,393	0,786	165,927	163,344	8,293	18,380	495,166	26,672	503,435	177,093	3824,849
16,200	261715	16,193	3,200	333,961	60,000	25066,533	17300,211	0,787	165,891	163,180	8,398	18,159	490,319	26,556	498,694	177,327	3839,170
16,400	265264	16,395	3,200	333,962	60,000	25209,128	17322,084	0,788	165,854	163,021	8,504	17,941	485,534	26,444	494,014	177,551	3853,031

PETROLERO VLCC DE 300.000 TPM

CUADERNO IV: COMPARTIMENTADO Y CÁLCULOS DE ARQUITECTURA NAVAL

PEDRO LEMOS GONZÁLEZ

Draft Amidships m	Displacement t	Draft at LCF m	Trim (+ve by stern) m	WL Length m	Beam max extents on WL m	Wetted Area m ²	Waterpl. Area m ²	Block coeff. (Cb)	LCB from zero pt. (+ve fwd) m	LCF from zero pt. (+ve fwd) m	KB m	BMt m	BML m	KMt m	KML m	Immersion (TPc) tonne/cm	MTC tonne.m
16,600	268817	16,596	3,200	333,964	60,000	25351,358	17343,012	0,788	165,815	162,870	8,610	17,727	480,803	26,336	489,389	177,766	3866,378
16,800	272374	16,798	3,200	333,965	60,000	25493,207	17363,035	0,789	165,776	162,724	8,715	17,517	476,120	26,232	484,812	177,971	3879,176
17,000	275935	16,999	3,200	333,966	60,000	25634,686	17382,255	0,790	165,736	162,584	8,821	17,312	471,489	26,132	480,287	178,168	3891,472
17,200	279500	17,201	3,200	333,966	60,000	25775,885	17400,882	0,791	165,695	162,448	8,927	17,111	466,925	26,037	475,829	178,359	3903,404
17,400	283069	17,402	3,200	333,966	60,000	25916,795	17418,931	0,792	165,653	162,318	9,032	16,914	462,425	25,946	471,435	178,544	3914,966
17,600	286642	17,603	3,200	333,966	60,000	26057,426	17436,421	0,793	165,610	162,192	9,138	16,722	457,986	25,859	467,102	178,723	3926,155
17,800	290218	17,804	3,200	333,966	60,000	26197,785	17453,392	0,794	165,568	162,071	9,243	16,534	453,609	25,777	462,830	178,897	3936,986
18,000	293797	18,005	3,200	333,966	60,000	26337,894	17469,881	0,795	165,524	161,954	9,349	16,351	449,294	25,699	458,621	179,066	3947,490
18,200	297380	18,206	3,200	333,966	60,000	26477,843	17486,043	0,796	165,481	161,840	9,454	16,172	445,051	25,625	454,484	179,232	3957,770
18,400	300966	18,408	3,200	333,966	60,000	26617,624	17501,845	0,796	165,437	161,730	9,560	15,996	440,873	25,556	450,412	179,394	3967,779
18,600	304555	18,609	3,200	333,966	60,000	26757,207	17517,256	0,797	165,392	161,622	9,665	15,825	436,757	25,490	446,401	179,552	3977,506
18,800	308148	18,810	3,200	333,966	60,000	26896,757	17532,516	0,798	165,348	161,516	9,771	15,658	432,718	25,428	442,468	179,708	3987,126
19,000	311743	19,011	3,200	333,966	60,000	27036,148	17547,424	0,799	165,303	161,413	9,876	15,494	428,738	25,370	438,594	179,861	3996,481
19,200	315342	19,212	3,200	333,966	60,000	27175,572	17562,295	0,800	165,258	161,311	9,982	15,334	424,841	25,315	434,802	180,014	4005,818
19,400	318944	19,413	3,200	333,966	60,000	27314,876	17576,854	0,800	165,213	161,210	10,087	15,178	421,001	25,264	431,068	180,163	4014,915
19,600	322548	19,614	3,200	333,966	60,000	27454,116	17591,215	0,801	165,168	161,112	10,193	15,025	417,225	25,216	427,397	180,310	4023,855
19,800	326156	19,815	3,200	333,966	60,000	27593,275	17605,357	0,802	165,122	161,015	10,298	14,875	413,508	25,172	423,786	180,455	4032,614
20,000	329766	20,016	3,200	333,966	60,000	27732,454	17619,477	0,803	165,077	160,920	10,403	14,729	409,866	25,131	420,249	180,600	4041,357
20,200	333379	20,216	3,200	333,966	60,000	27871,585	17633,427	0,804	165,031	160,826	10,508	14,586	406,282	25,093	416,771	180,743	4049,954
20,400	336995	20,417	3,200	333,966	60,000	28010,668	17646,911	0,804	164,985	160,737	10,614	14,445	402,750	25,058	413,344	180,881	4058,342
20,600	340614	20,618	3,200	333,966	60,000	28149,632	17659,598	0,805	164,940	160,653	10,719	14,305	399,254	25,023	409,953	181,011	4066,377
20,800	344235	20,819	3,200	333,966	60,000	28288,532	17671,665	0,806	164,894	160,573	10,824	14,167	395,797	24,991	406,602	181,135	4074,114
21,000	347859	21,020	3,200	333,966	60,000	28427,316	17683,144	0,807	164,849	160,499	10,929	14,031	392,382	24,960	403,292	181,252	4081,561
21,200	351485	21,220	3,200	333,966	60,000	28565,987	17694,219	0,807	164,804	160,427	11,034	13,898	389,012	24,931	400,028	181,366	4088,798
21,400	355113	21,421	3,200	333,966	60,000	28704,517	17704,888	0,808	164,759	160,361	11,140	13,766	385,687	24,905	396,807	181,475	4095,811
21,600	358744	21,622	3,200	333,966	60,000	28842,857	17715,153	0,809	164,714	160,300	11,245	13,637	382,403	24,881	393,629	181,580	4102,595
21,800	362376	21,822	3,200	333,966	60,000	28980,995	17725,045	0,809	164,669	160,245	11,350	13,510	379,162	24,859	390,493	181,682	4109,159
22,000	366011	22,023	3,200	333,966	60,000	29118,939	17734,551	0,810	164,625	160,197	11,455	13,385	375,958	24,839	387,394	181,779	4115,469
22,200	369647	22,223	3,200	333,966	60,000	29256,753	17743,758	0,811	164,581	160,153	11,560	13,263	372,794	24,822	384,336	181,874	4121,564
22,400	373285	22,423	3,200	333,966	60,000	29394,461	17752,787	0,811	164,538	160,114	11,665	13,143	369,678	24,807	381,324	181,966	4127,534
22,600	376925	22,624	3,200	333,970	60,000	29532,146	17761,946	0,812	164,495	160,081	11,770	13,025	366,625	24,794	378,377	182,060	4133,594

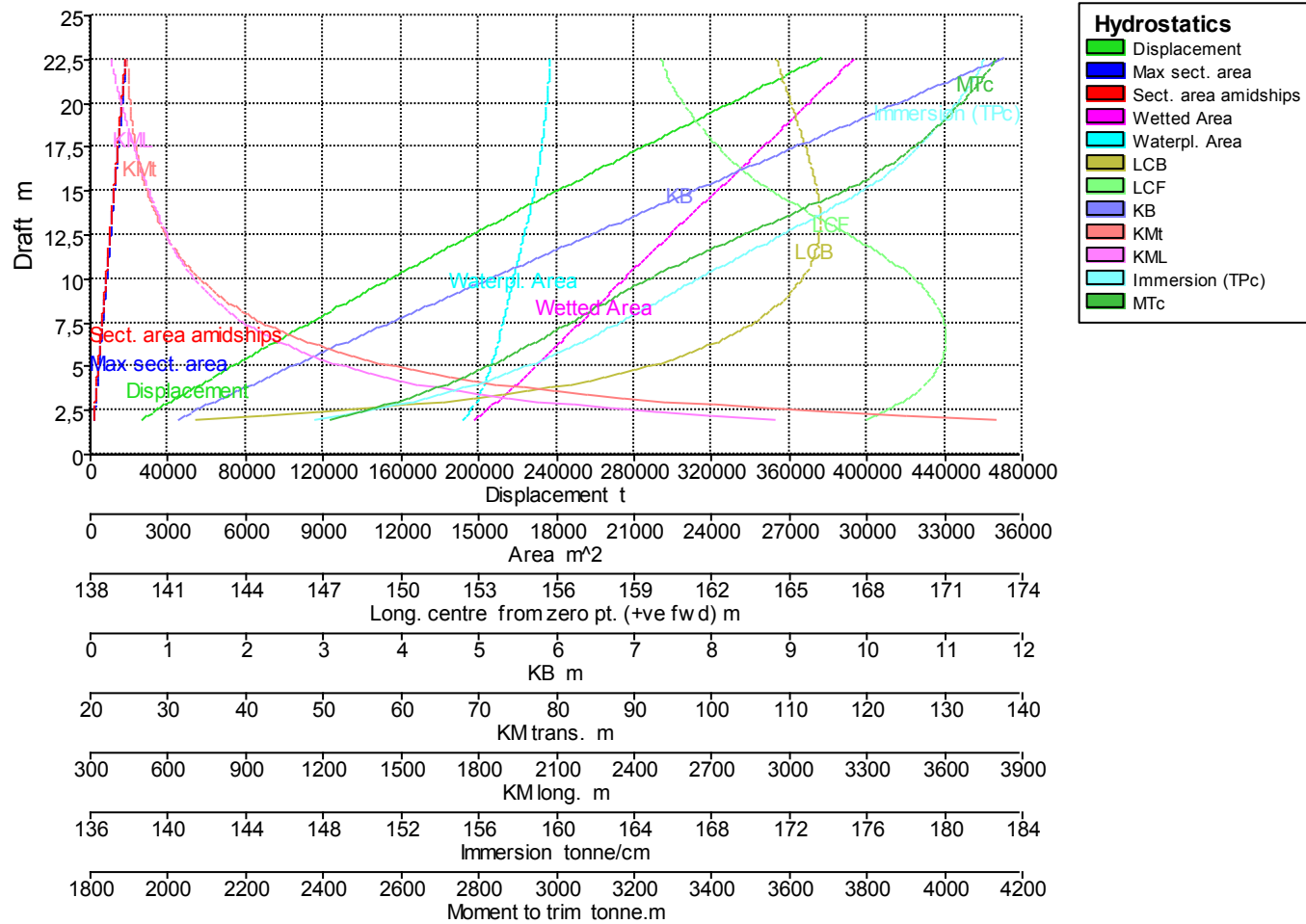

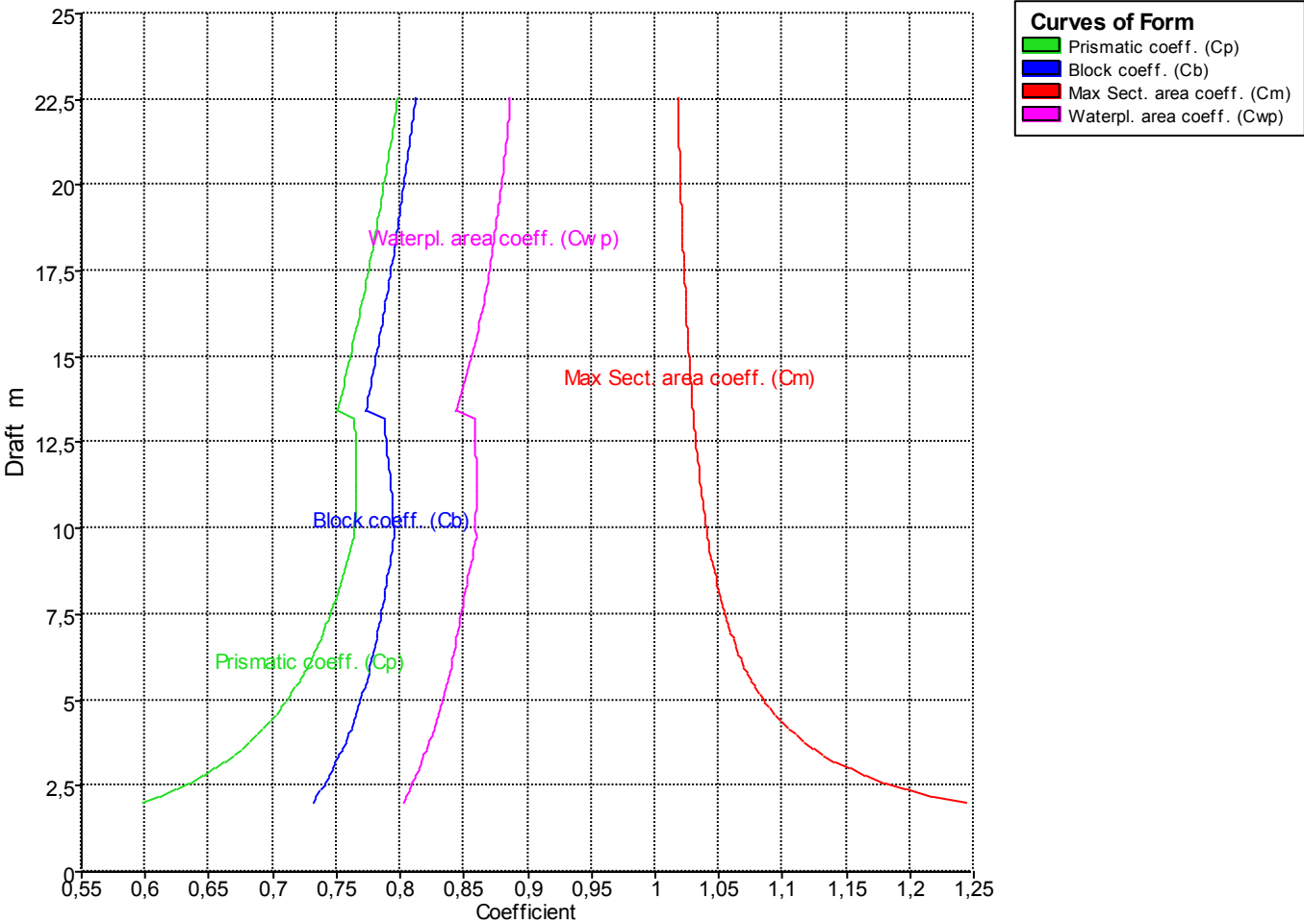

• **Para un trimado de 4.8 m:**

Draft Amidships m	Displacement t	Draft at LCF m	Trim (+ve by stern) m	WL Length m	Beam max extents on WL m	Wetted Area m ²	Waterpl. Area m ²	Block coeff. (Cb)	LCB from zero pt. (+ve fwd) m	LCF from zero pt. (+ve fwd) m	KB m	BMt m	BML m	KMt m	KML m	Immersion (TPc) tonne/cm	MTC tonne.m
2,000	26663	1,988	4,800	286,936	59,883	14495,906	14001,075	0,760	127,633	163,316	1,306	133,712	2714,963	135,003	2715,972	143,511	2209,999
2,200	29568	2,158	4,800	295,505	59,955	14848,922	14292,654	0,743	131,260	165,356	1,381	123,218	2598,114	124,585	2599,211	146,500	2344,557
2,400	32516	2,345	4,800	298,656	59,989	15078,639	14453,622	0,739	134,397	166,207	1,460	113,946	2429,987	115,393	2431,182	148,150	2410,232
2,600	35493	2,536	4,800	300,147	60,000	15276,866	14581,352	0,740	137,095	166,833	1,542	105,844	2274,807	107,374	2276,101	149,459	2461,548
2,800	38493	2,729	4,800	301,638	60,000	15456,492	14684,950	0,741	139,433	167,283	1,627	98,764	2133,038	100,380	2134,432	150,521	2501,858
3,000	41514	2,924	4,800	302,693	60,000	15627,034	14778,261	0,743	141,476	167,657	1,714	92,573	2007,724	94,278	2009,219	151,477	2538,264
3,200	44552	3,119	4,800	303,329	60,000	15791,713	14862,530	0,746	143,272	167,963	1,803	87,118	1896,030	88,912	1897,626	152,341	2571,063
3,400	47607	3,315	4,800	303,965	60,000	15953,613	14941,667	0,749	144,866	168,240	1,894	82,272	1797,024	84,157	1798,722	153,152	2602,502
3,600	50678	3,512	4,800	304,602	60,000	16112,473	15015,460	0,751	146,291	168,483	1,986	77,934	1708,362	79,912	1710,162	153,908	2632,297
3,800	53764	3,709	4,800	305,238	60,000	16267,419	15083,123	0,754	147,573	168,693	2,079	74,021	1628,018	76,092	1629,920	154,602	2659,853
4,000	56863	3,906	4,800	305,874	60,000	16418,759	15144,954	0,756	148,732	168,891	2,174	70,463	1554,864	72,629	1556,868	155,236	2685,394
4,200	59974	4,103	4,800	306,493	60,000	16567,778	15204,559	0,758	149,785	169,085	2,269	67,233	1488,773	69,494	1490,879	155,847	2710,565
4,400	63097	4,300	4,800	306,899	60,000	16714,980	15260,191	0,760	150,744	169,247	2,364	64,293	1427,975	66,650	1430,183	156,417	2733,862
4,600	66230	4,498	4,800	307,305	60,000	16861,122	15313,895	0,762	151,623	169,391	2,461	61,603	1372,400	64,057	1374,711	156,967	2756,609
4,800	69375	4,696	4,800	307,711	60,000	17006,557	15366,146	0,764	152,431	169,521	2,557	59,135	1321,474	61,686	1323,887	157,503	2779,019
5,000	72530	4,895	4,800	308,120	60,000	17150,936	15416,532	0,766	153,178	169,633	2,655	56,861	1274,479	59,510	1276,995	158,019	2800,779
5,200	75696	5,093	4,800	308,573	60,000	17294,586	15465,163	0,767	153,869	169,731	2,753	54,760	1230,939	57,507	1233,558	158,518	2821,868
5,400	78872	5,292	4,800	309,025	60,000	17437,946	15513,035	0,769	154,511	169,820	2,851	52,813	1190,711	55,658	1193,432	159,009	2842,895
5,600	82058	5,491	4,800	309,478	60,000	17580,143	15559,249	0,770	155,109	169,886	2,950	51,003	1153,214	53,947	1156,038	159,482	2863,321
5,800	85253	5,690	4,800	309,931	60,000	17722,254	15604,668	0,771	155,666	169,942	3,049	49,313	1118,396	52,356	1121,322	159,948	2883,774
6,000	88457	5,889	4,800	310,330	60,000	17862,873	15648,086	0,772	156,186	170,005	3,148	47,721	1085,855	50,864	1088,884	160,393	2903,877
6,200	91669	6,088	4,800	310,664	60,000	18002,337	15687,953	0,774	156,671	170,060	3,247	46,221	1054,913	49,463	1058,045	160,802	2922,339
6,400	94889	6,288	4,800	310,999	60,000	18141,838	15727,537	0,775	157,126	170,103	3,347	44,814	1026,019	48,156	1029,254	161,207	2940,937
6,600	98117	6,487	4,800	311,334	60,000	18281,075	15766,498	0,776	157,553	170,130	3,447	43,493	998,879	46,935	1002,218	161,607	2959,370
6,800	101353	6,687	4,800	311,669	60,000	18420,186	15804,812	0,778	157,955	170,150	3,548	42,249	973,334	45,792	976,775	161,999	2977,637
7,000	104596	6,887	4,800	312,003	60,000	18558,791	15842,023	0,779	158,333	170,158	3,648	41,075	949,142	44,718	952,686	162,381	2995,417
7,200	107848	7,087	4,800	312,338	60,000	18697,861	15879,573	0,780	158,690	170,152	3,749	39,967	926,465	43,712	930,113	162,766	3013,634
7,400	111107	7,287	4,800	312,673	60,000	18836,880	15916,997	0,781	159,026	170,131	3,850	38,919	905,099	42,765	908,850	163,149	3032,025
7,600	114374	7,488	4,800	313,008	60,000	18975,711	15954,072	0,782	159,343	170,099	3,951	37,927	884,877	41,873	888,731	163,529	3050,386
7,800	117649	7,688	4,800	313,328	60,000	19114,215	15990,230	0,783	159,642	170,052	4,052	36,985	865,605	41,033	869,563	163,900	3068,341
8,000	120931	7,889	4,800	313,580	60,000	19253,245	16026,733	0,784	159,925	169,995	4,153	36,091	847,417	40,240	851,478	164,274	3086,660
8,200	124221	8,090	4,800	313,832	60,000	19391,971	16062,288	0,785	160,191	169,929	4,255	35,240	830,021	39,491	834,186	164,638	3104,547
8,400	127518	8,291	4,800	314,084	60,000	19530,710	16097,718	0,786	160,443	169,861	4,357	34,430	813,479	38,783	817,747	165,002	3122,463

PETROLERO VLCC DE 300.000 TPM

CUADERNO IV: COMPARTIMENTADO Y CÁLCULOS DE ARQUITECTURA NAVAL

PEDRO LEMOS GONZÁLEZ

Draft Amidships m	Displacement t	Draft at LCF m	Trim (+ve by stern) m	WL Length m	Beam max extents on WL m	Wetted Area m ²	Waterpl. Area m ²	Block coeff. (Cb)	LCB from zero pt. (+ve fwd) m	LCF from zero pt. (+ve fwd) m	KB m	BMt m	BML m	KMt m	KML m	Immersion (TPc) tonne/cm	MTc tonne.m
8,600	130823	8,493	4,800	314,337	60,000	19669,952	16133,715	0,787	160,681	169,775	4,459	33,657	797,890	38,112	802,262	165,371	3141,060
8,800	134136	8,694	4,800	314,589	60,000	19809,409	16169,602	0,788	160,906	169,679	4,561	32,917	783,083	37,475	787,559	165,738	3159,916
9,000	137456	8,895	4,800	314,941	60,000	19948,935	16204,895	0,789	161,119	169,582	4,663	32,208	768,913	36,868	773,493	166,100	3178,642
9,200	140783	9,097	4,800	315,654	60,000	20061,608	16238,985	0,788	161,319	169,479	4,766	31,528	755,224	36,291	759,907	166,450	3196,739
9,400	144115	9,299	4,800	316,367	60,000	20200,930	16275,150	0,788	161,507	169,368	4,868	30,878	742,541	35,743	747,328	166,820	3216,633
9,600	147455	9,501	4,800	317,070	60,000	20341,655	16311,416	0,788	161,683	169,218	4,971	30,254	730,468	35,222	735,359	167,192	3236,879
9,800	150802	9,703	4,800	317,714	60,000	20483,027	16347,982	0,788	161,849	169,055	5,074	29,657	718,970	34,727	723,965	167,567	3257,494
10,000	154157	9,906	4,800	318,359	60,000	20624,816	16384,946	0,787	162,003	168,882	5,177	29,084	708,026	34,257	713,126	167,946	3278,558
10,200	157520	10,108	4,800	319,004	60,000	20766,997	16422,250	0,787	162,148	168,701	5,280	28,533	697,594	33,810	702,798	168,328	3300,021
10,400	160890	10,311	4,800	319,648	60,000	20909,671	16457,829	0,787	162,283	168,531	5,383	28,005	687,294	33,385	692,603	168,693	3320,156
10,600	164267	10,514	4,800	320,384	60,000	21054,178	16496,168	0,787	162,410	168,327	5,487	27,497	677,860	32,981	683,273	169,086	3342,702
10,800	167653	10,717	4,800	321,174	60,000	21199,117	16534,616	0,786	162,527	168,116	5,590	27,008	668,813	32,596	674,331	169,480	3365,466
11,000	171046	10,920	4,800	321,964	60,000	21344,124	16572,688	0,785	162,636	167,901	5,694	26,537	660,065	32,228	665,687	169,870	3388,097
11,200	174447	11,123	4,800	322,755	60,000	21488,682	16609,523	0,785	162,737	167,686	5,798	26,081	651,495	31,877	657,222	170,248	3410,030
11,400	177855	11,326	4,800	323,502	60,000	21630,743	16642,328	0,784	162,830	167,499	5,902	25,641	642,644	31,540	648,476	170,584	3428,791
11,600	181271	11,530	4,800	324,237	60,000	21777,188	16679,852	0,784	162,916	167,261	6,006	25,215	634,868	31,218	640,805	170,968	3451,855
11,800	184694	11,733	4,800	324,972	60,000	21922,231	16715,254	0,783	162,994	167,042	6,111	24,803	627,060	30,911	633,102	171,331	3473,260
12,000	188124	11,936	4,800	325,707	60,000	22066,825	16751,127	0,783	163,066	166,817	6,215	24,405	619,614	30,617	625,762	171,699	3495,276
12,200	191561	12,140	4,800	326,442	60,000	22213,502	16787,783	0,782	163,131	166,578	6,319	24,020	612,552	30,337	618,805	172,075	3518,132
12,400	195006	12,343	4,800	327,177	60,000	22358,082	16821,582	0,782	163,190	166,365	6,424	23,647	605,313	30,069	611,672	172,421	3538,599
12,600	198457	12,546	4,800	333,784	60,000	22505,377	16857,979	0,767	163,243	166,122	6,529	23,287	598,699	29,813	605,162	172,794	3561,488
12,800	201917	12,750	4,800	333,821	60,000	22652,937	16894,310	0,768	163,291	165,875	6,634	22,939	592,297	29,570	598,867	173,167	3584,453
13,000	205383	12,954	4,800	333,858	60,000	22800,420	16930,082	0,769	163,332	165,628	6,739	22,601	586,027	29,338	592,702	173,533	3607,036
13,200	208857	13,157	4,800	333,870	60,000	22947,421	16964,452	0,771	163,368	165,385	6,844	22,272	579,820	29,114	586,600	173,886	3628,830
13,400	212337	13,360	4,800	333,880	60,000	23089,136	16991,856	0,772	163,400	165,206	6,949	21,949	572,935	28,896	579,822	174,167	3645,005
13,600	215824	13,564	4,800	333,890	60,000	23238,451	17027,030	0,773	163,427	164,947	7,054	21,634	567,376	28,686	574,369	174,527	3668,643
13,800	219317	13,767	4,800	333,901	60,000	23386,505	17060,433	0,774	163,449	164,702	7,160	21,326	561,788	28,484	568,887	174,869	3691,031
14,000	222817	13,971	4,800	333,911	60,000	23533,883	17092,674	0,775	163,467	164,467	7,265	21,027	556,238	28,290	563,442	175,200	3712,606
14,200	226324	14,173	4,800	333,922	60,000	23673,757	17116,151	0,776	163,481	164,318	7,371	20,737	549,700	28,105	557,010	175,441	3726,241
14,400	229836	14,377	4,800	333,932	60,000	23822,421	17148,556	0,777	163,492	164,077	7,476	20,454	544,545	27,928	551,962	175,773	3748,355
14,600	233354	14,580	4,800	333,943	60,000	23968,807	17177,814	0,778	163,499	163,866	7,582	20,179	539,132	27,759	546,655	176,073	3767,625
14,800	236878	14,783	4,800	333,953	60,000	24113,421	17204,580	0,779	163,504	163,678	7,687	19,912	533,564	27,597	541,193	176,347	3784,706
15,000	240407	14,985	4,800	333,963	60,000	24257,113	17229,861	0,780	163,505	163,502	7,793	19,652	527,970	27,443	535,705	176,606	3800,491
15,200	243941	15,188	4,800	333,971	60,000	24400,552	17254,446	0,781	163,503	163,328	7,899	19,400	522,447	27,297	530,288	176,858	3815,700
15,400	247480	15,390	4,800	333,972	60,000	24543,690	17278,427	0,782	163,500	163,160	8,004	19,155	517,002	27,157	524,950	177,104	3830,408
15,600	251024	15,593	4,800	333,973	60,000	24686,659	17301,679	0,783	163,494	162,996	8,110	18,915	511,654	27,023	519,708	177,342	3844,770
15,800	254573	15,795	4,800	333,974	60,000	24829,275	17323,724	0,784	163,486	162,841	8,216	18,678	506,372	26,892	514,533	177,568	3858,579
16,000	258126	15,997	4,800	333,976	60,000	24971,408	17344,647	0,785	163,476	162,694	8,322	18,445	501,146	26,765	509,413	177,783	3871,766

PETROLERO VLCC DE 300.000 TPM

CUADERNO IV: COMPARTIMENTADO Y CÁLCULOS DE ARQUITECTURA NAVAL

PEDRO LEMOS GONZÁLEZ

Draft Amidships m	Displacement t	Draft at LCF m	Trim (+ve by stern) m	WL Length m	Beam max extents on WL m	Wetted Area m ²	Waterpl. Area m ²	Block coeff. (Cb)	LCB from zero pt. (+ve fwd) m	LCF from zero pt. (+ve fwd) m	KB m	BMt m	BML m	KMt m	KML m	Immersion (TPc) tonne/cm	MTc tonne.m
16,200	261684	16,199	4,800	333,977	60,000	25113,197	17364,761	0,786	163,464	162,553	8,427	18,218	495,994	26,643	504,367	177,989	3884,486
16,400	265245	16,401	4,800	333,978	60,000	25254,628	17384,118	0,787	163,451	162,418	8,533	17,995	490,916	26,526	499,395	178,187	3896,770
16,600	268810	16,603	4,800	333,979	60,000	25395,727	17402,768	0,788	163,437	162,289	8,639	17,778	485,909	26,414	494,495	178,378	3908,612
16,800	272379	16,805	4,800	333,980	60,000	25536,527	17420,803	0,789	163,421	162,164	8,745	17,565	480,977	26,307	489,670	178,563	3920,059
17,000	275952	17,007	4,800	333,982	60,000	25677,004	17438,192	0,790	163,404	162,044	8,850	17,357	476,113	26,205	484,912	178,741	3931,072
17,200	279528	17,208	4,800	333,983	60,000	25817,257	17455,090	0,791	163,386	161,928	8,956	17,154	471,327	26,108	480,232	178,915	3941,759
17,400	283108	17,410	4,800	333,984	60,000	25957,319	17471,536	0,792	163,366	161,814	9,062	16,956	466,619	26,016	475,630	179,083	3952,141
17,600	286691	17,612	4,800	333,985	60,000	26097,170	17487,505	0,793	163,346	161,704	9,167	16,762	461,980	25,928	471,097	179,247	3962,168
17,800	290277	17,813	4,800	333,986	60,000	26236,797	17503,008	0,794	163,325	161,597	9,273	16,573	457,411	25,844	466,634	179,406	3971,860
18,000	293866	18,015	4,800	333,986	60,000	26376,404	17518,384	0,795	163,304	161,491	9,378	16,389	452,936	25,766	462,265	179,563	3981,462
18,200	297459	18,216	4,800	333,986	60,000	26515,827	17533,374	0,796	163,281	161,388	9,484	16,209	448,531	25,691	457,966	179,717	3990,774
18,400	301054	18,418	4,800	333,986	60,000	26655,289	17548,349	0,797	163,258	161,286	9,589	16,033	444,223	25,621	453,764	179,871	4000,086
18,600	304653	18,619	4,800	333,986	60,000	26794,627	17563,027	0,797	163,234	161,187	9,695	15,861	439,987	25,554	449,634	180,021	4009,173
18,800	308254	18,821	4,800	333,986	60,000	26933,901	17577,507	0,798	163,210	161,089	9,800	15,693	435,827	25,492	445,580	180,169	4018,111
19,000	311859	19,022	4,800	333,986	60,000	27073,084	17591,729	0,799	163,184	160,994	9,906	15,529	431,736	25,433	441,595	180,315	4026,846
19,200	315466	19,224	4,800	333,986	60,000	27212,295	17605,915	0,800	163,159	160,899	10,011	15,369	427,730	25,378	437,695	180,461	4035,565
19,400	319076	19,425	4,800	333,986	60,000	27351,436	17619,856	0,801	163,133	160,806	10,117	15,212	423,789	25,327	433,859	180,604	4044,085
19,600	322689	19,626	4,800	333,986	60,000	27490,582	17633,715	0,802	163,106	160,714	10,222	15,059	419,924	25,279	430,100	180,746	4052,547
19,800	326305	19,828	4,800	333,986	60,000	27629,697	17647,275	0,802	163,079	160,625	10,327	14,908	416,122	25,234	426,404	180,885	4060,842
20,000	329924	20,029	4,800	333,986	60,000	27768,690	17659,892	0,803	163,052	160,541	10,433	14,759	412,361	25,190	422,749	181,014	4068,755
20,200	333545	20,230	4,800	333,986	60,000	27907,527	17671,767	0,804	163,024	160,462	10,538	14,612	408,642	25,148	419,136	181,136	4076,324
20,400	337169	20,431	4,800	333,986	60,000	28046,198	17683,031	0,805	162,996	160,387	10,643	14,466	404,968	25,108	415,567	181,251	4083,581
20,600	340794	20,632	4,800	333,986	60,000	28184,693	17693,749	0,805	162,968	160,317	10,748	14,323	401,339	25,070	412,044	181,361	4090,536
20,800	344422	20,833	4,800	333,986	60,000	28323,009	17703,958	0,806	162,940	160,252	10,854	14,183	397,753	25,035	408,564	181,466	4097,191
21,000	348052	21,034	4,800	333,986	60,000	28461,108	17713,609	0,807	162,911	160,191	10,959	14,045	394,205	25,002	405,121	181,564	4103,496
21,200	351684	21,235	4,800	333,986	60,000	28598,927	17722,573	0,808	162,883	160,136	11,064	13,909	390,684	24,971	401,705	181,656	4109,341
21,400	355318	21,436	4,800	333,986	60,000	28736,580	17731,099	0,808	162,855	160,086	11,169	13,775	387,203	24,943	398,329	181,744	4114,884
21,600	358953	21,636	4,800	333,986	60,000	28874,157	17739,201	0,809	162,826	160,039	11,274	13,645	383,761	24,917	394,993	181,827	4120,123
21,800	362590	21,837	4,800	333,986	60,000	29011,692	17747,033	0,810	162,798	159,995	11,379	13,516	380,366	24,894	391,703	181,907	4125,161
22,000	366228	22,038	4,800	333,986	60,000	29149,121	17754,504	0,810	162,770	159,955	11,484	13,391	377,010	24,873	388,453	181,984	4129,917
22,200	369868	22,238	4,800	333,986	60,000	29286,511	17761,814	0,811	162,742	159,918	11,589	13,267	373,705	24,854	385,253	182,059	4134,539
22,400	373510	22,439	4,800	333,986	60,000	29423,869	17769,054	0,812	162,715	159,886	11,693	13,146	370,454	24,838	382,108	182,133	4139,090
22,600	377153	22,639	4,800	333,986	60,000	29561,226	17776,331	0,812	162,687	159,856	11,798	13,028	367,266	24,825	379,024	182,207	4143,668

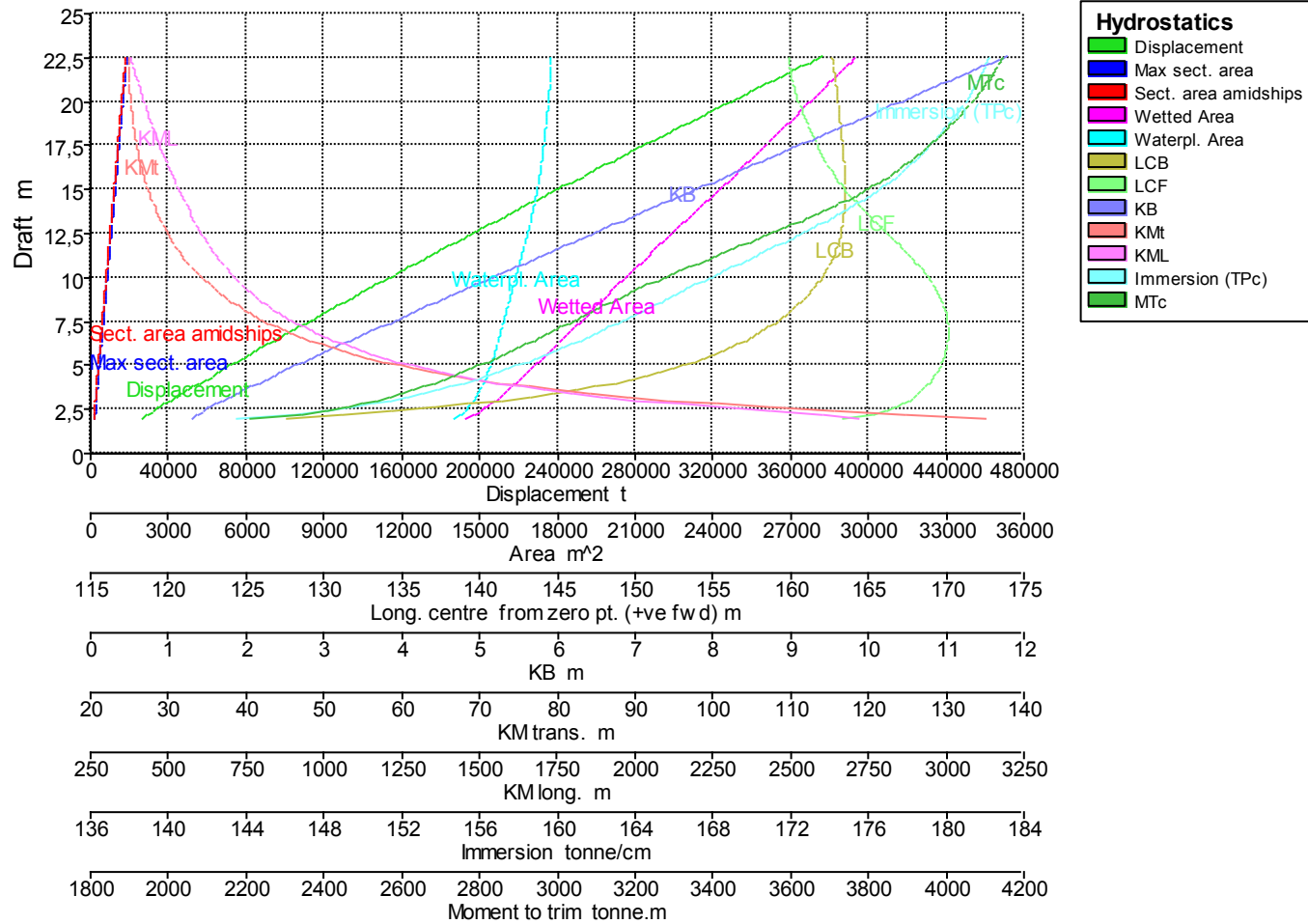

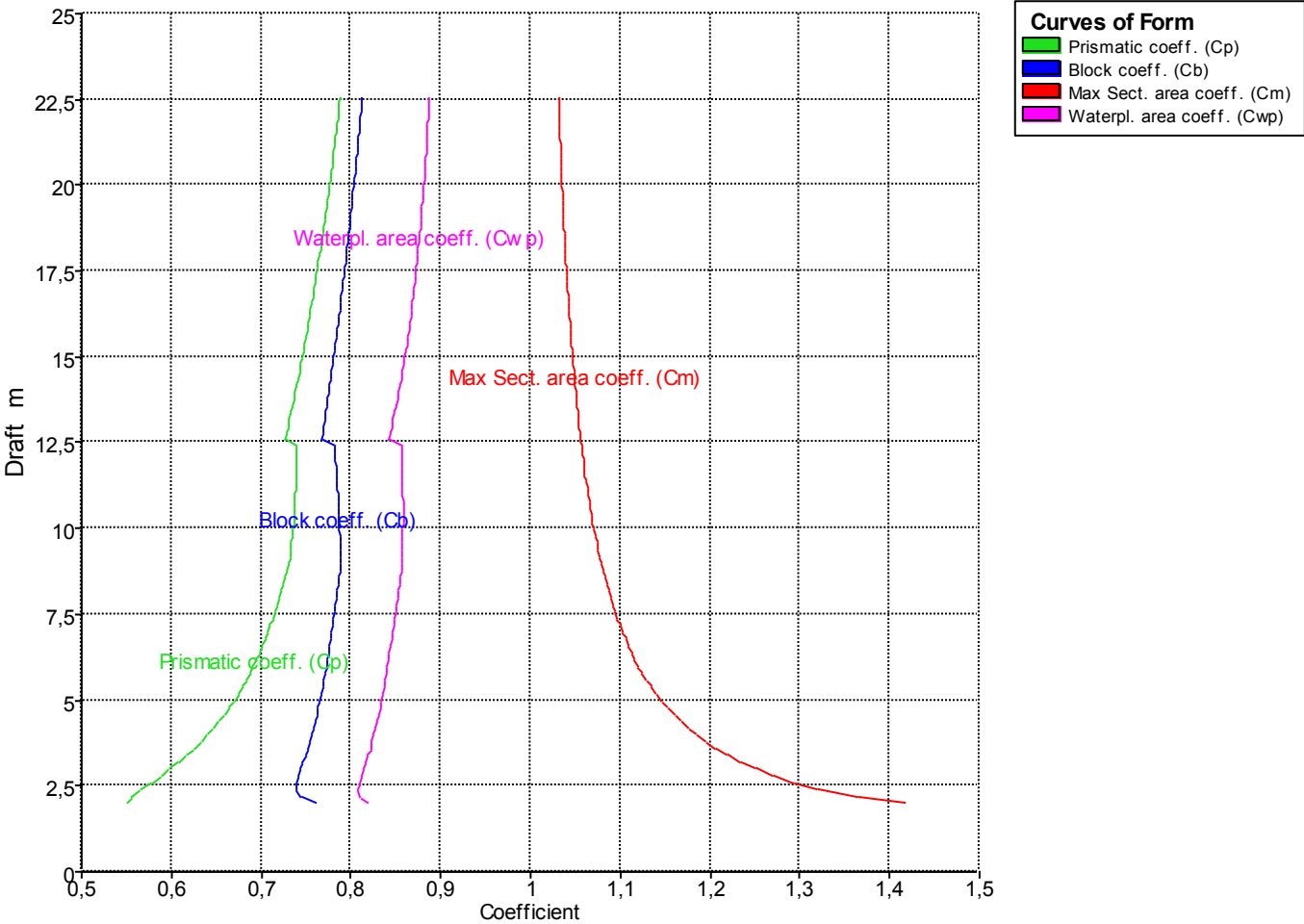

- **Para un trimado de -1,6 m:**

Draft Amidships m	Displacement t	Draft at LCF m	Trim (+ve by stern) m	WL Length m	Beam max extents on WL m	Wetted Area m ²	Waterpl. Area m ²	Block coeff. (Cb)	LCB from zero pt. (+ve fwd) m	LCF from zero pt. (+ve fwd) m	KB m	BMt m	BML m	KMt m	KML m	Immersion (TPc) tonne/cm	MTC tonne.m
2,000	28832	2,056	-1,600	306,751	59,790	15040,747	14627,063	0,769	185,790	173,911	1,095	129,008	2869,883	130,101	2870,944	149,927	2527,296
2,200	31841	2,256	-1,600	307,212	59,881	15205,315	14724,100	0,769	184,667	173,879	1,196	118,413	2632,676	119,607	2633,839	150,922	2558,790
2,400	34870	2,456	-1,600	307,672	59,953	15367,698	14815,481	0,770	183,731	173,844	1,296	109,488	2434,071	110,783	2435,338	151,859	2589,222
2,600	37917	2,656	-1,600	308,133	59,989	15521,240	14898,516	0,770	182,938	173,813	1,398	101,827	2264,122	103,224	2265,492	152,710	2617,331
2,800	40980	2,856	-1,600	308,559	60,000	15674,334	14970,975	0,771	182,260	173,793	1,499	95,101	2116,735	96,599	2118,209	153,452	2643,057
3,000	44056	3,055	-1,600	308,855	60,000	15825,387	15037,968	0,773	181,668	173,767	1,601	89,205	1988,446	90,805	1990,023	154,139	2667,683
3,200	47145	3,255	-1,600	309,149	60,000	15974,918	15100,761	0,775	181,149	173,740	1,703	83,993	1875,869	85,695	1877,549	154,783	2691,592
3,400	50247	3,455	-1,600	309,442	60,000	16121,258	15157,922	0,777	180,691	173,733	1,805	79,336	1775,645	81,140	1777,429	155,369	2713,879
3,600	53360	3,655	-1,600	309,735	60,000	16265,269	15210,975	0,778	180,286	173,731	1,907	75,167	1685,837	77,073	1687,724	155,912	2734,731
3,800	56483	3,855	-1,600	310,028	60,000	16408,515	15261,927	0,780	179,923	173,724	2,009	71,425	1605,262	73,433	1607,252	156,435	2754,963
4,000	59617	4,055	-1,600	310,321	60,000	16550,816	15310,494	0,781	179,597	173,711	2,112	68,042	1532,441	70,153	1534,534	156,933	2774,428
4,200	62761	4,255	-1,600	310,614	60,000	16692,101	15356,695	0,782	179,303	173,696	2,214	64,967	1466,268	67,181	1468,464	157,406	2793,139
4,400	65914	4,455	-1,600	310,907	60,000	16832,250	15400,619	0,783	179,035	173,680	2,317	62,158	1405,832	64,474	1408,132	157,856	2811,103
4,600	69076	4,655	-1,600	311,200	60,000	16970,730	15441,575	0,785	178,790	173,662	2,419	59,580	1350,167	61,998	1352,570	158,276	2827,859
4,800	72246	4,855	-1,600	311,415	60,000	17108,405	15481,008	0,786	178,566	173,642	2,522	57,213	1298,935	59,734	1301,440	158,680	2843,986
5,000	75424	5,055	-1,600	311,623	60,000	17245,678	15519,254	0,787	178,360	173,619	2,624	55,030	1251,727	57,654	1254,336	159,072	2859,783
5,200	78610	5,255	-1,600	311,830	60,000	17382,558	15556,211	0,788	178,168	173,594	2,727	53,009	1208,057	55,735	1210,769	159,451	2875,213
5,400	81804	5,454	-1,600	312,038	60,000	17518,869	15591,505	0,789	177,991	173,567	2,829	51,129	1167,438	53,958	1170,253	159,813	2890,044
5,600	85005	5,654	-1,600	312,246	60,000	17654,678	15625,349	0,790	177,826	173,539	2,932	49,377	1129,588	52,309	1132,506	160,160	2904,404
5,800	88213	5,854	-1,600	312,454	60,000	17790,029	15657,769	0,791	177,672	173,509	3,035	47,739	1094,214	50,774	1097,235	160,492	2918,278
6,000	91427	6,054	-1,600	312,662	60,000	17924,736	15688,730	0,792	177,527	173,481	3,137	46,205	1061,042	49,342	1064,166	160,809	2931,597
6,200	94647	6,254	-1,600	312,870	60,000	18058,652	15717,838	0,793	177,390	173,443	3,240	44,768	1029,730	48,007	1032,957	161,108	2943,942
6,400	97872	6,454	-1,600	313,076	60,000	18192,033	15746,089	0,794	177,259	173,402	3,343	43,419	1000,300	46,761	1003,630	161,397	2955,941
6,600	101103	6,653	-1,600	313,213	60,000	18325,099	15773,626	0,795	177,135	173,352	3,445	42,152	972,578	45,597	976,012	161,680	2967,601
6,800	104339	6,853	-1,600	313,351	60,000	18458,195	15800,824	0,796	177,016	173,297	3,548	40,959	946,498	44,507	950,035	161,958	2979,201
7,000	107581	7,053	-1,600	313,489	60,000	18591,377	15827,791	0,797	176,903	173,240	3,651	39,835	921,925	43,486	925,564	162,235	2990,768
7,200	110828	7,253	-1,600	313,626	60,000	18724,443	15853,933	0,798	176,795	173,178	3,753	38,772	898,647	42,525	902,389	162,503	3002,020
7,400	114081	7,452	-1,600	313,764	60,000	18857,607	15879,779	0,799	176,691	173,114	3,856	37,764	876,658	41,620	880,504	162,768	3013,307
7,600	117339	7,652	-1,600	313,902	60,000	18990,731	15904,945	0,800	176,591	173,045	3,959	36,806	855,805	40,765	859,753	163,026	3024,445
7,800	120602	7,852	-1,600	314,039	60,000	19123,594	15929,038	0,801	176,494	172,975	4,061	35,894	835,927	39,955	839,978	163,273	3035,173
8,000	123870	8,051	-1,600	314,181	60,000	19256,173	15952,145	0,801	176,400	172,903	4,164	35,024	816,959	39,187	821,113	163,509	3045,515
8,200	127143	8,251	-1,600	314,325	60,000	19388,220	15973,880	0,802	176,309	172,828	4,267	34,194	798,746	38,460	803,003	163,732	3055,130
8,400	130420	8,450	-1,600	314,453	60,000	19520,421	15995,734	0,803	176,221	172,745	4,369	33,403	781,478	37,772	785,838	163,956	3064,992
8,600	133702	8,650	-1,600	314,581	60,000	19652,740	16017,791	0,804	176,134	172,659	4,472	32,650	765,080	37,121	769,543	164,182	3075,081
8,800	136988	8,850	-1,600	314,709	60,000	19783,945	16039,555	0,804	176,050	172,569	4,575	31,931	749,406	36,505	753,972	164,405	3085,027

PETROLERO VLCC DE 300.000 TPM

CUADERNO IV: COMPARTIMENTADO Y CÁLCULOS DE ARQUITECTURA NAVAL

PEDRO LEMOS GONZÁLEZ

Draft Amidships m	Displacement t	Draft at LCF m	Trim (+ve by stern) m	WL Length m	Beam max extents on WL m	Wetted Area m ²	Waterpl. Area m ²	Block coeff. (Cb)	LCB from zero pt. (+ve fwd) m	LCF from zero pt. (+ve fwd) m	KB m	BMt m	BML m	KMt m	KML m	Immersion (TPc) tonne/cm	MTc tonne.m
9,000	140278	9,049	-1,600	314,837	60,000	19916,425	16061,508	0,805	175,967	172,476	4,677	31,246	734,475	35,922	739,143	164,630	3095,127
9,200	143573	9,249	-1,600	314,965	60,000	20049,243	16083,823	0,806	175,886	172,376	4,780	30,591	720,271	35,370	725,042	164,859	3105,535
9,400	146873	9,448	-1,600	315,093	60,000	20182,436	16106,556	0,806	175,806	172,269	4,883	29,965	706,750	34,847	711,624	165,092	3116,268
9,600	150177	9,648	-1,600	315,220	60,000	20315,666	16129,020	0,807	175,726	172,159	4,985	29,365	693,768	34,350	698,745	165,322	3126,866
9,800	153486	9,847	-1,600	315,348	60,000	20449,253	16151,671	0,808	175,648	172,042	5,088	28,791	681,351	33,879	686,431	165,555	3137,607
10,000	156800	10,046	-1,600	315,452	60,000	20583,148	16174,279	0,808	175,570	171,914	5,191	28,241	669,435	33,431	674,618	165,786	3148,350
10,200	160118	10,246	-1,600	315,553	60,000	20717,431	16197,327	0,809	175,493	171,781	5,293	27,713	658,057	33,006	663,342	166,023	3159,426
10,400	163441	10,445	-1,600	315,654	60,000	20851,872	16221,040	0,810	175,416	171,641	5,396	27,206	647,227	32,602	652,615	166,266	3171,049
10,600	166769	10,644	-1,600	315,756	60,000	20986,656	16245,037	0,810	175,339	171,497	5,499	26,719	636,851	32,218	642,342	166,512	3182,904
10,800	170101	10,844	-1,600	315,857	60,000	21121,889	16268,686	0,811	175,262	171,351	5,602	26,246	626,906	31,847	632,500	166,754	3195,006
11,000	173439	11,043	-1,600	315,958	60,000	21257,020	16291,884	0,811	175,185	171,207	5,705	25,788	617,289	31,492	622,986	166,992	3206,924
11,200	176782	11,242	-1,600	316,059	60,000	21392,333	16315,187	0,812	175,108	171,062	5,807	25,348	608,031	31,155	613,831	167,231	3218,927
11,400	180129	11,441	-1,600	316,161	60,000	21527,977	16338,786	0,813	175,032	170,912	5,910	24,924	599,135	30,834	605,038	167,473	3231,144
11,600	183481	11,641	-1,600	316,262	60,000	21664,396	16363,982	0,813	174,955	170,746	6,013	24,515	590,768	30,528	596,774	167,731	3244,620
11,800	186839	11,840	-1,600	316,363	60,000	21801,238	16389,457	0,814	174,877	170,574	6,116	24,121	582,718	30,237	588,827	167,992	3258,311
12,000	190201	12,039	-1,600	316,466	60,000	21938,502	16415,052	0,814	174,799	170,397	6,219	23,740	574,950	29,959	581,162	168,254	3272,101
12,200	193569	12,238	-1,600	317,011	60,000	22049,518	16440,515	0,814	174,721	170,219	6,322	23,373	567,415	29,695	573,730	168,515	3285,776
12,400	196942	12,437	-1,600	317,536	60,000	22186,662	16467,107	0,813	174,642	170,029	6,425	23,019	560,271	29,444	566,689	168,788	3300,365
12,600	200321	12,636	-1,600	318,061	60,000	22325,858	16495,892	0,813	174,563	169,819	6,528	22,676	553,630	29,204	560,151	169,083	3316,689
12,800	203706	12,835	-1,600	318,586	60,000	22465,750	16525,303	0,812	174,482	169,602	6,632	22,345	547,270	28,976	553,895	169,384	3333,520
13,000	207096	13,034	-1,600	319,112	60,000	22606,106	16555,439	0,812	174,400	169,379	6,735	22,024	541,191	28,759	547,919	169,693	3350,930
13,200	210494	13,233	-1,600	319,637	60,000	22746,866	16586,113	0,811	174,317	169,150	6,838	21,714	535,362	28,552	542,194	170,008	3368,818
13,400	213897	13,432	-1,600	320,162	60,000	22887,456	16616,120	0,811	174,233	168,926	6,941	21,411	529,661	28,352	536,596	170,315	3386,454
13,600	217306	13,631	-1,600	320,694	60,000	23029,316	16645,104	0,810	174,148	168,711	7,045	21,116	524,028	28,160	531,067	170,612	3403,459
13,800	220722	13,829	-1,600	321,348	60,000	23172,196	16676,261	0,809	174,062	168,473	7,148	20,828	518,843	27,977	525,985	170,932	3422,437
14,000	224143	14,028	-1,600	322,003	60,000	23314,921	16707,025	0,808	173,975	168,239	7,252	20,549	513,764	27,801	521,010	171,247	3441,186
14,200	227572	14,227	-1,600	322,657	60,000	23458,016	16737,971	0,808	173,887	168,002	7,356	20,278	508,852	27,634	516,201	171,564	3460,151
14,400	231006	14,426	-1,600	323,311	60,000	23601,105	16768,681	0,807	173,797	167,765	7,459	20,015	504,049	27,474	511,502	171,879	3478,975
14,600	234447	14,625	-1,600	323,965	60,000	23742,269	16796,743	0,806	173,707	167,554	7,563	19,759	499,062	27,322	506,618	172,167	3495,562
14,800	237893	14,824	-1,600	324,618	60,000	23887,677	16829,302	0,805	173,616	167,298	7,667	19,511	494,735	27,178	502,395	172,500	3516,041
15,000	241347	15,022	-1,600	325,271	60,000	24031,444	16860,138	0,804	173,524	167,059	7,771	19,270	490,317	27,040	498,081	172,816	3535,044
15,200	244806	15,221	-1,600	325,925	60,000	24176,144	16891,711	0,804	173,431	166,813	7,875	19,036	486,099	26,910	493,967	173,140	3554,733
15,400	248272	15,420	-1,600	326,578	60,000	24321,552	16923,118	0,803	173,337	166,566	7,978	18,804	482,038	26,782	490,011	173,462	3574,841
15,600	251744	15,619	-1,600	327,231	60,000	24464,376	16951,176	0,802	173,242	166,349	8,083	18,576	477,759	26,658	485,836	173,750	3592,499
15,800	255222	15,818	-1,600	327,884	60,000	24609,588	16981,102	0,801	173,146	166,111	8,187	18,352	473,835	26,539	482,016	174,056	3612,137
16,000	258707	16,017	-1,600	333,954	60,000	24755,004	17010,887	0,787	173,050	165,874	8,291	18,134	470,017	26,424	478,302	174,362	3631,890
16,200	262197	16,215	-1,600	333,954	60,000	24900,410	17040,398	0,788	172,953	165,639	8,395	17,920	466,277	26,315	474,666	174,664	3651,558
16,400	265693	16,414	-1,600	333,954	60,000	25045,345	17069,145	0,789	172,855	165,411	8,499	17,711	462,555	26,210	471,049	174,959	3670,679

PETROLERO VLCC DE 300.000 TPM

CUADERNO IV: COMPARTIMENTADO Y CÁLCULOS DE ARQUITECTURA NAVAL

PEDRO LEMOS GONZÁLEZ

Draft Amidships m	Displacement t	Draft at LCF m	Trim (+ve by stern) m	WL Length m	Beam max extents on WL m	Wetted Area m ²	Waterpl. Area m ²	Block coeff. (Cb)	LCB from zero pt. (+ve fwd) m	LCF from zero pt. (+ve fwd) m	KB m	BMt m	BML m	KMt m	KML m	Immersion (TPc) tonne/cm	MTc tonne.m
16,600	269195	16,613	-1,600	333,954	60,000	25190,301	17097,663	0,790	172,757	165,186	8,603	17,508	458,906	26,111	467,504	175,251	3689,705
16,800	272702	16,812	-1,600	333,954	60,000	25331,858	17122,404	0,790	172,658	164,997	8,708	17,310	454,942	26,017	463,644	175,505	3705,392
17,000	276215	17,011	-1,600	333,954	60,000	25479,603	17153,396	0,791	172,559	164,746	8,812	17,116	451,744	25,928	460,551	175,822	3726,842
17,200	279734	17,210	-1,600	333,954	60,000	25625,980	17182,747	0,792	172,460	164,510	8,917	16,927	448,453	25,843	457,364	176,123	3746,899
17,400	283260	17,409	-1,600	333,954	60,000	25771,694	17211,111	0,793	172,359	164,284	9,021	16,742	445,136	25,763	454,152	176,414	3766,122
17,600	286790	17,608	-1,600	333,954	60,000	25911,099	17232,547	0,793	172,259	164,126	9,126	16,562	441,180	25,687	450,300	176,634	3779,085
17,800	290326	17,807	-1,600	333,954	60,000	26058,642	17261,541	0,794	172,158	163,891	9,230	16,383	438,139	25,613	447,364	176,931	3799,449
18,000	293867	18,006	-1,600	333,954	60,000	26203,720	17286,949	0,795	172,057	163,690	9,335	16,208	434,825	25,543	444,154	177,191	3816,771
18,200	297414	18,205	-1,600	333,954	60,000	26347,335	17310,194	0,796	171,957	163,511	9,439	16,036	431,382	25,475	440,816	177,429	3832,290
18,400	300964	18,404	-1,600	333,954	60,000	26489,925	17331,678	0,796	171,856	163,348	9,544	15,867	427,862	25,411	437,401	177,650	3846,420
18,600	304519	18,603	-1,600	333,954	60,000	26632,159	17352,379	0,797	171,756	163,192	9,649	15,702	424,359	25,350	434,002	177,862	3860,013
18,800	308079	18,803	-1,600	333,954	60,000	26774,084	17372,441	0,798	171,656	163,043	9,753	15,539	420,883	25,292	430,631	178,068	3873,175
19,000	311642	19,002	-1,600	333,954	60,000	26915,652	17391,837	0,799	171,557	162,899	9,858	15,380	417,433	25,237	427,286	178,266	3885,905
19,200	315209	19,201	-1,600	333,954	60,000	27057,047	17410,870	0,799	171,458	162,760	9,962	15,223	414,031	25,186	423,988	178,461	3898,405
19,400	318780	19,401	-1,600	333,954	60,000	27198,192	17429,572	0,800	171,360	162,628	10,067	15,070	410,675	25,137	420,737	178,653	3910,687
19,600	322355	19,600	-1,600	333,954	60,000	27339,034	17447,870	0,801	171,262	162,503	10,172	14,920	407,361	25,092	417,527	178,841	3922,710
19,800	325934	19,799	-1,600	333,954	60,000	27479,684	17465,813	0,801	171,165	162,381	10,276	14,773	404,087	25,050	414,359	179,025	3934,485
20,000	329516	19,999	-1,600	333,954	60,000	27620,184	17483,549	0,802	171,069	162,265	10,381	14,630	400,864	25,011	411,240	179,206	3946,112
20,200	333102	20,198	-1,600	333,958	60,000	27760,421	17500,953	0,803	170,974	162,154	10,486	14,489	397,679	24,975	408,160	179,385	3957,493
20,400	336692	20,398	-1,600	333,971	60,000	27897,927	17518,707	0,804	170,879	162,052	10,590	14,352	394,580	24,942	405,165	179,567	3969,118
20,600	340285	20,597	-1,600	333,985	60,000	28038,203	17537,129	0,804	170,786	161,960	10,695	14,218	391,589	24,912	402,279	179,756	3981,262
20,800	343882	20,797	-1,600	333,998	60,000	28178,405	17555,542	0,805	170,693	161,876	10,800	14,086	388,655	24,886	399,449	179,944	3993,409
21,000	347482	20,997	-1,600	334,012	60,000	28318,561	17573,823	0,806	170,601	161,793	10,904	13,958	385,765	24,862	396,665	180,132	4005,455
21,200	351087	21,196	-1,600	334,025	60,000	28458,647	17592,003	0,806	170,510	161,714	11,009	13,832	382,923	24,840	393,927	180,318	4017,431
21,400	354695	21,396	-1,600	334,039	60,000	28598,781	17610,372	0,807	170,420	161,641	11,114	13,708	380,146	24,822	391,255	180,506	4029,563
21,600	358307	21,595	-1,600	334,070	60,000	28739,006	17628,937	0,807	170,331	161,570	11,218	13,588	377,434	24,806	388,647	180,697	4041,853
21,800	361923	21,795	-1,600	334,126	60,000	28879,165	17647,313	0,808	170,244	161,504	11,323	13,469	374,759	24,792	386,077	180,885	4054,020
22,000	365542	21,995	-1,600	334,182	60,000	29019,342	17665,381	0,808	170,157	161,442	11,428	13,353	372,121	24,780	383,544	181,070	4066,085
22,200	369166	22,195	-1,600	334,238	60,000	29159,553	17683,088	0,809	170,071	161,386	11,532	13,237	369,520	24,770	381,048	181,252	4078,030
22,400	372792	22,394	-1,600	334,294	60,000	29299,701	17700,274	0,809	169,986	161,334	11,637	13,123	366,943	24,760	378,576	181,428	4089,744
22,600	376423	22,594	-1,600	334,350	60,000	29439,778	17716,942	0,810	169,903	161,286	11,742	13,011	364,390	24,752	376,127	181,599	4101,211

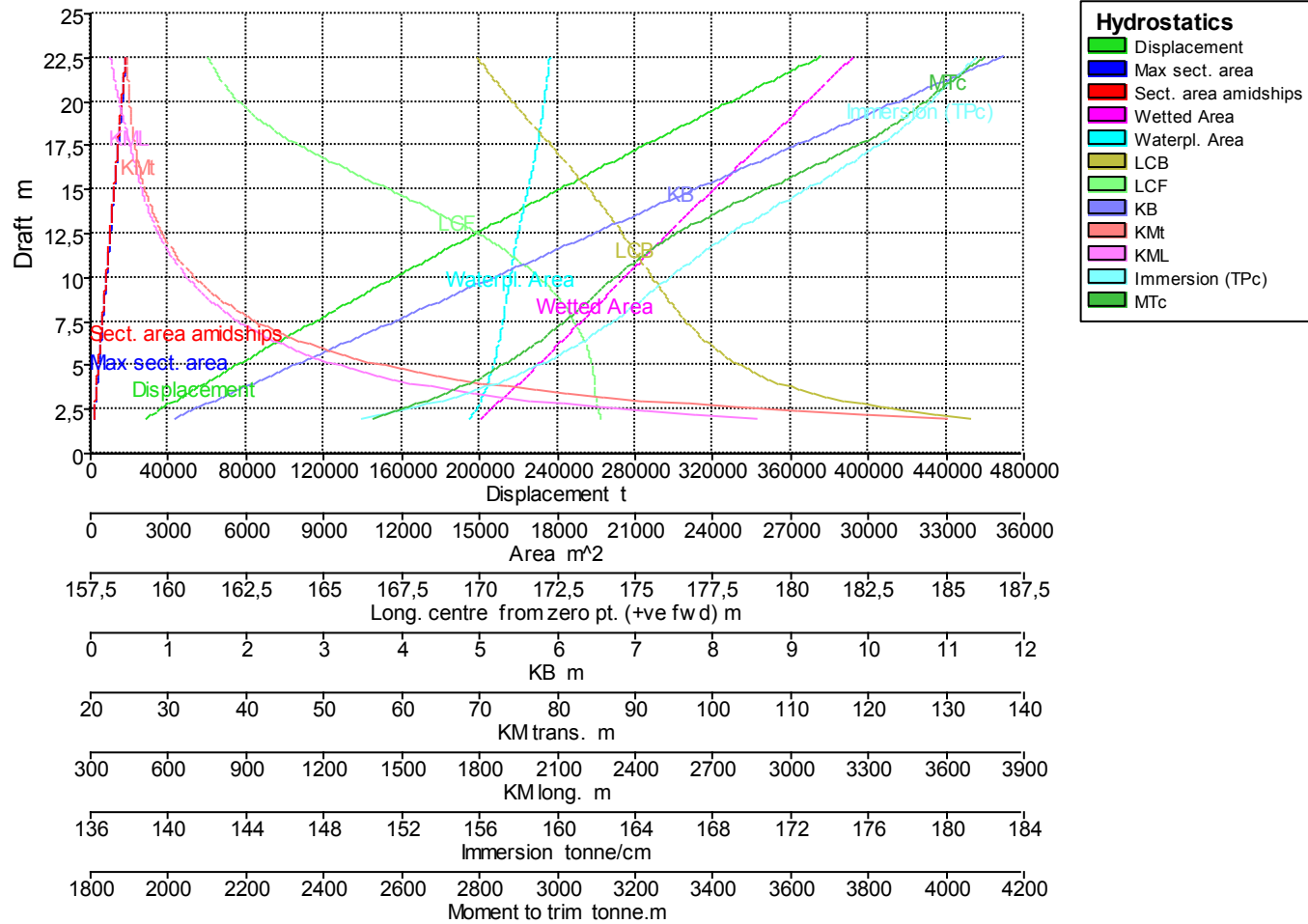

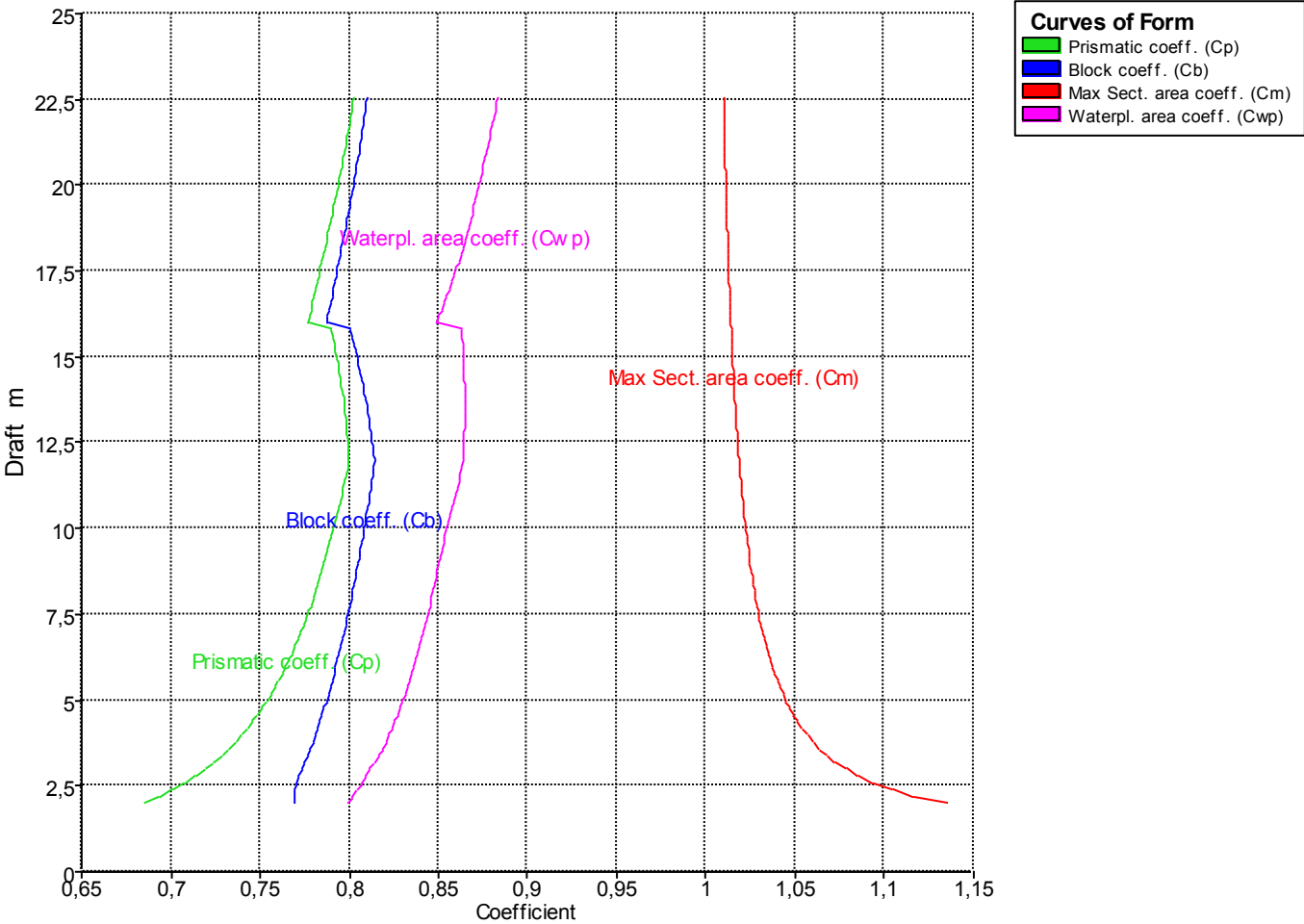

- **Para un trimado de -3,2 m:**

Draft Amidships m	Displacement t	Draft at LCF m	Trim (+ve by stern) m	WL Length m	Beam max extents on WL m	Wetted Area m ²	Waterpl. Area m ²	Block coeff. (Cb)	LCB from zero pt. (+ve fwd) m	LCF from zero pt. (+ve fwd) m	KB m	BMt m	BML m	KMt m	KML m	Immersion (TPc) tonne/cm	MTC tonne.m
2,000	29746	2,131	-3,200	307,907	59,900	15037,709	14615,457	0,790	199,162	175,831	1,227	125,069	2775,708	126,290	2776,801	149,808	2521,135
2,200	32753	2,329	-3,200	308,250	59,972	15207,472	14717,904	0,789	197,009	175,618	1,319	115,153	2557,162	116,467	2558,358	150,859	2555,863
2,400	35780	2,528	-3,200	308,586	59,992	15371,161	14810,136	0,787	195,191	175,456	1,413	106,692	2371,447	108,100	2372,745	151,804	2587,737
2,600	38824	2,726	-3,200	308,923	60,000	15529,023	14892,096	0,787	193,638	175,332	1,508	99,363	2211,233	100,867	2212,634	152,644	2616,687
2,800	41885	2,925	-3,200	309,260	60,000	15685,118	14968,433	0,787	192,295	175,212	1,605	92,983	2072,593	94,584	2074,098	153,426	2644,453
3,000	44961	3,124	-3,200	309,596	60,000	15838,738	15038,473	0,787	191,122	175,100	1,702	87,365	1950,998	89,063	1952,606	154,144	2670,584
3,200	48051	3,323	-3,200	309,933	60,000	15987,871	15100,195	0,788	190,088	175,023	1,800	82,349	1842,681	84,145	1844,392	154,777	2694,127
3,400	51153	3,523	-3,200	310,265	60,000	16130,829	15158,300	0,788	189,173	174,944	1,898	77,883	1746,398	79,777	1748,211	155,373	2716,659
3,600	54266	3,722	-3,200	310,560	60,000	16277,284	15213,361	0,789	188,355	174,868	1,997	73,881	1660,215	75,874	1662,132	155,937	2738,282
3,800	57391	3,921	-3,200	310,854	60,000	16421,922	15264,721	0,790	187,620	174,794	2,097	70,265	1582,398	72,358	1584,418	156,463	2758,714
4,000	60525	4,120	-3,200	311,075	60,000	16562,620	15311,169	0,791	186,955	174,738	2,196	66,974	1511,340	69,167	1513,463	156,939	2777,253
4,200	63669	4,320	-3,200	311,283	60,000	16702,562	15355,649	0,792	186,352	174,682	2,296	63,983	1446,701	66,277	1448,927	157,395	2795,092
4,400	66822	4,519	-3,200	311,491	60,000	16842,013	15398,717	0,793	185,802	174,628	2,397	61,254	1387,769	63,647	1390,099	157,837	2812,562
4,600	69984	4,719	-3,200	311,699	60,000	16980,649	15439,758	0,794	185,298	174,571	2,497	58,749	1333,633	61,243	1336,066	158,258	2829,297
4,800	73154	4,918	-3,200	311,906	60,000	17118,640	15479,158	0,795	184,834	174,516	2,598	56,442	1283,779	59,037	1286,315	158,661	2845,483
5,000	76332	5,118	-3,200	312,114	60,000	17255,745	15516,357	0,795	184,406	174,462	2,699	54,307	1237,575	57,003	1240,214	159,043	2860,835
5,200	79518	5,317	-3,200	312,322	60,000	17392,193	15551,979	0,796	184,009	174,411	2,800	52,329	1194,712	55,126	1197,453	159,408	2875,620
5,400	82710	5,517	-3,200	312,530	60,000	17527,934	15585,192	0,797	183,638	174,347	2,901	50,493	1154,558	53,392	1157,403	159,748	2889,123
5,600	85908	5,716	-3,200	312,738	60,000	17663,112	15617,558	0,798	183,291	174,286	3,002	48,783	1117,239	51,783	1120,187	160,080	2902,468
5,800	89113	5,915	-3,200	312,876	60,000	17797,556	15648,144	0,798	182,966	174,220	3,103	47,184	1082,231	50,285	1085,281	160,393	2915,034
6,000	92323	6,115	-3,200	313,014	60,000	17931,691	15677,694	0,799	182,661	174,155	3,204	45,686	1049,465	48,888	1052,618	160,696	2927,283
6,200	95540	6,314	-3,200	313,152	60,000	18065,389	15706,096	0,800	182,373	174,091	3,306	44,280	1018,692	47,583	1021,948	160,987	2939,119
6,400	98763	6,514	-3,200	313,289	60,000	18198,666	15733,450	0,801	182,102	174,029	3,407	42,957	989,742	46,362	993,101	161,268	2950,595
6,600	101991	6,713	-3,200	313,427	60,000	18331,536	15759,832	0,802	181,845	173,967	3,509	41,710	962,444	45,217	965,906	161,538	2961,692
6,800	105224	6,912	-3,200	313,565	60,000	18464,078	15785,260	0,802	181,602	173,903	3,610	40,535	936,639	44,143	940,204	161,799	2972,373
7,000	108463	7,112	-3,200	313,703	60,000	18596,510	15810,172	0,803	181,371	173,836	3,712	39,426	912,255	43,136	915,922	162,054	2982,825
7,200	111706	7,311	-3,200	313,841	60,000	18728,819	15834,455	0,804	181,152	173,764	3,813	38,379	889,161	42,190	892,932	162,303	2993,008
7,400	114955	7,510	-3,200	313,939	60,000	18860,964	15858,031	0,805	180,942	173,681	3,915	37,387	867,228	41,301	871,101	162,545	3002,835
7,600	118208	7,709	-3,200	314,021	60,000	18993,178	15881,286	0,805	180,741	173,597	4,017	36,447	846,445	40,463	850,420	162,783	3012,603
7,800	121466	7,908	-3,200	314,103	60,000	19125,388	15904,009	0,806	180,548	173,513	4,119	35,554	826,697	39,671	830,776	163,016	3022,220
8,000	124729	8,108	-3,200	314,184	60,000	19256,410	15925,978	0,807	180,363	173,426	4,220	34,702	807,875	38,921	812,056	163,241	3031,561
8,200	127996	8,307	-3,200	314,266	60,000	19388,530	15947,867	0,808	180,185	173,338	4,322	33,890	790,031	38,210	794,315	163,466	3041,096
8,400	131267	8,506	-3,200	314,348	60,000	19520,451	15969,065	0,808	180,013	173,251	4,424	33,114	772,987	37,536	777,373	163,683	3050,401
8,600	134543	8,705	-3,200	314,430	60,000	19652,264	15989,727	0,809	179,847	173,164	4,526	32,371	756,706	36,896	761,195	163,895	3059,553
8,800	137823	8,904	-3,200	314,528	60,000	19783,874	16009,791	0,810	179,687	173,078	4,628	31,662	741,109	36,288	745,701	164,100	3068,436

PETROLERO VLCC DE 300.000 TPM

CUADERNO IV: COMPARTIMENTADO Y CÁLCULOS DE ARQUITECTURA NAVAL

PEDRO LEMOS GONZÁLEZ

Draft Amidships m	Displacement t	Draft at LCF m	Trim (+ve by stern) m	WL Length m	Beam max extents on WL m	Wetted Area m ²	Waterpl. Area m ²	Block coeff. (Cb)	LCB from zero pt. (+ve fwd) m	LCF from zero pt. (+ve fwd) m	KB m	BMt m	BML m	KMt m	KML m	Immersion (TPc) tonne/cm	MTc tonne.m
9,000	141107	9,103	-3,200	314,656	60,000	19915,585	16029,726	0,810	179,532	172,986	4,730	30,983	726,215	35,711	730,909	164,305	3077,328
9,200	144395	9,302	-3,200	314,759	60,000	20047,399	16049,498	0,811	179,382	172,884	4,831	30,335	711,960	35,165	716,756	164,507	3086,161
9,400	147687	9,501	-3,200	314,860	60,000	20179,334	16069,414	0,811	179,236	172,778	4,933	29,715	698,348	34,647	703,247	164,711	3095,138
9,600	150983	9,700	-3,200	314,961	60,000	20311,419	16089,411	0,812	179,093	172,671	5,035	29,122	685,321	34,156	690,323	164,916	3104,181
9,800	154283	9,899	-3,200	315,062	60,000	20443,864	16109,870	0,812	178,955	172,559	5,137	28,554	672,900	33,690	678,004	165,126	3113,562
10,000	157588	10,098	-3,200	315,163	60,000	20576,697	16130,848	0,813	178,819	172,440	5,239	28,009	661,058	33,247	666,265	165,341	3123,334
10,200	160897	10,297	-3,200	315,264	60,000	20709,685	16151,949	0,814	178,687	172,319	5,341	27,487	649,704	32,827	655,014	165,557	3133,218
10,400	164210	10,495	-3,200	315,365	60,000	20842,929	16173,277	0,814	178,557	172,196	5,443	26,985	638,818	32,427	644,230	165,776	3143,258
10,600	167528	10,694	-3,200	315,466	60,000	20976,587	16195,063	0,815	178,429	172,065	5,545	26,503	628,411	32,047	633,926	165,999	3153,655
10,800	170850	10,893	-3,200	315,568	60,000	21110,657	16217,300	0,815	178,304	171,930	5,647	26,040	618,448	31,686	624,065	166,227	3164,362
11,000	174177	11,091	-3,200	315,669	60,000	21244,941	16239,869	0,816	178,181	171,789	5,749	25,594	608,905	31,342	614,625	166,459	3175,390
11,200	177509	11,290	-3,200	315,767	60,000	21379,147	16261,840	0,816	178,060	171,646	5,852	25,160	599,691	31,010	605,514	166,684	3186,367
11,400	180845	11,489	-3,200	315,859	60,000	21513,929	16283,910	0,817	177,940	171,496	5,954	24,740	590,856	30,692	596,781	166,910	3197,660
11,600	184185	11,687	-3,200	315,950	60,000	21648,935	16306,163	0,817	177,821	171,345	6,056	24,334	582,349	30,389	588,377	167,138	3209,101
11,800	187530	11,886	-3,200	316,042	60,000	21784,028	16328,437	0,818	177,704	171,193	6,158	23,943	574,131	30,100	580,261	167,366	3220,559
12,000	190880	12,084	-3,200	316,134	60,000	21919,480	16351,105	0,818	177,588	171,037	6,261	23,566	566,230	29,826	572,463	167,599	3232,290
12,200	194235	12,282	-3,200	316,226	60,000	22055,131	16374,342	0,819	177,474	170,876	6,363	23,202	558,655	29,564	564,991	167,837	3244,441
12,400	197594	12,481	-3,200	316,318	60,000	22191,762	16399,055	0,819	177,360	170,702	6,465	22,851	551,509	29,315	557,947	168,090	3257,736
12,600	200958	12,679	-3,200	316,410	60,000	22328,792	16424,119	0,820	177,246	170,523	6,568	22,511	544,624	29,078	551,165	168,347	3271,278
12,800	204328	12,877	-3,200	316,615	60,000	22466,083	16449,418	0,820	177,134	170,343	6,670	22,183	537,975	28,852	544,619	168,607	3284,978
13,000	207703	13,075	-3,200	317,133	60,000	22576,839	16474,868	0,819	177,022	170,162	6,773	21,865	531,544	28,636	538,290	168,867	3298,795
13,200	211083	13,273	-3,200	317,652	60,000	22714,693	16501,934	0,819	176,911	169,964	6,875	21,557	525,500	28,432	532,349	169,145	3313,896
13,400	214469	13,471	-3,200	318,170	60,000	22854,003	16530,605	0,818	176,799	169,751	6,978	21,260	519,824	28,237	526,777	169,439	3330,279
13,600	217860	13,669	-3,200	318,689	60,000	22993,946	16559,814	0,817	176,688	169,532	7,080	20,971	514,373	28,051	521,429	169,738	3347,101
13,800	221258	13,867	-3,200	319,207	60,000	23134,184	16589,371	0,817	176,576	169,307	7,183	20,691	509,134	27,873	516,293	170,041	3364,345
14,000	224662	14,065	-3,200	319,725	60,000	23274,457	16618,548	0,816	176,464	169,082	7,286	20,416	504,041	27,701	511,302	170,340	3381,612
14,200	228072	14,263	-3,200	320,242	60,000	23414,820	16647,462	0,816	176,352	168,860	7,389	20,148	499,080	27,536	506,444	170,636	3398,854
14,400	231487	14,460	-3,200	320,780	60,000	23556,761	16675,842	0,815	176,240	168,642	7,492	19,887	494,198	27,378	501,666	170,927	3415,723
14,600	234909	14,658	-3,200	321,422	60,000	23699,399	16706,245	0,814	176,127	168,405	7,595	19,634	489,686	27,228	497,257	171,239	3434,347
14,800	238337	14,856	-3,200	322,065	60,000	23842,072	16736,541	0,813	176,014	168,169	7,698	19,388	485,281	27,084	492,955	171,550	3452,921
15,000	241771	15,053	-3,200	322,708	60,000	23985,034	16767,027	0,812	175,901	167,932	7,801	19,148	481,008	26,948	488,786	171,862	3471,662
15,200	245211	15,251	-3,200	323,351	60,000	24127,955	16797,315	0,811	175,788	167,696	7,904	18,916	476,825	26,819	484,706	172,172	3490,288
15,400	248657	15,449	-3,200	323,993	60,000	24269,119	16825,358	0,810	175,674	167,483	8,007	18,690	472,490	26,696	480,474	172,460	3506,973
15,600	252110	15,647	-3,200	324,636	60,000	24414,382	16857,630	0,809	175,560	167,229	8,111	18,470	468,732	26,580	476,820	172,791	3527,325
15,800	255568	15,844	-3,200	325,279	60,000	24557,823	16887,910	0,809	175,446	166,994	8,214	18,255	464,863	26,468	473,054	173,101	3546,109
16,000	259033	16,042	-3,200	325,922	60,000	24701,918	16917,711	0,808	175,331	166,759	8,317	18,042	461,116	26,358	469,411	173,407	3565,160
16,200	262504	16,240	-3,200	326,564	60,000	24846,749	16947,598	0,807	175,216	166,522	8,421	17,832	457,510	26,252	465,909	173,713	3584,649
16,400	265981	16,438	-3,200	327,207	60,000	24989,164	16974,731	0,806	175,101	166,309	8,524	17,627	453,720	26,150	462,223	173,991	3601,971

PETROLERO VLCC DE 300.000 TPM

CUADERNO IV: COMPARTIMENTADO Y CÁLCULOS DE ARQUITECTURA NAVAL

PEDRO LEMOS GONZÁLEZ

Draft Amidships m	Displacement t	Draft at LCF m	Trim (+ve by stern) m	WL Length m	Beam max extents on WL m	Wetted Area m ²	Waterpl. Area m ²	Block coeff. (Cb)	LCB from zero pt. (+ve fwd) m	LCF from zero pt. (+ve fwd) m	KB m	BMt m	BML m	KMt m	KML m	Immersion (TPc) tonne/cm	MTc tonne.m
16,600	269464	16,635	-3,200	327,850	60,000	25133,959	17003,805	0,805	174,986	166,076	8,628	17,426	450,247	26,053	458,853	174,289	3621,205
16,800	272953	16,833	-3,200	333,966	60,000	25279,080	17032,952	0,791	174,870	165,842	8,732	17,229	446,878	25,960	455,588	174,588	3640,669
17,000	276447	17,031	-3,200	333,966	60,000	25424,223	17061,943	0,792	174,755	165,609	8,835	17,038	443,577	25,872	452,391	174,885	3660,095
17,200	279948	17,228	-3,200	333,966	60,000	25568,882	17090,218	0,792	174,639	165,383	8,939	16,850	440,282	25,788	449,200	175,175	3678,962
17,400	283454	17,426	-3,200	333,966	60,000	25713,527	17118,232	0,793	174,523	165,160	9,043	16,667	437,044	25,709	446,066	175,462	3697,716
17,600	286965	17,624	-3,200	333,966	60,000	25854,681	17142,502	0,794	174,408	164,975	9,147	16,489	433,495	25,635	442,620	175,711	3713,106
17,800	290482	17,822	-3,200	333,966	60,000	26002,503	17173,415	0,795	174,292	164,724	9,251	16,315	430,699	25,564	439,928	176,028	3734,562
18,000	294006	18,020	-3,200	333,966	60,000	26148,615	17202,372	0,795	174,176	164,493	9,354	16,144	427,772	25,498	437,106	176,324	3754,338
18,200	297535	18,217	-3,200	333,966	60,000	26294,434	17230,424	0,796	174,060	164,271	9,458	15,977	424,846	25,434	434,284	176,612	3773,577
18,400	301070	18,416	-3,200	333,966	60,000	26432,956	17250,458	0,797	173,944	164,127	9,562	15,812	421,212	25,374	430,754	176,817	3785,713
18,600	304609	18,614	-3,200	333,966	60,000	26580,836	17279,723	0,797	173,828	163,894	9,666	15,650	418,584	25,316	428,230	177,117	3806,575
18,800	308154	18,812	-3,200	333,966	60,000	26726,284	17305,762	0,798	173,713	163,697	9,771	15,491	415,712	25,261	425,463	177,384	3824,644
19,000	311704	19,010	-3,200	333,966	60,000	26869,922	17329,244	0,799	173,598	163,524	9,875	15,335	412,671	25,209	422,525	177,625	3840,539
19,200	315258	19,209	-3,200	333,966	60,000	27012,508	17351,144	0,799	173,483	163,369	9,979	15,181	409,555	25,159	419,514	177,849	3855,139
19,400	318817	19,407	-3,200	333,970	60,000	27154,663	17372,357	0,800	173,370	163,222	10,083	15,031	406,450	25,113	416,514	178,067	3869,234
19,600	322381	19,606	-3,200	333,983	60,000	27293,855	17393,341	0,801	173,257	163,086	10,187	14,883	403,390	25,070	413,557	178,282	3883,165
19,800	325948	19,805	-3,200	333,997	60,000	27435,600	17414,766	0,801	173,145	162,964	10,291	14,739	400,425	25,030	410,697	178,501	3897,459
20,000	329520	20,003	-3,200	334,010	60,000	27577,288	17436,192	0,802	173,034	162,851	10,396	14,598	397,524	24,993	407,900	178,721	3911,827
20,200	333097	20,202	-3,200	334,024	60,000	27718,786	17457,254	0,803	172,924	162,742	10,500	14,459	394,652	24,959	405,133	178,937	3925,929
20,400	336677	20,401	-3,200	334,037	60,000	27860,083	17477,990	0,803	172,815	162,638	10,604	14,324	391,813	24,927	402,398	179,149	3939,808
20,600	340262	20,600	-3,200	334,051	60,000	28001,190	17498,530	0,804	172,707	162,543	10,708	14,191	389,017	24,898	399,707	179,360	3953,593
20,800	343851	20,800	-3,200	334,083	60,000	28142,234	17519,011	0,805	172,601	162,453	10,813	14,060	386,270	24,872	397,064	179,570	3967,350
21,000	347445	20,999	-3,200	334,139	60,000	28283,142	17539,269	0,805	172,495	162,367	10,917	13,933	383,558	24,849	394,457	179,778	3980,941
21,200	351042	21,198	-3,200	334,195	60,000	28423,897	17559,254	0,806	172,391	162,287	11,021	13,808	380,878	24,828	391,881	179,982	3994,347
21,400	354644	21,397	-3,200	334,250	60,000	28564,826	17579,426	0,806	172,288	162,211	11,126	13,685	378,261	24,810	389,369	180,189	4007,922
21,600	358249	21,596	-3,200	334,306	60,000	28705,521	17599,131	0,807	172,186	162,138	11,230	13,565	375,660	24,794	386,872	180,391	4021,157
21,800	361859	21,796	-3,200	334,362	60,000	28846,225	17618,713	0,807	172,086	162,067	11,335	13,447	373,097	24,781	384,414	180,592	4034,314
22,000	365473	21,995	-3,200	334,418	60,000	28986,807	17637,920	0,808	171,986	161,999	11,439	13,331	370,557	24,769	381,978	180,789	4047,227
22,200	369090	22,194	-3,200	334,474	60,000	29127,443	17657,110	0,808	171,888	161,932	11,544	13,217	368,062	24,760	379,587	180,985	4060,144
22,400	372712	22,394	-3,200	334,530	60,000	29268,242	17676,319	0,809	171,791	161,870	11,648	13,106	365,619	24,753	377,249	181,182	4073,174
22,600	376337	22,593	-3,200	334,586	60,000	29408,943	17695,042	0,809	171,695	161,813	11,753	12,995	363,194	24,747	374,929	181,374	4085,944

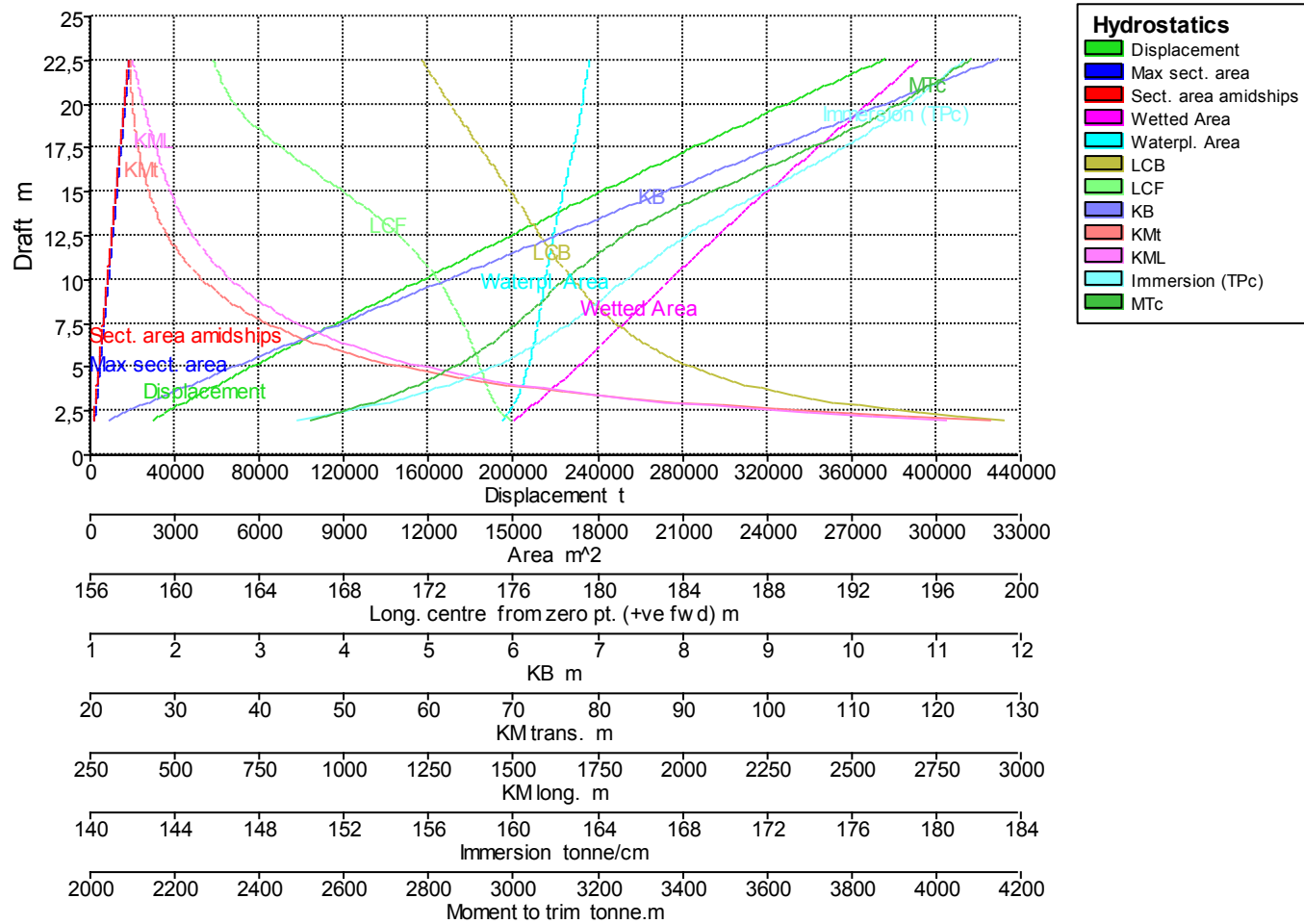

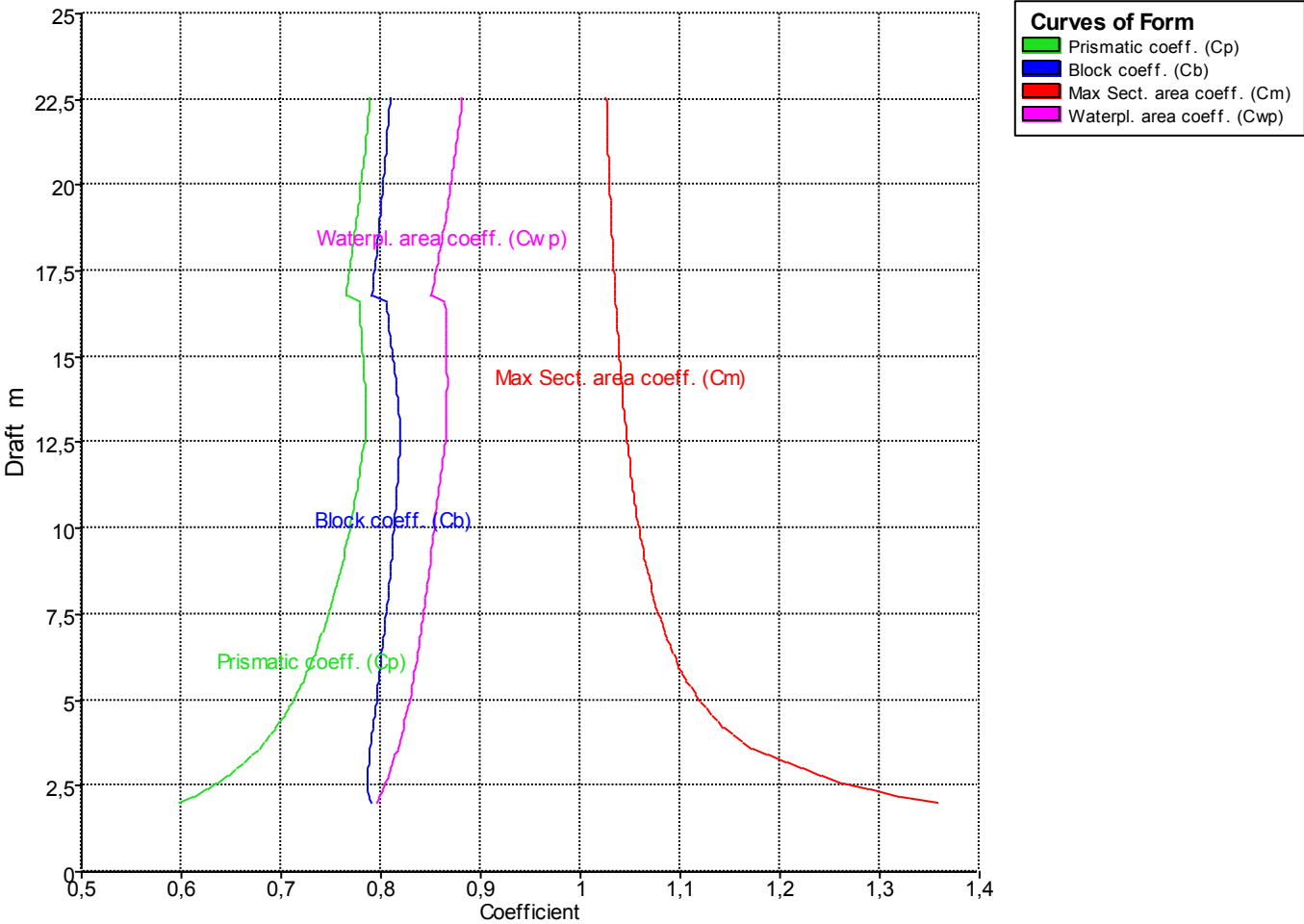

• **Para un trimado de -4.8 m:**

Draft Amidships m	Displacement t	Draft at LCF m	Trim (+ve by stern) m	WL Length m	Beam max extents on WL m	Wetted Area m ²	Waterpl. Area m ²	Block coeff. (Cb)	LCB from zero pt. (+ve fwd) m	LCF from zero pt. (+ve fwd) m	KB m	BMt m	BML m	KMt m	KML m	Immersion (TPc) tonne/cm	MTC tonne.m
2,000	30817	2,245	-4,800	293,948	59,982	14891,104	14435,886	0,858	211,414	179,098	1,421	120,248	2556,507	121,656	2557,649	147,968	2403,947
2,200	33798	2,427	-4,800	307,743	59,996	15150,195	14631,885	0,815	208,501	177,854	1,501	111,203	2430,012	112,693	2431,248	149,977	2505,068
2,400	36812	2,618	-4,800	309,314	60,000	15344,462	14757,390	0,808	205,966	177,279	1,585	103,360	2282,011	104,933	2283,347	151,263	2560,904
2,600	39847	2,814	-4,800	309,632	60,000	15512,606	14850,933	0,806	203,769	176,961	1,671	96,504	2139,694	98,165	2141,132	152,222	2597,701
2,800	42900	3,010	-4,800	309,950	60,000	15675,254	14935,138	0,804	201,852	176,701	1,760	90,505	2013,499	92,255	2015,039	153,085	2630,337
3,000	45970	3,207	-4,800	310,281	60,000	15830,014	15007,320	0,803	200,166	176,502	1,850	85,175	1899,933	87,016	1901,576	153,825	2658,072
3,200	49053	3,404	-4,800	310,551	60,000	15982,024	15074,062	0,803	198,673	176,316	1,941	80,438	1798,850	82,370	1800,595	154,509	2683,993
3,400	52151	3,602	-4,800	310,801	60,000	16132,657	15136,828	0,802	197,341	176,144	2,034	76,204	1708,464	78,230	1710,312	155,152	2708,604
3,600	55260	3,799	-4,800	311,052	60,000	16279,358	15193,178	0,802	196,146	176,005	2,128	72,373	1626,507	74,493	1628,458	155,730	2730,947
3,800	58381	3,998	-4,800	311,302	60,000	16423,773	15245,128	0,802	195,067	175,884	2,223	68,903	1552,051	71,118	1554,105	156,263	2751,626
4,000	61513	4,196	-4,800	311,552	60,000	16563,230	15294,941	0,803	194,089	175,765	2,318	65,755	1484,559	68,066	1486,715	156,773	2771,693
4,200	64654	4,394	-4,800	311,786	60,000	16705,963	15341,800	0,803	193,199	175,652	2,414	62,882	1422,826	65,289	1425,085	157,253	2790,641
4,400	67805	4,593	-4,800	311,995	60,000	16846,828	15385,287	0,803	192,384	175,554	2,511	60,240	1366,057	62,744	1368,418	157,699	2808,422
4,600	70963	4,791	-4,800	312,203	60,000	16985,853	15424,464	0,803	191,633	175,449	2,608	57,811	1313,195	60,413	1315,660	158,101	2824,039
4,800	74128	4,990	-4,800	312,412	60,000	17123,495	15462,607	0,804	190,940	175,354	2,706	55,573	1264,612	58,273	1267,179	158,492	2839,452
5,000	77301	5,188	-4,800	312,551	60,000	17260,201	15498,672	0,804	190,298	175,256	2,803	53,504	1219,497	56,301	1222,167	158,861	2853,950
5,200	80482	5,387	-4,800	312,688	60,000	17396,443	15533,483	0,805	189,702	175,160	2,902	51,585	1177,662	54,481	1180,435	159,218	2868,040
5,400	83669	5,586	-4,800	312,826	60,000	17532,068	15566,753	0,805	189,146	175,067	3,000	49,799	1138,679	52,793	1141,555	159,559	2881,542
5,600	86864	5,784	-4,800	312,963	60,000	17667,058	15598,555	0,806	188,627	174,979	3,099	48,132	1102,260	51,226	1105,239	159,885	2894,495
5,800	90064	5,983	-4,800	313,100	60,000	17801,574	15629,017	0,806	188,140	174,893	3,198	46,574	1068,159	49,767	1071,240	160,197	2906,938
6,000	93271	6,182	-4,800	313,237	60,000	17935,791	15658,380	0,807	187,683	174,807	3,297	45,114	1036,178	48,406	1039,362	160,498	2918,961
6,200	96483	6,381	-4,800	313,375	60,000	18069,656	15686,539	0,807	187,253	174,722	3,397	43,742	1006,107	47,134	1009,393	160,787	2930,543
6,400	99702	6,579	-4,800	313,513	60,000	18203,122	15713,555	0,808	186,847	174,635	3,496	42,452	977,757	45,943	981,147	161,064	2941,649
6,600	102925	6,778	-4,800	313,612	60,000	18335,965	15738,956	0,809	186,464	174,544	3,596	41,235	950,882	44,826	954,374	161,324	2951,984
6,800	106154	6,977	-4,800	313,693	60,000	18468,434	15763,419	0,809	186,100	174,455	3,696	40,085	925,476	43,776	929,070	161,575	2961,948
7,000	109388	7,175	-4,800	313,775	60,000	18600,595	15787,054	0,810	185,754	174,368	3,796	38,998	901,438	42,789	905,135	161,817	2971,625
7,200	112627	7,374	-4,800	313,857	60,000	18731,342	15809,789	0,810	185,426	174,279	3,896	37,969	878,609	41,860	882,409	162,050	2980,855
7,400	115870	7,573	-4,800	313,939	60,000	18862,980	15832,230	0,811	185,113	174,192	3,996	36,994	857,009	40,986	860,912	162,280	2990,051
7,600	119117	7,771	-4,800	314,021	60,000	18994,601	15854,337	0,812	184,814	174,104	4,096	36,070	836,516	40,162	840,521	162,507	2999,130
7,800	122369	7,970	-4,800	314,103	60,000	19126,234	15876,123	0,812	184,528	174,016	4,197	35,193	817,049	39,385	821,156	162,730	3008,105
8,000	125626	8,169	-4,800	314,185	60,000	19257,992	15897,794	0,813	184,254	173,922	4,297	34,358	798,576	38,651	802,785	162,952	3017,156
8,200	128887	8,367	-4,800	314,266	60,000	19389,779	15919,009	0,813	183,991	173,827	4,397	33,563	780,970	37,957	785,282	163,170	3026,068
8,400	132152	8,566	-4,800	314,324	60,000	19521,410	15939,139	0,814	183,739	173,727	4,498	32,803	764,073	37,298	768,487	163,376	3034,445
8,600	135421	8,764	-4,800	314,379	60,000	19652,977	15958,786	0,814	183,496	173,628	4,599	32,077	747,930	36,672	752,447	163,578	3042,685
8,800	138694	8,963	-4,800	314,434	60,000	19784,559	15978,286	0,815	183,262	173,528	4,699	31,382	732,546	36,078	737,165	163,777	3051,021

PETROLERO VLCC DE 300.000 TPM

CUADERNO IV: COMPARTIMENTADO Y CÁLCULOS DE ARQUITECTURA NAVAL

PEDRO LEMOS GONZÁLEZ

Draft Amidships m	Displacement t	Draft at LCF m	Trim (+ve by stern) m	WL Length m	Beam max extents on WL m	Wetted Area m ²	Waterpl. Area m ²	Block coeff. (Cb)	LCB from zero pt. (+ve fwd) m	LCF from zero pt. (+ve fwd) m	KB m	BMt m	BML m	KMt m	KML m	Immersion (TPc) tonne/cm	MTc tonne.m
9,000	141972	9,161	-4,800	314,489	60,000	19916,007	15997,374	0,816	183,036	173,429	4,800	30,715	717,825	35,512	722,547	163,973	3059,265
9,200	145253	9,360	-4,800	314,544	60,000	20047,432	16016,254	0,816	182,818	173,330	4,901	30,077	703,745	34,975	708,569	164,167	3067,504
9,400	148538	9,559	-4,800	314,599	60,000	20178,747	16034,801	0,817	182,607	173,232	5,002	29,465	690,235	34,464	695,162	164,357	3075,608
9,600	151826	9,757	-4,800	314,682	60,000	20310,125	16053,285	0,817	182,402	173,133	5,103	28,879	677,294	33,978	682,322	164,546	3083,732
9,800	155119	9,955	-4,800	314,783	60,000	20441,803	16072,255	0,818	182,204	173,028	5,203	28,317	664,956	33,517	670,087	164,741	3092,216
10,000	158416	10,154	-4,800	314,884	60,000	20573,630	16091,481	0,818	182,012	172,919	5,304	27,778	653,158	33,080	658,391	164,938	3100,930
10,200	161716	10,352	-4,800	314,985	60,000	20705,611	16110,814	0,818	181,825	172,807	5,405	27,261	641,839	32,664	647,174	165,136	3109,729
10,400	165021	10,550	-4,800	315,082	60,000	20837,821	16130,217	0,819	181,644	172,690	5,507	26,764	630,968	32,268	636,406	165,335	3118,603
10,600	168329	10,749	-4,800	315,174	60,000	20970,372	16149,848	0,819	181,466	172,566	5,608	26,287	620,536	31,892	626,076	165,536	3127,633
10,800	171642	10,947	-4,800	315,266	60,000	21103,227	16169,936	0,820	181,293	172,436	5,709	25,828	610,554	31,534	616,196	165,742	3137,011
11,000	174958	11,145	-4,800	315,357	60,000	21236,290	16190,244	0,820	181,124	172,305	5,810	25,387	600,959	31,194	606,703	165,950	3146,531
11,200	178279	11,343	-4,800	315,449	60,000	21369,641	16210,885	0,820	180,958	172,171	5,911	24,962	591,746	30,870	597,593	166,162	3156,292
11,400	181604	11,541	-4,800	315,541	60,000	21503,498	16232,102	0,821	180,796	172,031	6,013	24,552	582,935	30,562	588,884	166,379	3166,506
11,600	184934	11,739	-4,800	315,633	60,000	21637,463	16253,001	0,821	180,637	171,892	6,114	24,154	574,422	30,266	580,473	166,593	3176,707
11,800	188268	11,937	-4,800	315,724	60,000	21771,424	16273,989	0,822	180,480	171,750	6,215	23,768	566,255	29,981	572,409	166,808	3187,265
12,000	191606	12,134	-4,800	315,816	60,000	21905,603	16295,228	0,822	180,327	171,605	6,317	23,395	558,402	29,709	564,658	167,026	3198,092
12,200	194949	12,332	-4,800	315,908	60,000	22040,536	16317,266	0,822	180,176	171,452	6,418	23,034	550,901	29,450	557,260	167,252	3209,514
12,400	198296	12,530	-4,800	315,999	60,000	22175,557	16339,343	0,823	180,027	171,299	6,520	22,685	543,642	29,203	550,102	167,478	3220,959
12,600	201647	12,728	-4,800	316,091	60,000	22310,780	16361,589	0,823	179,881	171,144	6,621	22,348	536,627	28,967	543,189	167,706	3232,520
12,800	205004	12,925	-4,800	316,183	60,000	22446,335	16384,150	0,824	179,736	170,985	6,723	22,022	529,861	28,743	536,526	167,938	3244,299
13,000	208365	13,123	-4,800	316,274	60,000	22582,229	16407,635	0,824	179,593	170,815	6,825	21,707	523,411	28,529	530,179	168,178	3256,806
13,200	211731	13,320	-4,800	316,365	60,000	22718,929	16432,014	0,824	179,452	170,636	6,926	21,402	517,257	28,326	524,127	168,428	3270,000
13,400	215102	13,517	-4,800	316,455	60,000	22856,133	16456,865	0,825	179,312	170,453	7,028	21,106	511,329	28,132	518,302	168,683	3283,519
13,600	218478	13,715	-4,800	316,545	60,000	22993,386	16481,753	0,825	179,174	170,270	7,130	20,820	505,573	27,948	512,647	168,938	3297,056
13,800	221859	13,912	-4,800	317,256	60,000	23104,057	16507,014	0,824	179,036	170,084	7,232	20,543	500,019	27,772	507,196	169,197	3310,877
14,000	225246	14,109	-4,800	317,767	60,000	23242,463	16534,451	0,823	178,900	169,877	7,334	20,274	494,866	27,606	502,145	169,478	3326,418
14,200	228638	14,306	-4,800	318,278	60,000	23381,869	16562,910	0,823	178,765	169,661	7,436	20,013	489,966	27,447	497,348	169,770	3342,773
14,400	232036	14,503	-4,800	318,789	60,000	23521,551	16591,297	0,822	178,630	169,444	7,538	19,758	485,225	27,294	492,709	170,061	3359,348
14,600	235440	14,699	-4,800	319,300	60,000	23661,457	16619,771	0,821	178,495	169,224	7,640	19,508	480,656	27,146	488,243	170,353	3376,287
14,800	238850	14,896	-4,800	319,810	60,000	23801,525	16648,239	0,821	178,361	169,004	7,742	19,264	476,218	27,004	483,908	170,644	3393,337
15,000	242265	15,093	-4,800	320,321	60,000	23941,762	16675,321	0,820	178,227	168,798	7,845	19,027	471,740	26,869	479,533	170,922	3409,261
15,200	245687	15,290	-4,800	320,865	60,000	24083,875	16705,167	0,819	178,095	168,564	7,947	18,797	467,682	26,741	475,578	171,228	3427,518
15,400	249114	15,486	-4,800	321,498	60,000	24226,359	16735,282	0,818	177,962	168,329	8,049	18,572	463,756	26,620	471,755	171,537	3446,039
15,600	252547	15,683	-4,800	322,130	60,000	24369,023	16765,440	0,817	177,829	168,093	8,152	18,354	459,931	26,504	468,032	171,846	3464,619
15,800	255987	15,879	-4,800	322,763	60,000	24511,725	16795,446	0,816	177,697	167,857	8,254	18,142	456,182	26,394	464,386	172,153	3483,101
16,000	259433	16,076	-4,800	323,396	60,000	24654,623	16825,544	0,815	177,564	167,621	8,357	17,935	452,531	26,290	460,838	172,462	3501,682
16,200	262885	16,272	-4,800	324,029	60,000	24795,704	16853,409	0,814	177,432	167,407	8,460	17,734	448,727	26,191	457,138	172,747	3518,353
16,400	266343	16,469	-4,800	324,662	60,000	24940,615	16884,498	0,813	177,300	167,160	8,562	17,535	445,401	26,095	453,915	173,066	3538,231

PETROLERO VLCC DE 300.000 TPM

CUADERNO IV: COMPARTIMENTADO Y CÁLCULOS DE ARQUITECTURA NAVAL

PEDRO LEMOS GONZÁLEZ

Draft Amidships m	Displacement t	Draft at LCF m	Trim (+ve by stern) m	WL Length m	Beam max extents on WL m	Wetted Area m ²	Waterpl. Area m ²	Block coeff. (Cb)	LCB from zero pt. (+ve fwd) m	LCF from zero pt. (+ve fwd) m	KB m	BMt m	BML m	KMt m	KML m	Immersion (TPc) tonne/cm	MTc tonne.m
16,600	269807	16,666	-4,800	325,294	60,000	25083,337	16912,821	0,812	177,169	166,936	8,665	17,338	441,926	26,002	450,543	173,356	3556,270
16,800	273276	16,862	-4,800	325,927	60,000	25227,166	16941,629	0,812	177,037	166,707	8,768	17,145	438,607	25,912	447,327	173,652	3574,976
17,000	276752	17,059	-4,800	326,560	60,000	25371,657	16970,556	0,811	176,906	166,475	8,871	16,956	435,400	25,825	444,223	173,948	3594,025
17,200	280234	17,256	-4,800	327,193	60,000	25513,890	16997,257	0,810	176,775	166,266	8,974	16,771	432,042	25,743	440,969	174,222	3611,188
17,400	283721	17,452	-4,800	327,825	60,000	25658,458	17025,939	0,809	176,645	166,038	9,077	16,591	428,970	25,666	438,000	174,516	3630,221
17,600	287213	17,649	-4,800	333,986	60,000	25803,493	17054,917	0,794	176,514	165,807	9,180	16,414	426,003	25,593	435,136	174,813	3649,617
17,800	290712	17,845	-4,800	333,986	60,000	25948,515	17083,826	0,795	176,384	165,580	9,283	16,242	423,096	25,523	432,333	175,109	3669,014
18,000	294217	18,042	-4,800	333,986	60,000	26093,063	17112,325	0,796	176,254	165,363	9,386	16,074	420,208	25,458	429,548	175,401	3688,055
18,200	297728	18,239	-4,800	333,986	60,000	26237,733	17140,806	0,796	176,124	165,146	9,490	15,910	417,382	25,397	426,826	175,693	3707,135
18,400	301244	18,437	-4,800	333,986	60,000	26378,269	17165,092	0,797	175,995	164,973	9,593	15,749	414,210	25,340	423,758	175,942	3722,491
18,600	304765	18,633	-4,800	333,990	60,000	26526,204	17196,572	0,798	175,867	164,731	9,696	15,591	411,811	25,286	421,463	176,265	3744,501
18,800	308293	18,830	-4,800	334,003	60,000	26669,481	17225,584	0,798	175,738	164,514	9,800	15,436	409,255	25,234	419,010	176,562	3764,598
19,000	311827	19,027	-4,800	334,017	60,000	26815,398	17255,121	0,799	175,610	164,315	9,903	15,285	406,796	25,186	416,654	176,865	3785,159
19,200	315367	19,224	-4,800	334,030	60,000	26960,972	17284,221	0,800	175,482	164,130	10,007	15,135	404,353	25,140	414,316	177,163	3805,454
19,400	318912	19,422	-4,800	334,044	60,000	27101,986	17308,494	0,800	175,355	163,992	10,110	14,989	401,520	25,097	411,586	177,412	3821,459
19,600	322462	19,619	-4,800	334,058	60,000	27248,127	17337,071	0,801	175,229	163,814	10,214	14,845	399,162	25,057	409,332	177,705	3841,662
19,800	326019	19,817	-4,800	334,071	60,000	27392,191	17363,081	0,801	175,104	163,668	10,318	14,703	396,617	25,019	406,891	177,972	3859,559
20,000	329580	20,015	-4,800	334,103	60,000	27535,396	17387,769	0,802	174,979	163,538	10,421	14,564	394,013	24,984	404,391	178,225	3876,384
20,200	333147	20,214	-4,800	334,159	60,000	27678,076	17411,623	0,803	174,856	163,419	10,525	14,428	391,392	24,952	401,874	178,469	3892,549
20,400	336718	20,412	-4,800	334,215	60,000	27820,445	17434,902	0,803	174,734	163,308	10,629	14,294	388,782	24,921	399,369	178,708	3908,334
20,600	340295	20,610	-4,800	334,271	60,000	27962,719	17457,937	0,804	174,614	163,205	10,733	14,163	386,206	24,894	396,897	178,944	3923,975
20,800	343875	20,809	-4,800	334,327	60,000	28104,926	17480,729	0,804	174,494	163,104	10,837	14,034	383,663	24,869	394,458	179,177	3939,478
21,000	347461	21,008	-4,800	334,383	60,000	28246,838	17502,907	0,805	174,376	163,009	10,941	13,907	381,127	24,846	392,026	179,405	3954,569
21,200	351051	21,206	-4,800	334,439	60,000	28388,540	17524,648	0,805	174,260	162,918	11,045	13,783	378,606	24,826	389,610	179,628	3969,342
21,400	354645	21,405	-4,800	334,495	60,000	28530,140	17546,048	0,806	174,144	162,830	11,149	13,661	376,112	24,808	387,220	179,847	3983,924
21,600	358244	21,604	-4,800	334,551	60,000	28671,684	17567,262	0,806	174,030	162,749	11,253	13,541	373,654	24,792	384,866	180,064	3998,420
21,800	361847	21,803	-4,800	334,607	60,000	28813,145	17588,233	0,807	173,917	162,671	11,357	13,423	371,222	24,779	382,539	180,279	4012,737
22,000	365454	22,001	-4,800	334,663	60,000	28954,429	17608,874	0,807	173,806	162,599	11,461	13,308	368,812	24,767	380,233	180,491	4026,825
22,200	369066	22,200	-4,800	334,719	60,000	29095,644	17629,276	0,808	173,696	162,525	11,565	13,195	366,429	24,758	377,954	180,700	4040,756
22,400	372681	22,399	-4,800	334,784	60,000	29236,629	17649,223	0,808	173,587	162,455	11,669	13,083	364,057	24,751	375,686	180,905	4054,354
22,600	376301	22,598	-4,800	334,849	60,000	29377,639	17669,131	0,809	173,480	162,387	11,774	12,975	361,721	24,747	373,455	181,109	4067,916

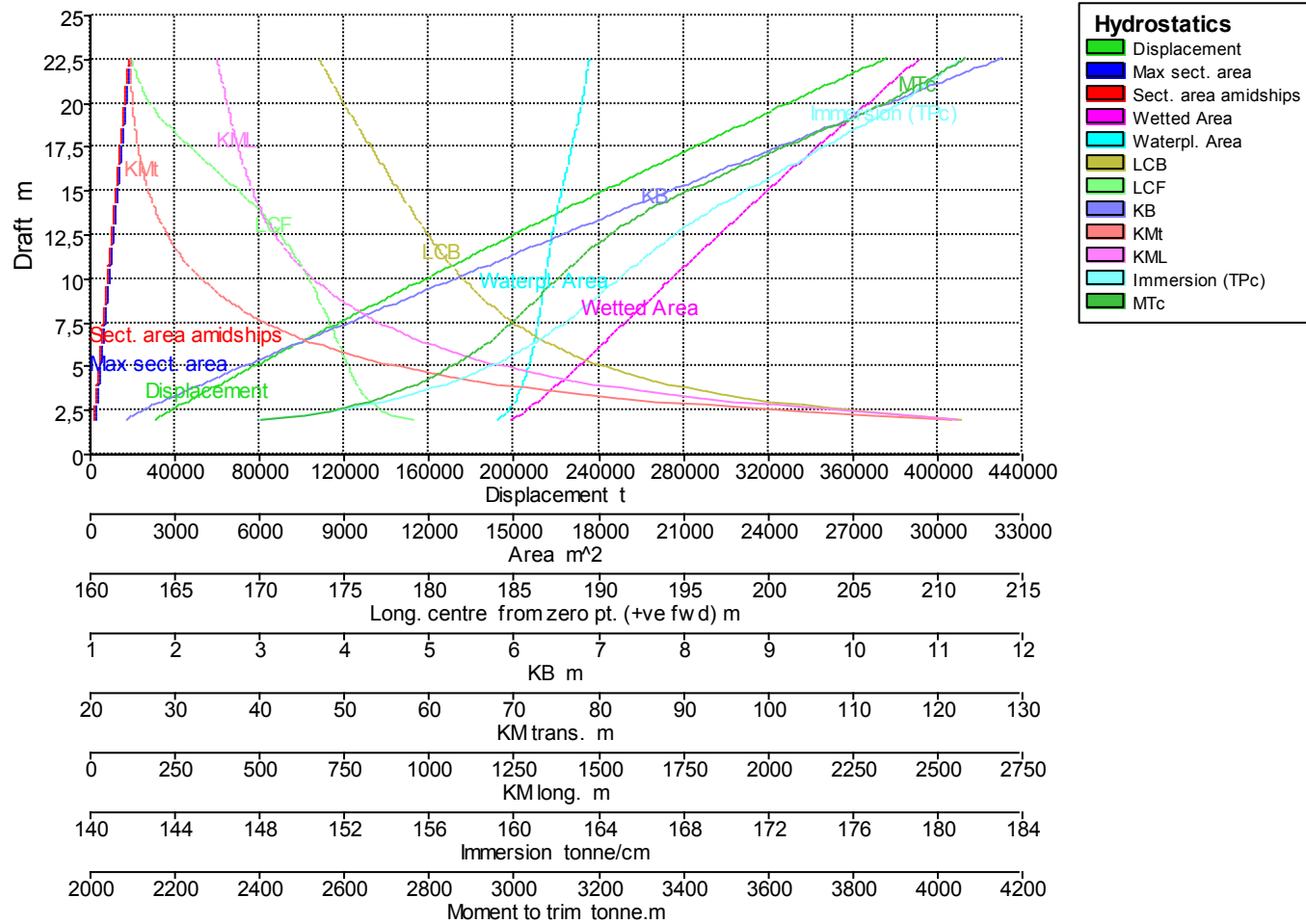

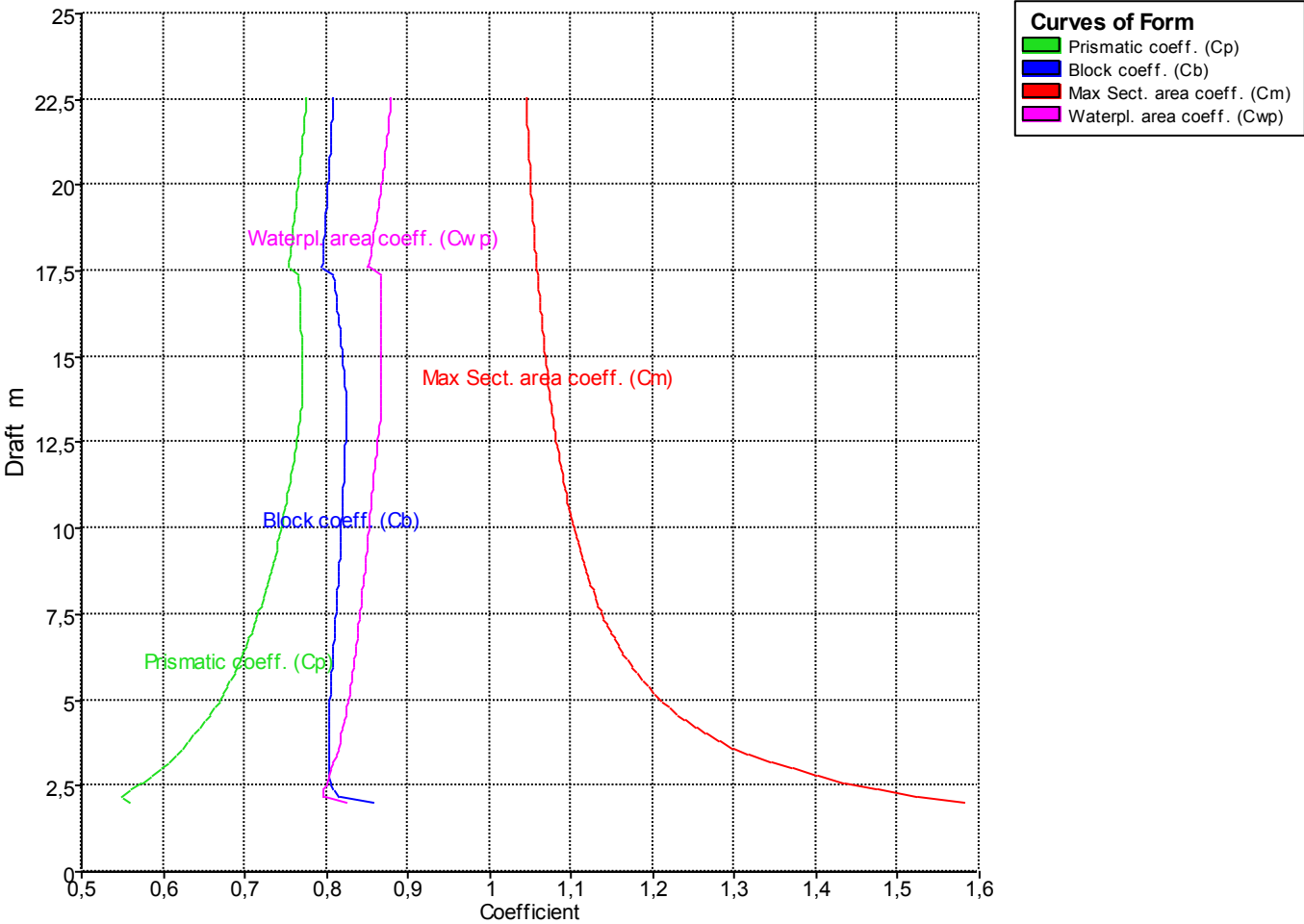

11 CURVAS DE KN.

Los valores del par adrizante se calculan para diversos ángulos de escora, y una serie de desplazamientos que comprenden los desplazamientos más probables del buque, añadiendo cierto margen. El valor de este brazo no depende solo de las formas del buque, sino también del KG del buque.

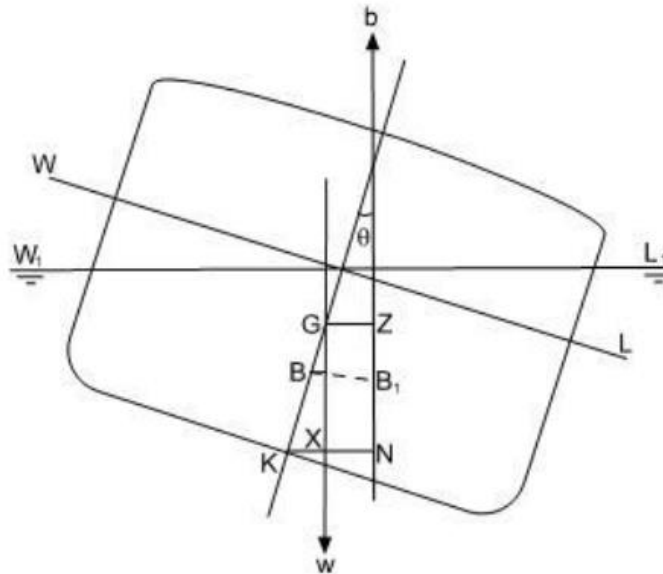

Los ángulos de escora los estudiaremos de 5° a 40° en intervalos de 5° en la etapa inicial, para después llegar hasta 70° en intervalos de 10° . Además, cabe destacar que habrá nuevamente variación de trimados y será de forma análoga a las curvas hidrostáticas.

A continuación, vemos todos los parámetros calculados por MAXSURF Stability y las curvas correspondientes.

Para un trimado de 0 m:

Displacement (intact) tonne	Draft Amidships m	Trim (+ve by stern) m	TCG m	KN 5,0 deg. Starb.	KN 10,0 deg. Starb.	KN 15,0 deg. Starb.	KN 20,0 deg. Starb.	KN 25,0 deg. Starb.	KN 30,0 deg. Starb.	KN 35,0 deg. Starb.	KN 40,0 deg. Starb.	KN 50,0 deg. Starb.	KN 60,0 deg. Starb.	KN 70,0 deg. Starb.
28057	2,000	0,000	0,000	10,902	16,138	18,659	20,095	20,926	21,355	21,482	21,367	20,578	19,308	18,047
31059	2,200	0,000	0,000	10,187	15,578	18,208	19,736	20,646	21,144	21,339	21,289	20,628	19,489	18,381
34081	2,400	0,000	0,000	9,526	15,049	17,779	19,394	20,377	20,944	21,202	21,214	20,675	19,663	18,699
37121	2,600	0,000	0,000	8,921	14,547	17,372	19,066	20,121	20,752	21,071	21,141	20,719	19,829	18,999
40178	2,800	0,000	0,000	8,374	14,070	16,982	18,751	19,875	20,568	20,945	21,072	20,761	19,987	19,254
43250	3,000	0,000	0,000	7,891	13,614	16,609	18,448	19,638	20,390	20,824	21,005	20,801	20,140	19,467
46335	3,200	0,000	0,000	7,463	13,179	16,252	18,157	19,409	20,219	20,706	20,939	20,841	20,287	19,646
49433	3,400	0,000	0,000	7,081	12,761	15,909	17,876	19,187	20,054	20,593	20,876	20,878	20,431	19,796
52543	3,600	0,000	0,000	6,738	12,359	15,578	17,605	18,972	19,893	20,482	20,815	20,915	20,568	19,921
55662	3,800	0,000	0,000	6,429	11,973	15,259	17,343	18,764	19,737	20,375	20,756	20,950	20,702	20,027
58793	4,000	0,000	0,000	6,149	11,602	14,951	17,091	18,561	19,585	20,271	20,698	20,983	20,832	20,112
61933	4,200	0,000	0,000	5,893	11,242	14,653	16,846	18,365	19,436	20,170	20,641	21,018	20,957	20,188
65082	4,400	0,000	0,000	5,660	10,896	14,365	16,609	18,175	19,292	20,071	20,586	21,047	21,066	20,248
68241	4,600	0,000	0,000	5,446	10,562	14,085	16,378	17,990	19,150	19,975	20,533	21,081	21,157	20,290
71409	4,800	0,000	0,000	5,250	10,242	13,813	16,154	17,810	19,013	19,880	20,481	21,113	21,234	20,335
74586	5,000	0,000	0,000	5,068	9,935	13,549	15,936	17,635	18,879	19,787	20,430	21,143	21,297	20,363
77770	5,200	0,000	0,000	4,901	9,640	13,292	15,725	17,464	18,748	19,697	20,380	21,173	21,348	20,389
80962	5,400	0,000	0,000	4,745	9,360	13,043	15,518	17,298	18,620	19,608	20,331	21,202	21,393	20,396
84162	5,600	0,000	0,000	4,600	9,097	12,800	15,317	17,135	18,495	19,521	20,283	21,230	21,417	20,415
87369	5,800	0,000	0,000	4,466	8,851	12,563	15,120	16,977	18,374	19,435	20,235	21,259	21,440	20,413
90582	6,000	0,000	0,000	4,340	8,619	12,331	14,929	16,823	18,255	19,352	20,189	21,286	21,441	20,419
93803	6,200	0,000	0,000	4,223	8,400	12,106	14,742	16,671	18,138	19,269	20,143	21,312	21,461	20,412
97030	6,400	0,000	0,000	4,113	8,194	11,885	14,559	16,524	18,024	19,190	20,098	21,334	21,462	20,405
100264	6,600	0,000	0,000	4,011	7,999	11,670	14,380	16,379	17,913	19,112	20,052	21,349	21,457	20,386
103504	6,800	0,000	0,000	3,915	7,816	11,460	14,205	16,238	17,805	19,036	20,008	21,355	21,447	20,378
106749	7,000	0,000	0,000	3,824	7,643	11,256	14,033	16,099	17,698	18,961	19,968	21,354	21,430	20,372
109999	7,200	0,000	0,000	3,739	7,479	11,057	13,866	15,963	17,594	18,887	19,925	21,347	21,408	20,342
113255	7,400	0,000	0,000	3,659	7,324	10,863	13,701	15,830	17,492	18,816	19,885	21,334	21,385	20,317
116517	7,600	0,000	0,000	3,584	7,177	10,675	13,540	15,700	17,391	18,746	19,846	21,315	21,369	20,289
119784	7,800	0,000	0,000	3,513	7,038	10,491	13,382	15,572	17,293	18,676	19,806	21,292	21,338	20,241
123055	8,000	0,000	0,000	3,445	6,906	10,314	13,227	15,447	17,197	18,609	19,768	21,264	21,292	20,232
126333	8,200	0,000	0,000	3,382	6,781	10,144	13,075	15,324	17,102	18,543	19,729	21,231	21,259	20,197
129615	8,400	0,000	0,000	3,321	6,662	9,982	12,926	15,203	17,009	18,478	19,693	21,195	21,221	20,175
132902	8,600	0,000	0,000	3,264	6,550	9,826	12,779	15,085	16,918	18,414	19,657	21,153	21,179	20,141
136194	8,800	0,000	0,000	3,210	6,443	9,676	12,636	14,968	16,828	18,353	19,623	21,094	21,134	20,099
139492	9,000	0,000	0,000	3,159	6,341	9,533	12,495	14,854	16,740	18,288	19,588	21,062	21,072	20,053
142794	9,200	0,000	0,000	3,110	6,245	9,396	12,356	14,741	16,654	18,231	19,552	21,013	21,041	20,025

PETROLERO VLCC DE 300.000 TPM

CUADERNO IV: COMPARTIMENTADO Y CÁLCULOS DE ARQUITECTURA NAVAL

PEDRO LEMOS GONZÁLEZ

Displacement (intact) tonne	Draft Amidships m	Trim (+ve by stern) m	TCG m	KN 5,0 deg. Starb.	KN 10,0 deg. Starb.	KN 15,0 deg. Starb.	KN 20,0 deg. Starb.	KN 25,0 deg. Starb.	KN 30,0 deg. Starb.	KN 35,0 deg. Starb.	KN 40,0 deg. Starb.	KN 50,0 deg. Starb.	KN 60,0 deg. Starb.	KN 70,0 deg. Starb.
146102	9,400	0,000	0,000	3,064	6,153	9,265	12,220	14,630	16,569	18,171	19,514	20,959	20,981	19,994
149414	9,600	0,000	0,000	3,020	6,065	9,139	12,087	14,521	16,486	18,114	19,472	20,902	20,924	19,951
152732	9,800	0,000	0,000	2,978	5,982	9,018	11,956	14,414	16,404	18,056	19,428	20,833	20,868	19,918
156055	10,000	0,000	0,000	2,938	5,903	8,903	11,829	14,309	16,323	18,001	19,380	20,782	20,822	19,882
159383	10,200	0,000	0,000	2,900	5,827	8,792	11,703	14,205	16,244	17,946	19,329	20,721	20,765	19,840
162717	10,400	0,000	0,000	2,864	5,755	8,686	11,581	14,103	16,165	17,892	19,275	20,677	20,715	19,792
166056	10,600	0,000	0,000	2,830	5,687	8,584	11,461	14,003	16,089	17,838	19,219	20,590	20,635	19,754
169399	10,800	0,000	0,000	2,798	5,621	8,487	11,344	13,904	16,013	17,786	19,160	20,517	20,597	19,701
172749	11,000	0,000	0,000	2,766	5,559	8,394	11,231	13,806	15,938	17,735	19,099	20,456	20,529	19,653
176103	11,200	0,000	0,000	2,737	5,499	8,304	11,122	13,710	15,865	17,682	19,038	20,395	20,471	19,631
179463	11,400	0,000	0,000	2,708	5,442	8,219	11,016	13,616	15,793	17,627	18,970	20,325	20,385	19,593
182828	11,600	0,000	0,000	2,681	5,388	8,137	10,914	13,523	15,722	17,569	18,902	20,237	20,347	19,559
186199	11,800	0,000	0,000	2,656	5,336	8,059	10,816	13,431	15,652	17,510	18,833	20,166	20,281	19,500
189576	12,000	0,000	0,000	2,631	5,286	7,983	10,720	13,341	15,583	17,449	18,761	20,090	20,222	19,449
192959	12,200	0,000	0,000	2,608	5,238	7,912	10,629	13,252	15,515	17,385	18,690	20,013	20,154	19,386
196349	12,400	0,000	0,000	2,585	5,193	7,843	10,540	13,165	15,448	17,320	18,614	19,936	20,093	19,343
199745	12,600	0,000	0,000	2,564	5,149	7,777	10,454	13,079	15,383	17,253	18,534	19,874	20,017	19,280
203147	12,800	0,000	0,000	2,543	5,108	7,713	10,372	12,995	15,317	17,182	18,461	19,782	19,963	19,241
206556	13,000	0,000	0,000	2,524	5,068	7,653	10,293	12,912	15,253	17,112	18,380	19,700	19,909	19,207
209971	13,200	0,000	0,000	2,505	5,030	7,595	10,216	12,831	15,189	17,041	18,300	19,625	19,812	19,137
213393	13,400	0,000	0,000	2,487	4,993	7,539	10,142	12,751	15,126	16,966	18,225	19,559	19,759	19,131
216821	13,600	0,000	0,000	2,470	4,959	7,486	10,071	12,673	15,063	16,888	18,135	19,444	19,697	19,026
220255	13,800	0,000	0,000	2,454	4,925	7,435	10,003	12,596	14,997	16,809	18,049	19,375	19,622	19,000
223696	14,000	0,000	0,000	2,438	4,893	7,386	9,937	12,522	14,930	16,728	17,966	19,282	19,560	18,928
227143	14,200	0,000	0,000	2,423	4,863	7,339	9,874	12,450	14,862	16,648	17,888	19,214	19,490	18,872
230597	14,400	0,000	0,000	2,409	4,834	7,294	9,813	12,380	14,792	16,565	17,794	19,183	19,402	18,973
234057	14,600	0,000	0,000	2,395	4,806	7,251	9,755	12,313	14,720	16,483	17,702	19,043	19,351	18,788
237524	14,800	0,000	0,000	2,382	4,779	7,210	9,699	12,247	14,647	16,398	17,613	18,965	19,273	18,736
240997	15,000	0,000	0,000	2,369	4,753	7,171	9,646	12,183	14,572	16,309	17,523	18,863	19,195	18,683
244476	15,200	0,000	0,000	2,357	4,728	7,133	9,594	12,122	14,496	16,225	17,430	18,790	19,135	18,630
247962	15,400	0,000	0,000	2,346	4,705	7,097	9,545	12,062	14,418	16,132	17,337	18,705	19,045	18,577
251454	15,600	0,000	0,000	2,335	4,682	7,063	9,498	12,005	14,339	16,044	17,246	18,626	18,979	18,524
254951	15,800	0,000	0,000	2,324	4,661	7,030	9,453	11,950	14,259	15,961	17,148	18,529	18,913	18,471
258454	16,000	0,000	0,000	2,314	4,640	6,998	9,410	11,896	14,177	15,862	17,065	18,454	18,819	18,418
261963	16,200	0,000	0,000	2,304	4,621	6,968	9,368	11,844	14,096	15,769	16,955	18,356	18,761	18,366
265478	16,400	0,000	0,000	2,295	4,602	6,939	9,329	11,794	14,012	15,675	16,874	18,232	18,687	18,313
268999	16,600	0,000	0,000	2,286	4,584	6,912	9,291	11,743	13,928	15,580	16,768	18,216	18,613	18,259
272526	16,800	0,000	0,000	2,278	4,567	6,885	9,255	11,692	13,843	15,484	16,669	18,104	18,539	18,206
276058	17,000	0,000	0,000	2,270	4,551	6,860	9,220	11,641	13,757	15,391	16,569	17,997	18,464	18,152
279595	17,200	0,000	0,000	2,262	4,536	6,836	9,187	11,589	13,672	15,291	16,467	17,961	18,389	18,098

PETROLERO VLCC DE 300.000 TPM

CUADERNO IV: COMPARTIMENTADO Y CÁLCULOS DE ARQUITECTURA NAVAL

PEDRO LEMOS GONZÁLEZ

Displacement (intact) tonne	Draft Amidships m	Trim (+ve by stern) m	TCG m	KN 5,0 deg. Starb.	KN 10,0 deg. Starb.	KN 15,0 deg. Starb.	KN 20,0 deg. Starb.	KN 25,0 deg. Starb.	KN 30,0 deg. Starb.	KN 35,0 deg. Starb.	KN 40,0 deg. Starb.	KN 50,0 deg. Starb.	KN 60,0 deg. Starb.	KN 70,0 deg. Starb.
283138	17,400	0,000	0,000	2,255	4,521	6,814	9,156	11,536	13,587	15,192	16,377	17,816	18,315	18,044
286685	17,600	0,000	0,000	2,248	4,507	6,792	9,126	11,484	13,498	15,093	16,277	17,743	18,240	17,990
290237	17,800	0,000	0,000	2,241	4,493	6,772	9,097	11,430	13,414	14,991	16,187	17,985	18,165	17,935
293793	18,000	0,000	0,000	2,234	4,481	6,752	9,070	11,375	13,327	14,916	16,080	17,548	18,089	17,881
297353	18,200	0,000	0,000	2,228	4,469	6,733	9,045	11,322	13,240	14,793	15,984	17,452	18,012	17,826
300917	18,400	0,000	0,000	2,223	4,457	6,716	9,020	11,266	13,154	14,693	15,874	17,367	17,936	17,772
304485	18,600	0,000	0,000	2,217	4,446	6,699	8,997	11,210	13,068	14,590	15,779	17,273	17,859	17,717
308056	18,800	0,000	0,000	2,212	4,436	6,683	8,975	11,154	12,981	14,491	15,673	17,181	17,781	17,662
311632	19,000	0,000	0,000	2,207	4,426	6,668	8,954	11,098	12,896	14,391	15,572	17,087	17,704	17,575
315210	19,200	0,000	0,000	2,203	4,417	6,654	8,935	11,044	12,808	14,286	15,465	16,993	17,626	17,520
318793	19,400	0,000	0,000	2,199	4,408	6,641	8,915	10,983	12,718	14,189	15,370	16,897	17,549	17,465
322378	19,600	0,000	0,000	2,195	4,400	6,628	8,894	10,925	12,635	14,089	15,268	16,801	17,471	17,409
325967	19,800	0,000	0,000	2,191	4,392	6,617	8,872	10,868	12,547	13,994	15,131	16,705	17,392	17,354
329559	20,000	0,000	0,000	2,187	4,385	6,606	8,848	10,809	12,464	13,888	15,057	16,608	17,314	17,298
333155	20,200	0,000	0,000	2,184	4,379	6,595	8,823	10,748	12,378	13,787	14,957	16,511	17,235	17,242
336753	20,400	0,000	0,000	2,181	4,372	6,586	8,796	10,687	12,288	13,688	14,852	16,414	17,156	17,187
340355	20,600	0,000	0,000	2,178	4,367	6,577	8,767	10,627	12,212	13,585	14,745	16,316	17,077	17,131
343960	20,800	0,000	0,000	2,175	4,361	6,569	8,737	10,565	12,122	13,495	14,637	16,218	16,998	17,075
347569	21,000	0,000	0,000	2,173	4,356	6,561	8,705	10,505	12,042	13,389	14,530	16,119	16,919	17,020
351180	21,200	0,000	0,000	2,171	4,352	6,554	8,672	10,440	11,958	13,291	14,422	16,020	16,839	16,964
354795	21,400	0,000	0,000	2,169	4,348	6,548	8,638	10,382	11,877	13,192	14,314	15,921	16,724	16,908
358413	21,600	0,000	0,000	2,167	4,344	6,542	8,602	10,315	11,795	13,094	14,207	15,821	16,644	16,852
362035	21,800	0,000	0,000	2,166	4,341	6,537	8,564	10,250	11,737	12,996	14,100	15,721	16,563	16,796
365660	22,000	0,000	0,000	2,164	4,338	6,533	8,525	10,182	11,628	12,899	13,993	15,621	16,482	16,740
369288	22,200	0,000	0,000	2,163	4,335	6,527	8,485	10,117	11,545	12,801	13,886	15,521	16,401	16,684
372919	22,400	0,000	0,000	2,162	4,333	6,520	8,443	10,055	11,462	12,703	13,780	15,420	16,320	16,628
376553	22,600	0,000	0,000	2,162	4,331	6,511	8,398	9,986	11,380	12,606	13,674	15,319	16,239	16,572

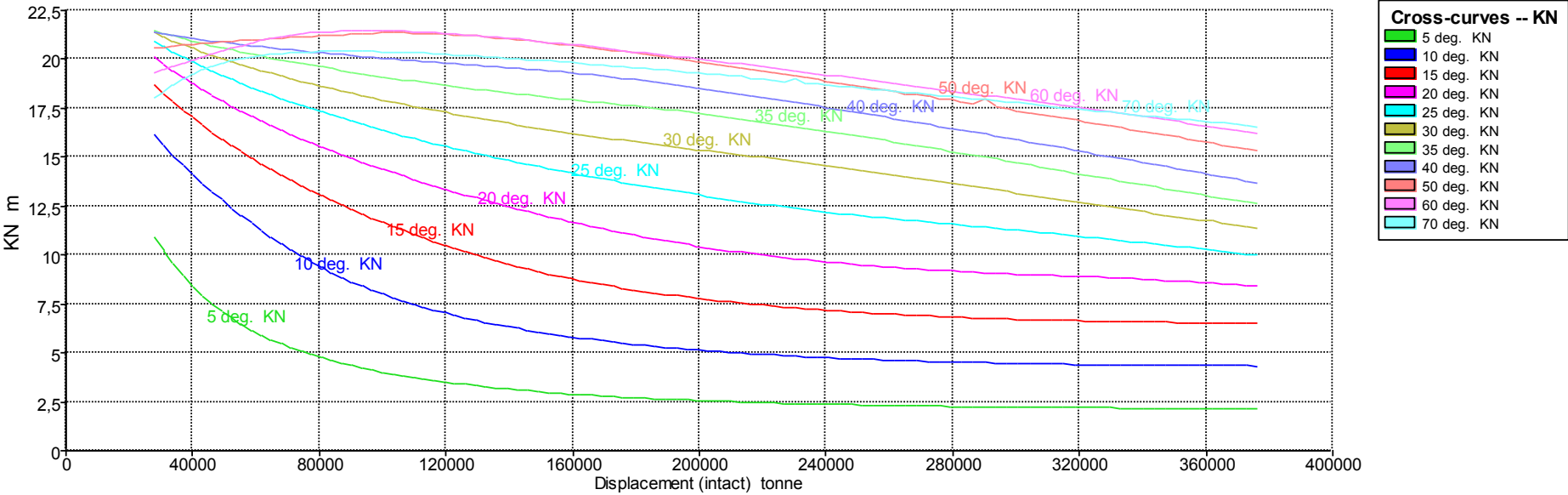

- Para un trimado de 1,6 m:

Displacement (intact) tonne	Draft Amidships m	Trim (+ve by stern) m	TCG m	KN 5,0 deg. Starb.	KN 10,0 deg. Starb.	KN 15,0 deg. Starb.	KN 20,0 deg. Starb.	KN 25,0 deg. Starb.	KN 30,0 deg. Starb.	KN 35,0 deg. Starb.	KN 40,0 deg. Starb.	KN 50,0 deg. Starb.	KN 60,0 deg. Starb.	KN 70,0 deg. Starb.
27418	2,000	1,600	0,000	10,916	16,001	18,485	19,942	20,811	21,273	21,434	21,352	20,625	19,407	18,187
30408	2,200	1,600	0,000	10,235	15,481	18,070	19,608	20,549	21,079	21,302	21,280	20,671	19,576	18,494
33418	2,400	1,600	0,000	9,597	14,985	17,672	19,286	20,296	20,890	21,174	21,210	20,718	19,739	18,782
36447	2,600	1,600	0,000	9,006	14,510	17,289	18,976	20,051	20,708	21,050	21,142	20,758	19,896	19,046
39492	2,800	1,600	0,000	8,466	14,055	16,920	18,677	19,815	20,532	20,929	21,075	20,799	20,048	19,282
42552	3,000	1,600	0,000	7,978	13,617	16,565	18,390	19,587	20,361	20,812	21,010	20,838	20,195	19,490
45627	3,200	1,600	0,000	7,543	13,195	16,223	18,111	19,366	20,195	20,698	20,947	20,874	20,337	19,669
48715	3,400	1,600	0,000	7,155	12,789	15,892	17,842	19,152	20,033	20,588	20,885	20,909	20,475	19,820
51816	3,600	1,600	0,000	6,807	12,398	15,572	17,582	18,945	19,876	20,480	20,825	20,946	20,609	19,946
54929	3,800	1,600	0,000	6,492	12,019	15,263	17,330	18,743	19,723	20,375	20,767	20,979	20,739	20,052
58053	4,000	1,600	0,000	6,207	11,654	14,963	17,084	18,548	19,574	20,273	20,710	21,011	20,862	20,141
61188	4,200	1,600	0,000	5,949	11,300	14,673	16,846	18,358	19,430	20,173	20,655	21,043	20,976	20,215
64333	4,400	1,600	0,000	5,712	10,957	14,391	16,614	18,173	19,288	20,075	20,601	21,074	21,080	20,275
67486	4,600	1,600	0,000	5,495	10,627	14,116	16,390	17,993	19,151	19,980	20,547	21,104	21,171	20,328
70649	4,800	1,600	0,000	5,295	10,309	13,850	16,171	17,817	19,017	19,887	20,495	21,111	21,248	20,364
73821	5,000	1,600	0,000	5,111	10,002	13,590	15,958	17,646	18,886	19,795	20,444	21,163	21,312	20,395
77001	5,200	1,600	0,000	4,941	9,708	13,337	15,750	17,479	18,758	19,706	20,394	21,192	21,364	20,417
80190	5,400	1,600	0,000	4,784	9,428	13,091	15,548	17,316	18,633	19,619	20,345	21,220	21,408	20,434
83386	5,600	1,600	0,000	4,637	9,163	12,850	15,349	17,157	18,510	19,533	20,297	21,248	21,438	20,442
86590	5,800	1,600	0,000	4,501	8,915	12,616	15,156	17,001	18,391	19,449	20,249	21,275	21,459	20,449
89801	6,000	1,600	0,000	4,374	8,680	12,387	14,968	16,849	18,274	19,367	20,203	21,302	21,475	20,444
93020	6,200	1,600	0,000	4,256	8,460	12,162	14,783	16,700	18,160	19,287	20,157	21,326	21,483	20,443
96246	6,400	1,600	0,000	4,145	8,251	11,943	14,602	16,554	18,048	19,208	20,113	21,346	21,484	20,434
99480	6,600	1,600	0,000	4,041	8,055	11,730	14,425	16,412	17,938	19,131	20,068	21,359	21,480	20,424
102720	6,800	1,600	0,000	3,943	7,870	11,521	14,252	16,272	17,831	19,055	20,025	21,367	21,470	20,405
105966	7,000	1,600	0,000	3,852	7,695	11,317	14,081	16,135	17,725	18,981	19,983	21,368	21,457	20,390
109220	7,200	1,600	0,000	3,766	7,529	11,118	13,915	16,001	17,622	18,909	19,938	21,362	21,436	20,360
112479	7,400	1,600	0,000	3,685	7,373	10,924	13,752	15,869	17,521	18,838	19,900	21,350	21,415	20,345
115745	7,600	1,600	0,000	3,609	7,224	10,735	13,591	15,740	17,421	18,768	19,858	21,333	21,384	20,318
119014	7,800	1,600	0,000	3,537	7,084	10,552	13,434	15,613	17,324	18,699	19,822	21,310	21,355	20,293
122290	8,000	1,600	0,000	3,469	6,951	10,374	13,280	15,489	17,228	18,632	19,783	21,282	21,322	20,264
125571	8,200	1,600	0,000	3,404	6,825	10,203	13,128	15,367	17,134	18,566	19,747	21,249	21,283	20,226
128858	8,400	1,600	0,000	3,343	6,705	10,039	12,980	15,246	17,042	18,502	19,710	21,214	21,246	20,198
132151	8,600	1,600	0,000	3,286	6,591	9,882	12,833	15,128	16,952	18,438	19,674	21,172	21,204	20,162
135449	8,800	1,600	0,000	3,231	6,483	9,731	12,690	15,012	16,863	18,376	19,639	21,131	21,160	20,131

PETROLERO VLCC DE 300.000 TPM

CUADERNO IV: COMPARTIMENTADO Y CÁLCULOS DE ARQUITECTURA NAVAL

PEDRO LEMOS GONZÁLEZ

Displacement (intact) tonne	Draft Amidships m	Trim (+ve by stern) m	TCG m	KN 5,0 deg. Starb.	KN 10,0 deg. Starb.	KN 15,0 deg. Starb.	KN 20,0 deg. Starb.	KN 25,0 deg. Starb.	KN 30,0 deg. Starb.	KN 35,0 deg. Starb.	KN 40,0 deg. Starb.	KN 50,0 deg. Starb.	KN 60,0 deg. Starb.	KN 70,0 deg. Starb.
138753	9,000	1,600	0,000	3,179	6,380	9,587	12,549	14,898	16,775	18,313	19,605	21,084	21,114	20,094
142063	9,200	1,600	0,000	3,130	6,283	9,448	12,410	14,786	16,689	18,255	19,570	21,034	21,065	20,044
145379	9,400	1,600	0,000	3,083	6,190	9,316	12,274	14,676	16,604	18,197	19,533	20,981	21,004	20,037
148701	9,600	1,600	0,000	3,038	6,101	9,189	12,140	14,567	16,521	18,139	19,493	20,925	20,963	19,986
152028	9,800	1,600	0,000	2,996	6,017	9,067	12,010	14,460	16,439	18,082	19,449	20,867	20,908	19,942
155361	10,000	1,600	0,000	2,956	5,937	8,950	11,881	14,355	16,359	18,027	19,402	20,809	20,845	19,900
158700	10,200	1,600	0,000	2,918	5,861	8,838	11,755	14,251	16,279	17,972	19,353	20,746	20,798	19,865
162045	10,400	1,600	0,000	2,881	5,788	8,731	11,632	14,149	16,201	17,918	19,300	20,697	20,737	19,860
165395	10,600	1,600	0,000	2,847	5,718	8,628	11,511	14,048	16,125	17,865	19,245	20,613	20,646	19,793
168750	10,800	1,600	0,000	2,814	5,652	8,530	11,394	13,949	16,049	17,813	19,187	20,551	20,618	19,726
172112	11,000	1,600	0,000	2,782	5,589	8,435	11,280	13,851	15,974	17,762	19,126	20,482	20,557	19,699
175479	11,200	1,600	0,000	2,752	5,528	8,345	11,170	13,755	15,901	17,710	19,064	20,411	20,498	19,660
178854	11,400	1,600	0,000	2,723	5,471	8,258	11,063	13,660	15,829	17,657	19,000	20,341	20,436	19,590
182235	11,600	1,600	0,000	2,696	5,415	8,175	10,960	13,567	15,758	17,601	18,933	20,267	20,373	19,559
185623	11,800	1,600	0,000	2,670	5,363	8,096	10,860	13,475	15,687	17,542	18,864	20,191	20,292	19,524
189016	12,000	1,600	0,000	2,645	5,312	8,020	10,764	13,384	15,619	17,482	18,793	20,117	20,245	19,481
192417	12,200	1,600	0,000	2,621	5,264	7,947	10,671	13,295	15,550	17,419	18,720	20,042	20,179	19,428
195825	12,400	1,600	0,000	2,598	5,218	7,877	10,581	13,207	15,483	17,353	18,645	19,968	20,111	19,372
199239	12,600	1,600	0,000	2,577	5,173	7,810	10,495	13,120	15,416	17,286	18,570	19,890	20,052	19,325
202660	12,800	1,600	0,000	2,556	5,131	7,746	10,411	13,035	15,351	17,217	18,492	19,791	19,982	19,286
206087	13,000	1,600	0,000	2,536	5,091	7,684	10,331	12,952	15,286	17,146	18,412	19,731	19,905	19,248
209521	13,200	1,600	0,000	2,517	5,052	7,626	10,253	12,870	15,223	17,073	18,332	19,651	19,854	19,173
212962	13,400	1,600	0,000	2,499	5,015	7,569	10,178	12,789	15,160	16,998	18,250	19,579	19,776	19,113
216409	13,600	1,600	0,000	2,481	4,979	7,515	10,106	12,710	15,097	16,921	18,167	19,482	19,719	19,064
219863	13,800	1,600	0,000	2,464	4,945	7,463	10,037	12,633	15,032	16,843	18,080	19,400	19,648	18,929
223323	14,000	1,600	0,000	2,448	4,913	7,414	9,970	12,558	14,965	16,763	17,996	19,320	19,585	18,909
226790	14,200	1,600	0,000	2,433	4,882	7,366	9,906	12,485	14,896	16,682	17,928	19,240	19,508	18,909
230264	14,400	1,600	0,000	2,418	4,852	7,320	9,845	12,414	14,826	16,599	17,822	19,157	19,444	18,911
233745	14,600	1,600	0,000	2,404	4,823	7,277	9,786	12,345	14,754	16,515	17,734	19,070	19,372	18,810
237231	14,800	1,600	0,000	2,391	4,796	7,235	9,729	12,279	14,681	16,429	17,640	18,988	19,294	18,754
240724	15,000	1,600	0,000	2,378	4,770	7,195	9,675	12,214	14,605	16,343	17,551	18,904	19,225	18,687
244222	15,200	1,600	0,000	2,366	4,744	7,156	9,623	12,152	14,529	16,255	17,460	18,827	19,146	18,647
247727	15,400	1,600	0,000	2,354	4,720	7,119	9,572	12,092	14,451	16,166	17,369	18,732	19,090	18,594
251238	15,600	1,600	0,000	2,342	4,698	7,084	9,525	12,034	14,372	16,077	17,276	18,654	19,002	18,541
254755	15,800	1,600	0,000	2,332	4,676	7,051	9,479	11,978	14,291	15,985	17,203	18,548	18,944	18,488
258277	16,000	1,600	0,000	2,321	4,655	7,018	9,435	11,924	14,210	15,895	17,084	18,485	18,864	18,434
261805	16,200	1,600	0,000	2,311	4,635	6,988	9,393	11,871	14,127	15,800	16,994	18,414	18,782	18,381
265338	16,400	1,600	0,000	2,302	4,615	6,958	9,352	11,820	14,043	15,710	16,916	18,303	18,714	18,327
268877	16,600	1,600	0,000	2,293	4,597	6,930	9,314	11,769	13,958	15,609	16,810	18,194	18,622	18,274
272420	16,800	1,600	0,000	2,284	4,580	6,903	9,277	11,718	13,872	15,512	16,698	18,123	18,566	18,220

PETROLERO VLCC DE 300.000 TPM

CUADERNO IV: COMPARTIMENTADO Y CÁLCULOS DE ARQUITECTURA NAVAL

PEDRO LEMOS GONZÁLEZ

Displacement (intact) tonne	Draft Amidships m	Trim (+ve by stern) m	TCG m	KN 5,0 deg. Starb.	KN 10,0 deg. Starb.	KN 15,0 deg. Starb.	KN 20,0 deg. Starb.	KN 25,0 deg. Starb.	KN 30,0 deg. Starb.	KN 35,0 deg. Starb.	KN 40,0 deg. Starb.	KN 50,0 deg. Starb.	KN 60,0 deg. Starb.	KN 70,0 deg. Starb.
275968	17,000	1,600	0,000	2,275	4,563	6,878	9,242	11,666	13,786	15,417	16,600	18,019	18,485	18,167
279521	17,200	1,600	0,000	2,268	4,547	6,853	9,208	11,613	13,700	15,321	16,505	17,935	18,410	18,113
283077	17,400	1,600	0,000	2,260	4,532	6,830	9,176	11,560	13,614	15,223	16,407	17,842	18,334	18,060
286638	17,600	1,600	0,000	2,253	4,517	6,808	9,146	11,506	13,527	15,120	16,308	17,767	18,258	18,006
290203	17,800	1,600	0,000	2,246	4,504	6,787	9,116	11,452	13,439	15,013	16,210	17,670	18,182	17,951
293771	18,000	1,600	0,000	2,239	4,491	6,767	9,089	11,398	13,352	14,923	16,114	17,593	18,106	17,897
297343	18,200	1,600	0,000	2,233	4,478	6,748	9,062	11,343	13,270	14,820	16,010	17,470	18,031	17,842
300919	18,400	1,600	0,000	2,227	4,466	6,730	9,038	11,287	13,179	14,721	15,909	17,385	17,955	17,788
304498	18,600	1,600	0,000	2,222	4,455	6,712	9,014	11,230	13,091	14,621	15,812	17,301	17,878	17,733
308081	18,800	1,600	0,000	2,216	4,444	6,696	8,991	11,174	13,007	14,531	15,695	17,204	17,801	17,678
311667	19,000	1,600	0,000	2,211	4,434	6,681	8,970	11,117	12,916	14,418	15,603	17,106	17,723	17,623
315256	19,200	1,600	0,000	2,207	4,425	6,666	8,949	11,059	12,828	14,322	15,497	17,011	17,646	17,568
318848	19,400	1,600	0,000	2,202	4,416	6,652	8,928	11,001	12,740	14,216	15,400	16,916	17,568	17,513
322444	19,600	1,600	0,000	2,198	4,407	6,639	8,907	10,943	12,655	14,114	15,332	16,821	17,490	17,458
326042	19,800	1,600	0,000	2,194	4,399	6,627	8,883	10,884	12,565	14,007	15,244	16,725	17,412	17,372
329644	20,000	1,600	0,000	2,190	4,392	6,616	8,859	10,823	12,483	13,914	15,079	16,628	17,333	17,317
333248	20,200	1,600	0,000	2,187	4,385	6,605	8,833	10,762	12,403	13,808	14,979	16,531	17,254	17,261
336856	20,400	1,600	0,000	2,184	4,378	6,595	8,805	10,701	12,313	13,704	14,884	16,433	17,175	17,205
340466	20,600	1,600	0,000	2,181	4,372	6,586	8,777	10,640	12,227	13,606	14,759	16,335	17,096	17,150
344080	20,800	1,600	0,000	2,178	4,367	6,577	8,746	10,578	12,144	13,510	14,648	16,237	17,016	17,094
347696	21,000	1,600	0,000	2,176	4,362	6,569	8,714	10,515	12,063	13,402	14,547	16,138	16,937	17,038
351315	21,200	1,600	0,000	2,173	4,357	6,562	8,680	10,452	11,975	13,298	14,438	16,038	16,857	16,982
354937	21,400	1,600	0,000	2,171	4,352	6,555	8,645	10,387	11,892	13,217	14,329	15,939	16,777	16,926
358562	21,600	1,600	0,000	2,170	4,348	6,549	8,608	10,321	11,808	13,113	14,221	15,839	16,696	16,870
362189	21,800	1,600	0,000	2,168	4,345	6,543	8,570	10,258	11,727	13,008	14,113	15,738	16,616	16,814
365818	22,000	1,600	0,000	2,166	4,342	6,537	8,531	10,195	11,640	12,911	14,006	15,637	16,535	16,758
369450	22,200	1,600	0,000	2,165	4,339	6,531	8,489	10,127	11,568	12,812	13,898	15,536	16,453	16,701
373085	22,400	1,600	0,000	2,164	4,337	6,522	8,446	10,065	11,476	12,713	13,791	15,435	16,338	16,645
376723	22,600	1,600	0,000	2,163	4,335	6,512	8,401	9,999	11,406	12,615	13,685	15,334	16,257	16,589

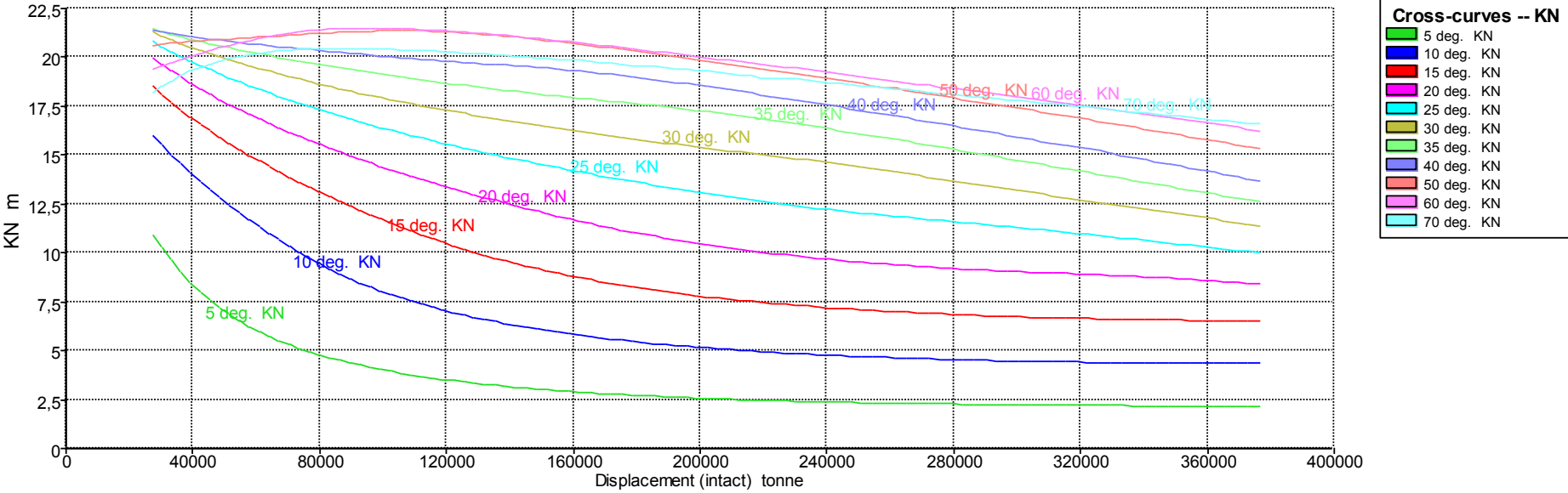

• **Para un trimado de 3,2 m:**

Displacement (intact) tonne	Draft Amidships m	Trim (+ve by stern) m	TCG m	KN 5,0 deg. Starb.	KN 10,0 deg. Starb.	KN 15,0 deg. Starb.	KN 20,0 deg. Starb.	KN 25,0 deg. Starb.	KN 30,0 deg. Starb.	KN 35,0 deg. Starb.	KN 40,0 deg. Starb.	KN 50,0 deg. Starb.	KN 60,0 deg. Starb.	KN 70,0 deg. Starb.
26935	2,000	3,200	0,000	10,634	15,545	18,011	19,502	20,438	20,987	21,233	21,234	20,678	19,622	18,522
29900	2,200	3,200	0,000	10,058	15,124	17,683	19,242	20,236	20,839	21,134	21,183	20,718	19,759	18,746
32888	2,400	3,200	0,000	9,501	14,703	17,353	18,980	20,030	20,686	21,033	21,130	20,758	19,898	18,963
35897	2,600	3,200	0,000	8,971	14,287	17,024	18,717	19,824	20,532	20,930	21,075	20,798	20,036	19,169
38924	2,800	3,200	0,000	8,473	13,881	16,702	18,458	19,620	20,379	20,826	21,019	20,836	20,171	19,360
41969	3,000	3,200	0,000	8,012	13,482	16,384	18,204	19,419	20,227	20,723	20,963	20,872	20,305	19,535
45030	3,200	3,200	0,000	7,587	13,092	16,075	17,953	19,221	20,077	20,621	20,907	20,907	20,435	19,695
48105	3,400	3,200	0,000	7,201	12,713	15,771	17,709	19,027	19,930	20,520	20,852	20,942	20,562	19,835
51193	3,600	3,200	0,000	6,852	12,344	15,474	17,470	18,837	19,786	20,420	20,798	20,974	20,682	19,959
54293	3,800	3,200	0,000	6,537	11,985	15,185	17,236	18,652	19,645	20,322	20,743	21,006	20,796	20,063
57406	4,000	3,200	0,000	6,251	11,635	14,902	17,007	18,470	19,506	20,226	20,690	21,038	20,903	20,152
60531	4,200	3,200	0,000	5,990	11,296	14,626	16,783	18,292	19,371	20,132	20,638	21,068	21,002	20,227
63666	4,400	3,200	0,000	5,752	10,966	14,357	16,564	18,118	19,239	20,039	20,586	21,098	21,092	20,286
66812	4,600	3,200	0,000	5,533	10,647	14,094	16,351	17,948	19,109	19,948	20,535	21,127	21,175	20,336
69968	4,800	3,200	0,000	5,333	10,338	13,837	16,141	17,782	18,982	19,860	20,484	21,154	21,247	20,376
73134	5,000	3,200	0,000	5,147	10,039	13,587	15,937	17,618	18,857	19,773	20,435	21,184	21,309	20,406
76309	5,200	3,200	0,000	4,975	9,752	13,341	15,737	17,458	18,736	19,687	20,387	21,212	21,362	20,429
79491	5,400	3,200	0,000	4,817	9,478	13,102	15,541	17,302	18,616	19,604	20,339	21,239	21,403	20,447
82683	5,600	3,200	0,000	4,669	9,216	12,867	15,350	17,148	18,499	19,522	20,291	21,265	21,436	20,457
85882	5,800	3,200	0,000	4,532	8,967	12,638	15,162	16,998	18,384	19,442	20,246	21,289	21,460	20,462
89090	6,000	3,200	0,000	4,404	8,732	12,413	14,978	16,850	18,271	19,363	20,201	21,311	21,476	20,462
92307	6,200	3,200	0,000	4,285	8,510	12,194	14,798	16,705	18,160	19,285	20,157	21,330	21,484	20,459
95531	6,400	3,200	0,000	4,173	8,301	11,979	14,621	16,564	18,051	19,209	20,113	21,345	21,488	20,449
98762	6,600	3,200	0,000	4,068	8,105	11,769	14,448	16,424	17,945	19,135	20,071	21,355	21,483	20,430
102001	6,800	3,200	0,000	3,970	7,919	11,562	14,278	16,288	17,840	19,062	20,029	21,361	21,474	20,424
105246	7,000	3,200	0,000	3,878	7,743	11,361	14,111	16,154	17,737	18,989	19,988	21,360	21,460	20,405
108499	7,200	3,200	0,000	3,791	7,576	11,165	13,948	16,023	17,636	18,918	19,948	21,356	21,441	20,383
111758	7,400	3,200	0,000	3,710	7,419	10,973	13,787	15,894	17,537	18,849	19,908	21,345	21,420	20,364
115025	7,600	3,200	0,000	3,633	7,270	10,787	13,628	15,767	17,439	18,780	19,870	21,328	21,392	20,332
118298	7,800	3,200	0,000	3,560	7,128	10,605	13,473	15,642	17,344	18,714	19,830	21,307	21,363	20,306
121578	8,000	3,200	0,000	3,492	6,994	10,428	13,320	15,519	17,250	18,648	19,793	21,280	21,335	20,280
124864	8,200	3,200	0,000	3,427	6,867	10,257	13,170	15,398	17,157	18,584	19,757	21,250	21,294	20,249
128158	8,400	3,200	0,000	3,365	6,746	10,093	13,022	15,279	17,066	18,519	19,722	21,217	21,255	20,205

PETROLERO VLCC DE 300.000 TPM

CUADERNO IV: COMPARTIMENTADO Y CÁLCULOS DE ARQUITECTURA NAVAL

PEDRO LEMOS GONZÁLEZ

Displacement (intact) tonne	Draft Amidships m	Trim (+ve by stern) m	TCG m	KN 5,0 deg. Starb.	KN 10,0 deg. Starb.	KN 15,0 deg. Starb.	KN 20,0 deg. Starb.	KN 25,0 deg. Starb.	KN 30,0 deg. Starb.	KN 35,0 deg. Starb.	KN 40,0 deg. Starb.	KN 50,0 deg. Starb.	KN 60,0 deg. Starb.	KN 70,0 deg. Starb.
131456	8,600	3,200	0,000	3,307	6,632	9,935	12,877	15,162	16,977	18,457	19,682	21,176	21,223	20,182
134761	8,800	3,200	0,000	3,252	6,523	9,784	12,735	15,047	16,889	18,395	19,652	21,134	21,171	20,145
138073	9,000	3,200	0,000	3,199	6,419	9,638	12,594	14,934	16,803	18,335	19,616	21,089	21,122	20,111
141390	9,200	3,200	0,000	3,150	6,321	9,499	12,456	14,823	16,717	18,276	19,580	21,041	21,077	20,080
144714	9,400	3,200	0,000	3,102	6,227	9,365	12,321	14,713	16,633	18,216	19,542	20,989	21,026	20,042
148045	9,600	3,200	0,000	3,057	6,138	9,237	12,188	14,605	16,551	18,160	19,502	20,935	20,975	20,006
151382	9,800	3,200	0,000	3,015	6,053	9,115	12,057	14,499	16,469	18,103	19,459	20,878	20,920	19,968
154725	10,000	3,200	0,000	2,974	5,972	8,997	11,929	14,394	16,390	18,049	19,414	20,829	20,865	19,935
158074	10,200	3,200	0,000	2,936	5,895	8,884	11,803	14,291	16,311	17,994	19,365	20,760	20,801	19,882
161430	10,400	3,200	0,000	2,899	5,821	8,776	11,680	14,189	16,233	17,941	19,308	20,696	20,750	19,845
164793	10,600	3,200	0,000	2,864	5,751	8,672	11,560	14,088	16,157	17,889	19,259	20,633	20,688	19,810
168163	10,800	3,200	0,000	2,830	5,684	8,573	11,442	13,990	16,081	17,836	19,203	20,566	20,633	19,766
171541	11,000	3,200	0,000	2,799	5,620	8,478	11,328	13,892	16,007	17,785	19,144	20,495	20,569	19,716
174924	11,200	3,200	0,000	2,768	5,559	8,386	11,217	13,796	15,934	17,732	19,081	20,427	20,510	19,678
178315	11,400	3,200	0,000	2,739	5,500	8,299	11,109	13,701	15,862	17,678	19,017	20,358	20,450	19,629
181713	11,600	3,200	0,000	2,711	5,444	8,215	11,005	13,607	15,791	17,622	18,950	20,282	20,394	19,596
185118	11,800	3,200	0,000	2,685	5,390	8,134	10,904	13,515	15,720	17,564	18,882	20,209	20,326	19,536
188531	12,000	3,200	0,000	2,659	5,339	8,057	10,807	13,424	15,651	17,504	18,812	20,134	20,263	19,488
191950	12,200	3,200	0,000	2,635	5,290	7,983	10,713	13,334	15,583	17,441	18,739	20,059	20,194	19,449
195375	12,400	3,200	0,000	2,612	5,243	7,913	10,623	13,246	15,515	17,376	18,665	19,977	20,137	19,390
198808	12,600	3,200	0,000	2,590	5,199	7,845	10,535	13,160	15,449	17,309	18,590	19,906	20,072	19,334
202248	12,800	3,200	0,000	2,569	5,156	7,780	10,451	13,074	15,383	17,240	18,513	19,823	20,007	19,286
205694	13,000	3,200	0,000	2,548	5,115	7,718	10,369	12,990	15,318	17,169	18,433	19,741	19,937	19,221
209147	13,200	3,200	0,000	2,529	5,075	7,658	10,291	12,908	15,254	17,095	18,352	19,660	19,871	19,243
212608	13,400	3,200	0,000	2,510	5,037	7,601	10,215	12,827	15,190	17,020	18,270	19,584	19,786	19,128
216075	13,600	3,200	0,000	2,493	5,001	7,546	10,143	12,747	15,125	16,944	18,188	19,504	19,733	19,069
219549	13,800	3,200	0,000	2,476	4,967	7,493	10,072	12,669	15,059	16,866	18,108	19,432	19,660	19,020
223030	14,000	3,200	0,000	2,459	4,933	7,442	10,005	12,594	14,991	16,786	18,018	19,343	19,580	18,985
226517	14,200	3,200	0,000	2,444	4,902	7,394	9,940	12,520	14,922	16,704	17,931	19,261	19,533	18,914
230010	14,400	3,200	0,000	2,429	4,871	7,348	9,878	12,449	14,852	16,622	17,842	19,177	19,451	19,041
233510	14,600	3,200	0,000	2,414	4,842	7,303	9,818	12,380	14,780	16,539	17,756	19,101	19,393	18,823
237016	14,800	3,200	0,000	2,400	4,814	7,261	9,761	12,312	14,706	16,452	17,673	19,013	19,311	18,765
240528	15,000	3,200	0,000	2,387	4,787	7,220	9,706	12,247	14,630	16,365	17,577	18,933	19,232	18,692
244045	15,200	3,200	0,000	2,374	4,762	7,181	9,653	12,185	14,554	16,278	17,475	18,852	19,168	18,660
247569	15,400	3,200	0,000	2,362	4,737	7,144	9,602	12,124	14,475	16,188	17,395	18,770	19,093	18,591
251098	15,600	3,200	0,000	2,351	4,714	7,107	9,554	12,065	14,396	16,098	17,294	18,684	19,028	18,608
254632	15,800	3,200	0,000	2,339	4,691	7,073	9,507	12,008	14,315	16,006	17,201	18,592	18,934	18,499
258171	16,000	3,200	0,000	2,329	4,670	7,041	9,462	11,953	14,233	15,915	17,107	18,551	18,884	18,445
261715	16,200	3,200	0,000	2,319	4,650	7,009	9,420	11,898	14,149	15,817	17,010	18,397	18,803	18,392
265264	16,400	3,200	0,000	2,309	4,630	6,979	9,378	11,845	14,065	15,728	16,930	18,329	18,713	18,338

PETROLERO VLCC DE 300.000 TPM

CUADERNO IV: COMPARTIMENTADO Y CÁLCULOS DE ARQUITECTURA NAVAL

PEDRO LEMOS GONZÁLEZ

Displacement (intact) tonne	Draft Amidships m	Trim (+ve by stern) m	TCG m	KN 5,0 deg. Starb.	KN 10,0 deg. Starb.	KN 15,0 deg. Starb.	KN 20,0 deg. Starb.	KN 25,0 deg. Starb.	KN 30,0 deg. Starb.	KN 35,0 deg. Starb.	KN 40,0 deg. Starb.	KN 50,0 deg. Starb.	KN 60,0 deg. Starb.	KN 70,0 deg. Starb.
268817	16,600	3,200	0,000	2,299	4,611	6,951	9,339	11,792	13,980	15,630	16,824	18,259	18,643	18,284
272374	16,800	3,200	0,000	2,290	4,593	6,923	9,302	11,739	13,895	15,534	16,716	18,143	18,577	18,230
275935	17,000	3,200	0,000	2,282	4,576	6,897	9,266	11,686	13,807	15,436	16,629	18,051	18,496	18,176
279500	17,200	3,200	0,000	2,274	4,560	6,872	9,232	11,632	13,720	15,338	16,527	17,960	18,410	18,123
283069	17,400	3,200	0,000	2,266	4,544	6,848	9,199	11,578	13,634	15,241	16,450	17,867	18,346	18,069
286642	17,600	3,200	0,000	2,259	4,529	6,826	9,168	11,524	13,546	15,140	16,330	17,772	18,271	18,015
290218	17,800	3,200	0,000	2,252	4,515	6,804	9,138	11,469	13,457	15,050	16,232	17,674	18,194	17,961
293797	18,000	3,200	0,000	2,245	4,502	6,783	9,110	11,414	13,371	14,941	16,130	17,580	18,118	17,907
297380	18,200	3,200	0,000	2,238	4,489	6,764	9,083	11,358	13,281	14,841	16,028	17,556	18,042	17,853
300966	18,400	3,200	0,000	2,232	4,477	6,745	9,058	11,301	13,196	14,741	15,924	17,395	17,965	17,799
304555	18,600	3,200	0,000	2,227	4,465	6,728	9,033	11,244	13,108	14,640	15,825	17,300	17,888	17,744
308148	18,800	3,200	0,000	2,221	4,454	6,711	9,010	11,187	13,018	14,538	15,726	17,214	17,811	17,689
311743	19,000	3,200	0,000	2,216	4,444	6,695	8,986	11,129	12,930	14,436	15,618	17,093	17,734	17,635
315342	19,200	3,200	0,000	2,211	4,434	6,680	8,963	11,071	12,841	14,334	15,518	17,009	17,657	17,580
318944	19,400	3,200	0,000	2,207	4,424	6,666	8,940	11,011	12,755	14,233	15,416	16,931	17,579	17,525
322548	19,600	3,200	0,000	2,202	4,416	6,652	8,916	10,952	12,669	14,124	15,304	16,820	17,500	17,469
326156	19,800	3,200	0,000	2,198	4,407	6,640	8,891	10,892	12,582	14,017	15,201	16,774	17,422	17,414
329766	20,000	3,200	0,000	2,194	4,400	6,628	8,865	10,831	12,496	13,925	15,124	16,635	17,343	17,359
333379	20,200	3,200	0,000	2,191	4,392	6,617	8,838	10,770	12,410	13,821	14,984	16,537	17,264	17,303
336995	20,400	3,200	0,000	2,188	4,386	6,606	8,809	10,708	12,324	13,734	14,874	16,440	17,184	17,248
340614	20,600	3,200	0,000	2,184	4,379	6,597	8,779	10,645	12,236	13,620	14,767	16,343	17,106	17,163
344235	20,800	3,200	0,000	2,182	4,373	6,588	8,748	10,583	12,153	13,520	14,654	16,244	17,026	17,107
347859	21,000	3,200	0,000	2,179	4,368	6,579	8,715	10,519	12,072	13,418	14,546	16,144	16,946	17,051
351485	21,200	3,200	0,000	2,177	4,363	6,572	8,680	10,455	11,983	13,324	14,441	16,044	16,866	16,995
355113	21,400	3,200	0,000	2,174	4,358	6,564	8,644	10,391	11,909	13,214	14,320	15,945	16,785	16,939
358744	21,600	3,200	0,000	2,172	4,354	6,557	8,606	10,325	11,821	13,114	14,220	15,844	16,704	16,883
362376	21,800	3,200	0,000	2,171	4,350	6,549	8,567	10,261	11,730	13,013	14,129	15,744	16,623	16,826
366011	22,000	3,200	0,000	2,169	4,347	6,540	8,527	10,195	11,647	12,923	14,008	15,643	16,542	16,769
369647	22,200	3,200	0,000	2,168	4,344	6,530	8,485	10,128	11,565	12,818	13,900	15,542	16,461	16,713
373285	22,400	3,200	0,000	2,166	4,342	6,519	8,441	10,062	11,477	12,749	13,793	15,440	16,379	16,656
376925	22,600	3,200	0,000	2,165	4,339	6,506	8,395	9,995	11,391	12,621	13,685	15,339	16,297	16,599

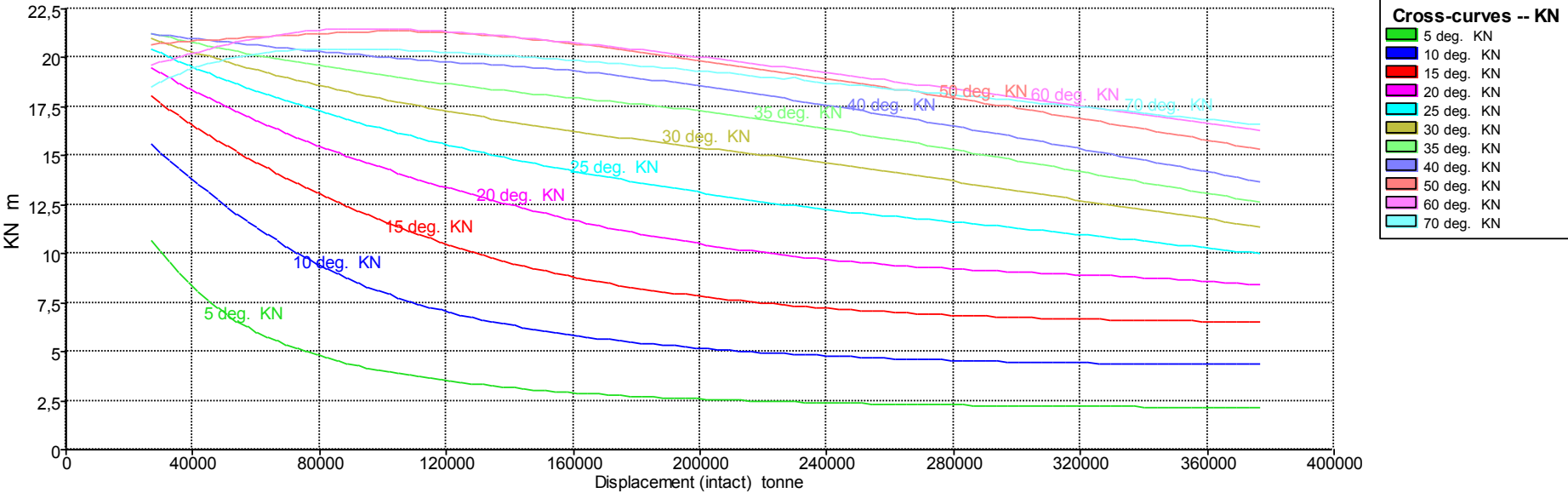

• Para un trimado de 4.8 m:

Displacement (intact) tonne	Draft Amidships m	Trim (+ve by stern) m	TCG m	KN 5,0 deg. Starb.	KN 10,0 deg. Starb.	KN 15,0 deg. Starb.	KN 20,0 deg. Starb.	KN 25,0 deg. Starb.	KN 30,0 deg. Starb.	KN 35,0 deg. Starb.	KN 40,0 deg. Starb.	KN 50,0 deg. Starb.	KN 60,0 deg. Starb.	KN 70,0 deg. Starb.
26663	2,000	4,800	0,000	10,022	14,788	17,263	18,812	19,833	20,497	20,879	21,017	20,731	19,948	18,971
29568	2,200	4,800	0,000	9,608	14,505	17,060	18,662	19,726	20,422	20,833	21,000	20,767	20,039	19,092
32516	2,400	4,800	0,000	9,184	14,195	16,831	18,490	19,598	20,331	20,775	20,974	20,801	20,140	19,224
35493	2,600	4,800	0,000	8,758	13,870	16,586	18,301	19,455	20,227	20,706	20,941	20,835	20,246	19,360
38493	2,800	4,800	0,000	8,342	13,536	16,331	18,103	19,303	20,115	20,631	20,903	20,870	20,354	19,496
41514	3,000	4,800	0,000	7,941	13,199	16,069	17,898	19,144	19,997	20,552	20,862	20,904	20,460	19,627
44552	3,200	4,800	0,000	7,560	12,861	15,806	17,690	18,983	19,876	20,470	20,819	20,937	20,566	19,751
47607	3,400	4,800	0,000	7,201	12,523	15,543	17,480	18,818	19,754	20,387	20,774	20,970	20,668	19,866
50678	3,600	4,800	0,000	6,867	12,190	15,279	17,271	18,655	19,631	20,302	20,728	21,001	20,767	19,972
53764	3,800	4,800	0,000	6,557	11,863	15,020	17,064	18,492	19,509	20,218	20,682	21,032	20,861	20,066
56863	4,000	4,800	0,000	6,274	11,541	14,764	16,859	18,331	19,386	20,133	20,635	21,062	20,949	20,149
59974	4,200	4,800	0,000	6,015	11,224	14,510	16,657	18,170	19,265	20,049	20,588	21,092	21,031	20,220
63097	4,400	4,800	0,000	5,778	10,915	14,261	16,456	18,012	19,145	19,966	20,541	21,121	21,107	20,280
66230	4,600	4,800	0,000	5,560	10,614	14,015	16,259	17,856	19,027	19,884	20,495	21,149	21,177	20,332
69375	4,800	4,800	0,000	5,359	10,322	13,773	16,064	17,702	18,910	19,803	20,449	21,177	21,240	20,370
72530	5,000	4,800	0,000	5,174	10,038	13,536	15,873	17,550	18,795	19,723	20,403	21,202	21,296	20,402
75696	5,200	4,800	0,000	5,002	9,764	13,302	15,684	17,401	18,682	19,644	20,358	21,229	21,343	20,426
78872	5,400	4,800	0,000	4,843	9,500	13,073	15,498	17,254	18,570	19,566	20,314	21,252	21,382	20,443
82058	5,600	4,800	0,000	4,695	9,246	12,848	15,316	17,109	18,460	19,490	20,271	21,274	21,415	20,455
85253	5,800	4,800	0,000	4,558	9,004	12,627	15,136	16,966	18,352	19,414	20,228	21,293	21,439	20,461
88457	6,000	4,800	0,000	4,429	8,772	12,410	14,960	16,825	18,245	19,340	20,185	21,309	21,456	20,462
91669	6,200	4,800	0,000	4,310	8,552	12,198	14,787	16,687	18,139	19,267	20,143	21,322	21,466	20,457
94889	6,400	4,800	0,000	4,198	8,344	11,989	14,616	16,550	18,036	19,194	20,103	21,331	21,471	20,448
98117	6,600	4,800	0,000	4,093	8,147	11,785	14,448	16,416	17,933	19,124	20,062	21,337	21,468	20,439
101353	6,800	4,800	0,000	3,995	7,961	11,585	14,283	16,284	17,833	19,053	20,023	21,339	21,460	20,423
104596	7,000	4,800	0,000	3,902	7,785	11,388	14,120	16,155	17,734	18,984	19,984	21,337	21,449	20,406
107848	7,200	4,800	0,000	3,815	7,619	11,195	13,960	16,027	17,636	18,916	19,945	21,331	21,430	20,384
111107	7,400	4,800	0,000	3,733	7,461	11,008	13,804	15,902	17,540	18,849	19,906	21,321	21,409	20,381
114374	7,600	4,800	0,000	3,656	7,311	10,825	13,649	15,778	17,445	18,783	19,871	21,305	21,384	20,336
117649	7,800	4,800	0,000	3,583	7,170	10,646	13,496	15,656	17,352	18,718	19,835	21,284	21,362	20,310
120931	8,000	4,800	0,000	3,514	7,035	10,473	13,346	15,536	17,260	18,654	19,799	21,259	21,324	20,275

PETROLERO VLCC DE 300.000 TPM

CUADERNO IV: COMPARTIMENTADO Y CÁLCULOS DE ARQUITECTURA NAVAL

PEDRO LEMOS GONZÁLEZ

Displacement (intact) tonne	Draft Amidships m	Trim (+ve by stern) m	TCG m	KN 5,0 deg. Starb.	KN 10,0 deg. Starb.	KN 15,0 deg. Starb.	KN 20,0 deg. Starb.	KN 25,0 deg. Starb.	KN 30,0 deg. Starb.	KN 35,0 deg. Starb.	KN 40,0 deg. Starb.	KN 50,0 deg. Starb.	KN 60,0 deg. Starb.	KN 70,0 deg. Starb.
124221	8,200	4,800	0,000	3,449	6,908	10,305	13,198	15,418	17,170	18,591	19,763	21,231	21,288	20,253
127518	8,400	4,800	0,000	3,387	6,786	10,142	13,053	15,301	17,081	18,529	19,728	21,198	21,250	20,225
130823	8,600	4,800	0,000	3,328	6,671	9,984	12,910	15,186	16,993	18,469	19,693	21,161	21,209	20,190
134136	8,800	4,800	0,000	3,272	6,562	9,833	12,769	15,073	16,907	18,409	19,657	21,120	21,166	20,144
137456	9,000	4,800	0,000	3,220	6,458	9,687	12,630	14,961	16,822	18,349	19,619	21,076	21,118	20,120
140783	9,200	4,800	0,000	3,170	6,359	9,547	12,494	14,851	16,738	18,291	19,582	21,030	21,074	20,090
144115	9,400	4,800	0,000	3,122	6,264	9,413	12,360	14,743	16,656	18,234	19,542	20,981	21,023	20,054
147455	9,600	4,800	0,000	3,077	6,175	9,285	12,228	14,636	16,574	18,177	19,501	20,929	20,972	20,018
150802	9,800	4,800	0,000	3,034	6,089	9,161	12,098	14,530	16,494	18,122	19,458	20,875	20,917	19,981
154157	10,000	4,800	0,000	2,993	6,007	9,043	11,971	14,426	16,415	18,068	19,413	20,817	20,864	19,937
157520	10,200	4,800	0,000	2,954	5,930	8,929	11,846	14,323	16,337	18,015	19,365	20,755	20,809	19,899
160890	10,400	4,800	0,000	2,917	5,855	8,820	11,724	14,223	16,259	17,962	19,315	20,696	20,751	19,899
164267	10,600	4,800	0,000	2,882	5,784	8,716	11,604	14,123	16,184	17,909	19,261	20,632	20,703	19,819
167653	10,800	4,800	0,000	2,848	5,716	8,616	11,487	14,024	16,109	17,856	19,206	20,567	20,642	19,776
171046	11,000	4,800	0,000	2,815	5,651	8,520	11,373	13,927	16,035	17,802	19,141	20,498	20,580	19,730
174447	11,200	4,800	0,000	2,785	5,589	8,427	11,262	13,831	15,963	17,747	19,086	20,449	20,522	19,689
177855	11,400	4,800	0,000	2,755	5,530	8,339	11,154	13,737	15,891	17,692	19,024	20,359	20,458	19,638
181271	11,600	4,800	0,000	2,727	5,474	8,254	11,049	13,643	15,820	17,634	18,956	20,287	20,399	19,588
184694	11,800	4,800	0,000	2,700	5,419	8,173	10,948	13,551	15,750	17,575	18,889	20,212	20,338	19,548
188124	12,000	4,800	0,000	2,675	5,367	8,095	10,850	13,460	15,681	17,515	18,818	20,137	20,273	19,496
191561	12,200	4,800	0,000	2,650	5,318	8,021	10,755	13,371	15,612	17,452	18,747	20,062	20,221	19,443
195006	12,400	4,800	0,000	2,626	5,270	7,949	10,664	13,283	15,545	17,387	18,673	19,984	20,146	19,377
198457	12,600	4,800	0,000	2,604	5,225	7,881	10,576	13,196	15,478	17,320	18,598	19,906	20,077	19,368
201917	12,800	4,800	0,000	2,582	5,181	7,815	10,491	13,111	15,412	17,251	18,521	19,835	20,013	19,298
205383	13,000	4,800	0,000	2,562	5,139	7,752	10,408	13,027	15,346	17,180	18,443	19,755	19,948	19,230
208857	13,200	4,800	0,000	2,542	5,099	7,691	10,329	12,944	15,280	17,108	18,363	19,677	19,880	19,187
212337	13,400	4,800	0,000	2,523	5,061	7,633	10,253	12,863	15,214	17,033	18,281	19,594	19,812	19,212
215824	13,600	4,800	0,000	2,505	5,024	7,577	10,180	12,784	15,147	16,957	18,198	19,520	19,744	19,084
219317	13,800	4,800	0,000	2,487	4,989	7,524	10,109	12,706	15,079	16,878	18,113	19,438	19,679	19,038
222817	14,000	4,800	0,000	2,471	4,955	7,473	10,041	12,630	15,011	16,799	18,028	19,376	19,605	18,981
226324	14,200	4,800	0,000	2,454	4,922	7,424	9,975	12,556	14,940	16,717	17,943	19,269	19,534	18,945
229836	14,400	4,800	0,000	2,439	4,892	7,377	9,912	12,485	14,869	16,635	17,852	19,191	19,464	18,880
233354	14,600	4,800	0,000	2,424	4,862	7,332	9,852	12,415	14,796	16,551	17,765	19,106	19,393	18,833
236878	14,800	4,800	0,000	2,410	4,833	7,288	9,794	12,347	14,722	16,465	17,675	19,029	19,316	18,771
240407	15,000	4,800	0,000	2,397	4,806	7,247	9,738	12,282	14,646	16,377	17,585	18,938	19,239	18,734
243941	15,200	4,800	0,000	2,384	4,780	7,207	9,685	12,219	14,569	16,291	17,493	18,857	19,154	18,673
247480	15,400	4,800	0,000	2,371	4,755	7,169	9,633	12,157	14,490	16,200	17,398	18,775	19,109	18,590
251024	15,600	4,800	0,000	2,359	4,731	7,133	9,584	12,097	14,410	16,110	17,306	18,686	19,030	18,560
254573	15,800	4,800	0,000	2,348	4,708	7,098	9,537	12,038	14,329	16,018	17,209	18,615	18,948	18,506
258126	16,000	4,800	0,000	2,337	4,687	7,065	9,492	11,981	14,246	15,925	17,136	18,512	18,837	18,442

PETROLERO VLCC DE 300.000 TPM

CUADERNO IV: COMPARTIMENTADO Y CÁLCULOS DE ARQUITECTURA NAVAL

PEDRO LEMOS GONZÁLEZ

Displacement (intact) tonne	Draft Amidships m	Trim (+ve by stern) m	TCG m	KN 5,0 deg. Starb.	KN 10,0 deg. Starb.	KN 15,0 deg. Starb.	KN 20,0 deg. Starb.	KN 25,0 deg. Starb.	KN 30,0 deg. Starb.	KN 35,0 deg. Starb.	KN 40,0 deg. Starb.	KN 50,0 deg. Starb.	KN 60,0 deg. Starb.	KN 70,0 deg. Starb.
261684	16,200	4,800	0,000	2,326	4,666	7,033	9,448	11,924	14,162	15,830	17,047	18,427	18,803	18,389
265245	16,400	4,800	0,000	2,316	4,645	7,002	9,407	11,868	14,078	15,736	16,931	18,335	18,724	18,336
268810	16,600	4,800	0,000	2,307	4,626	6,973	9,367	11,812	13,993	15,640	16,833	18,237	18,649	18,290
272379	16,800	4,800	0,000	2,298	4,608	6,945	9,329	11,757	13,906	15,544	16,731	18,150	18,563	18,236
275952	17,000	4,800	0,000	2,289	4,590	6,918	9,293	11,702	13,819	15,446	16,631	18,059	18,502	18,182
279528	17,200	4,800	0,000	2,280	4,574	6,893	9,258	11,646	13,731	15,348	16,542	17,961	18,427	18,128
283108	17,400	4,800	0,000	2,273	4,558	6,868	9,225	11,591	13,644	15,249	16,444	17,887	18,350	18,074
286691	17,600	4,800	0,000	2,265	4,542	6,845	9,193	11,535	13,556	15,156	16,330	17,784	18,273	18,020
290277	17,800	4,800	0,000	2,258	4,528	6,823	9,163	11,480	13,468	15,054	16,243	17,687	18,194	17,966
293866	18,000	4,800	0,000	2,251	4,514	6,802	9,134	11,423	13,379	14,950	16,143	17,599	18,134	17,911
297459	18,200	4,800	0,000	2,244	4,501	6,782	9,107	11,366	13,291	14,852	16,047	17,492	18,039	17,857
301054	18,400	4,800	0,000	2,238	4,488	6,763	9,080	11,309	13,202	14,746	15,940	17,406	17,968	17,803
304653	18,600	4,800	0,000	2,232	4,476	6,745	9,053	11,251	13,113	14,650	15,837	17,301	17,891	17,749
308254	18,800	4,800	0,000	2,226	4,465	6,727	9,027	11,193	13,026	14,546	15,734	17,208	17,814	17,695
311859	19,000	4,800	0,000	2,221	4,454	6,711	9,001	11,134	12,936	14,445	15,630	17,117	17,736	17,640
315466	19,200	4,800	0,000	2,216	4,444	6,696	8,975	11,074	12,848	14,344	15,534	17,014	17,658	17,585
319076	19,400	4,800	0,000	2,211	4,434	6,681	8,949	11,014	12,761	14,240	15,417	16,930	17,580	17,530
322689	19,600	4,800	0,000	2,207	4,425	6,667	8,922	10,955	12,674	14,141	15,302	16,801	17,502	17,475
326305	19,800	4,800	0,000	2,203	4,417	6,654	8,895	10,893	12,587	14,033	15,165	16,783	17,424	17,420
329924	20,000	4,800	0,000	2,199	4,409	6,642	8,866	10,832	12,500	13,935	15,061	16,634	17,345	17,365
333545	20,200	4,800	0,000	2,195	4,401	6,630	8,837	10,769	12,414	13,830	14,984	16,545	17,266	17,309
337169	20,400	4,800	0,000	2,192	4,394	6,620	8,807	10,707	12,327	13,728	14,864	16,423	17,187	17,253
340794	20,600	4,800	0,000	2,189	4,387	6,609	8,775	10,643	12,239	13,621	14,775	16,334	17,107	17,198
344422	20,800	4,800	0,000	2,186	4,381	6,600	8,742	10,579	12,155	13,523	14,659	16,238	17,027	17,142
348052	21,000	4,800	0,000	2,183	4,376	6,591	8,708	10,516	12,070	13,423	14,566	16,139	16,947	17,086
351684	21,200	4,800	0,000	2,180	4,370	6,581	8,672	10,450	11,987	13,313	14,466	16,040	16,866	17,030
355318	21,400	4,800	0,000	2,178	4,366	6,572	8,635	10,385	11,899	13,212	14,326	15,941	16,785	16,974
358953	21,600	4,800	0,000	2,176	4,361	6,561	8,596	10,321	11,812	13,111	14,204	15,840	16,704	16,889
362590	21,800	4,800	0,000	2,174	4,357	6,550	8,556	10,254	11,729	13,001	14,154	15,739	16,623	16,832
366228	22,000	4,800	0,000	2,172	4,354	6,539	8,514	10,188	11,641	12,909	13,959	15,638	16,542	16,775
369868	22,200	4,800	0,000	2,171	4,351	6,526	8,471	10,121	11,557	12,806	13,872	15,536	16,460	16,718
373510	22,400	4,800	0,000	2,169	4,348	6,511	8,425	10,052	11,470	12,707	13,802	15,434	16,378	16,661
377153	22,600	4,800	0,000	2,168	4,346	6,496	8,379	9,984	11,384	12,603	13,676	15,332	16,296	16,603

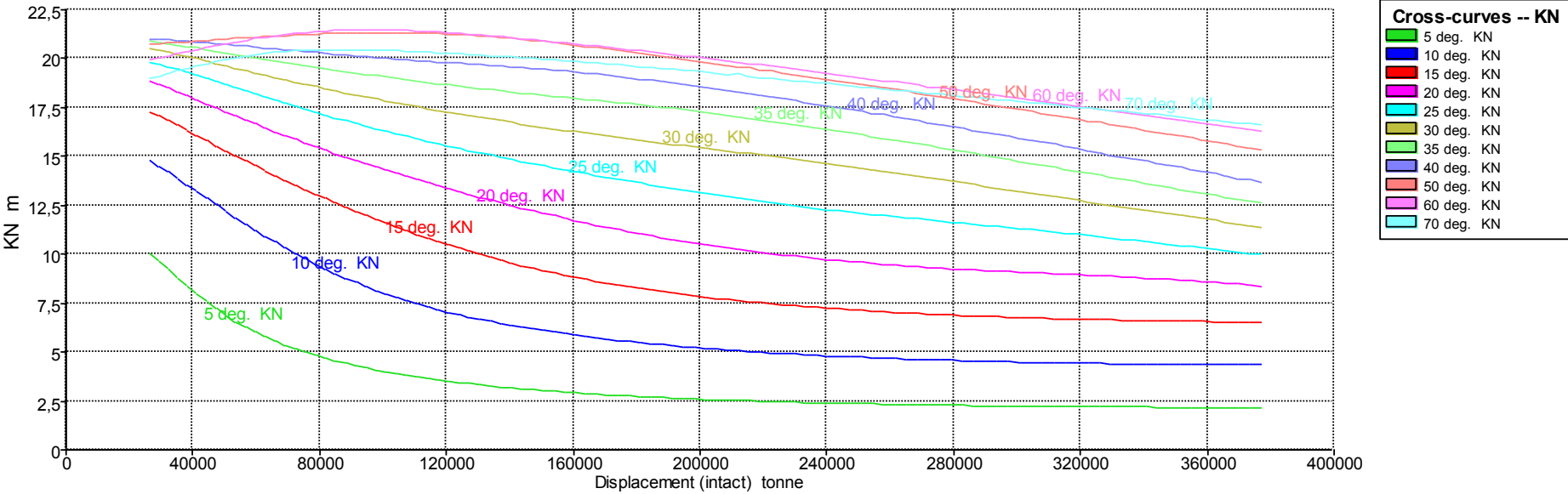

• **Para un trimado de -1,6 m:**

Displacement (intact) tonne	Draft Amidships m	Trim (+ve by stern) m	TCG m	KN 5,0 deg. Starb.	KN 10,0 deg. Starb.	KN 15,0 deg. Starb.	KN 20,0 deg. Starb.	KN 25,0 deg. Starb.	KN 30,0 deg. Starb.	KN 35,0 deg. Starb.	KN 40,0 deg. Starb.	KN 50,0 deg. Starb.	KN 60,0 deg. Starb.	KN 70,0 deg. Starb.
28832	2,000	-1,600	0,000	10,658	15,970	18,516	19,966	20,809	21,249	21,388	21,286	20,533	19,314	18,130
31841	2,200	-1,600	0,000	9,972	15,425	18,085	19,623	20,542	21,051	21,254	21,215	20,584	19,492	18,449
34870	2,400	-1,600	0,000	9,339	14,905	17,669	19,293	20,285	20,860	21,124	21,145	20,633	19,663	18,743
37917	2,600	-1,600	0,000	8,761	14,410	17,271	18,976	20,038	20,675	21,000	21,078	20,679	19,828	19,007
40980	2,800	-1,600	0,000	8,238	13,937	16,888	18,669	19,798	20,496	20,879	21,013	20,723	19,985	19,239
44056	3,000	-1,600	0,000	7,771	13,486	16,520	18,373	19,566	20,323	20,761	20,949	20,766	20,138	19,442
47145	3,200	-1,600	0,000	7,356	13,053	16,165	18,086	19,342	20,156	20,647	20,887	20,806	20,290	19,614
50247	3,400	-1,600	0,000	6,985	12,638	15,824	17,809	19,124	19,994	20,537	20,827	20,846	20,427	19,758
53360	3,600	-1,600	0,000	6,651	12,240	15,494	17,540	18,912	19,836	20,430	20,768	20,884	20,565	19,879
56483	3,800	-1,600	0,000	6,349	11,857	15,176	17,280	18,707	19,682	20,325	20,710	20,922	20,697	19,983
59617	4,000	-1,600	0,000	6,076	11,488	14,868	17,028	18,507	19,532	20,223	20,654	20,957	20,825	20,074
62761	4,200	-1,600	0,000	5,827	11,133	14,571	16,783	18,312	19,386	20,123	20,600	20,992	20,938	20,145
65914	4,400	-1,600	0,000	5,599	10,790	14,282	16,546	18,123	19,244	20,026	20,546	21,026	21,039	20,204
69076	4,600	-1,600	0,000	5,389	10,461	14,003	16,316	17,939	19,104	19,930	20,494	21,058	21,127	20,254
72246	4,800	-1,600	0,000	5,197	10,145	13,731	16,092	17,759	18,968	19,837	20,444	21,090	21,200	20,288
75424	5,000	-1,600	0,000	5,019	9,842	13,467	15,874	17,583	18,835	19,746	20,393	21,123	21,260	20,314
78610	5,200	-1,600	0,000	4,854	9,553	13,211	15,661	17,413	18,705	19,656	20,344	21,153	21,311	20,343
81804	5,400	-1,600	0,000	4,701	9,278	12,961	15,455	17,247	18,577	19,568	20,297	21,183	21,337	20,363
85005	5,600	-1,600	0,000	4,559	9,020	12,718	15,253	17,085	18,453	19,483	20,249	21,213	21,380	20,370
88213	5,800	-1,600	0,000	4,427	8,777	12,482	15,056	16,926	18,331	19,399	20,203	21,239	21,401	20,376
91427	6,000	-1,600	0,000	4,303	8,548	12,251	14,864	16,771	18,213	19,317	20,157	21,268	21,414	20,438
94647	6,200	-1,600	0,000	4,188	8,333	12,026	14,677	16,620	18,097	19,237	20,112	21,290	21,412	20,376
97872	6,400	-1,600	0,000	4,080	8,130	11,807	14,493	16,472	17,983	19,156	20,065	21,307	21,421	20,368
101103	6,600	-1,600	0,000	3,979	7,938	11,593	14,314	16,327	17,872	19,078	20,026	21,317	21,414	20,355
104339	6,800	-1,600	0,000	3,885	7,758	11,385	14,139	16,185	17,763	19,003	19,984	21,321	21,422	20,333
107581	7,000	-1,600	0,000	3,796	7,587	11,182	13,968	16,046	17,657	18,928	19,942	21,319	21,391	20,316
110828	7,200	-1,600	0,000	3,712	7,425	10,984	13,800	15,911	17,552	18,855	19,901	21,311	21,386	20,290
114081	7,400	-1,600	0,000	3,633	7,272	10,792	13,636	15,778	17,450	18,783	19,861	21,295	21,348	20,254
117339	7,600	-1,600	0,000	3,558	7,128	10,606	13,475	15,647	17,349	18,714	19,821	21,275	21,365	20,226

PETROLERO VLCC DE 300.000 TPM

CUADERNO IV: COMPARTIMENTADO Y CÁLCULOS DE ARQUITECTURA NAVAL

PEDRO LEMOS GONZÁLEZ

Displacement (intact) tonne	Draft Amidships m	Trim (+ve by stern) m	TCG m	KN 5,0 deg. Starb.	KN 10,0 deg. Starb.	KN 15,0 deg. Starb.	KN 20,0 deg. Starb.	KN 25,0 deg. Starb.	KN 30,0 deg. Starb.	KN 35,0 deg. Starb.	KN 40,0 deg. Starb.	KN 50,0 deg. Starb.	KN 60,0 deg. Starb.	KN 70,0 deg. Starb.
120602	7,800	-1,600	0,000	3,488	6,990	10,425	13,318	15,519	17,251	18,645	19,783	21,254	21,295	20,229
123870	8,000	-1,600	0,000	3,422	6,860	10,250	13,163	15,394	17,155	18,579	19,745	21,234	21,253	20,196
127143	8,200	-1,600	0,000	3,359	6,737	10,082	13,011	15,271	17,060	18,512	19,708	21,192	21,226	20,219
130420	8,400	-1,600	0,000	3,300	6,619	9,921	12,863	15,150	16,967	18,447	19,672	21,156	21,190	20,168
133702	8,600	-1,600	0,000	3,243	6,508	9,767	12,717	15,032	16,876	18,384	19,636	21,116	21,140	20,105
136988	8,800	-1,600	0,000	3,190	6,403	9,620	12,574	14,915	16,787	18,322	19,601	21,070	21,089	20,061
140278	9,000	-1,600	0,000	3,139	6,303	9,478	12,433	14,801	16,699	18,261	19,565	21,023	21,047	20,029
143573	9,200	-1,600	0,000	3,091	6,207	9,343	12,296	14,689	16,613	18,201	19,524	20,973	21,002	19,994
146873	9,400	-1,600	0,000	3,045	6,117	9,213	12,161	14,578	16,528	18,142	19,483	20,914	20,953	19,953
150177	9,600	-1,600	0,000	3,002	6,030	9,089	12,029	14,470	16,445	18,084	19,439	20,864	20,901	19,901
153486	9,800	-1,600	0,000	2,961	5,948	8,969	11,899	14,363	16,363	18,027	19,393	20,806	20,842	19,879
156800	10,000	-1,600	0,000	2,921	5,870	8,855	11,772	14,258	16,283	17,972	19,344	20,782	20,781	19,840
160118	10,200	-1,600	0,000	2,884	5,795	8,746	11,648	14,155	16,203	17,917	19,292	20,690	20,732	19,817
163441	10,400	-1,600	0,000	2,848	5,724	8,641	11,527	14,053	16,126	17,863	19,238	20,620	20,676	19,761
166769	10,600	-1,600	0,000	2,815	5,657	8,541	11,409	13,953	16,049	17,810	19,181	20,554	20,615	19,719
170101	10,800	-1,600	0,000	2,782	5,592	8,445	11,293	13,855	15,974	17,756	19,123	20,487	20,561	19,652
173439	11,000	-1,600	0,000	2,752	5,530	8,353	11,182	13,758	15,900	17,701	19,059	20,418	20,494	19,629
176782	11,200	-1,600	0,000	2,722	5,471	8,265	11,074	13,663	15,826	17,646	18,996	20,346	20,426	19,570
180129	11,400	-1,600	0,000	2,695	5,415	8,180	10,970	13,569	15,755	17,588	18,929	20,280	20,362	19,581
183481	11,600	-1,600	0,000	2,668	5,362	8,100	10,869	13,476	15,684	17,530	18,862	20,225	20,307	19,515
186839	11,800	-1,600	0,000	2,643	5,310	8,022	10,772	13,386	15,615	17,470	18,790	20,152	20,249	19,449
190201	12,000	-1,600	0,000	2,618	5,261	7,948	10,678	13,296	15,546	17,407	18,718	20,056	20,186	19,412
193569	12,200	-1,600	0,000	2,595	5,214	7,877	10,587	13,208	15,479	17,343	18,646	19,976	20,134	19,378
196942	12,400	-1,600	0,000	2,573	5,170	7,810	10,499	13,122	15,412	17,277	18,572	19,895	20,056	19,354
200321	12,600	-1,600	0,000	2,552	5,127	7,745	10,415	13,037	15,346	17,209	18,493	19,829	19,990	19,275
203706	12,800	-1,600	0,000	2,532	5,086	7,682	10,334	12,954	15,282	17,138	18,417	19,885	19,923	19,236
207096	13,000	-1,600	0,000	2,513	5,047	7,623	10,255	12,872	15,217	17,067	18,339	19,658	19,863	19,176
210494	13,200	-1,600	0,000	2,494	5,009	7,566	10,180	12,792	15,153	16,996	18,256	19,582	19,811	19,126
213897	13,400	-1,600	0,000	2,477	4,973	7,511	10,107	12,713	15,089	16,921	18,163	19,507	19,729	19,067
217306	13,600	-1,600	0,000	2,460	4,939	7,459	10,037	12,636	15,022	16,843	18,090	19,418	19,646	19,024
220722	13,800	-1,600	0,000	2,444	4,906	7,408	9,970	12,561	14,956	16,767	18,008	19,337	19,551	18,954
224143	14,000	-1,600	0,000	2,429	4,875	7,360	9,905	12,488	14,888	16,687	17,924	19,257	19,521	18,922
227572	14,200	-1,600	0,000	2,414	4,845	7,314	9,843	12,417	14,820	16,603	17,833	19,153	19,453	18,870
231006	14,400	-1,600	0,000	2,400	4,816	7,270	9,784	12,348	14,749	16,523	17,750	19,081	19,386	18,818
234447	14,600	-1,600	0,000	2,386	4,789	7,228	9,726	12,281	14,679	16,437	17,659	19,029	19,303	18,765
237893	14,800	-1,600	0,000	2,374	4,763	7,188	9,672	12,216	14,604	16,353	17,559	18,913	19,238	18,713
241347	15,000	-1,600	0,000	2,361	4,738	7,149	9,619	12,154	14,530	16,266	17,479	18,835	19,214	18,661
244806	15,200	-1,600	0,000	2,350	4,714	7,112	9,568	12,093	14,453	16,189	17,390	18,752	19,093	18,609
248272	15,400	-1,600	0,000	2,338	4,691	7,077	9,520	12,035	14,376	16,090	17,315	18,713	19,015	18,556
251744	15,600	-1,600	0,000	2,328	4,669	7,043	9,474	11,978	14,298	16,001	17,199	18,587	18,953	18,503

PETROLERO VLCC DE 300.000 TPM

CUADERNO IV: COMPARTIMENTADO Y CÁLCULOS DE ARQUITECTURA NAVAL

PEDRO LEMOS GONZÁLEZ

Displacement (intact) tonne	Draft Amidships m	Trim (+ve by stern) m	TCG m	KN 5,0 deg. Starb.	KN 10,0 deg. Starb.	KN 15,0 deg. Starb.	KN 20,0 deg. Starb.	KN 25,0 deg. Starb.	KN 30,0 deg. Starb.	KN 35,0 deg. Starb.	KN 40,0 deg. Starb.	KN 50,0 deg. Starb.	KN 60,0 deg. Starb.	KN 70,0 deg. Starb.
255222	15,800	-1,600	0,000	2,317	4,648	7,011	9,429	11,923	14,219	15,912	17,130	18,480	18,880	18,451
258707	16,000	-1,600	0,000	2,307	4,628	6,980	9,387	11,870	14,141	15,820	17,008	18,395	18,807	18,398
262197	16,200	-1,600	0,000	2,298	4,608	6,950	9,346	11,817	14,057	15,728	16,933	18,341	18,733	18,345
265693	16,400	-1,600	0,000	2,289	4,590	6,922	9,307	11,765	13,973	15,633	16,834	18,354	18,659	18,291
269195	16,600	-1,600	0,000	2,280	4,573	6,895	9,270	11,714	13,889	15,543	16,726	18,105	18,585	18,238
272702	16,800	-1,600	0,000	2,272	4,556	6,869	9,235	11,663	13,804	15,449	16,621	18,059	18,511	18,184
276215	17,000	-1,600	0,000	2,264	4,540	6,845	9,201	11,611	13,721	15,373	16,533	17,976	18,438	18,130
279734	17,200	-1,600	0,000	2,257	4,525	6,822	9,169	11,560	13,638	15,252	16,422	17,874	18,363	18,076
283260	17,400	-1,600	0,000	2,250	4,511	6,799	9,138	11,507	13,552	15,155	16,327	17,766	18,288	18,022
286790	17,600	-1,600	0,000	2,243	4,497	6,778	9,109	11,454	13,471	15,053	16,239	17,703	18,213	17,968
290326	17,800	-1,600	0,000	2,236	4,484	6,758	9,081	11,401	13,379	14,962	16,134	17,612	18,137	17,913
293867	18,000	-1,600	0,000	2,230	4,472	6,739	9,054	11,349	13,294	14,858	16,077	17,521	18,061	17,859
297414	18,200	-1,600	0,000	2,224	4,460	6,721	9,030	11,294	13,208	14,751	15,930	17,430	17,985	17,771
300964	18,400	-1,600	0,000	2,219	4,449	6,704	9,006	11,239	13,122	14,660	15,830	17,337	17,908	17,716
304519	18,600	-1,600	0,000	2,214	4,439	6,688	8,983	11,184	13,036	14,553	15,740	17,244	17,831	17,661
308079	18,800	-1,600	0,000	2,209	4,429	6,672	8,962	11,129	12,952	14,453	15,686	17,150	17,754	17,606
311642	19,000	-1,600	0,000	2,204	4,419	6,658	8,941	11,073	12,859	14,356	15,531	17,055	17,677	17,551
315209	19,200	-1,600	0,000	2,200	4,410	6,644	8,920	11,016	12,776	14,287	15,438	16,961	17,600	17,496
318780	19,400	-1,600	0,000	2,195	4,402	6,632	8,899	10,959	12,693	14,147	15,338	16,866	17,522	17,440
322355	19,600	-1,600	0,000	2,192	4,394	6,619	8,877	10,902	12,606	14,070	15,235	16,770	17,444	17,385
325934	19,800	-1,600	0,000	2,188	4,387	6,608	8,855	10,847	12,520	13,969	15,132	16,674	17,366	17,329
329516	20,000	-1,600	0,000	2,185	4,380	6,598	8,831	10,785	12,439	13,848	15,029	16,578	17,288	17,274
333102	20,200	-1,600	0,000	2,181	4,374	6,588	8,806	10,725	12,357	13,767	14,925	16,481	17,210	17,219
336692	20,400	-1,600	0,000	2,179	4,368	6,579	8,779	10,666	12,255	13,656	14,820	16,384	17,131	17,163
340285	20,600	-1,600	0,000	2,176	4,362	6,570	8,752	10,605	12,188	13,557	14,715	16,287	17,015	17,108
343882	20,800	-1,600	0,000	2,173	4,357	6,562	8,721	10,544	12,100	13,459	14,609	16,189	16,936	17,053
347482	21,000	-1,600	0,000	2,171	4,353	6,555	8,690	10,482	12,013	13,361	14,502	16,091	16,857	16,998
351087	21,200	-1,600	0,000	2,169	4,348	6,549	8,658	10,421	11,934	13,263	14,396	15,992	16,777	16,942
354695	21,400	-1,600	0,000	2,167	4,345	6,543	8,623	10,357	11,851	13,165	14,289	15,894	16,697	16,886
358307	21,600	-1,600	0,000	2,166	4,341	6,538	8,587	10,297	11,769	13,068	14,183	15,794	16,617	16,830
361923	21,800	-1,600	0,000	2,164	4,338	6,533	8,549	10,231	11,686	12,971	14,076	15,695	16,537	16,775
365542	22,000	-1,600	0,000	2,163	4,335	6,527	8,511	10,166	11,604	12,874	13,970	15,595	16,457	16,719
369166	22,200	-1,600	0,000	2,162	4,333	6,520	8,470	10,101	11,522	12,778	13,864	15,495	16,375	16,663
372792	22,400	-1,600	0,000	2,161	4,331	6,512	8,428	10,035	11,440	12,682	13,758	15,395	16,294	16,607
376423	22,600	-1,600	0,000	2,161	4,329	6,502	8,385	9,968	11,357	12,587	13,652	15,294	16,213	16,551

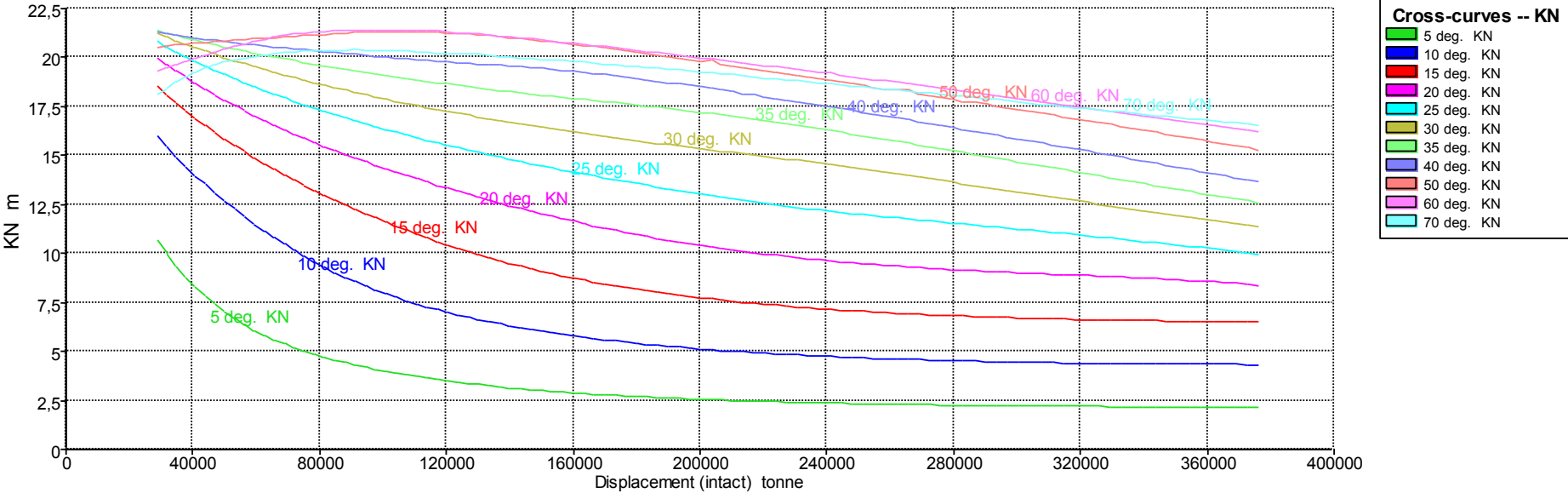

- Para un trimado de -3,2 m:

Displacement (intact) tonne	Draft Amidships m	Trim (+ve by stern) m	TCG m	KN 5,0 deg. Starb.	KN 10,0 deg. Starb.	KN 15,0 deg. Starb.	KN 20,0 deg. Starb.	KN 25,0 deg. Starb.	KN 30,0 deg. Starb.	KN 35,0 deg. Starb.	KN 40,0 deg. Starb.	KN 50,0 deg. Starb.	KN 60,0 deg. Starb.	KN 70,0 deg. Starb.
29746	2,000	-3,200	0,000	10,229	15,503	18,086	19,585	20,484	20,977	21,169	21,123	20,489	19,418	18,361
32753	2,200	-3,200	0,000	9,627	15,028	17,715	19,292	20,259	20,813	21,061	21,068	20,542	19,585	18,612
35780	2,400	-3,200	0,000	9,062	14,563	17,350	19,004	20,034	20,649	20,952	21,013	20,593	19,735	18,841
38824	2,600	-3,200	0,000	8,539	14,109	16,992	18,719	19,813	20,485	20,844	20,957	20,641	19,897	19,066
41885	2,800	-3,200	0,000	8,059	13,668	16,641	18,441	19,595	20,324	20,737	20,902	20,687	20,040	19,252
44961	3,000	-3,200	0,000	7,622	13,242	16,299	18,168	19,382	20,166	20,631	20,847	20,731	20,189	19,426
48051	3,200	-3,200	0,000	7,225	12,830	15,965	17,901	19,173	20,010	20,528	20,793	20,774	20,328	19,575
51153	3,400	-3,200	0,000	6,869	12,433	15,640	17,640	18,969	19,859	20,425	20,739	20,815	20,464	19,720
54266	3,600	-3,200	0,000	6,547	12,048	15,323	17,386	18,770	19,710	20,325	20,686	20,855	20,592	19,830
57391	3,800	-3,200	0,000	6,256	11,678	15,017	17,138	18,575	19,564	20,226	20,634	20,893	20,710	19,929
60525	4,000	-3,200	0,000	5,991	11,321	14,718	16,896	18,385	19,422	20,130	20,582	20,931	20,818	20,017
63669	4,200	-3,200	0,000	5,749	10,977	14,428	16,659	18,198	19,282	20,035	20,532	20,966	20,916	20,075
66822	4,400	-3,200	0,000	5,528	10,646	14,146	16,428	18,017	19,146	19,942	20,482	21,002	21,003	20,147
69984	4,600	-3,200	0,000	5,324	10,327	13,872	16,203	17,839	19,012	19,851	20,432	21,036	21,090	20,213
73154	4,800	-3,200	0,000	5,136	10,021	13,605	15,984	17,664	18,881	19,761	20,384	21,070	21,151	20,234
76332	5,000	-3,200	0,000	4,962	9,729	13,346	15,770	17,494	18,753	19,674	20,336	21,103	21,207	20,260
79518	5,200	-3,200	0,000	4,801	9,449	13,094	15,561	17,327	18,628	19,589	20,289	21,111	21,261	20,282
82710	5,400	-3,200	0,000	4,652	9,184	12,848	15,357	17,164	18,504	19,505	20,243	21,164	21,292	20,311
85908	5,600	-3,200	0,000	4,513	8,932	12,609	15,158	17,004	18,384	19,421	20,199	21,193	21,320	20,283
89113	5,800	-3,200	0,000	4,384	8,695	12,376	14,964	16,848	18,265	19,340	20,155	21,217	21,344	20,299
92323	6,000	-3,200	0,000	4,263	8,471	12,148	14,774	16,695	18,149	19,260	20,112	21,235	21,352	20,319
95540	6,200	-3,200	0,000	4,151	8,260	11,927	14,589	16,545	18,035	19,183	20,069	21,251	21,360	20,314
98763	6,400	-3,200	0,000	4,045	8,061	11,711	14,407	16,399	17,923	19,105	20,027	21,262	21,361	20,310
101991	6,600	-3,200	0,000	3,946	7,873	11,501	14,230	16,256	17,813	19,030	19,986	21,269	21,410	20,294
105224	6,800	-3,200	0,000	3,853	7,696	11,296	14,057	16,116	17,705	18,956	19,945	21,277	21,348	20,291
108463	7,000	-3,200	0,000	3,766	7,528	11,096	13,887	15,978	17,600	18,884	19,906	21,267	21,329	20,266

PETROLERO VLCC DE 300.000 TPM

CUADERNO IV: COMPARTIMENTADO Y CÁLCULOS DE ARQUITECTURA NAVAL

PEDRO LEMOS GONZÁLEZ

Displacement (intact) tonne	Draft Amidships m	Trim (+ve by stern) m	TCG m	KN 5,0 deg. Starb.	KN 10,0 deg. Starb.	KN 15,0 deg. Starb.	KN 20,0 deg. Starb.	KN 25,0 deg. Starb.	KN 30,0 deg. Starb.	KN 35,0 deg. Starb.	KN 40,0 deg. Starb.	KN 50,0 deg. Starb.	KN 60,0 deg. Starb.	KN 70,0 deg. Starb.
111706	7,200	-3,200	0,000	3,684	7,369	10,902	13,720	15,843	17,497	18,806	19,867	21,258	21,319	20,253
114955	7,400	-3,200	0,000	3,606	7,219	10,713	13,558	15,711	17,396	18,742	19,829	21,243	21,292	20,228
118208	7,600	-3,200	0,000	3,533	7,076	10,530	13,398	15,582	17,296	18,672	19,791	21,222	21,260	20,215
121466	7,800	-3,200	0,000	3,464	6,941	10,353	13,242	15,455	17,199	18,605	19,754	21,195	21,235	20,180
124729	8,000	-3,200	0,000	3,398	6,813	10,182	13,088	15,330	17,104	18,539	19,717	21,169	21,202	20,152
127996	8,200	-3,200	0,000	3,336	6,692	10,017	12,938	15,208	17,010	18,474	19,681	21,136	21,164	20,109
131267	8,400	-3,200	0,000	3,278	6,577	9,859	12,791	15,088	16,918	18,410	19,645	21,103	21,135	20,072
134543	8,600	-3,200	0,000	3,223	6,467	9,707	12,647	14,971	16,828	18,347	19,607	21,057	21,084	20,105
137823	8,800	-3,200	0,000	3,170	6,363	9,562	12,505	14,855	16,739	18,286	19,569	21,011	21,064	20,022
141107	9,000	-3,200	0,000	3,120	6,264	9,422	12,366	14,741	16,652	18,226	19,528	20,967	20,992	19,984
144395	9,200	-3,200	0,000	3,073	6,171	9,289	12,230	14,630	16,566	18,166	19,486	20,915	20,951	19,931
147687	9,400	-3,200	0,000	3,028	6,081	9,161	12,097	14,520	16,482	18,108	19,442	20,870	20,901	19,921
150983	9,600	-3,200	0,000	2,985	5,996	9,038	11,966	14,412	16,399	18,051	19,396	20,812	20,904	19,865
154283	9,800	-3,200	0,000	2,944	5,915	8,921	11,838	14,307	16,318	17,995	19,349	20,758	20,819	19,831
157588	10,000	-3,200	0,000	2,906	5,838	8,809	11,713	14,202	16,238	17,940	19,295	20,696	20,741	19,802
160897	10,200	-3,200	0,000	2,869	5,765	8,701	11,591	14,100	16,160	17,884	19,243	20,634	20,676	19,746
164210	10,400	-3,200	0,000	2,834	5,695	8,598	11,472	13,999	16,082	17,829	19,189	20,568	20,624	19,724
167528	10,600	-3,200	0,000	2,800	5,628	8,499	11,356	13,900	16,007	17,774	19,131	20,503	20,571	19,661
170850	10,800	-3,200	0,000	2,769	5,564	8,404	11,243	13,803	15,932	17,719	19,070	20,440	20,514	19,632
174177	11,000	-3,200	0,000	2,738	5,503	8,313	11,133	13,707	15,858	17,660	19,009	20,371	20,448	19,602
177509	11,200	-3,200	0,000	2,709	5,445	8,227	11,026	13,612	15,786	17,602	18,945	20,299	20,393	19,520
180845	11,400	-3,200	0,000	2,682	5,390	8,144	10,924	13,520	15,715	17,543	18,880	20,233	20,327	19,518
184185	11,600	-3,200	0,000	2,656	5,337	8,064	10,824	13,428	15,644	17,482	18,810	20,152	20,267	19,462
187530	11,800	-3,200	0,000	2,630	5,287	7,988	10,728	13,339	15,575	17,420	18,740	20,070	20,207	19,416
190880	12,000	-3,200	0,000	2,607	5,238	7,915	10,636	13,250	15,507	17,357	18,667	20,005	20,137	19,370
194235	12,200	-3,200	0,000	2,584	5,192	7,845	10,546	13,164	15,441	17,292	18,591	19,941	20,072	19,315
197594	12,400	-3,200	0,000	2,562	5,148	7,779	10,460	13,078	15,374	17,225	18,527	19,854	20,015	19,287
200958	12,600	-3,200	0,000	2,541	5,106	7,715	10,377	12,995	15,308	17,157	18,440	19,793	19,978	19,221
204328	12,800	-3,200	0,000	2,521	5,066	7,653	10,297	12,913	15,243	17,086	18,365	19,702	19,877	19,232
207703	13,000	-3,200	0,000	2,502	5,027	7,595	10,220	12,832	15,178	17,016	18,283	19,616	19,821	19,164
211083	13,200	-3,200	0,000	2,484	4,990	7,539	10,146	12,753	15,111	16,941	18,205	19,544	19,744	19,095
214469	13,400	-3,200	0,000	2,467	4,955	7,485	10,074	12,676	15,044	16,866	18,125	19,455	19,656	19,045
217860	13,600	-3,200	0,000	2,451	4,921	7,433	10,005	12,600	14,977	16,788	18,054	19,366	19,608	18,994
221258	13,800	-3,200	0,000	2,435	4,889	7,384	9,939	12,526	14,909	16,711	17,956	19,286	19,541	18,943
224662	14,000	-3,200	0,000	2,420	4,858	7,337	9,876	12,455	14,841	16,630	17,873	19,205	19,479	18,892
228072	14,200	-3,200	0,000	2,405	4,829	7,292	9,815	12,385	14,771	16,554	17,783	19,123	19,382	18,841
231487	14,400	-3,200	0,000	2,392	4,801	7,248	9,756	12,317	14,700	16,484	17,695	19,044	19,344	18,789
234909	14,600	-3,200	0,000	2,378	4,774	7,207	9,700	12,251	14,628	16,384	17,607	18,962	19,279	18,738
238337	14,800	-3,200	0,000	2,366	4,748	7,167	9,646	12,188	14,554	16,297	17,531	18,863	19,200	18,686
241771	15,000	-3,200	0,000	2,354	4,724	7,129	9,594	12,126	14,480	16,219	17,428	18,778	19,134	18,635

PETROLERO VLCC DE 300.000 TPM

CUADERNO IV: COMPARTIMENTADO Y CÁLCULOS DE ARQUITECTURA NAVAL

PEDRO LEMOS GONZÁLEZ

Displacement (intact) tonne	Draft Amidships m	Trim (+ve by stern) m	TCG m	KN 5,0 deg. Starb.	KN 10,0 deg. Starb.	KN 15,0 deg. Starb.	KN 20,0 deg. Starb.	KN 25,0 deg. Starb.	KN 30,0 deg. Starb.	KN 35,0 deg. Starb.	KN 40,0 deg. Starb.	KN 50,0 deg. Starb.	KN 60,0 deg. Starb.	KN 70,0 deg. Starb.
245211	15,200	-3,200	0,000	2,342	4,700	7,093	9,545	12,067	14,405	16,124	17,331	18,701	19,063	18,583
248657	15,400	-3,200	0,000	2,331	4,678	7,058	9,497	12,009	14,328	16,051	17,245	18,633	18,991	18,530
252110	15,600	-3,200	0,000	2,321	4,656	7,025	9,452	11,952	14,250	15,951	17,152	18,536	18,917	18,478
255568	15,800	-3,200	0,000	2,311	4,635	6,994	9,408	11,896	14,170	15,862	17,061	18,441	18,844	18,425
259033	16,000	-3,200	0,000	2,301	4,616	6,963	9,367	11,842	14,089	15,776	16,963	18,359	18,771	18,372
262504	16,200	-3,200	0,000	2,292	4,597	6,934	9,327	11,788	14,009	15,676	16,857	18,275	18,699	18,318
265981	16,400	-3,200	0,000	2,283	4,579	6,907	9,289	11,735	13,927	15,585	16,776	18,193	18,625	18,264
269464	16,600	-3,200	0,000	2,275	4,562	6,881	9,253	11,682	13,844	15,488	16,678	18,098	18,551	18,211
272953	16,800	-3,200	0,000	2,267	4,546	6,856	9,218	11,630	13,763	15,397	16,589	18,004	18,477	18,157
276447	17,000	-3,200	0,000	2,259	4,531	6,831	9,185	11,578	13,677	15,301	16,486	17,927	18,401	18,103
279948	17,200	-3,200	0,000	2,252	4,516	6,809	9,153	11,527	13,592	15,204	16,386	17,839	18,326	18,049
283454	17,400	-3,200	0,000	2,245	4,502	6,787	9,123	11,473	13,507	15,109	16,285	17,752	18,251	17,995
286965	17,600	-3,200	0,000	2,239	4,489	6,767	9,095	11,421	13,424	15,008	16,188	17,663	18,176	17,906
290482	17,800	-3,200	0,000	2,233	4,476	6,747	9,067	11,370	13,341	14,915	16,084	17,573	18,100	17,852
294006	18,000	-3,200	0,000	2,227	4,464	6,728	9,042	11,316	13,254	14,814	15,988	17,481	18,024	17,797
297535	18,200	-3,200	0,000	2,221	4,453	6,711	9,017	11,261	13,168	14,703	15,896	17,389	17,948	17,742
301070	18,400	-3,200	0,000	2,216	4,442	6,694	8,994	11,206	13,083	14,611	15,784	17,295	17,872	17,687
304609	18,600	-3,200	0,000	2,210	4,432	6,679	8,971	11,152	12,997	14,515	15,696	17,202	17,795	17,632
308154	18,800	-3,200	0,000	2,206	4,423	6,664	8,948	11,096	12,907	14,424	15,596	17,108	17,718	17,576
311704	19,000	-3,200	0,000	2,201	4,414	6,650	8,926	11,041	12,824	14,322	15,495	17,014	17,641	17,522
315258	19,200	-3,200	0,000	2,197	4,405	6,637	8,904	10,985	12,738	14,200	15,394	16,919	17,564	17,467
318817	19,400	-3,200	0,000	2,193	4,397	6,624	8,881	10,928	12,653	14,118	15,292	16,824	17,487	17,412
322381	19,600	-3,200	0,000	2,189	4,390	6,613	8,858	10,875	12,571	14,013	15,190	16,729	17,409	17,356
325948	19,800	-3,200	0,000	2,186	4,383	6,602	8,834	10,812	12,488	13,913	15,086	16,633	17,293	17,301
329520	20,000	-3,200	0,000	2,183	4,376	6,592	8,809	10,756	12,404	13,813	14,983	16,537	17,215	17,246
333097	20,200	-3,200	0,000	2,180	4,370	6,582	8,783	10,700	12,325	13,714	14,880	16,440	17,136	17,191
336677	20,400	-3,200	0,000	2,177	4,364	6,574	8,756	10,641	12,234	13,615	14,776	16,344	17,057	17,136
340262	20,600	-3,200	0,000	2,175	4,359	6,566	8,728	10,576	12,150	13,517	14,673	16,247	16,979	17,080
343851	20,800	-3,200	0,000	2,172	4,354	6,558	8,698	10,514	12,067	13,419	14,568	16,149	16,899	17,025
347445	21,000	-3,200	0,000	2,170	4,350	6,552	8,667	10,455	11,983	13,321	14,463	16,051	16,820	16,969
351042	21,200	-3,200	0,000	2,168	4,346	6,546	8,634	10,393	11,900	13,223	14,357	15,953	16,741	16,914
354644	21,400	-3,200	0,000	2,167	4,342	6,539	8,600	10,331	11,817	13,126	14,251	15,855	16,661	16,858
358249	21,600	-3,200	0,000	2,165	4,339	6,533	8,564	10,267	11,735	13,030	14,145	15,756	16,581	16,803
361859	21,800	-3,200	0,000	2,164	4,337	6,526	8,526	10,204	11,653	12,934	14,038	15,657	16,501	16,747
365473	22,000	-3,200	0,000	2,163	4,334	6,518	8,487	10,139	11,571	12,838	13,932	15,558	16,421	16,691
369090	22,200	-3,200	0,000	2,162	4,332	6,509	8,447	10,074	11,489	12,743	13,827	15,459	16,340	16,635
372712	22,400	-3,200	0,000	2,161	4,330	6,498	8,405	10,008	11,407	12,648	13,721	15,359	16,260	16,579
376337	22,600	-3,200	0,000	2,160	4,329	6,486	8,361	9,941	11,326	12,553	13,617	15,220	16,179	16,523

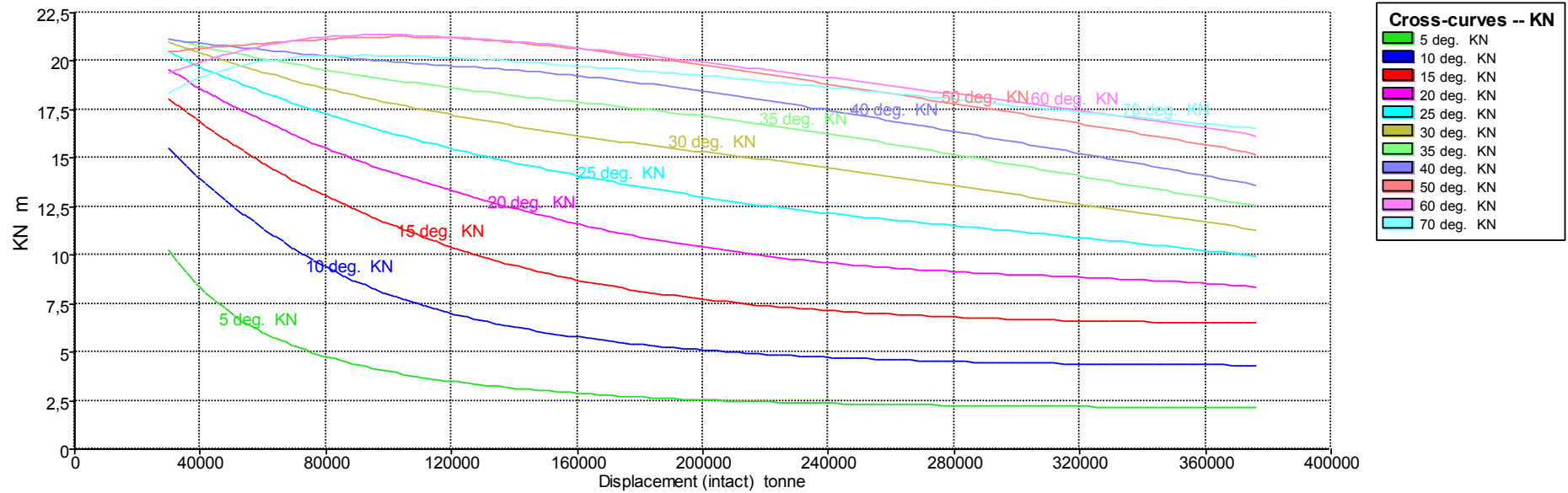

- Para un trimado de -4,8 m:

Displacement (intact) tonne	Draft Amidships m	Trim (+ve by stern) m	TCG m	KN 5,0 deg. Starb.	KN 10,0 deg. Starb.	KN 15,0 deg. Starb.	KN 20,0 deg. Starb.	KN 25,0 deg. Starb.	KN 30,0 deg. Starb.	KN 35,0 deg. Starb.	KN 40,0 deg. Starb.	KN 50,0 deg. Starb.	KN 60,0 deg. Starb.	KN 70,0 deg. Starb.
30817	2,000	-4,800	0,000	9,613	14,782	17,429	19,003	19,982	20,563	20,844	20,887	20,449	19,592	18,637
33798	2,200	-4,800	0,000	9,146	14,412	17,145	18,785	19,818	20,446	20,773	20,858	20,503	19,730	18,812
36812	2,400	-4,800	0,000	8,687	14,031	16,851	18,556	19,644	20,322	20,695	20,824	20,556	19,871	18,980
39847	2,600	-4,800	0,000	8,246	13,647	16,551	18,322	19,465	20,192	20,611	20,787	20,605	20,015	19,139
42900	2,800	-4,800	0,000	7,826	13,264	16,249	18,085	19,283	20,060	20,525	20,746	20,652	20,142	19,291

PETROLERO VLCC DE 300.000 TPM

CUADERNO IV: COMPARTIMENTADO Y CÁLCULOS DE ARQUITECTURA NAVAL

PEDRO LEMOS GONZÁLEZ

Displacement (intact) tonne	Draft Amidships m	Trim (+ve by stern) m	TCG m	KN 5,0 deg. Starb.	KN 10,0 deg. Starb.	KN 15,0 deg. Starb.	KN 20,0 deg. Starb.	KN 25,0 deg. Starb.	KN 30,0 deg. Starb.	KN 35,0 deg. Starb.	KN 40,0 deg. Starb.	KN 50,0 deg. Starb.	KN 60,0 deg. Starb.	KN 70,0 deg. Starb.
45970	3,000	-4,800	0,000	7,433	12,884	15,949	17,848	19,099	19,925	20,438	20,704	20,698	20,270	19,433
49053	3,200	-4,800	0,000	7,069	12,511	15,651	17,612	18,916	19,790	20,349	20,661	20,743	20,392	19,555
52151	3,400	-4,800	0,000	6,734	12,145	15,356	17,378	18,734	19,656	20,260	20,616	20,785	20,506	19,671
55260	3,600	-4,800	0,000	6,428	11,789	15,066	17,146	18,554	19,523	20,171	20,572	20,827	20,620	19,774
58381	3,800	-4,800	0,000	6,149	11,443	14,781	16,918	18,376	19,390	20,082	20,527	20,866	20,713	19,861
61513	4,000	-4,800	0,000	5,895	11,107	14,500	16,693	18,200	19,260	19,996	20,480	20,907	20,812	19,930
64654	4,200	-4,800	0,000	5,662	10,782	14,226	16,472	18,027	19,131	19,909	20,437	20,943	20,891	20,014
67805	4,400	-4,800	0,000	5,448	10,468	13,957	16,254	17,857	19,005	19,825	20,392	20,980	20,965	20,076
70963	4,600	-4,800	0,000	5,251	10,166	13,695	16,041	17,690	18,880	19,741	20,347	21,015	21,049	20,121
74128	4,800	-4,800	0,000	5,069	9,876	13,439	15,831	17,525	18,757	19,657	20,304	21,049	21,089	20,123
77301	5,000	-4,800	0,000	4,901	9,597	13,189	15,626	17,363	18,637	19,575	20,260	21,079	21,141	20,189
80482	5,200	-4,800	0,000	4,745	9,331	12,943	15,425	17,204	18,518	19,495	20,206	21,109	21,181	20,215
83669	5,400	-4,800	0,000	4,600	9,077	12,706	15,227	17,047	18,401	19,416	20,175	21,135	21,219	20,311
86864	5,600	-4,800	0,000	4,465	8,835	12,474	15,034	16,894	18,286	19,338	20,134	21,158	21,247	20,240
90064	5,800	-4,800	0,000	4,339	8,605	12,247	14,845	16,743	18,172	19,261	20,093	21,177	21,265	20,222
93271	6,000	-4,800	0,000	4,221	8,387	12,026	14,660	16,595	18,061	19,186	20,053	21,184	21,276	20,209
96483	6,200	-4,800	0,000	4,111	8,182	11,810	14,479	16,449	17,951	19,111	20,013	21,201	21,287	20,247
99702	6,400	-4,800	0,000	4,008	7,988	11,600	14,301	16,306	17,843	19,038	19,973	21,204	21,287	20,243
102925	6,600	-4,800	0,000	3,912	7,804	11,394	14,127	16,166	17,737	18,966	19,937	21,209	21,277	20,228
106154	6,800	-4,800	0,000	3,821	7,631	11,195	13,957	16,029	17,632	18,896	19,892	21,206	21,272	20,261
109388	7,000	-4,800	0,000	3,735	7,467	11,000	13,790	15,894	17,530	18,825	19,860	21,196	21,208	20,200
112627	7,200	-4,800	0,000	3,655	7,311	10,811	13,627	15,762	17,429	18,757	19,819	21,192	21,338	20,187
115870	7,400	-4,800	0,000	3,579	7,164	10,628	13,467	15,632	17,330	18,689	19,789	21,181	21,230	20,172
119117	7,600	-4,800	0,000	3,507	7,024	10,450	13,310	15,505	17,233	18,622	19,752	21,145	21,194	20,138
122369	7,800	-4,800	0,000	3,439	6,892	10,277	13,156	15,380	17,137	18,557	19,717	21,123	21,171	20,119
125626	8,000	-4,800	0,000	3,375	6,766	10,111	13,005	15,257	17,043	18,492	19,683	21,095	21,132	20,088
128887	8,200	-4,800	0,000	3,315	6,647	9,950	12,857	15,137	16,951	18,429	19,643	21,096	21,089	20,070
132152	8,400	-4,800	0,000	3,257	6,534	9,795	12,712	15,018	16,861	18,366	19,605	21,029	21,061	20,036
135421	8,600	-4,800	0,000	3,203	6,427	9,646	12,570	14,902	16,772	18,305	19,565	20,977	21,018	20,011
138694	8,800	-4,800	0,000	3,151	6,324	9,503	12,431	14,788	16,684	18,245	19,524	20,943	20,970	19,967
141972	9,000	-4,800	0,000	3,102	6,227	9,366	12,294	14,676	16,599	18,186	19,481	20,897	20,925	19,983
145253	9,200	-4,800	0,000	3,055	6,135	9,235	12,160	14,565	16,514	18,128	19,437	20,848	20,887	19,906
148538	9,400	-4,800	0,000	3,011	6,047	9,109	12,029	14,457	16,431	18,071	19,390	20,799	20,831	19,841
151826	9,600	-4,800	0,000	2,969	5,964	8,989	11,901	14,350	16,349	18,014	19,341	20,737	20,790	19,817
155119	9,800	-4,800	0,000	2,929	5,884	8,874	11,775	14,246	16,269	17,958	19,295	20,689	20,738	19,787
158416	10,000	-4,800	0,000	2,891	5,808	8,763	11,653	14,143	16,190	17,901	19,240	20,620	20,693	19,728
161716	10,200	-4,800	0,000	2,855	5,736	8,657	11,533	14,042	16,113	17,845	19,186	20,564	20,626	19,716
165021	10,400	-4,800	0,000	2,820	5,667	8,555	11,416	13,942	16,036	17,790	19,129	20,508	20,567	19,695
168329	10,600	-4,800	0,000	2,787	5,601	8,458	11,302	13,844	15,961	17,732	19,072	20,442	20,513	19,686
171642	10,800	-4,800	0,000	2,756	5,538	8,365	11,191	13,748	15,887	17,674	19,008	20,369	20,454	19,580

PETROLERO VLCC DE 300.000 TPM

CUADERNO IV: COMPARTIMENTADO Y CÁLCULOS DE ARQUITECTURA NAVAL

PEDRO LEMOS GONZÁLEZ

Displacement (intact) tonne	Draft Amidships m	Trim (+ve by stern) m	TCG m	KN 5,0 deg. Starb.	KN 10,0 deg. Starb.	KN 15,0 deg. Starb.	KN 20,0 deg. Starb.	KN 25,0 deg. Starb.	KN 30,0 deg. Starb.	KN 35,0 deg. Starb.	KN 40,0 deg. Starb.	KN 50,0 deg. Starb.	KN 60,0 deg. Starb.	KN 70,0 deg. Starb.
174958	11,000	-4,800	0,000	2,726	5,478	8,276	11,084	13,654	15,815	17,614	18,947	20,301	20,390	19,542
178279	11,200	-4,800	0,000	2,697	5,421	8,190	10,979	13,560	15,743	17,552	18,882	20,230	20,332	19,541
181604	11,400	-4,800	0,000	2,670	5,367	8,109	10,878	13,469	15,674	17,491	18,817	20,173	20,267	19,492
184934	11,600	-4,800	0,000	2,644	5,315	8,031	10,781	13,379	15,604	17,429	18,750	20,103	20,212	19,443
188268	11,800	-4,800	0,000	2,620	5,265	7,956	10,686	13,291	15,536	17,365	18,680	20,019	20,157	19,335
191606	12,000	-4,800	0,000	2,596	5,217	7,884	10,595	13,204	15,467	17,300	18,607	19,944	20,094	19,340
194949	12,200	-4,800	0,000	2,573	5,172	7,815	10,507	13,118	15,400	17,232	18,544	19,868	19,982	19,250
198296	12,400	-4,800	0,000	2,552	5,128	7,750	10,422	13,035	15,333	17,165	18,460	19,802	19,965	19,252
201647	12,600	-4,800	0,000	2,532	5,087	7,687	10,341	12,952	15,266	17,096	18,383	19,714	19,890	19,194
205004	12,800	-4,800	0,000	2,512	5,047	7,626	10,262	12,872	15,199	17,026	18,294	19,639	19,820	19,149
208365	13,000	-4,800	0,000	2,493	5,009	7,569	10,186	12,793	15,133	16,953	18,219	19,563	19,772	19,102
211731	13,200	-4,800	0,000	2,475	4,973	7,514	10,113	12,715	15,064	16,889	18,141	19,468	19,698	19,055
215102	13,400	-4,800	0,000	2,458	4,938	7,461	10,043	12,639	14,995	16,806	18,058	19,380	19,660	19,007
218478	13,600	-4,800	0,000	2,442	4,905	7,410	9,975	12,565	14,928	16,731	17,977	19,324	19,565	18,957
221859	13,800	-4,800	0,000	2,427	4,874	7,362	9,910	12,493	14,860	16,653	17,897	19,235	19,509	18,907
225246	14,000	-4,800	0,000	2,412	4,843	7,315	9,848	12,423	14,787	16,579	17,809	19,121	19,427	18,857
228638	14,200	-4,800	0,000	2,398	4,814	7,271	9,788	12,355	14,716	16,489	17,725	19,068	19,375	18,807
232036	14,400	-4,800	0,000	2,384	4,787	7,228	9,731	12,288	14,644	16,406	17,639	19,137	19,296	18,756
235440	14,600	-4,800	0,000	2,371	4,760	7,188	9,676	12,224	14,573	16,329	17,547	18,920	19,227	18,706
238850	14,800	-4,800	0,000	2,359	4,735	7,149	9,623	12,161	14,498	16,237	17,463	18,821	19,158	18,654
242265	15,000	-4,800	0,000	2,347	4,711	7,112	9,572	12,100	14,423	16,156	17,371	18,742	19,089	18,603
245687	15,200	-4,800	0,000	2,336	4,688	7,076	9,524	12,040	14,348	16,058	17,273	18,635	19,018	18,551
249114	15,400	-4,800	0,000	2,325	4,666	7,042	9,477	11,982	14,271	15,983	17,184	18,571	18,948	18,498
252547	15,600	-4,800	0,000	2,315	4,645	7,010	9,433	11,924	14,198	15,891	17,093	18,472	18,877	18,445
255987	15,800	-4,800	0,000	2,305	4,625	6,979	9,390	11,868	14,114	15,800	16,991	18,406	18,805	18,393
259433	16,000	-4,800	0,000	2,296	4,606	6,949	9,350	11,812	14,036	15,710	16,912	18,304	18,731	18,340
262885	16,200	-4,800	0,000	2,287	4,587	6,921	9,311	11,757	13,954	15,618	16,815	18,222	18,657	18,286
266343	16,400	-4,800	0,000	2,278	4,570	6,894	9,274	11,702	13,874	15,544	16,722	18,135	18,583	18,232
269807	16,600	-4,800	0,000	2,270	4,553	6,868	9,238	11,648	13,793	15,433	16,614	18,049	18,509	18,179
273276	16,800	-4,800	0,000	2,263	4,538	6,843	9,204	11,595	13,709	15,327	16,529	17,963	18,434	18,089
276752	17,000	-4,800	0,000	2,255	4,523	6,820	9,172	11,541	13,622	15,249	16,423	17,876	18,359	18,035
280234	17,200	-4,800	0,000	2,248	4,508	6,798	9,141	11,488	13,542	15,147	16,325	17,788	18,283	17,981
283721	17,400	-4,800	0,000	2,241	4,495	6,777	9,112	11,436	13,460	15,053	16,230	17,699	18,208	17,926
287213	17,600	-4,800	0,000	2,235	4,482	6,757	9,084	11,383	13,373	14,952	16,123	17,609	18,133	17,872
290712	17,800	-4,800	0,000	2,229	4,470	6,738	9,057	11,330	13,288	14,859	16,027	17,518	18,057	17,817
294217	18,000	-4,800	0,000	2,223	4,458	6,720	9,031	11,276	13,191	14,787	15,938	17,428	17,981	17,763
297728	18,200	-4,800	0,000	2,218	4,447	6,703	9,006	11,221	13,132	14,666	15,839	17,336	17,905	17,707
301244	18,400	-4,800	0,000	2,213	4,437	6,687	8,981	11,168	13,032	14,552	15,740	17,244	17,829	17,653
304765	18,600	-4,800	0,000	2,208	4,427	6,672	8,957	11,116	12,950	14,456	15,640	17,150	17,752	17,598
308293	18,800	-4,800	0,000	2,203	4,418	6,657	8,934	11,059	12,867	14,364	15,539	17,057	17,676	17,543

PETROLERO VLCC DE 300.000 TPM

CUADERNO IV: COMPARTIMENTADO Y CÁLCULOS DE ARQUITECTURA NAVAL

PEDRO LEMOS GONZÁLEZ

Displacement (intact) tonne	Draft Amidships m	Trim (+ve by stern) m	TCG m	KN 5,0 deg. Starb.	KN 10,0 deg. Starb.	KN 15,0 deg. Starb.	KN 20,0 deg. Starb.	KN 25,0 deg. Starb.	KN 30,0 deg. Starb.	KN 35,0 deg. Starb.	KN 40,0 deg. Starb.	KN 50,0 deg. Starb.	KN 60,0 deg. Starb.	KN 70,0 deg. Starb.
311827	19,000	-4,800	0,000	2,199	4,409	6,644	8,909	11,003	12,783	14,264	15,438	16,962	17,599	17,488
315367	19,200	-4,800	0,000	2,195	4,401	6,631	8,885	10,951	12,701	14,164	15,337	16,868	17,482	17,434
318912	19,400	-4,800	0,000	2,191	4,393	6,619	8,861	10,890	12,611	14,063	15,235	16,773	17,404	17,379
322462	19,600	-4,800	0,000	2,188	4,386	6,608	8,836	10,834	12,529	13,963	15,134	16,678	17,326	17,324
326019	19,800	-4,800	0,000	2,185	4,380	6,598	8,810	10,781	12,445	13,863	15,032	16,582	17,248	17,269
329580	20,000	-4,800	0,000	2,182	4,373	6,588	8,784	10,716	12,361	13,763	14,929	16,486	17,170	17,214
333147	20,200	-4,800	0,000	2,179	4,368	6,579	8,758	10,659	12,277	13,665	14,826	16,390	17,092	17,158
336718	20,400	-4,800	0,000	2,176	4,362	6,571	8,728	10,600	12,193	13,566	14,723	16,293	17,013	17,103
340295	20,600	-4,800	0,000	2,174	4,357	6,563	8,701	10,541	12,110	13,468	14,619	16,196	16,934	17,048
343875	20,800	-4,800	0,000	2,172	4,353	6,556	8,669	10,480	12,026	13,370	14,515	16,099	16,856	16,992
347461	21,000	-4,800	0,000	2,170	4,349	6,549	8,637	10,419	11,943	13,273	14,410	16,002	16,776	16,937
351051	21,200	-4,800	0,000	2,168	4,345	6,541	8,604	10,357	11,860	13,176	14,305	15,904	16,697	16,881
354645	21,400	-4,800	0,000	2,166	4,342	6,533	8,569	10,295	11,777	13,080	14,200	15,807	16,618	16,826
358244	21,600	-4,800	0,000	2,165	4,339	6,524	8,533	10,231	11,694	12,984	14,096	15,709	16,538	16,770
361847	21,800	-4,800	0,000	2,164	4,336	6,515	8,495	10,168	11,612	12,888	13,990	15,570	16,458	16,715
365454	22,000	-4,800	0,000	2,163	4,334	6,505	8,456	10,103	11,530	12,792	13,885	15,470	16,378	16,659
369066	22,200	-4,800	0,000	2,162	4,333	6,493	8,415	10,038	11,448	12,697	13,780	15,370	16,298	16,603
372681	22,400	-4,800	0,000	2,161	4,331	6,480	8,373	9,972	11,366	12,602	13,676	15,271	16,218	16,547
376301	22,600	-4,800	0,000	2,161	4,330	6,466	8,329	9,906	11,284	12,507	13,572	15,172	16,137	16,491

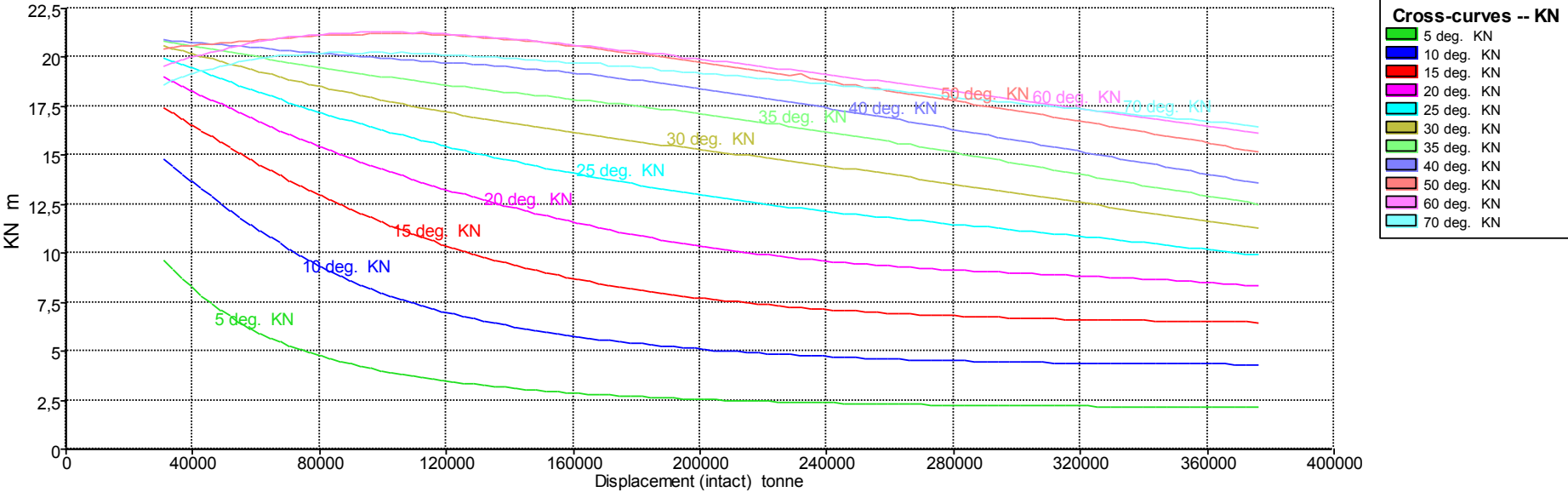

12 BIBLIOGRAFÍA.

- Convenio MARPOL.
- Proyecto de buques y artefactos; de Fernando Junco Ocampo.
- El proyecto básico del buque mercante; de Albariño, R, Azpiroz, JJ., Meizoso.
- Protocolo IGF.

Ferrol, junio de 2022

Fdo.: Pedro Lemos González

13 ANEJO I: VISTAS 3D DE MAXSURF STABILITY.



Ilustración 1



Ilustración 2

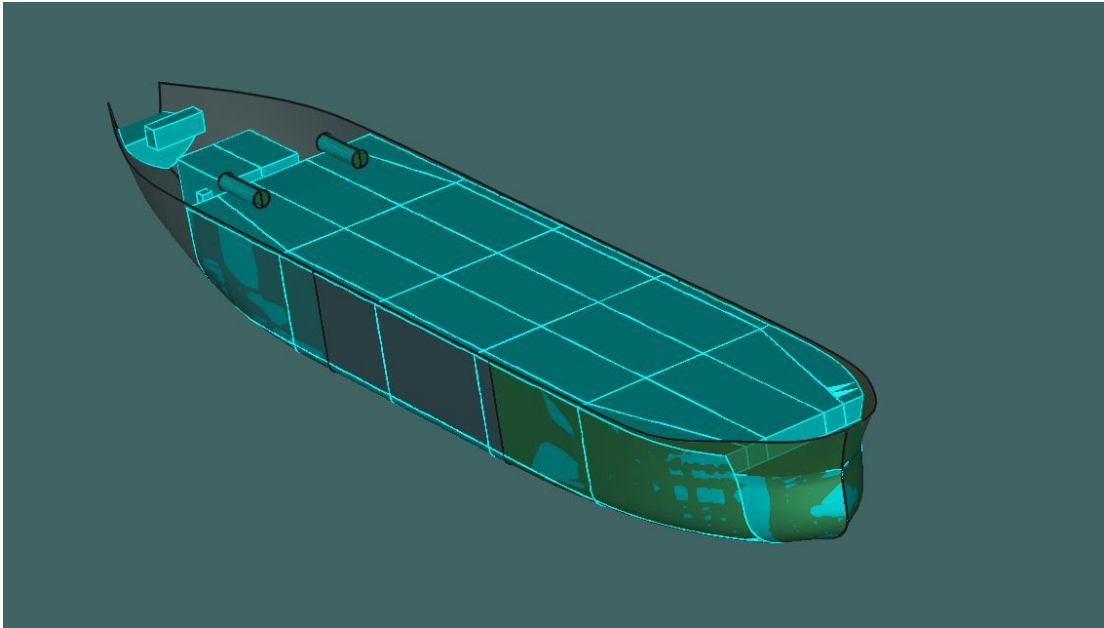

Ilustración 3

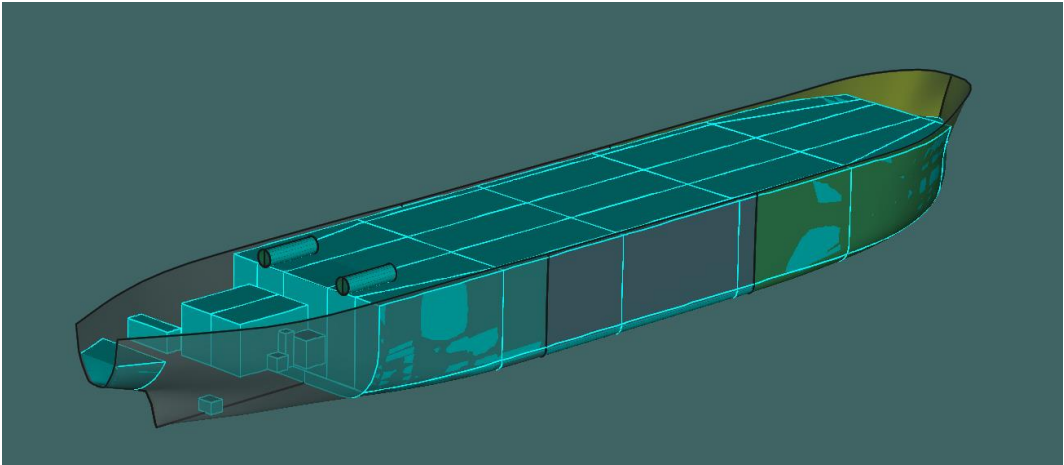

Ilustración 4

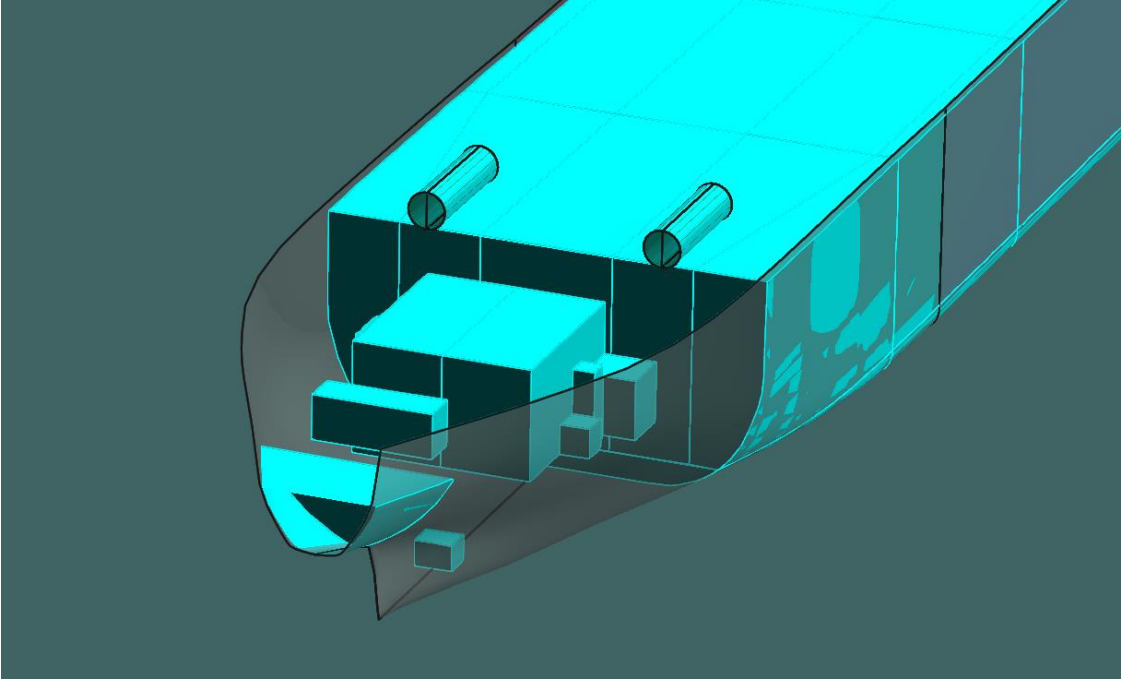

Ilustración 5

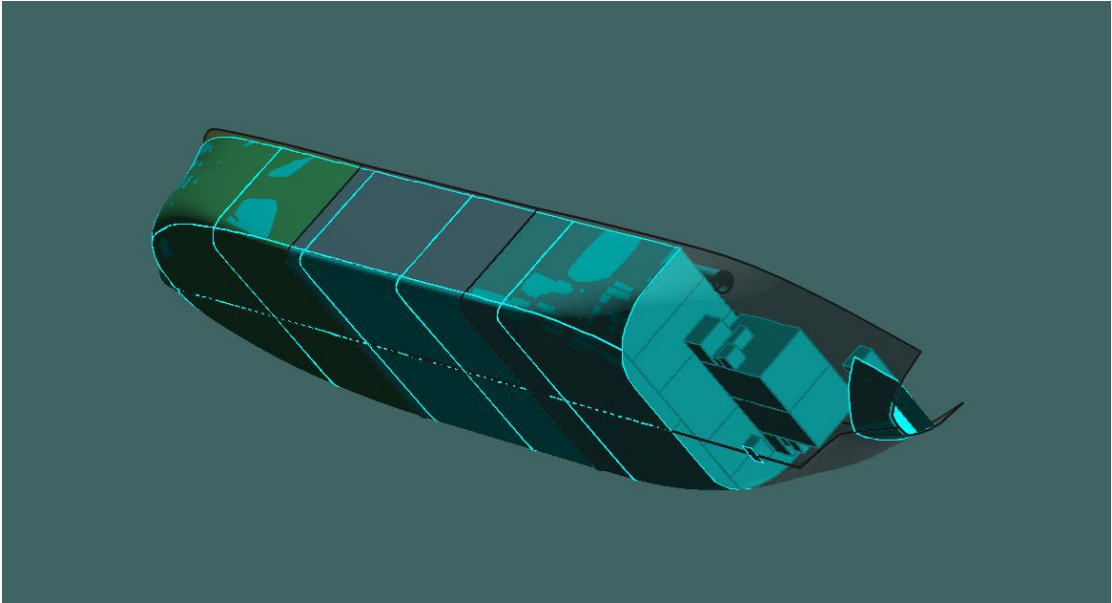

Ilustración 6

14 ANEJO II: PLANOS.

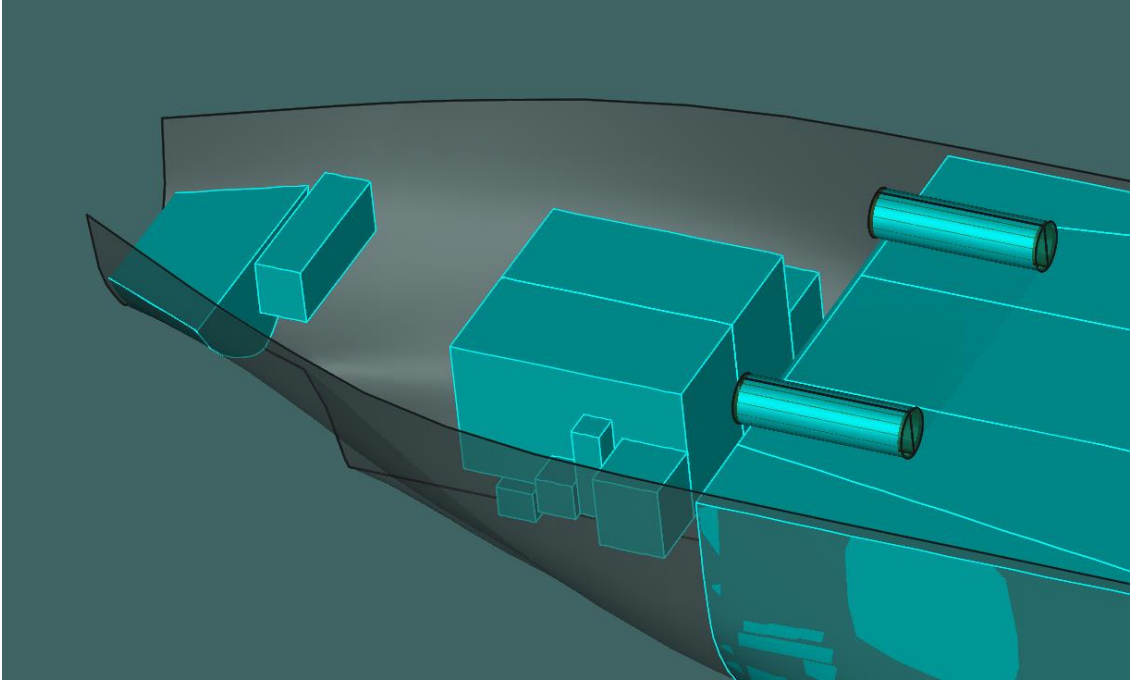

UNIVERSIDADE DA CORUÑA

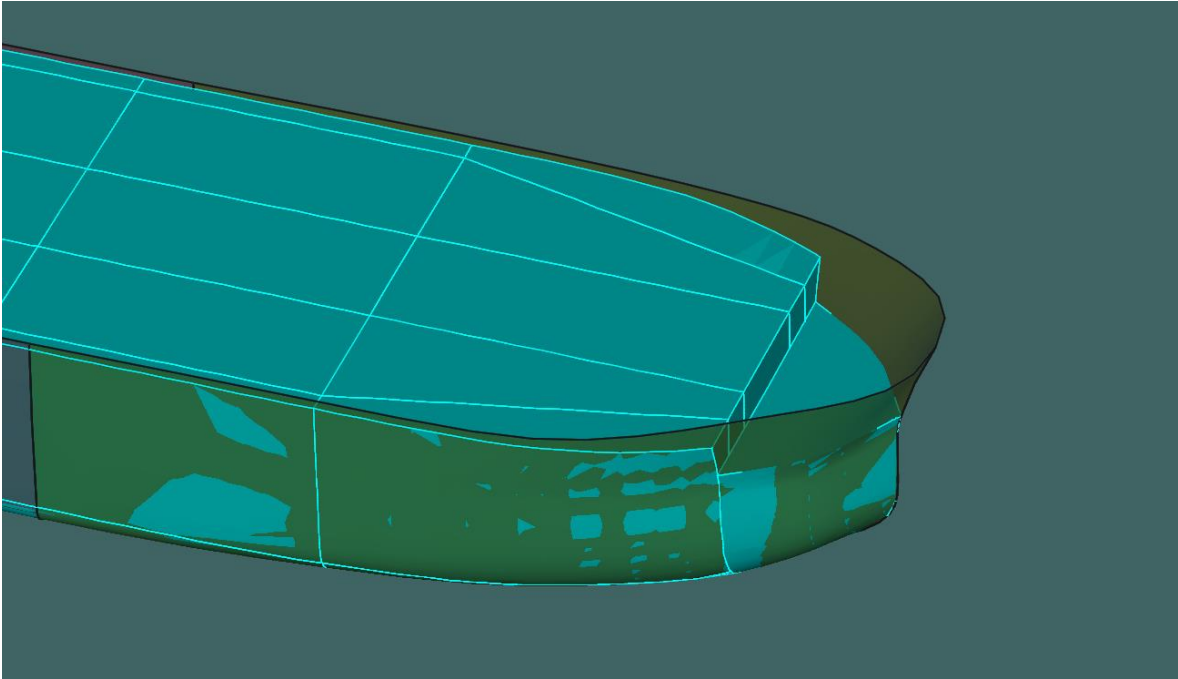
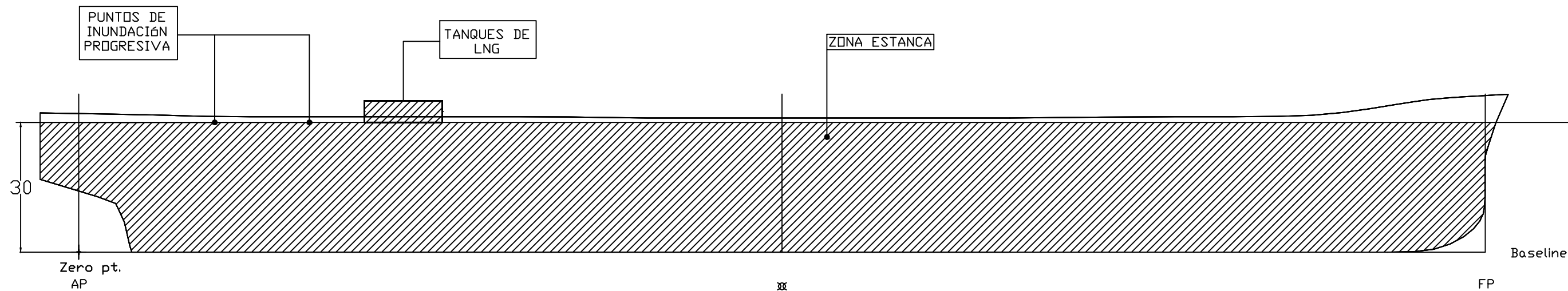
ESCUELA POLITÉCNICA SUPERIOR

TRABAJO DE FIN DE GRADO

PROYECTO:

PETROLERO VLCC DE 300.000 TPM

PLANO:

PLANO DE ZONA ESTANCA

AUTOR:

PEDRO LEMOS GONZÁLEZ

FECHA:

JUNIO 2022

ESCALA:

1:1000

HOJA:

1

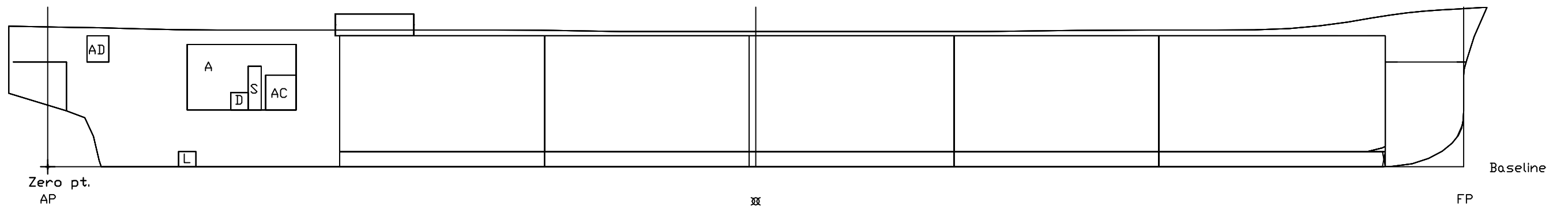

Tanques:
 A: TANQUES DE ALMACÉN
 D: TANQUES DE USO DIARIO
 S: TANQUES DE SEDIMENTACIÓN
 AC: TANQUES DE ACEITE
 AD: TANQUES DE AGUA DULCE
 L: TANQUE DE Lodos



UNIVERSIDADE DA CORUÑA

ESCUELA POLITÉCNICA SUPERIOR

TRABAJO DE FIN DE GRADO

PROYECTO:

PETROLERO VLCC DE 300.000 TPM

PLANO:

PLANO LONGITUDINAL DE TANQUES

AUTOR:

PEDRO LEMOS GONZÁLEZ

FECHA:

JUNIO 2022

ESCALA:

1:1000

HOJA:

2

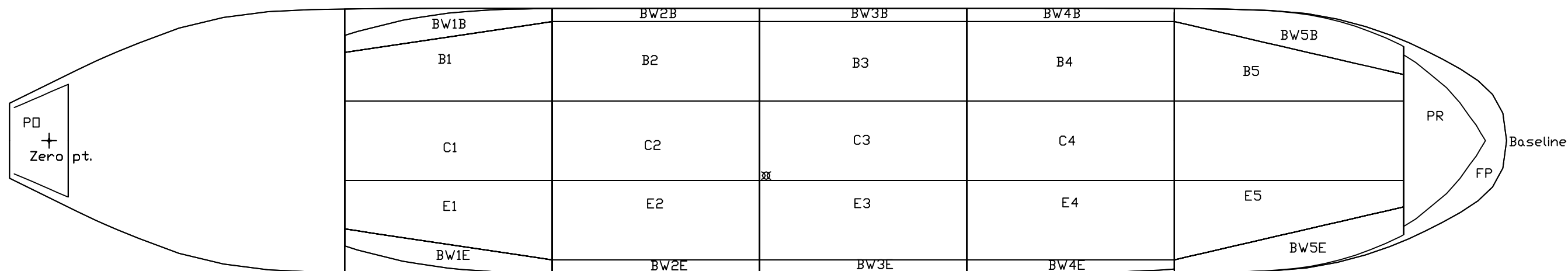

Tanques:

- Bx: TANQUES DE CARGA DE BABOR
- Cx: TANQUES DE CARGA CENTRALES
- Ex: TANQUES DE CARGA DE ESTRIBOR
- BWxB: TANQUES DE LASTRE DE BABOR
- BWxE: TANQUES DE LASTRE DE ESTRIBOR.
- PD: PIQUE DE POPA
- PR: PIQUE DE PROA



UNIVERSIDADE DA CORUÑA

ESCUELA POLITÉCNICA SUPERIOR

TRABAJO DE FIN DE GRADO

PROYECTO:

PETROLERO VLCC DE 300.000 TPM

PLANO:

DISPOSICIÓN DE TANQUES DE CARGA Y LASTRE

AUTOR:

PEDRO LEMOS GONZÁLEZ

FECHA:

JUNIO 2022

ESCALA:

1:1000

HOJA:

3

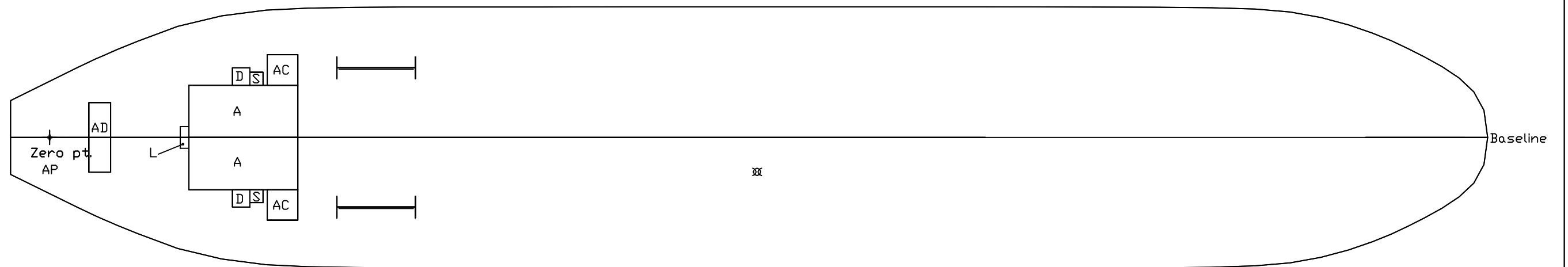

Tanques:
 A: TANQUES DE ALMACÉN
 D: TANQUES DE USO DIARIO
 S: TANQUES DE SEDIMENTACIÓN
 AC: TANQUES DE ACEITE
 AD: TANQUES DE AGUA DULCE
 L: TANQUE DE LODOS

 UNIVERSIDADE DA CORUÑA		ESCUELA POLITÉCNICA SUPERIOR TRABAJO DE FIN DE GRADO	
PROYECTO: PETROLERO VLCC DE 300.000 TPM			
PLANO: DISPOSICIÓN DE TANQUES DE CONSUMOS			
AUTOR: PEDRO LEMOS GONZÁLEZ	FECHA: JUNIO 2022	ESCALA: 1:1000	HOJA: 4